

WHEN DISASSEMBLING ALUMINUM EXTRUSION, TIGHTEN ALL SETSCREWS AND LOCKS TO PREVENT LOSS DURING SHIPPING

visionary™ IDESIGNS

Using Your Setup Instructions

The Visionary Designs Setup Instructions are created specifically for your configuration. They are laid out sequentially, including an exploded view of the entire display, and then a logical series of detailed steps to assemble the main structure and components. We encourage you to study the instructions **before** attempting to assemble your exhibit.

Each page reminds you to tighten the setscrews after disassembling your exhibit to prevent loss of the locks and setscrews (see below in RED). This is **VERY IMPORTANT**.

Cleaning and Packing Your Display

- 1) Use care when cleaning aluminum extrusion or acrylic inserts. Use only non-abrasive cleaners.
- 2) When cleaning laminate inserts or countertops, use mild cleansers and a soft material such as cotton.
- 3) Keep all display components away from extreme heat and long exposure to sunlight to avoid warping and fading.
- 4) Retain all packing material. It will make re-packing much easier and will reduce the likelihood of shipping damage.



The Tool

Most Visionary Designs exhibits can be assembled with the supplied Hex Key Tool. Occasionally, a flat head screwdriver may be required.



Detail A

Typical Connection

Most horizontal extrusion connections have a patented expandable lock. This lock inserts into the groove of an opposing extrusion. Tightening the lock with the Hex Key Tool expands the lock and creates a strong positive connection.



Typical Connection (cont'd)

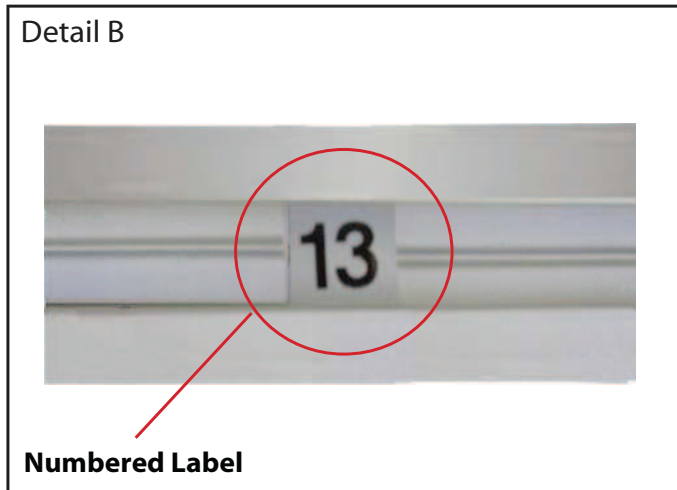

Detail B

Numbered Label

Each extrusion contains a numbered label which corresponds with setup instructions. The label is located within a groove of the extrusion (when possible). With Visionary Designs the labels contain Black numbers unless otherwise specified.



Detail C

Horizontal Inline Connection (remove only one setscrew)

Remove only (1) setscrew when disassembling. Replace setscrew in extrusion after assembling it. Before packing, replace setscrew in extrusion to avoid losing it.

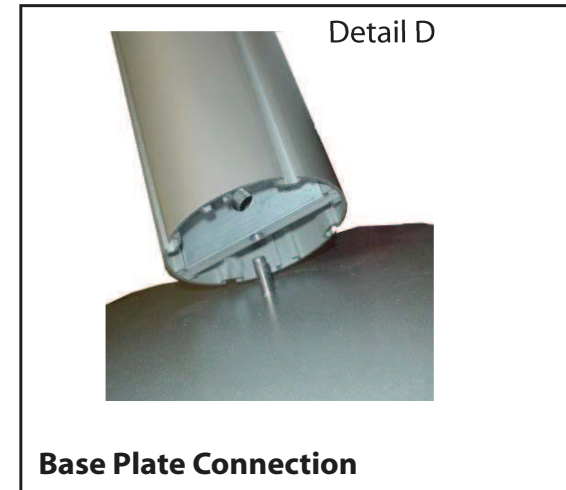

Detail D

Base Plate Connection

Attach base plate to round or square vertical extrusion using the bolt provided. Be careful not to strip the threads.

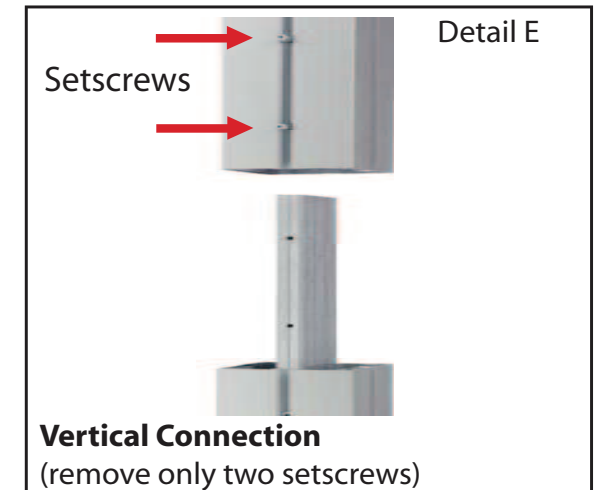

Detail E

Vertical Connection
(remove only two setscrews)

When vertical extrusions are packed in portable cases rather than crates or tubs, they must be broken down into smaller sections which then require assembly.

Remove only (2) setscrews when disassembling. Replace setscrews in extrusion after assembling it. Before packing, replace setscrews in extrusion to avoid losing them.

WHEN DISASSEMBLING ALUMINUM EXTRUSION, TIGHTEN ALL SETSCREWS AND LOCKS TO PREVENT LOSS DURING SHIPPING

866.652.2100

Item	Qty.	Description
1	4	36" h Round Vertical Extrusion w/ Door Stopper
2	4	36" h Round Vertical Extrusion w/ Hinges
3	4	36" h Round Vertical Extrusion w/ Door Stopper
4	4	36" h Round Vertical Extrusion w/ Hinges
5	16	15" w Horizontal Extrusion
6	8	47.54" Formed Horizontal Extrusion
7	8	57.94" Formed Horizontal Extrusion

Steps:

- 1) Connect horizontal extrusions 5,6 and 7 between round vertical extrusions 1,2,3 and 4.
- 2) Place inserts and attach doors as shown
- 3) Attach light reflector to back of insert as shown.
- 4) Connect horizontal extrusions 5,6 and 7 between round vertical extrusions 1,2,3 and 4 and atop inserts and doors.

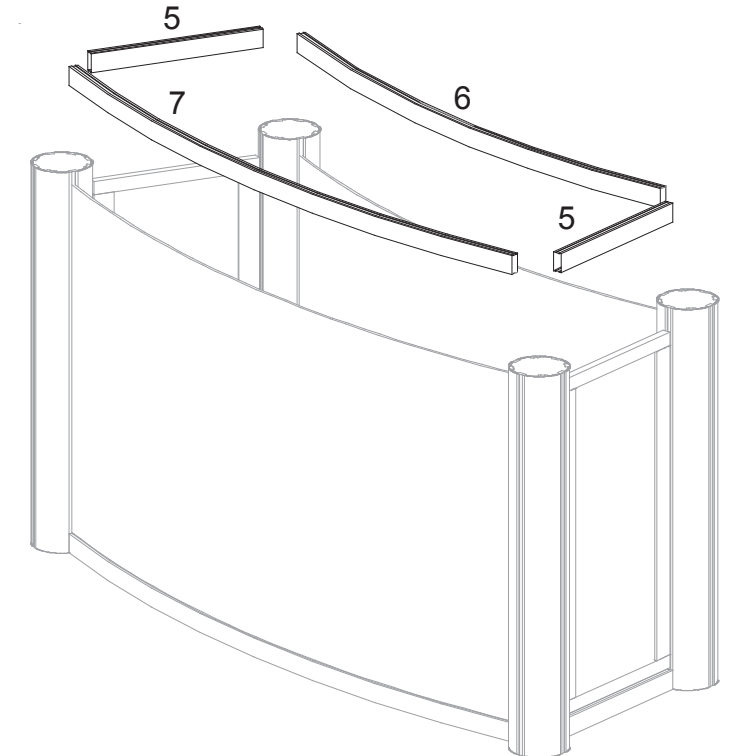
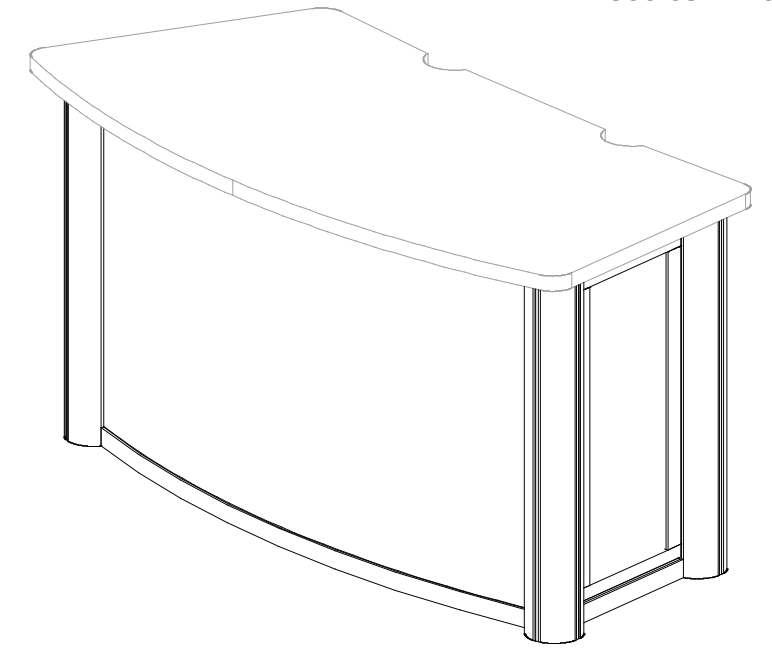
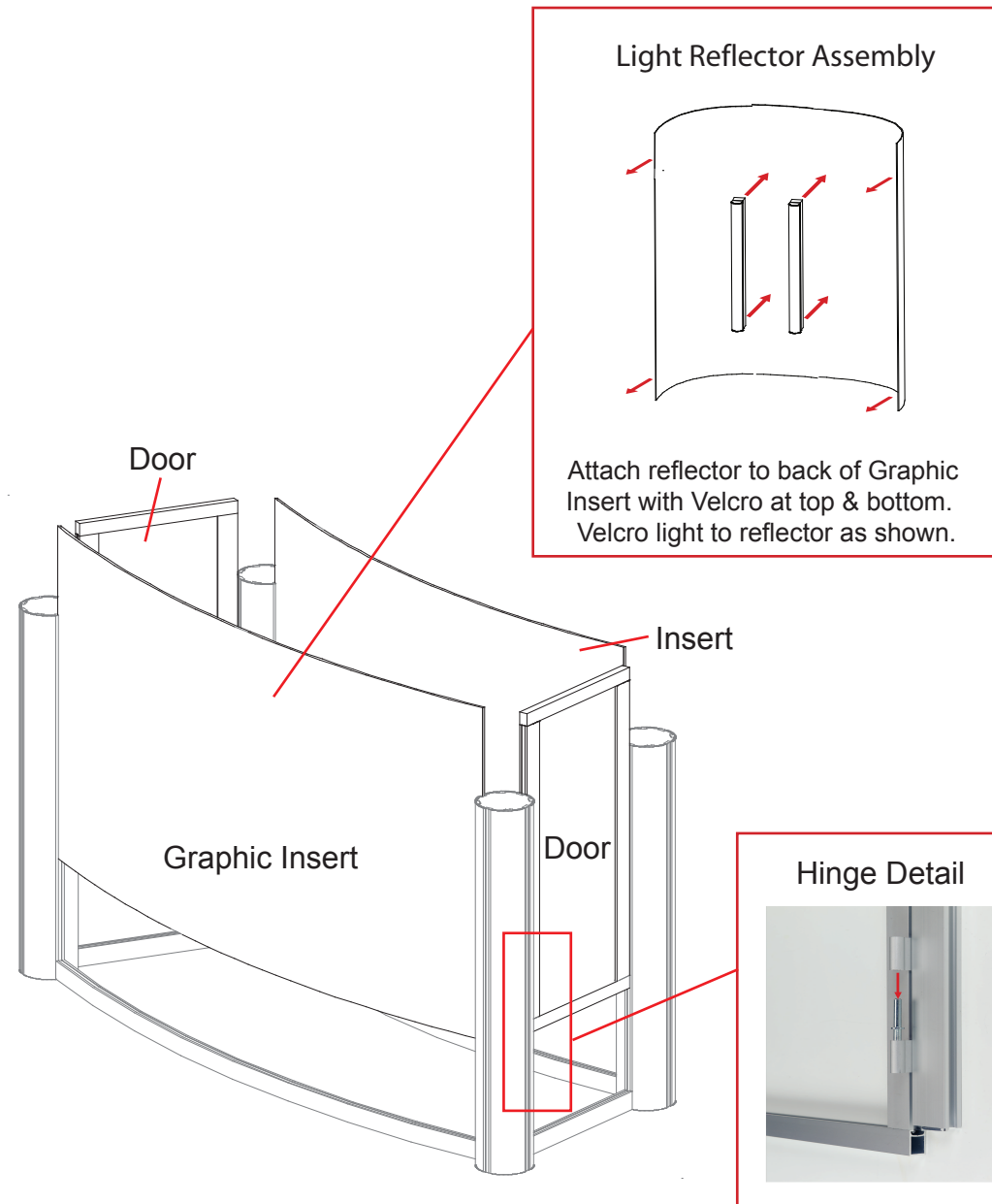
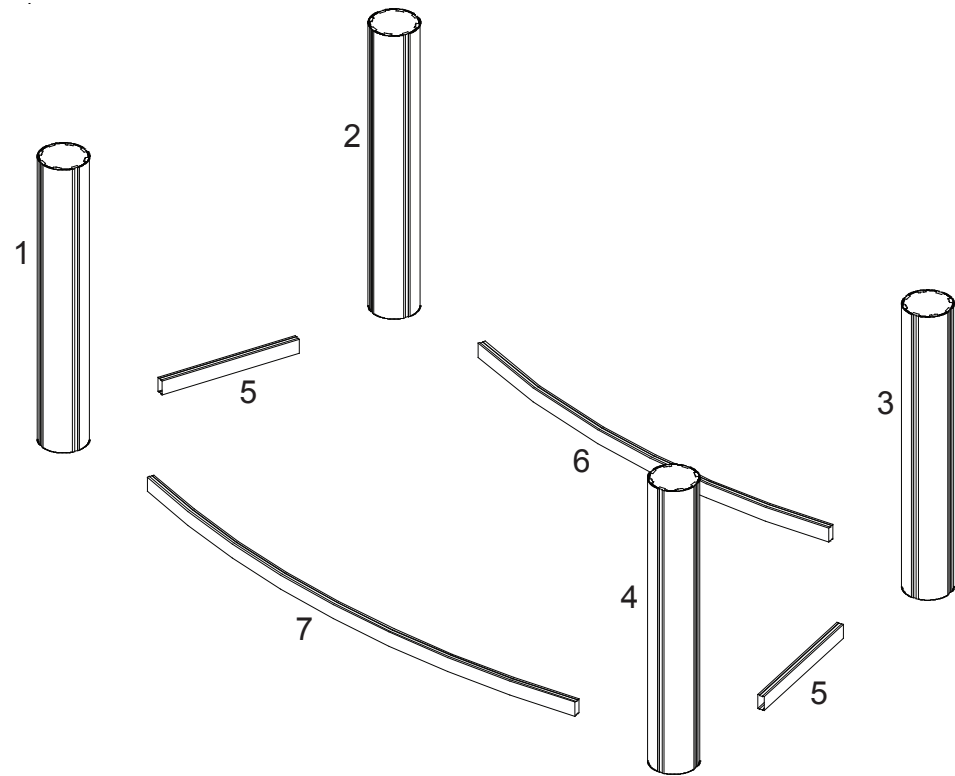

WHEN DISASSEMBLING ALUMINUM EXTRUSION, TIGHTEN ALL SETSCREWS AND LOCKS TO PREVENT LOSS DURING SHIPPING

866.652.2100

Steps (cont'd):

- 5) Velcro supports to vertical extrusions, as shown.
- 5) Set internal shelf atop supports, and place counter top on assembled workstation.
- 6) Repeat steps for additional workstations.

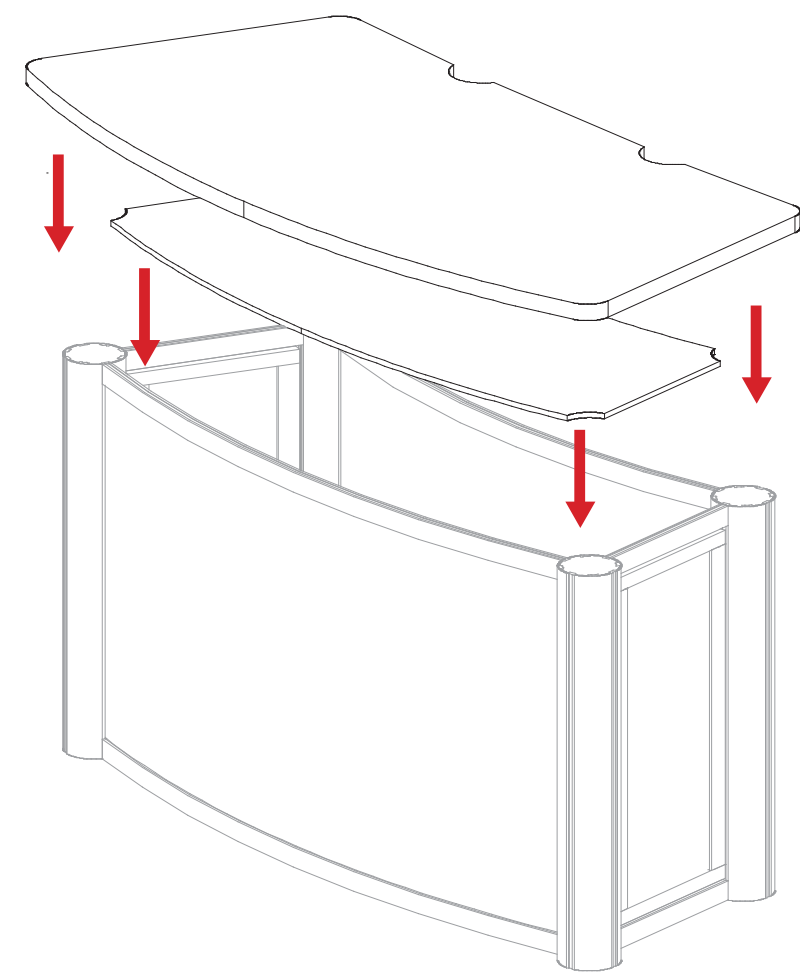
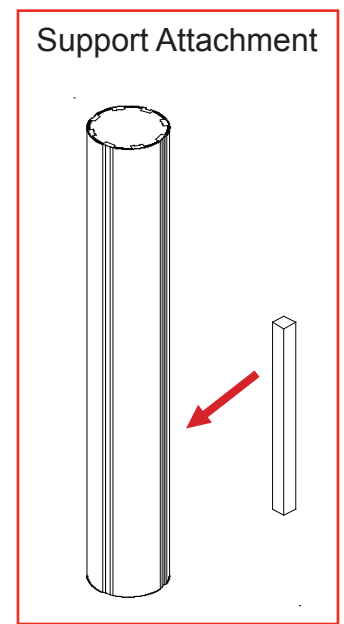
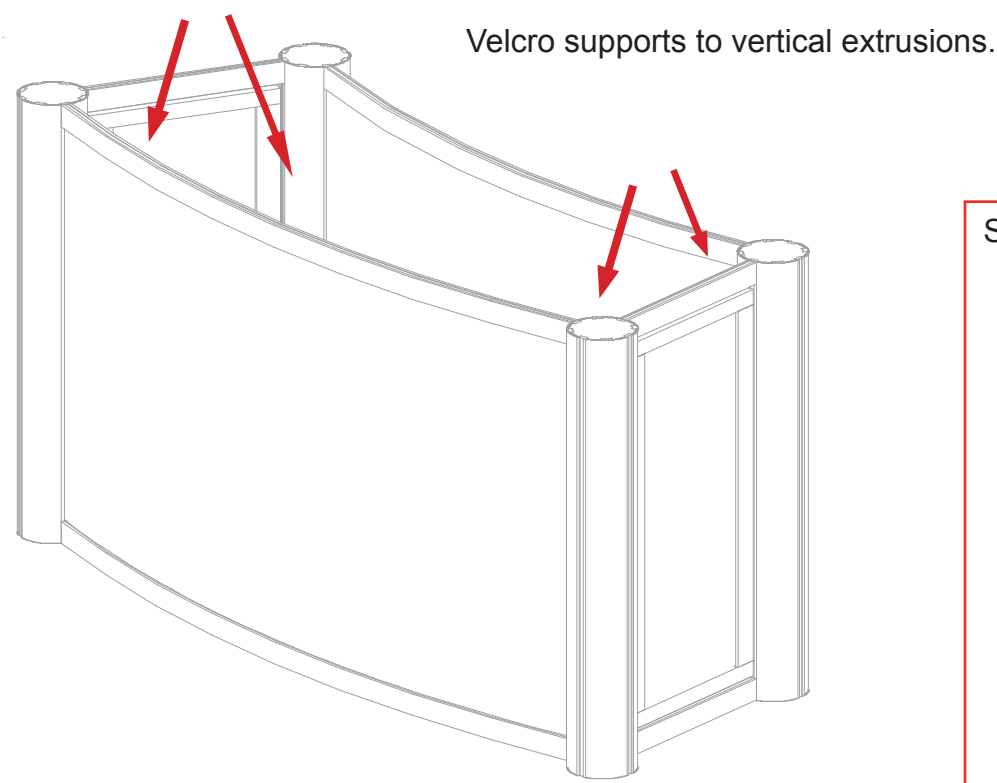
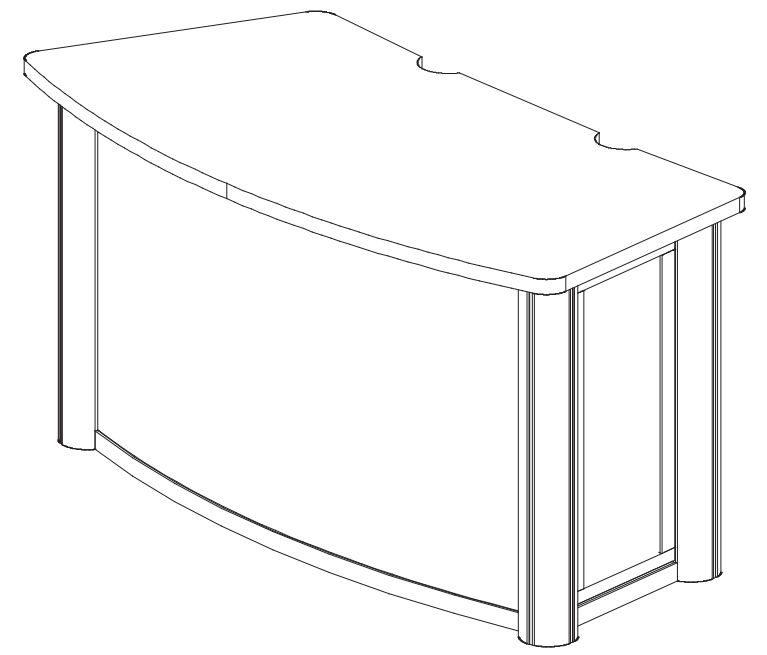

Set internal shelf atop supports, and place counter top on assembled workstation.

WHEN DISASSEMBLING ALUMINUM EXTRUSION, TIGHTEN ALL SETSCREWS AND LOCKS TO PREVENT LOSS DURING SHIPPING

866.652.2100

Item	Qty.	Description
8	16	96" h Lower Round Vertical Extrusion
9	48	19" w Horizontal Extrusion

Steps:

- 1) Connect horizontal extrusions 9 between 96" round vertical extrusions 8.
- 2) Place inserts as shown.
- 3) Connect horizontal extrusions 9 between round vertical extrusions 8 and atop inserts.

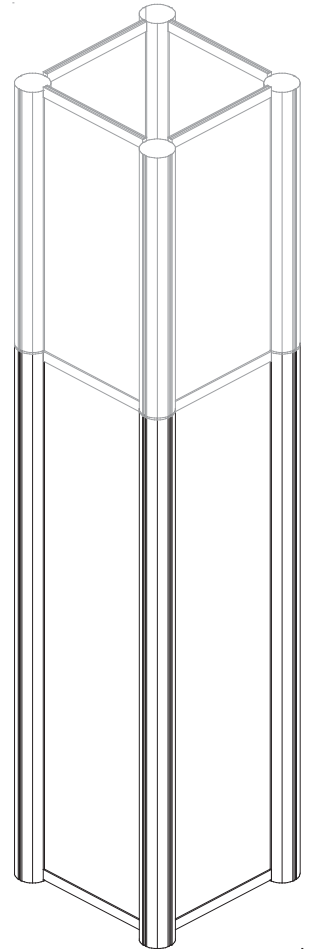
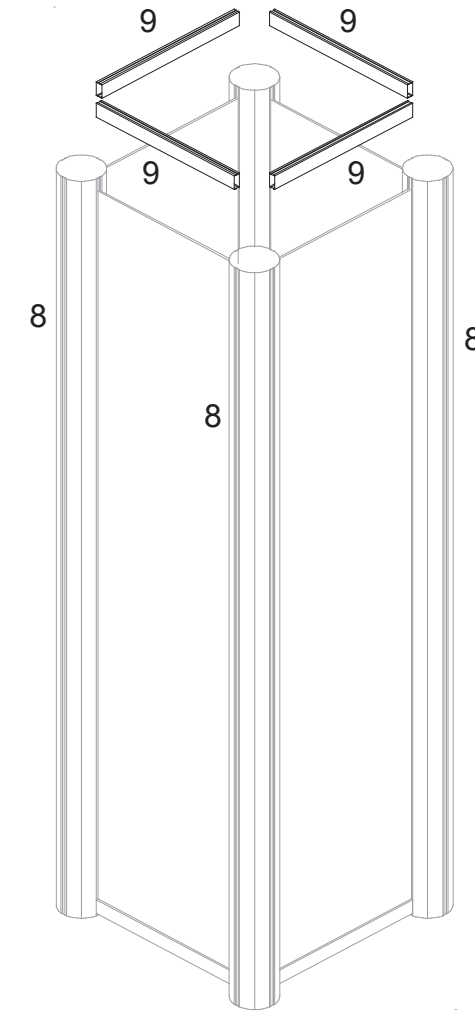
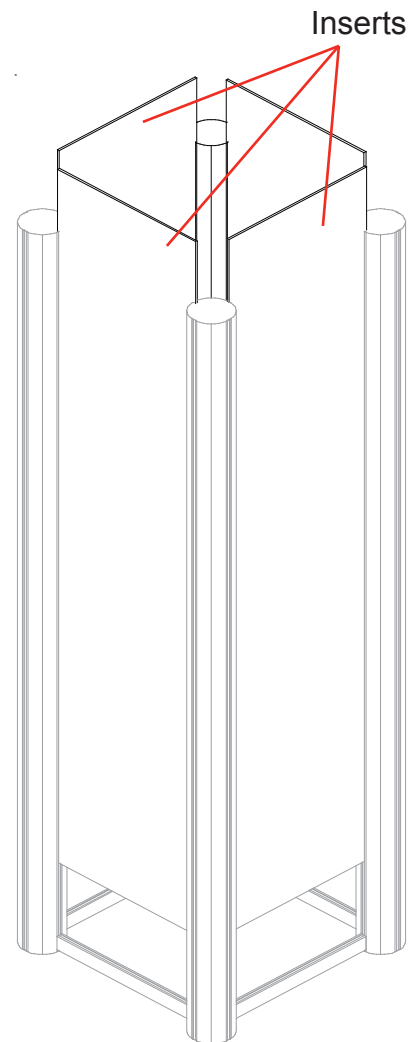
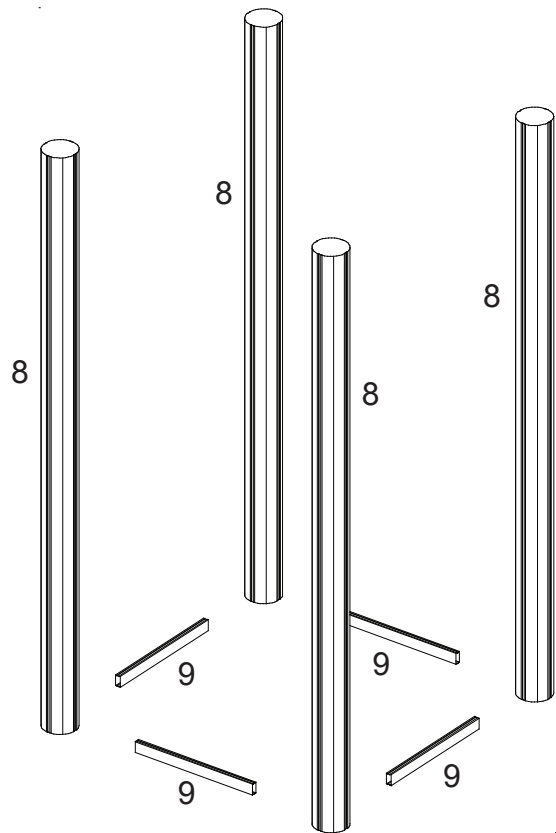

WHEN DISASSEMBLING ALUMINUM EXTRUSION, TIGHTEN ALL SETSCREWS AND LOCKS TO PREVENT LOSS DURING SHIPPING

Item	Qty.	Description
9	48	48" h Lower Round Vertical Extrusion
10	16	19" w Horizontal Extrusion

Steps (cont'd):

- 4) Place 48" round vertical extrusions 10 atop 96" round vertical extrusions 8.
- 5) Place inserts as shown.
- 6) Connect horizontal extrusions 9 between round vertical extrusions 10 and atop inserts.
- 7) Repeat steps for additional towers.

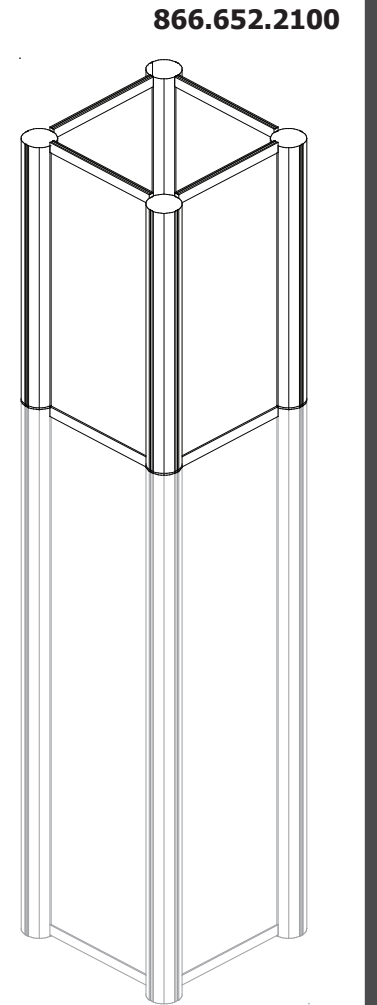
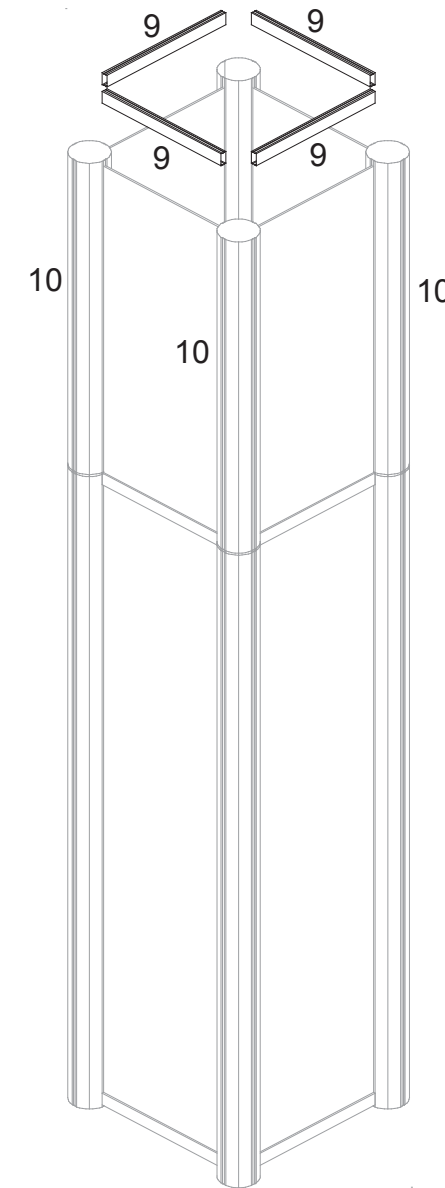
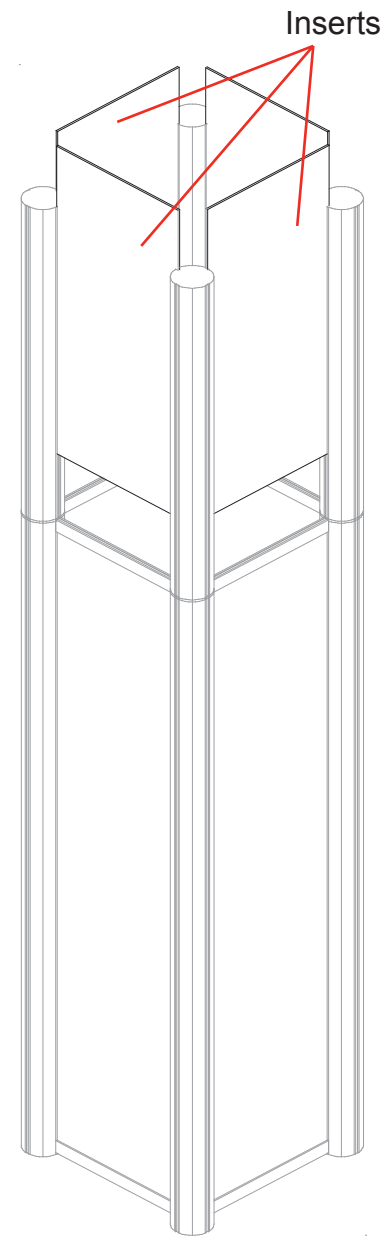
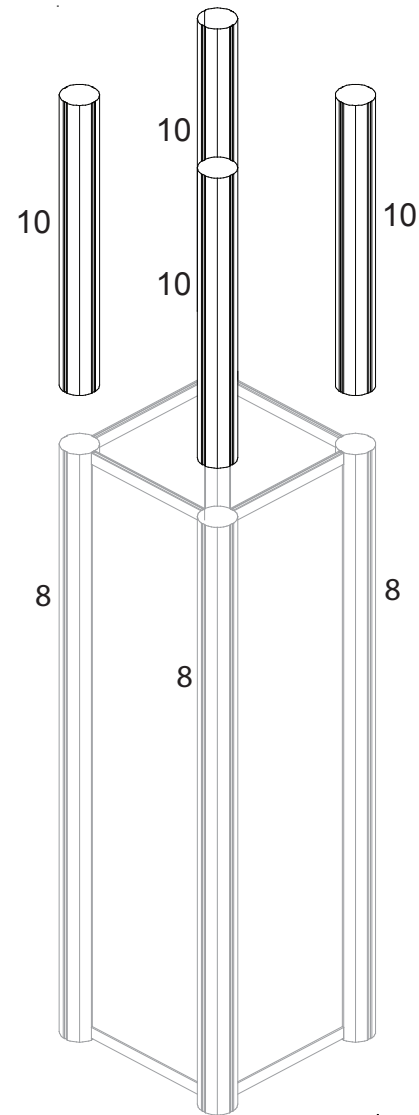

WHEN DISASSEMBLING ALUMINUM EXTRUSION, TIGHTEN ALL SETSCREWS AND LOCKS TO PREVENT LOSS DURING SHIPPING

866.652.2100

Item	Qty.	Description
11	4	36" h Left Vertical Extrusion
12	4	36" h Right Vertical Extrusion
13a/13b	4/4	Formed Horizontal Extrusion
14a/14a	4/4	Formed Horizontal Extrusion

Steps :

- 1) Connect formed horizontal extrusions 13a to 13b and 14a to 14b together.
- 2) Connect assembled formed horizontal extrusions between vertical extrusions 11 and 12.
- 3) Attached assembled rings between assembled towers.
- 4) Repeat steps for additional decorative rings.

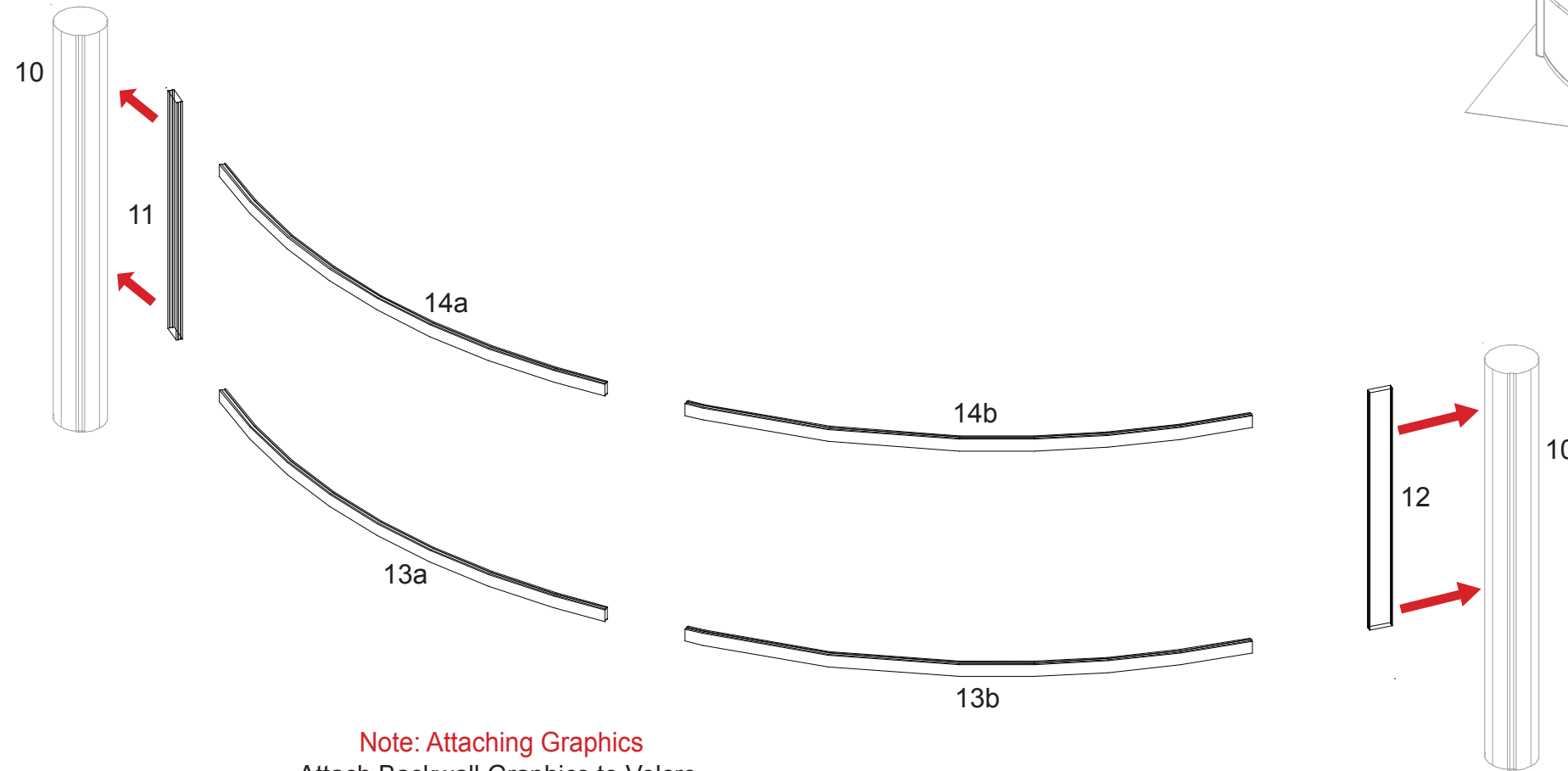

Note: Attaching Graphics
 Attach Backwall Graphics to Velcro
 by Applying to Back of Extrusions.

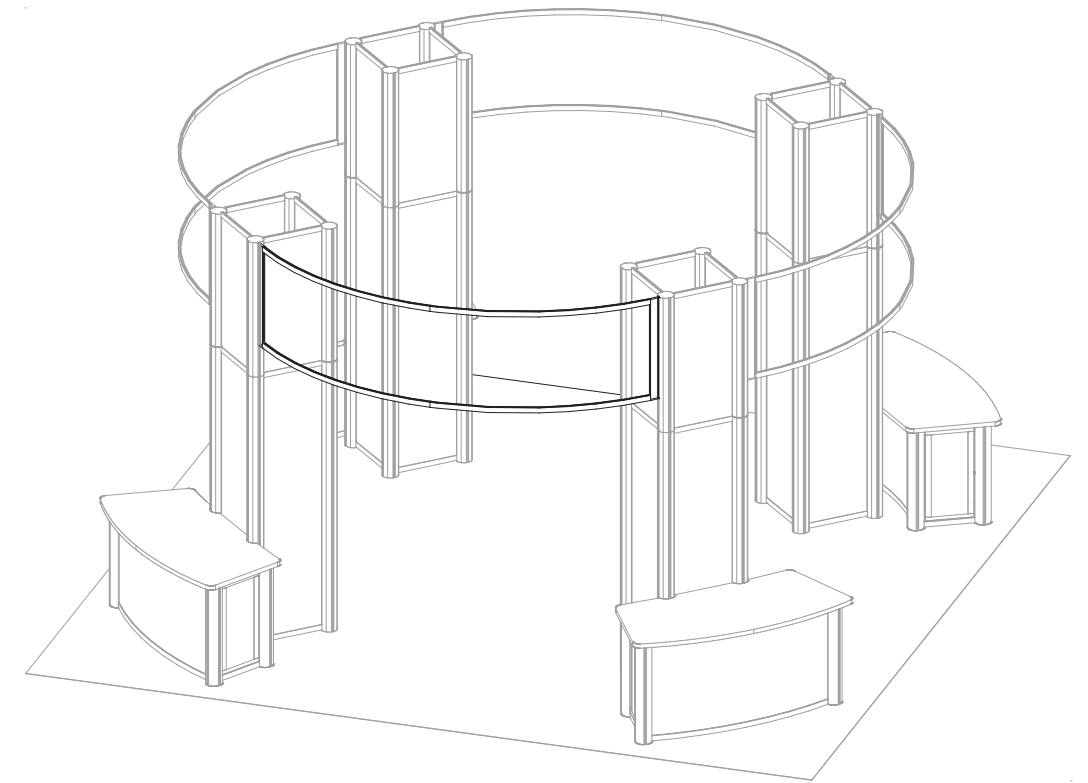

WHEN DISASSEMBLING ALUMINUM EXTRUSION, TIGHTEN ALL SETSCREWS AND LOCKS TO PREVENT LOSS DURING SHIPPING