

WHEN DISASSEMBLING ALUMINUM EXTRUSION, TIGHTEN ALL SETSCREWS AND LOCKS TO PREVENT LOSS DURING SHIPPING

# visionary™ DESIGNS

## Using Your Setup Instructions

The Visionary Designs Setup Instructions are created specifically for your configuration. They are laid out sequentially, including an exploded view of the entire display, and then a logical series of detailed steps to assemble the main structure and components. We encourage you to study the instructions **before** attempting to assemble your exhibit.

Each page reminds you to tighten the setscrews after disassembling your exhibit to prevent loss of the locks and setscrews (see below in RED). This is **VERY IMPORTANT**.

## Cleaning and Packing Your Display

- 1) Use care when cleaning aluminum extrusion or acrylic inserts. Use only non-abrasive cleaners.
- 2) When cleaning laminate inserts or countertops, use mild cleansers and a soft material such as cotton.
- 3) Keep all display components away from extreme heat and long exposure to sunlight to avoid warping and fading.
- 4) Retain all packing material. It will make re-packing much easier and will reduce the likelihood of shipping damage.



**The Tool**

Most Visionary Designs exhibits can be assembled with the supplied Hex Key Tool. Occasionally, a flat head screwdriver may be required.

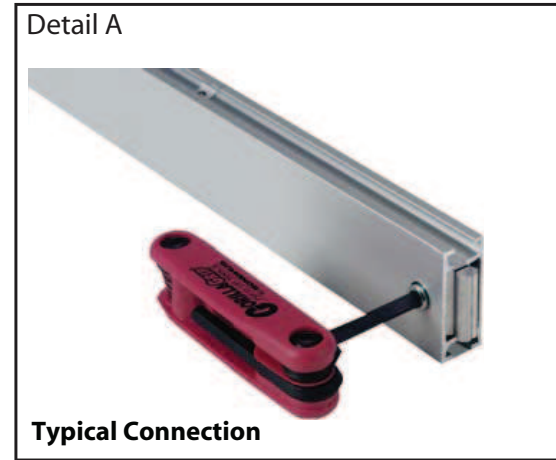

Detail A

**Typical Connection**

Most horizontal extrusion connections have a patented expandable lock. This lock inserts into the groove of an opposing extrusion. Tightening the lock with the Hex Key Tool expands the lock and creates a strong positive connection.



**Typical Connection (cont'd)**

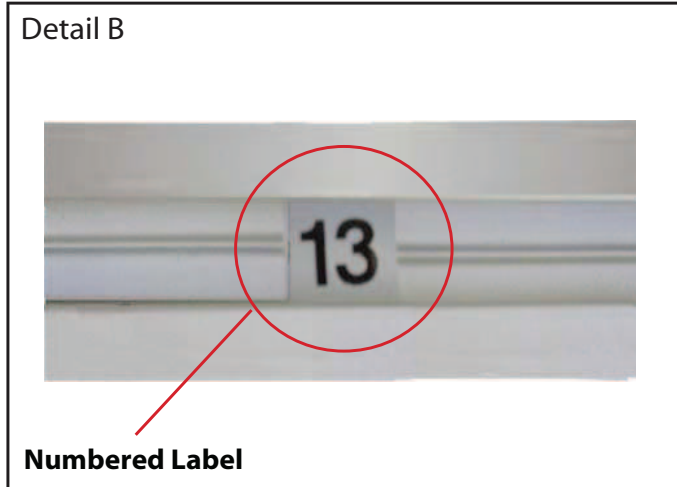

Detail B

**Numbered Label**

Each extrusion contains a numbered label which corresponds with setup instructions. The label is located within a groove of the extrusion (when possible). With Visionary Designs the labels contain Black numbers unless otherwise specified.



Detail C

**Horizontal Inline Connection** (remove only one setscrew)

Remove only (1) setscrew when disassembling. Replace setscrew in extrusion after assembling it. Before packing, replace setscrew in extrusion to avoid losing it.

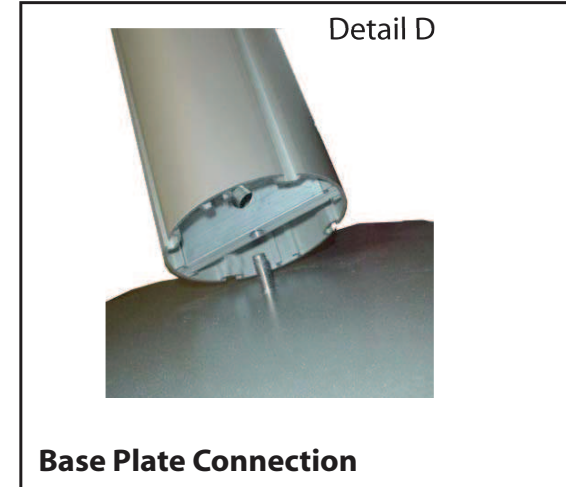

Detail D

**Base Plate Connection**

Attach base plate to round or square vertical extrusion using the bolt provided. Be careful not to strip the threads.

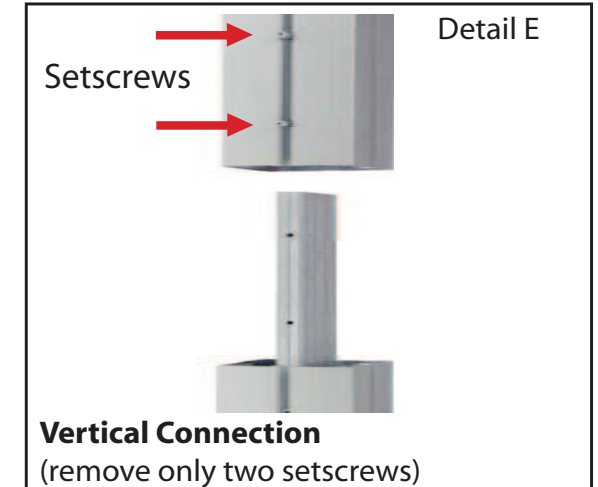

Detail E

**Vertical Connection**  
(remove only two setscrews)

When vertical extrusions are packed in portable cases rather than crates or tubs, they must be broken down into smaller sections which then require assembly.

Remove only (2) setscrews when disassembling. Replace setscrews in extrusion after assembling it. Before packing, replace setscrews in extrusion to avoid losing them.

**WHEN DISASSEMBLING ALUMINUM EXTRUSION, TIGHTEN ALL SETSCREWS AND LOCKS TO PREVENT LOSS DURING SHIPPING**

866.652.2100

Part Number	Qty for Step	Description
1	5	96"h Vertical extrusion
1A	2	96"h Vertical extrusion
2	2	96"h Vertical extrusion
3	6	9.5"w Horizontal Extrusion
4	6	51.5"w Horizontal Extrusion
5	2	47"w Horizontal Extrusion
6	4	16.041"w Horizontal Extrusion

**Steps**

- 1) Connect horizontal extrusions [3] between vertical extrusions [1 and 1A] placing inserts as indicated.
- 2) Connect horizontal extrusions [4] between vertical extrusions [1A and 2] placing inserts as indicated.
- 3) Connect horizontal extrusions [5] between vertical extrusions [2] placing inserts as indicated.
- 4) Connect horizontal extrusions [4] between vertical extrusions [1A and 1] placing inserts as indicated.
- 5) Connect horizontal extrusions [6] between vertical extrusions [1A and 1] placing inserts as indicated.

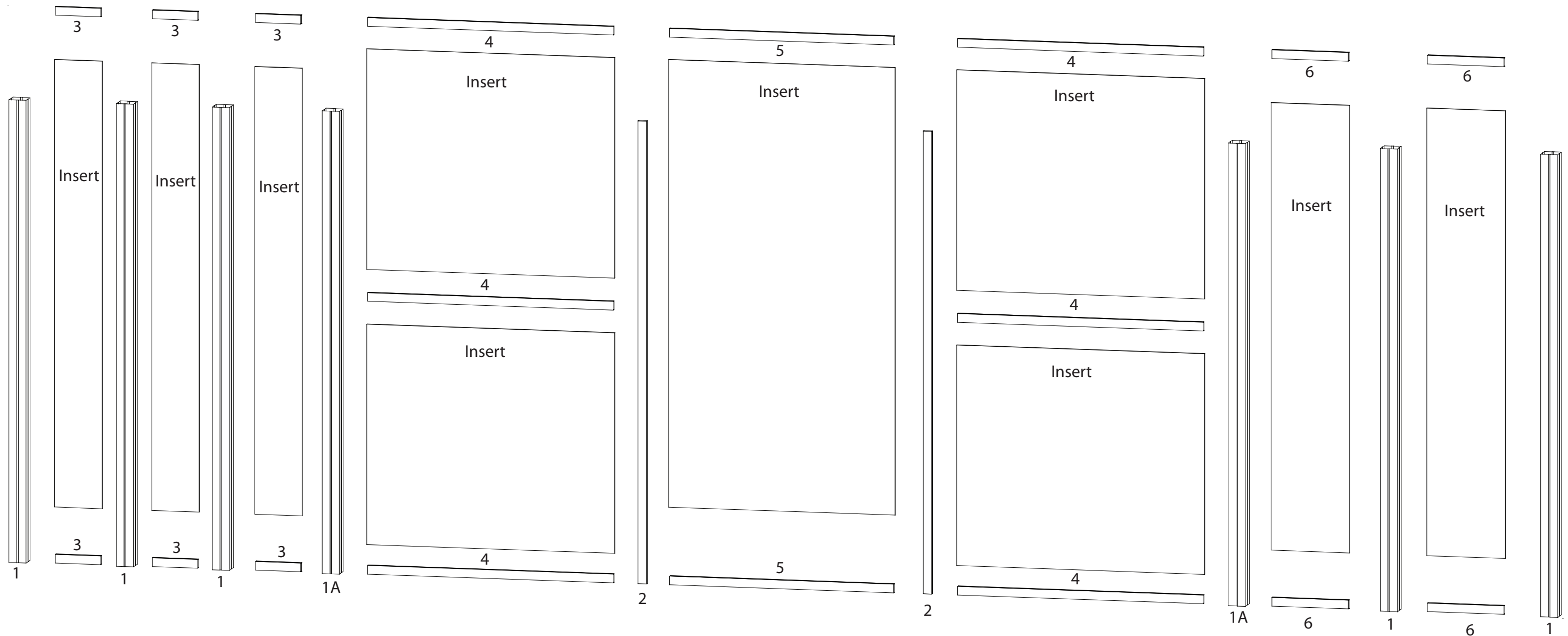

**WHEN DISASSEMBLING ALUMINUM EXTRUSION, TIGHTEN ALL SETSCREWS AND LOCKS TO PREVENT LOSS DURING SHIPPING**

Part Number	Qty for Step	Description	Steps
1A	2	96" h Vertical extrusion	1) Connect horizontal extrusions [7] between vertical extrusions [1A and 1A from previous page] placing inserts as indicated.
2	2	96" h Vertical extrusion	2) Connect horizontal extrusions [8] between vertical extrusions [1A and 2].
7	4	17" w Horizontal Extrusion	3) Connect horizontal extrusions [9] between vertical extrusions [2].
8	4	51.5" w Horizontal Extrusion	4) Connect horizontal extrusions [8] between vertical extrusions [2 and 1A].
9	3	47" w Horizontal Extrusion	

**Note: Attaching Graphics**  
 Attach Backwall Graphics to Velcro on the Back Top of the Upper Horizontals and Back Bottom of the Lower Horizontals

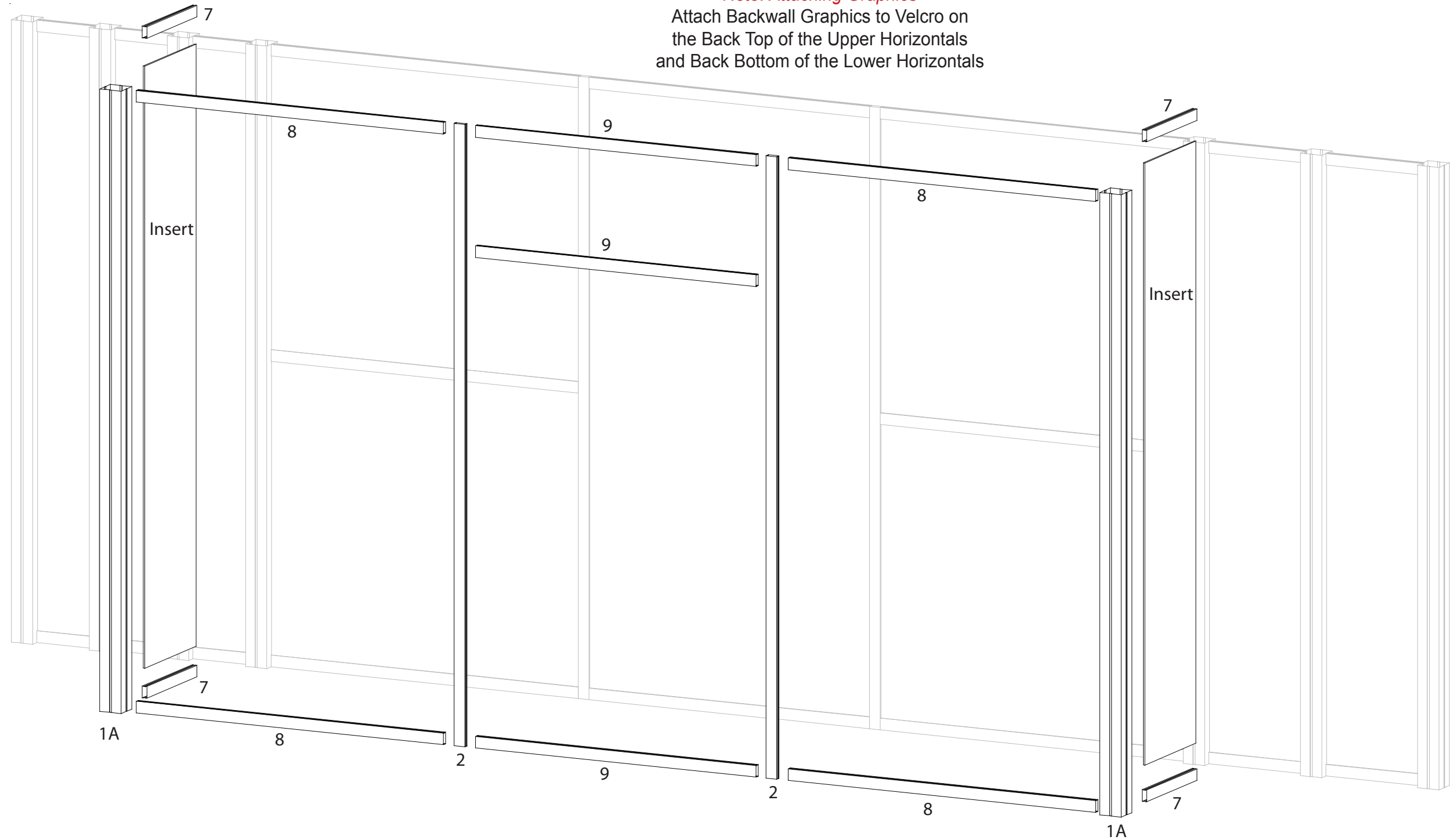

**WHEN DISASSEMBLING ALUMINUM EXTRUSION, TIGHTEN ALL SETSCREWS AND LOCKS TO PREVENT LOSS DURING SHIPPING**

866.652.2100

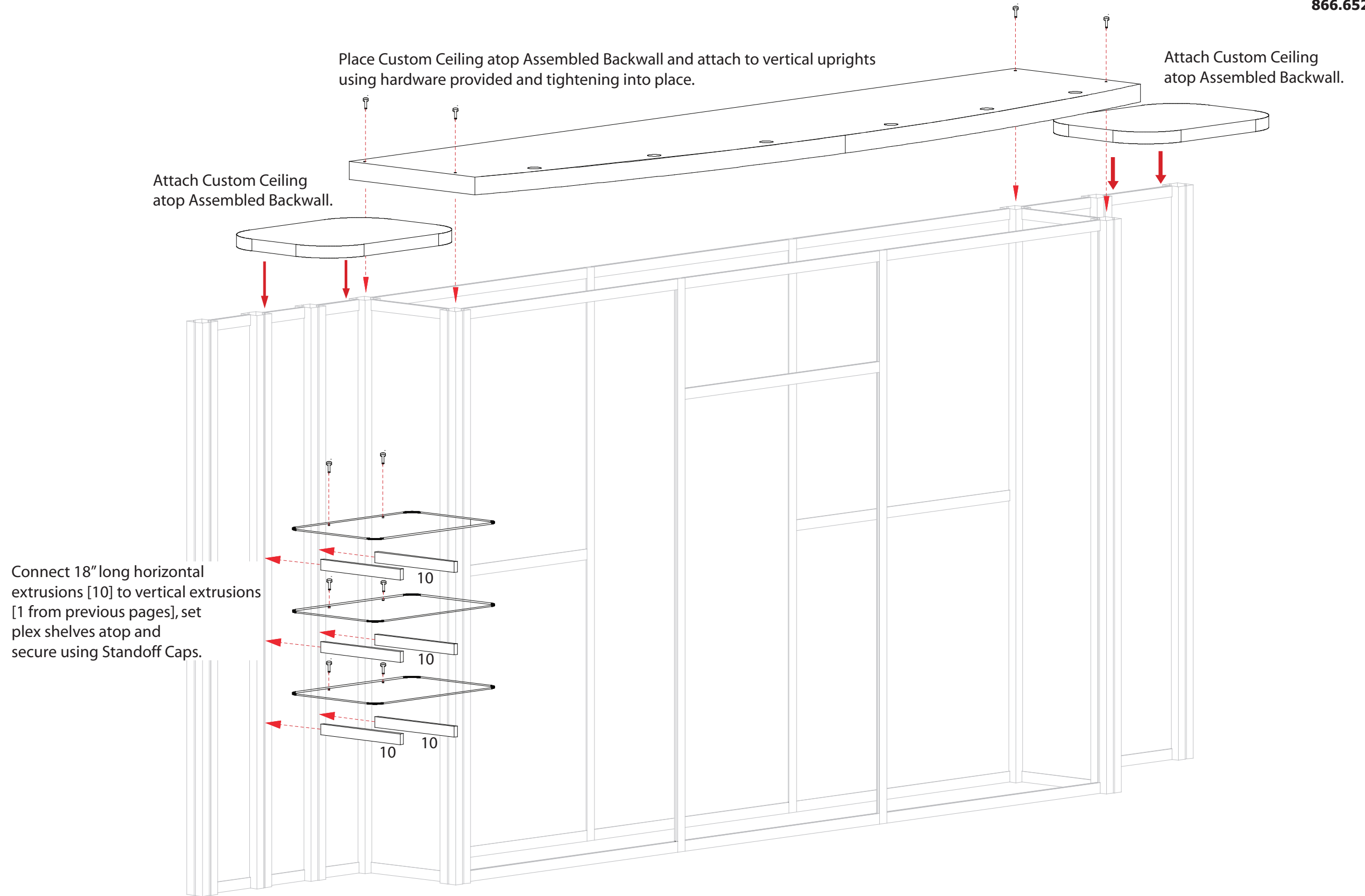

**WHEN DISASSEMBLING ALUMINUM EXTRUSION, TIGHTEN ALL SETSCREWS AND LOCKS TO PREVENT LOSS DURING SHIPPING**

866.652.2100

Steps:  
Clear pad should go on to the front of the plex graphic between the gripper and the graphic. Attach the gripper to the plex graphic, then attach to the suspended cable

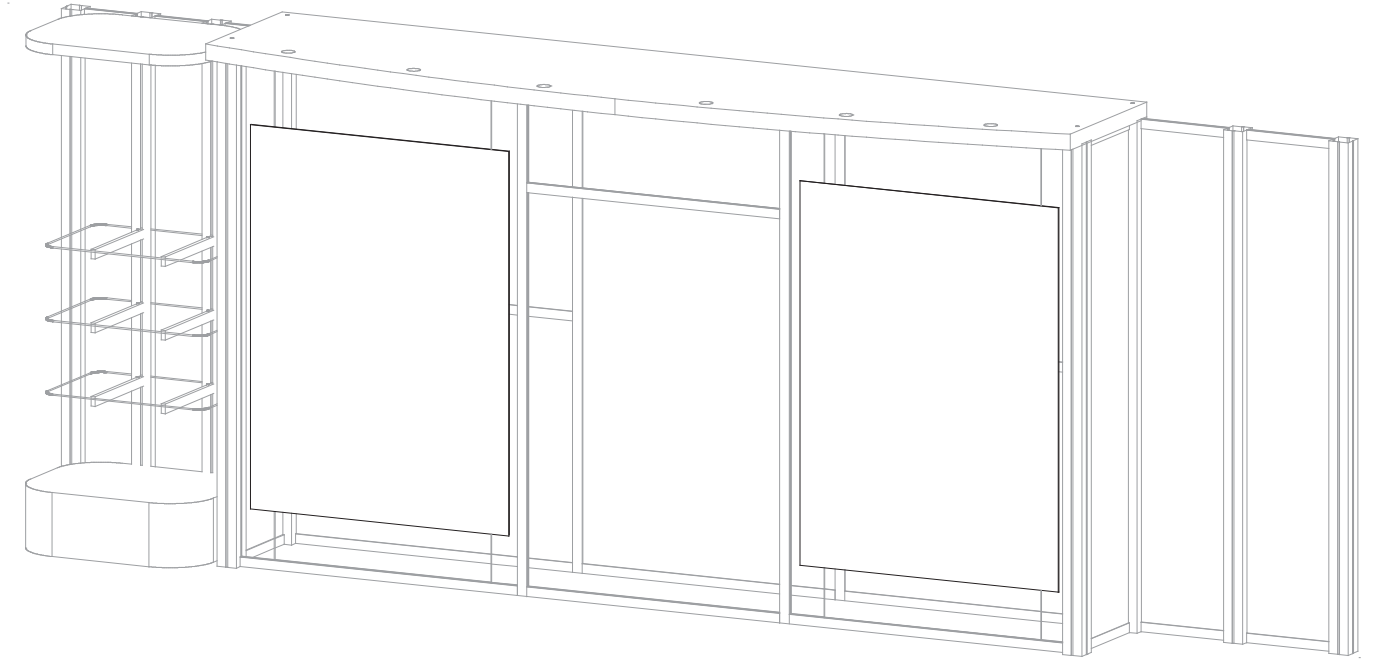
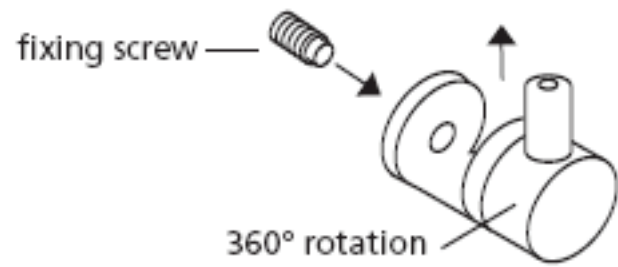
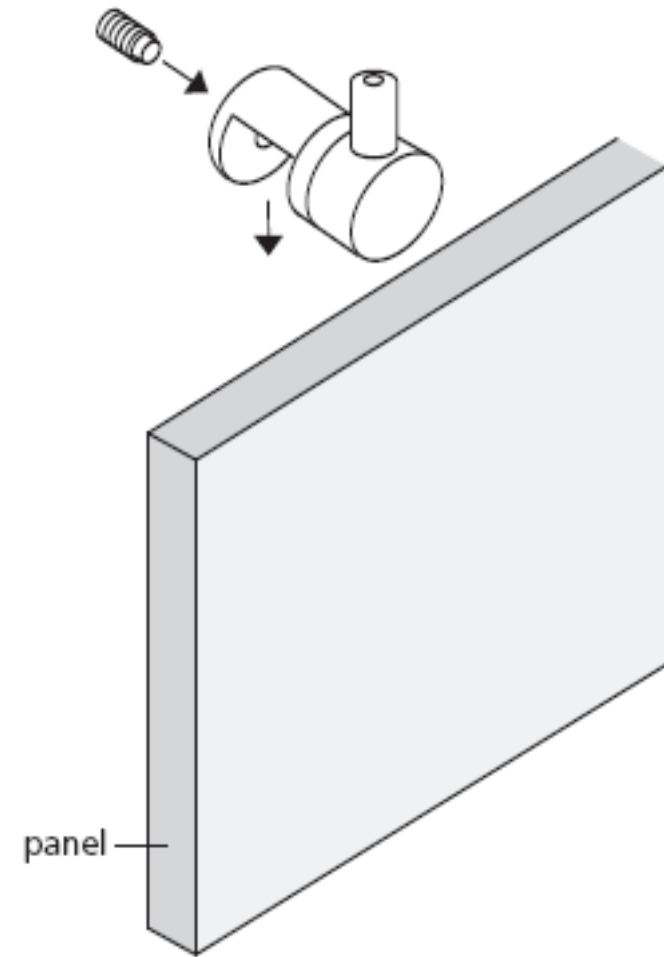

**WHEN DISASSEMBLING ALUMINUM EXTRUSION, TIGHTEN ALL SETSCREWS AND LOCKS TO PREVENT LOSS DURING SHIPPING**

Part Number	Qty for Step	Description
11	2	38" h Tapered Vertical extrusion
12	2	38" h Tapered Vertical extrusion
13	2	22.1985" w Horizontal Extrusion
14	4	22" w Horizontal Extrusion
15	2	33.4293" w Horizontal Extrusion

**Steps**

- 1) Attach Horizontal extrusions [13,14] between Tapered Vertical extrusions [11,12]
- 2) Place Inserts as shown.
- 3) Attach Horizontal extrusions [14,15] between Tapered Vertical extrusions [11,12] and atop Inserts.
- 4) Set Assembled Pedestal on Base plate.
- 5) Attach Stand off barrels to Counter top and secure Plex to stand off barrels using stand off caps
- 6) Place Counter top on Assembled Pedestal.
- 7) Repeat steps for additional Pedestal

866.652.2100

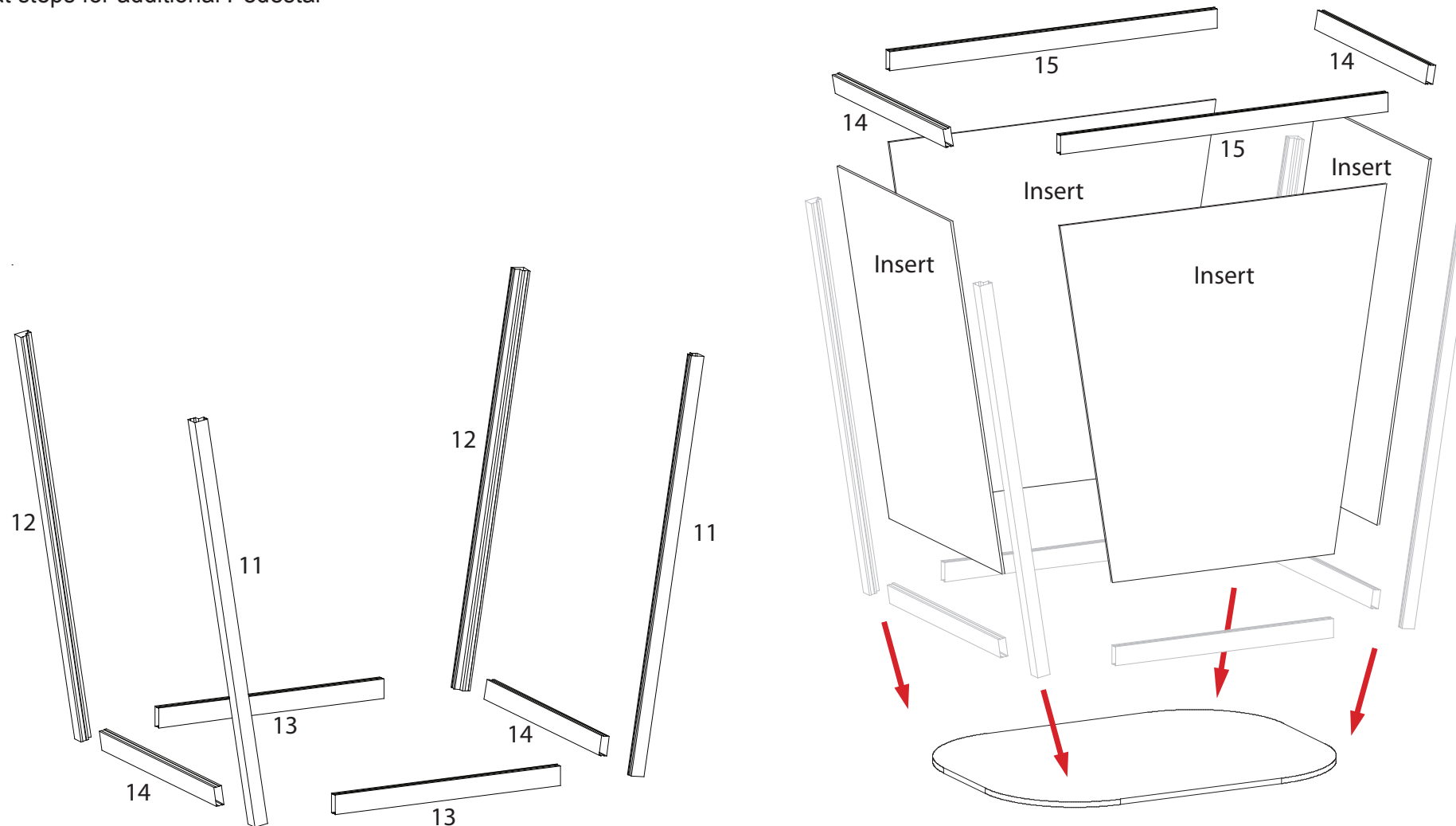
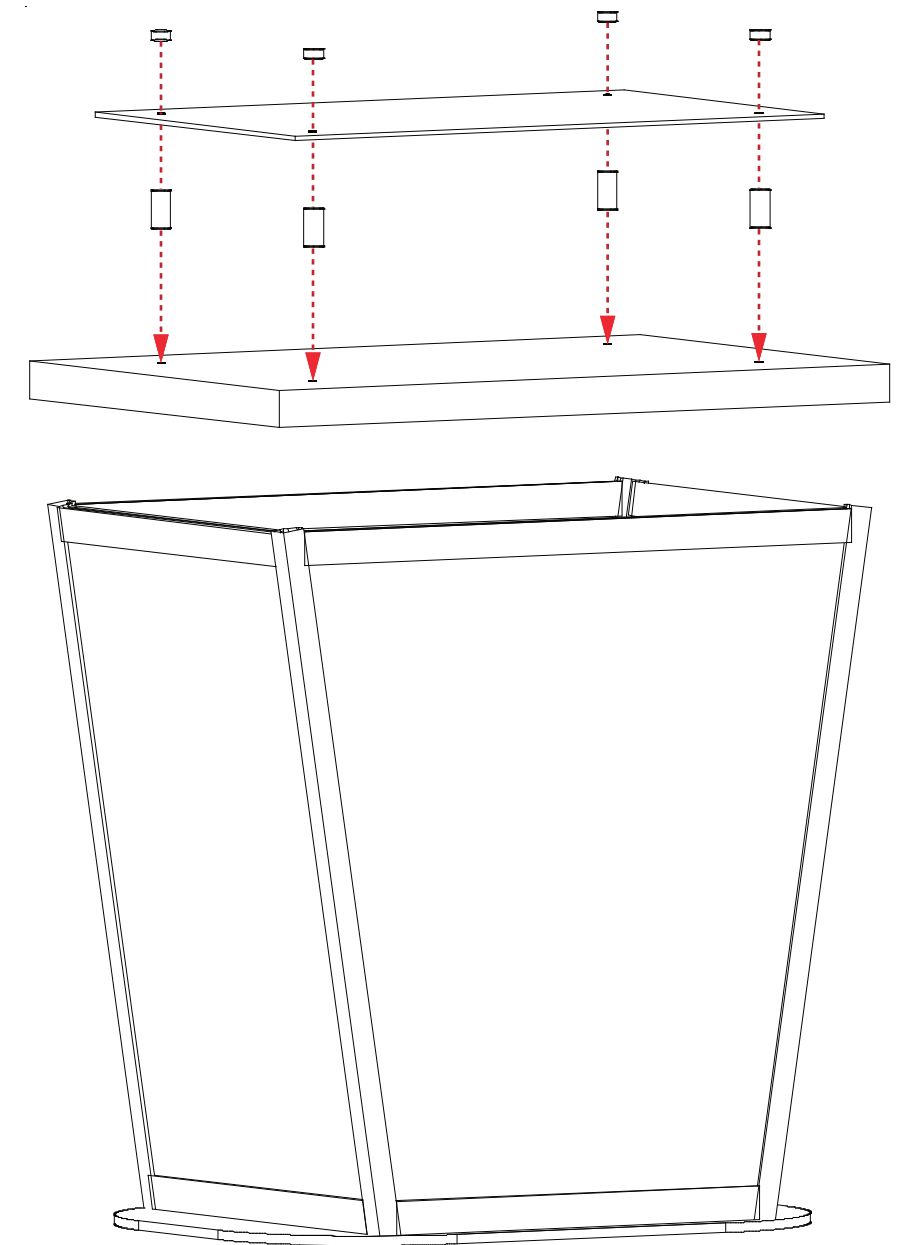
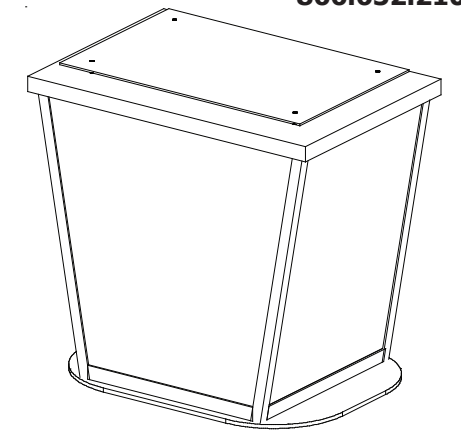

**WHEN DISASSEMBLING ALUMINUM EXTRUSION, TIGHTEN ALL SETSCREWS AND LOCKS TO PREVENT LOSS DURING SHIPPING**