

Plan View

WHEN DISASSEMBLING ALUMINUM EXTRUSION, TIGHTEN ALL SETSCREWS AND LOCKS TO PREVENT LOSS DURING SHIPPING

visionary™ DESIGNS

Using Your Setup Instructions

The Visionary Designs Setup Instructions are created specifically for your configuration. They are laid out sequentially, including an exploded view of the entire display, and then a logical series of detailed steps to assemble the main structure and components. We encourage you to study the instructions **before** attempting to assemble your exhibit.

Each page reminds you to tighten the setscrews after disassembling your exhibit to prevent loss of the locks and setscrews (see below in RED). This is **VERY IMPORTANT**.

Cleaning and Packing Your Display

- 1) Use care when cleaning aluminum extrusion or acrylic inserts. Use only non-abrasive cleaners.
- 2) When cleaning laminate inserts or countertops, use mild cleansers and a soft material such as cotton.
- 3) Keep all display components away from extreme heat and long exposure to sunlight to avoid warping and fading.
- 4) Retain all packing material. It will make re-packing much easier and will reduce the likelihood of shipping damage.



The Tool

Most Visionary Designs exhibits can be assembled with the supplied Hex Key Tool. Occasionally, a flat head screwdriver may be required.

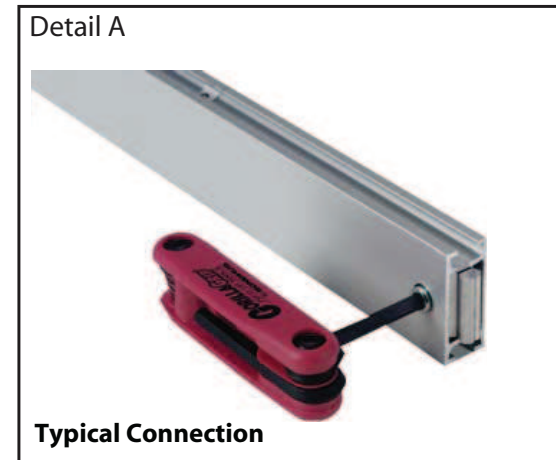

Typical Connection

Most horizontal extrusion connections have a patented expandable lock. This lock inserts into the groove of an opposing extrusion. Tightening the lock with the Hex Key Tool expands the lock and creates a strong positive connection.



Typical Connection (cont'd)

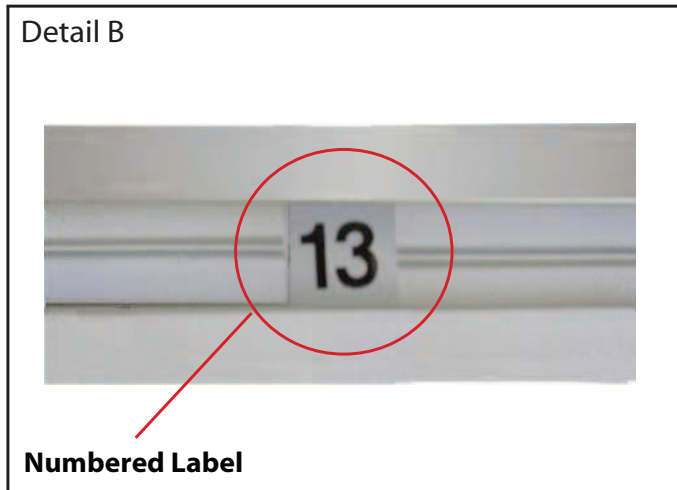

Detail B

Numbered Label

Each extrusion contains a numbered label which corresponds with setup instructions. The label is located within a groove of the extrusion (when possible). With Visionary Designs the labels contain Black numbers unless otherwise specified.



Detail C

Horizontal Inline Connection (remove only one setscrew)

Remove only (1) setscrew when disassembling. Replace setscrew in extrusion after assembling it. Before packing, replace setscrew in extrusion to avoid losing it.

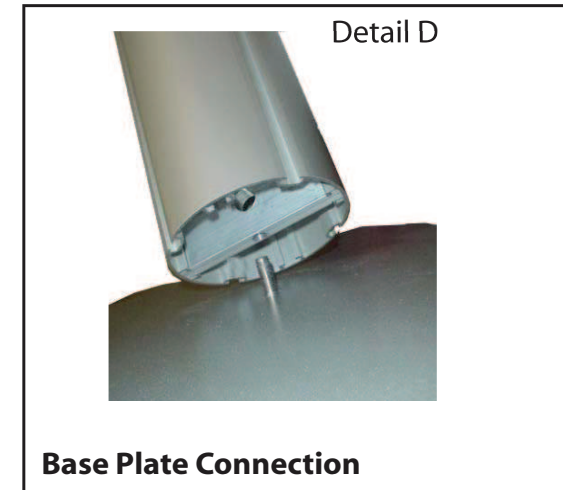

Detail D

Base Plate Connection

Attach base plate to round or square vertical extrusion using the bolt provided. Be careful not to strip the threads.

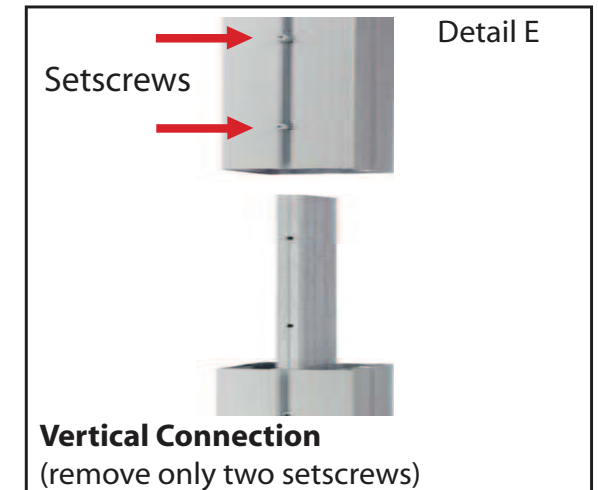

Detail E

Vertical Connection
(remove only two setscrews)

When vertical extrusions are packed in portable cases rather than crates or tubs, they must be broken down into smaller sections which then require assembly.

Remove only (2) setscrews when disassembling. Replace setscrews in extrusion after assembling it. Before packing, replace setscrews in extrusion to avoid losing them.

WHEN DISASSEMBLING ALUMINUM EXTRUSION, TIGHTEN ALL SETSCREWS AND LOCKS TO PREVENT LOSS DURING SHIPPING

866.652.2100

Item	Qty.	Description
1/1a	8/2	96" h Vertical Extrusion
2	2	96" h Vertical Extrusion
3	2	49.5" w Horizontal Extrusion w/ Velcro Attached to Back Bottom Edge of Extrusion
4	2	49.5" w Horizontal Extrusion w/ Velcro Attached to Back Top Edge of Extrusion
5	4	49.5" w Horizontal Extrusion
6	4	14" w Horizontal Extrusion w/ Velcro Attached to Back Bottom Edge of Extrusion
7	4	14" w Horizontal Extrusion w/ Velcro Attached to Back Top Edge of Extrusion
8	2	33.0261" w Curved Horizontal Extrusion w/ Velcro Attached to Back Bottom Edge of Extrusion
8a	2	33.0261" w Curved Horizontal Extrusion
9	2	33.0261" w Curved Horizontal Extrusion w/ Velcro Attached to Back Top Edge of Extrusion
10	1	57" w Horizontal Extrusion w/ Velcro Attached to Back Bottom Edge of Extrusion
11	1	57" w Horizontal Extrusion w/ Velcro Attached to Back Top Edge of Extrusion

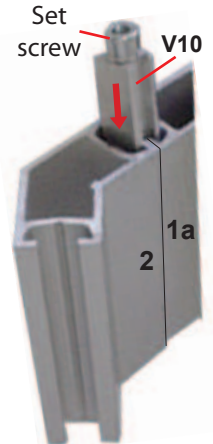

V10 Connection

Slide V10 Connector in between vertical extrusions. Tighten set screw to secure extrusions together.

Note: Usually packs assembled

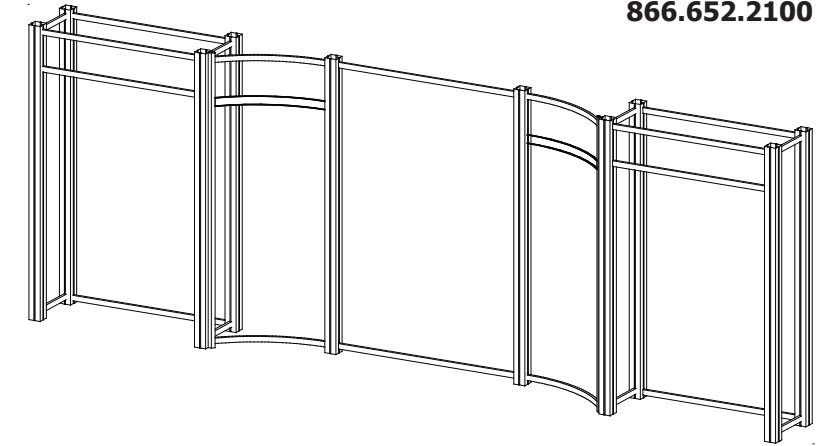

Steps:

- 1) Attach horizontal extrusions [3 and 4] between vertical extrusions [1].
- 2) Attach horizontal extrusions [6 and 7] between vertical extrusions [1 and 1a].
- 3) Attach horizontal extrusions [5] between vertical extrusions [1 and 1a].
- 4) Attach horizontal extrusions [8, 8a and 9] between vertical extrusions [1 and 1a/2].
- 5) Attach horizontal extrusions [10 and 11] between vertical extrusions [1].
- 6) Apply Graphics to back of extrusions as indicated.
- 7) Attach lights to assembled backwall.

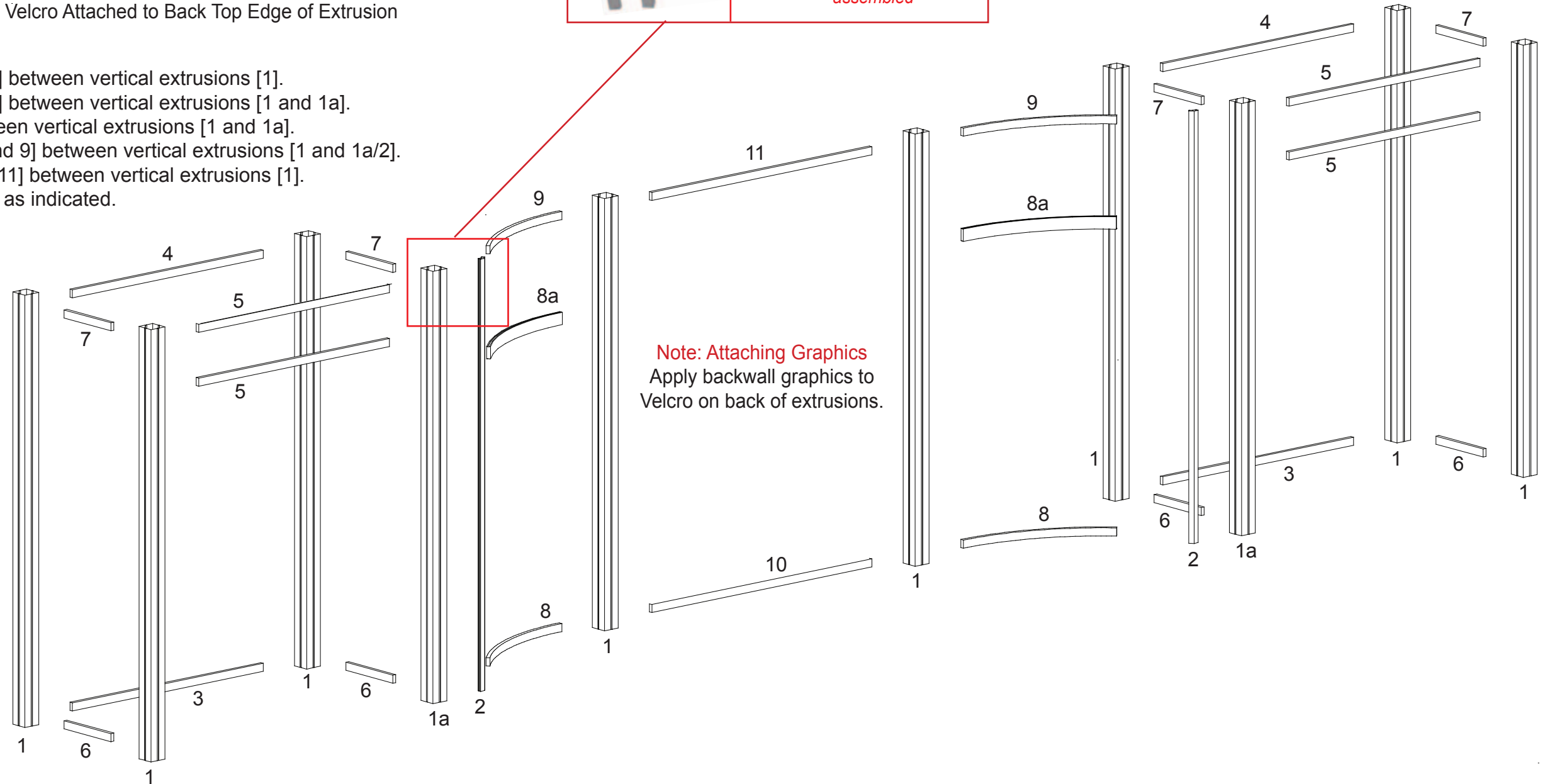

Note: Attaching Graphics
Apply backwall graphics to Velcro on back of extrusions.

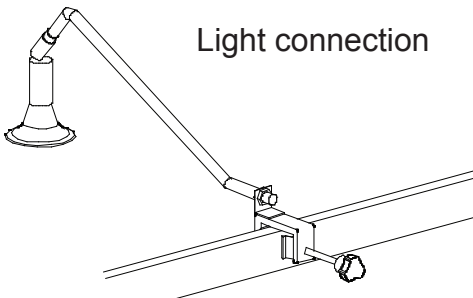

Light connection

Attach lights to assembled backwall as desired

WHEN DISASSEMBLING ALUMINUM EXTRUSION, TIGHTEN ALL SETSCREWS AND LOCKS TO PREVENT LOSS DURING SHIPPING