

WHEN DISASSEMBLING ALUMINUM EXTRUSION, TIGHTEN ALL SETSCREWS AND LOCKS TO PREVENT LOSS DURING SHIPPING

visionary™ DESIGNS

Using Your Setup Instructions

The Visionary Designs Setup Instructions are created specifically for your configuration. They are laid out sequentially, including an exploded view of the entire display, and then a logical series of detailed steps to assemble the main structure and components. We encourage you to study the instructions **before** attempting to assemble your exhibit.

Each page reminds you to tighten the setscrews after disassembling your exhibit to prevent loss of the locks and setscrews (see below in RED). This is **VERY IMPORTANT**.

Cleaning and Packing Your Display

- 1) Use care when cleaning aluminum extrusion or acrylic inserts. Use only non-abrasive cleaners.
- 2) When cleaning laminate inserts or countertops, use mild cleansers and a soft material such as cotton.
- 3) Keep all display components away from extreme heat and long exposure to sunlight to avoid warping and fading.
- 4) Retain all packing material. It will make re-packing much easier and will reduce the likelihood of shipping damage.



The Tool

Most Visionary Designs exhibits can be assembled with the supplied Hex Key Tool. Occasionally, a flat head screwdriver may be required.



Detail A

Typical Connection

Most horizontal extrusion connections have a patented expandable lock. This lock inserts into the groove of an opposing extrusion. Tightening the lock with the Hex Key Tool expands the lock and creates a strong positive connection.



Typical Connection (cont'd)

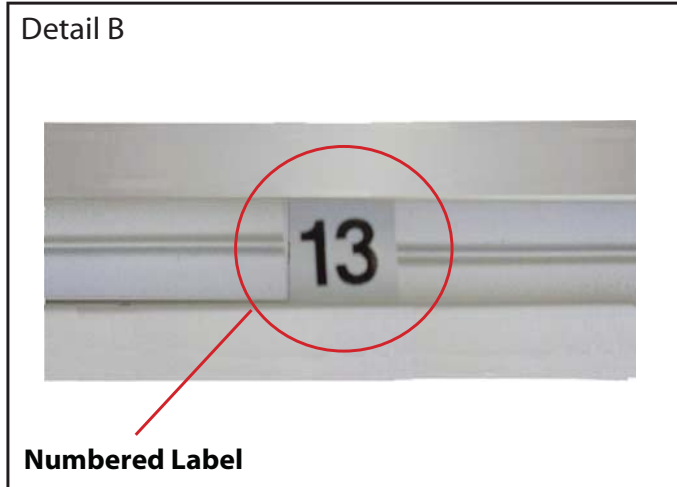

Detail B

Numbered Label

Each extrusion contains a numbered label which corresponds with setup instructions. The label is located within a groove of the extrusion (when possible). With Visionary Designs the labels contain Black numbers unless otherwise specified.



Detail C

Horizontal Inline Connection (remove only one setscrew)

Remove only (1) setscrew when disassembling. Replace setscrew in extrusion after assembling it. Before packing, replace setscrew in extrusion to avoid losing it.

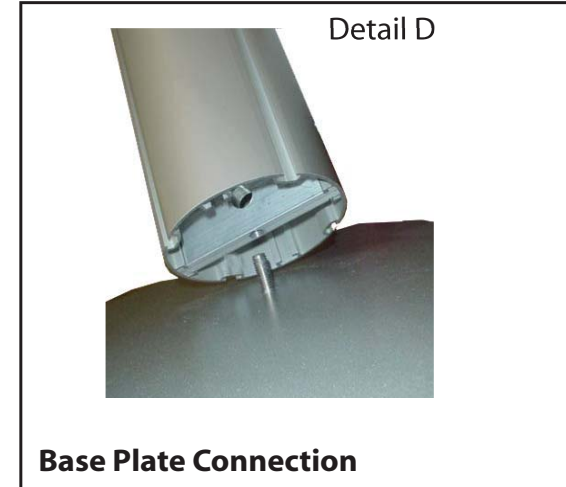

Detail D

Base Plate Connection

Attach base plate to round or square vertical extrusion using the bolt provided. Be careful not to strip the threads.

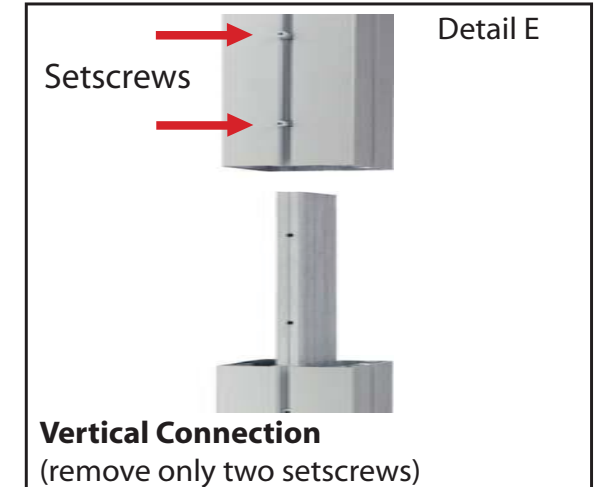

Detail E

Vertical Connection
(remove only two setscrews)

When vertical extrusions are packed in portable cases rather than crates or tubs, they must be broken down into smaller sections which then require assembly.

Remove only (2) setscrews when disassembling. Replace setscrews in extrusion after assembling it. Before packing, replace setscrews in extrusion to avoid losing them.

WHEN DISASSEMBLING ALUMINUM EXTRUSION, TIGHTEN ALL SETSCREWS AND LOCKS TO PREVENT LOSS DURING SHIPPING

Part Number	Qty for Step	Description
1	4	Base Plates w/ 2 Holes
2	2	Base Plates w/ 1 Hole
3	2	84" h Vertical Extrusion w/ Canopy Connection
4	2	84" h Vertical Extrusion w/ Canopy Connection
5	2	84" h Vertical Extrusion
6	2	48" h Vertical Extrusion
7	5	62" Lower Horizontal w/ Velcro attached to Top of member
8	5	62" Top Horizontal w/ Velcro attached to Bottom of member
9	4	40" Round Oval extrusion - Workstation Counter support
10	4	19" Tapered Horizontal extrusion - Workstation Counter support

Steps

- 1) Attach Vertical extrusions [3] and 40" Round Oval extrusion - Workstation Counter supports [9] to the Oval base plates [1].
- 2) Attach Vertical extrusions [4] o the Oval base plates [2].
- 3) Attach 19" Tapered Horizontal extrusion - Workstation Counter support [7] between 84" h Vertical [3] and 40" Round Oval extrusion [9].
- 4) Attach 62" Lower Horizontal extrusions [7] between Vertical extrusions [3, 4, and 5] as shown.
note: Velcro on Lower Horizontals must face UP.
- 5) Attach 62" Upper Horizontal extrusions [8] between Vertical extrusions [3, 4, and 5] as shown.
note: Velcro on Upper Horizontals must face DOWN.
- 6) Place Counter tops with Thumbscrews onto horizontal extrusion [10].

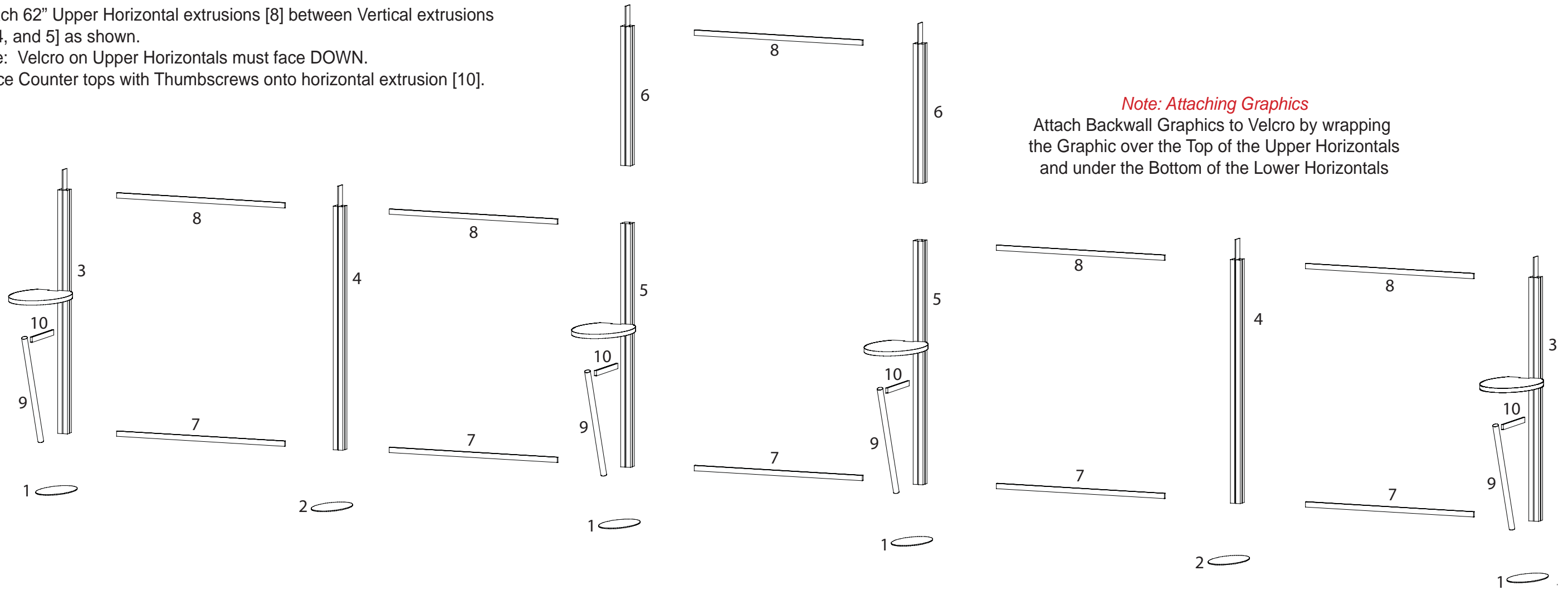

Note: Attaching Graphics
Attach Backwall Graphics to Velcro by wrapping the Graphic over the Top of the Upper Horizontals and under the Bottom of the Lower Horizontals

WHEN DISASSEMBLING ALUMINUM EXTRUSION, TIGHTEN ALL SETSCREWS AND LOCKS TO PREVENT LOSS DURING SHIPPING

Item	Quantity	Description
A	1	39" Round formed extrusion
AB	1	39" Round formed extrusion
B	1	39" Round fomred extrusion
C	1	39" Round formed extrusion
CD	1	39" Round formed extrusion
D	1	39" Round formed extrusion
E	2	14" Round extrusion
F	1	14" Round extrusion

Steps:

- 1) Connect 39" (A) round formed extrusion to 39" (A) round formed extrusion.
- 2) Connect 39" (B) round formed extrusion to 39" (B) round formed extrusion.
- 3) Connect 39" (C) round formed extrusion to 39" (C) round formed extrusion.
- 4) Connect 39" (D) round formed extrusion to 39" (D) round formed extrusion.
- 5) Connect (A) round formed extrusion and (D) round formed extrusion to 14" (E) extrusion.
- 6) Connect (B) round formed extrusion and (C) round formed extrusion to 14" (E) extrusion.
- 7) Connect (AB) round formed extrusion and (CD) round formed extrusion to 14" (F) extrusion.
- 8) Attach Canopy Assembly to Vertical extrusions with Canopy attachments.

Repeat steps 1-8 for all three Canopies rusing to the correct color labeling.

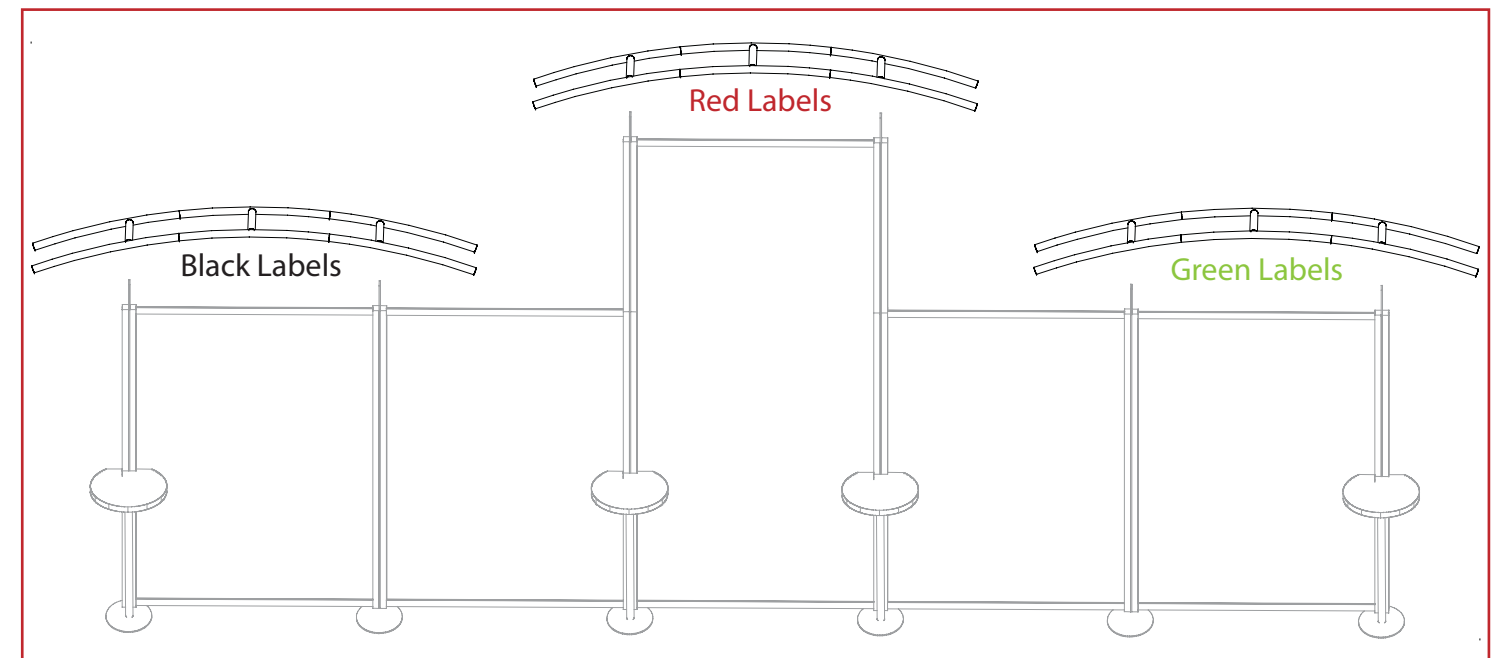
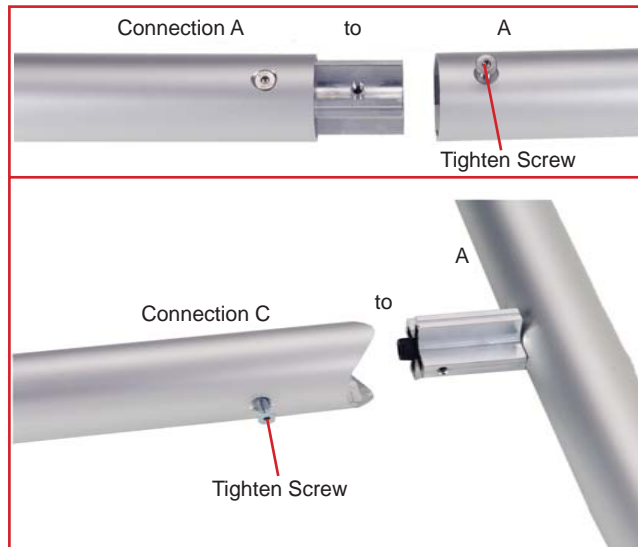
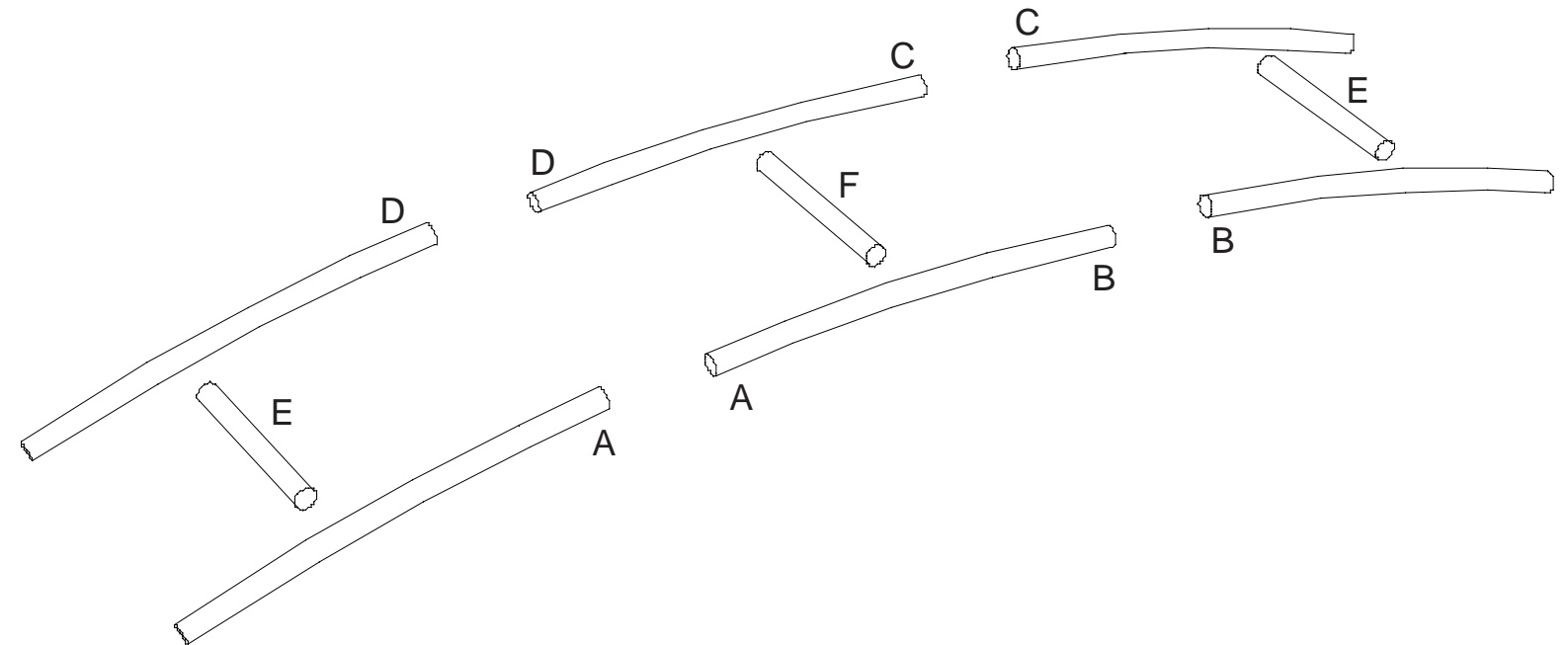

WHEN DISASSEMBLING ALUMINUM EXTRUSION, TIGHTEN ALL SETSCREWS AND LOCKS TO PREVENT LOSS DURING SHIPPING