

General Layout - Order #23745 - Reconfigure

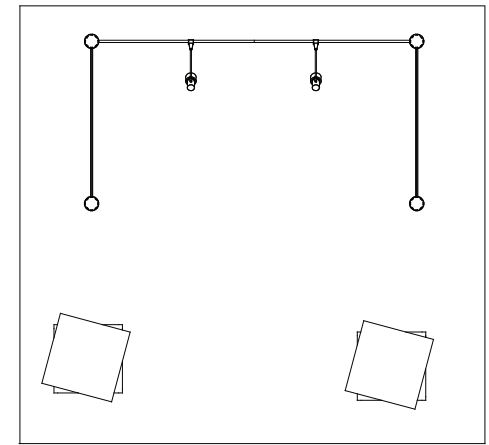

NOTE: WHEN DISASSEMBLING EXTRUSION TIGHTEN ALL LOCKS TO PREVENT LOSS OF SETSCREWS

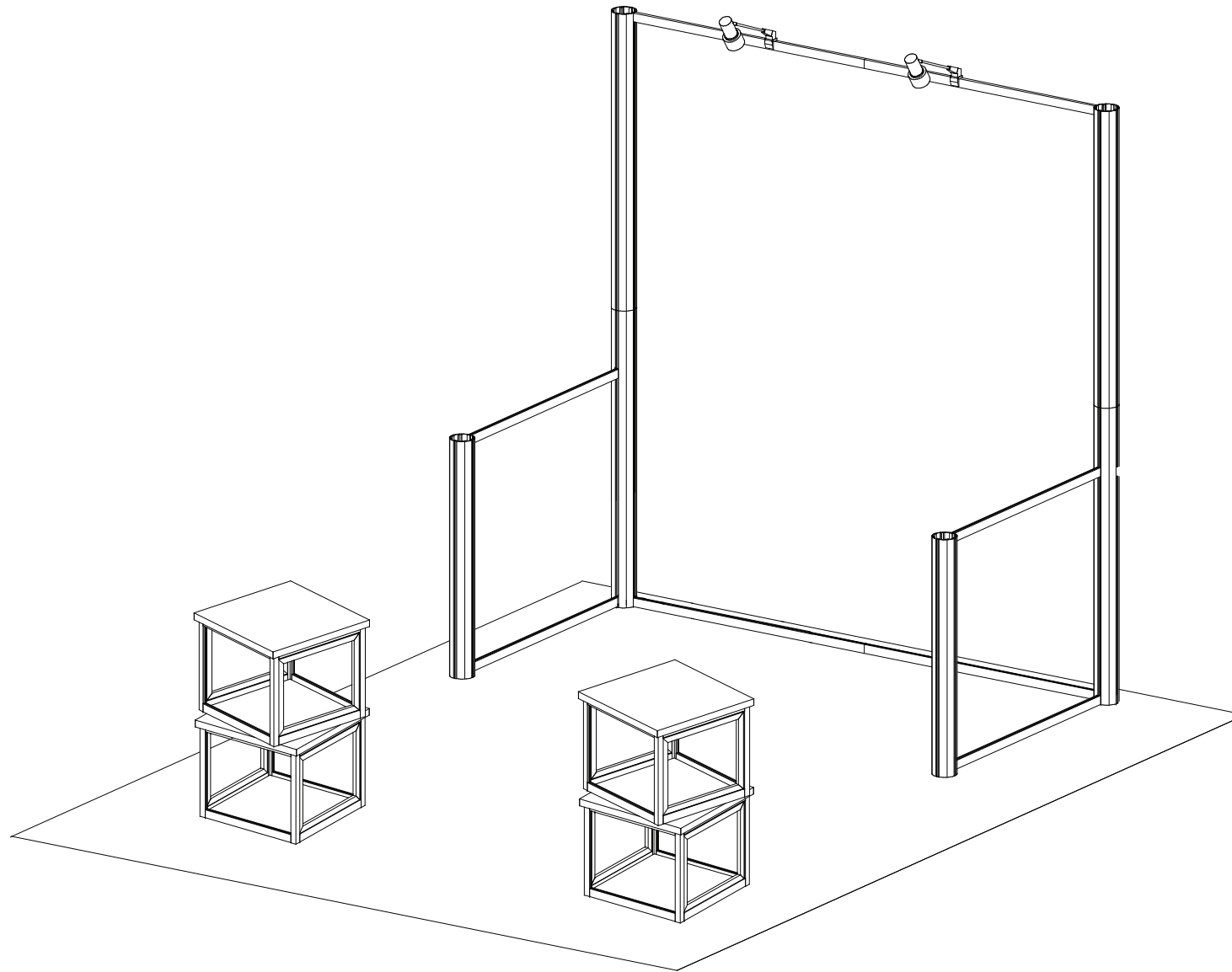

Using Your Setup Instructions

The Visionary Designs Setup Instructions are created specifically for your configuration. They are laid out sequentially, including an exploded view of the entire display, and then a logical series of detailed steps to assemble the main structure and components. We encourage you to study the instructions **before** attempting to assemble your exhibit.

Each page reminds you to tighten the setscrews after disassembling your exhibit to prevent loss of the locks and setscrews (see below in RED). This is VERY IMPORTANT.

Cleaning and Packing Your Display

- 1) Use care when cleaning aluminum extrusion or acrylic inserts. Use only non-abrasive cleaners.
- 2) When cleaning laminate inserts or countertops, use mild cleansers and a soft material such as cotton.
- 3) Keep all display components away from extreme heat and long exposure to sunlight to avoid warping and fading.
- 4) Retain all packing material. It will make re-packing much easier and will reduce the likelihood of shipping damage.

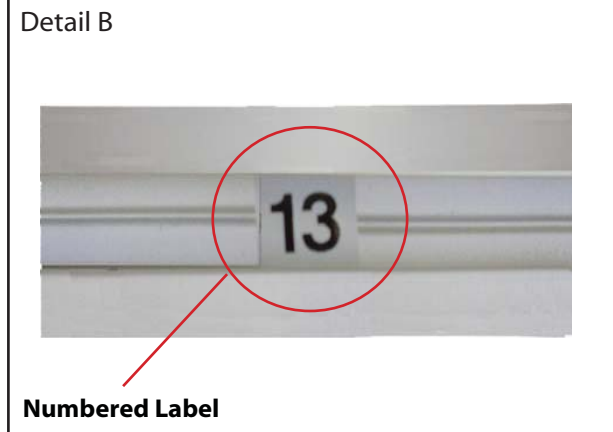

Each extrusion contains a numbered label which corresponds with setup instructions. The label is located within a groove of the extrusion (when possible). With Visionary Designs the labels contain Black numbers unless otherwise specified.



Remove only (1) setscrew when disassembling. Replace setscrew in extrusion after assembling it. Before packing, replace setscrew in extrusion to avoid losing it.

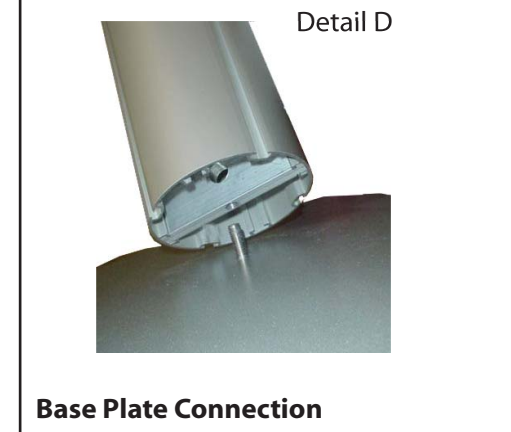

Attach base plate to round or square vertical extrusion using the bolt provided. Be careful not to strip the threads.

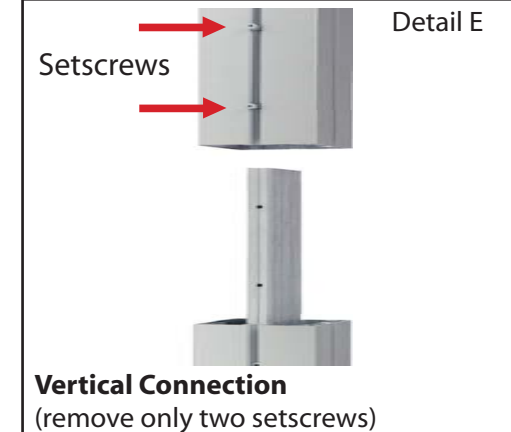

When vertical extrusions are packed in portable cases rather than crates or tubs, they must be broken down into smaller sections which then require assembly.

Remove only (2) setscrews when disassembling. Replace setscrews in extrusion after assembling it. Before packing, replace setscrews in extrusion to avoid losing them.

Visionary Designs General Setup Instructions - Order



Most Visionary Designs exhibits can be assembled with the supplied Hex Key Tool. Occasionally, a flat head screwdriver may be required.



Most horizontal extrusion connections have a patented expandable lock. This lock inserts into the groove of an opposing extrusion. Tightening the lock with the Hex Key Tool expands the lock and creates a strong positive connection.



WHEN DISASSEMBLING ALUMINUM EXTRUSION, TIGHTEN ALL SETSCREWS AND LOCKS TO PREVENT LOSS DURING SHIPPING



Backwall Assembly - Order #23745 - Step 1 of 2

Item	Quantity	Description
1	2	48" h Vertical Extrusion
3	2	60" h Vertical Extrusion
4	2	60" h Vertical Extrusion
5	4	51" w Horizontal Extrusion
6	2	53.5" w Horizontal Extrusion
7	2	53.5" w Horizontal Extrusion

Steps:

- 1) Attach horizontal extrusions #5 to vertical extrusions #'s 1 and 3.
- 2) Attach vertical extrusions #4 to vertical extrusions #3 as shown in illustration.
- 3) Connect horizontal extrusions #6 to #7. Attach to vertical extrusions #3/4 as shown in illustration.

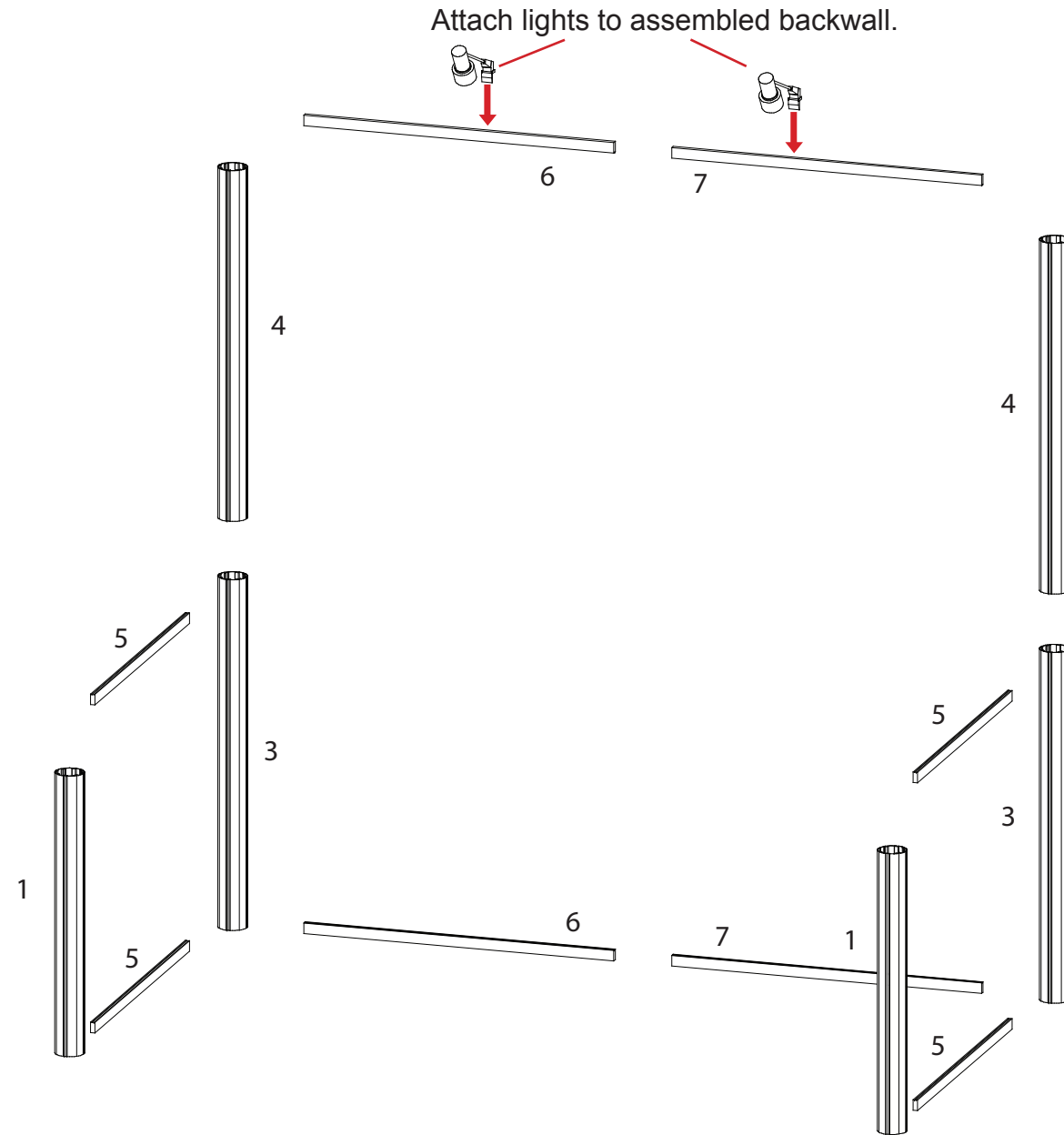

NOTE: WHEN DISASSEMBLING EXTRUSION TIGHTEN ALL LOCKS TO PREVENT LOSS OF SETSCREWS



Cubed Pedestal Assembly - Order #23745 - Step 2 of 2

Item	Quantity	Description
19	4	21" w Horizontal Extrusion
20	4	21" w Horizontal Extrusion
21	2	21" h Vertical Extrusion
22	2	21" h Vertical Extrusion
23	2	21" h Vertical Extrusion
24	2	21" h Vertical Extrusion
25	8	21" w Horizontal Extrusion

Steps:

- 1) Connect horizontal extrusions #19 between vertical extrusions #21, 22, 23 and 24.
- 2) Attach provided pins to horizontal extrusions #19 as shown.
- 3) Set floor atop pins, and set counter atop assembled pedestal.
- 4) Connect lower horizontal extrusions #25 between vertical extrusions #21, 22, 23 and 24.
- 5) Attach doors as shown, then attach upper horizontal extrusions #20 between vertical extrusions #21, 22, 23 and 24, and atop doors
- 6) Place upper cubed pedestal floor on top of lower pedestal.
- 7) Set upper assembled pedestal atop lower pedestal, then set counter atop assembled pedestal.

Repeat steps for 2nd cubed pedestal.

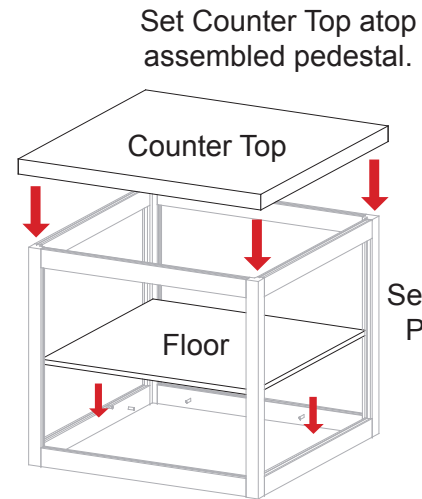
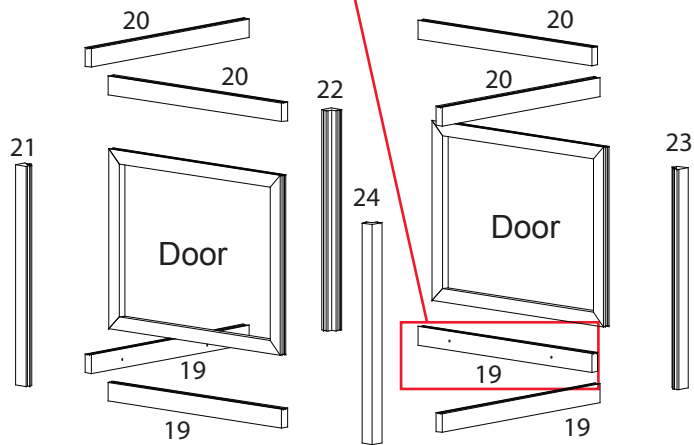
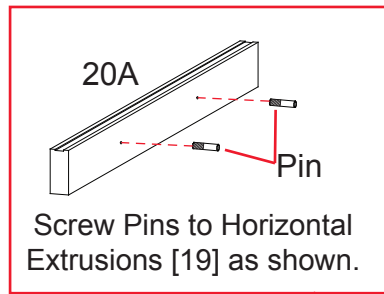

Set Lower Cubed Pedestal Floor atop pins.

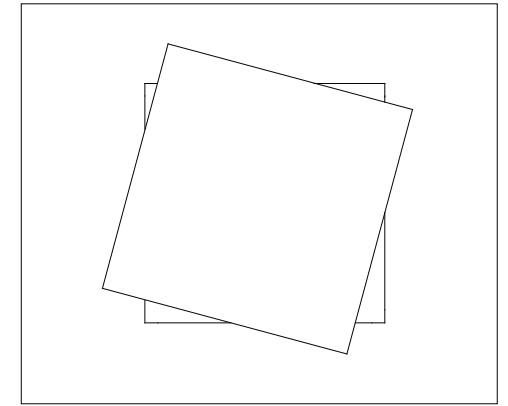
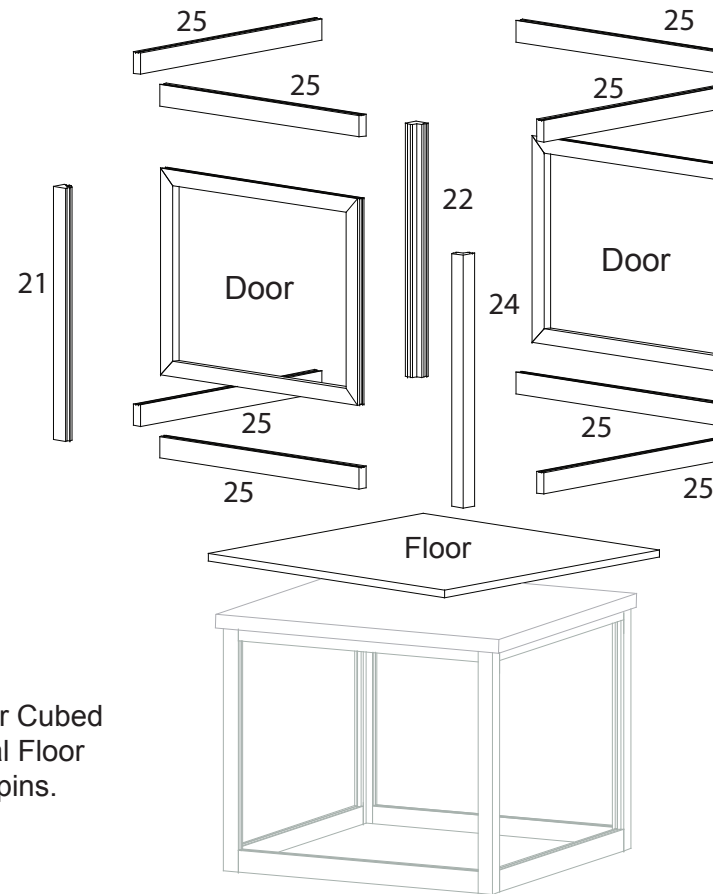

Set Counter atop Assembled Pedestal

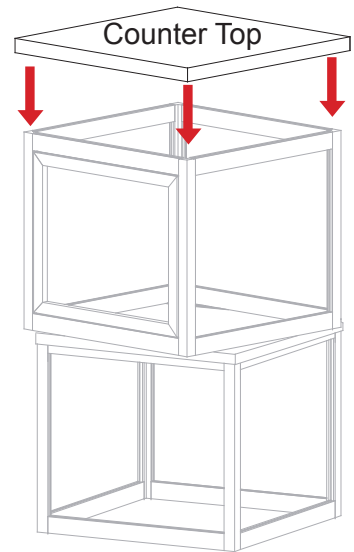

NOTE: WHEN DISASSEMBLING EXTRUSION TIGHTEN ALL LOCKS TO PREVENT LOSS OF SETSCREWS

