

# Entrance Arcs Assembly - Order #27186

Item	Quantity	Description
56	1	70.625"w Horizontal Extrusion
57	1	27.125"w Horizontal Extrusion
58	1	8"w Horizontal Extrusion
59	1	Curved Vertical Extrusion
60	1	70.625"w Horizontal Extrusion
61	1	27.125"w Horizontal Extrusion
62	1	8"w Horizontal Extrusion
63	1	Curved Vertical Extrusion

## Steps:

- 1) Connect extrusions #57 and 58 between vertical extrusion #56 and 59.
- 2) Connect extrusions #61 and 62 between vertical extrusion #60 and 63.

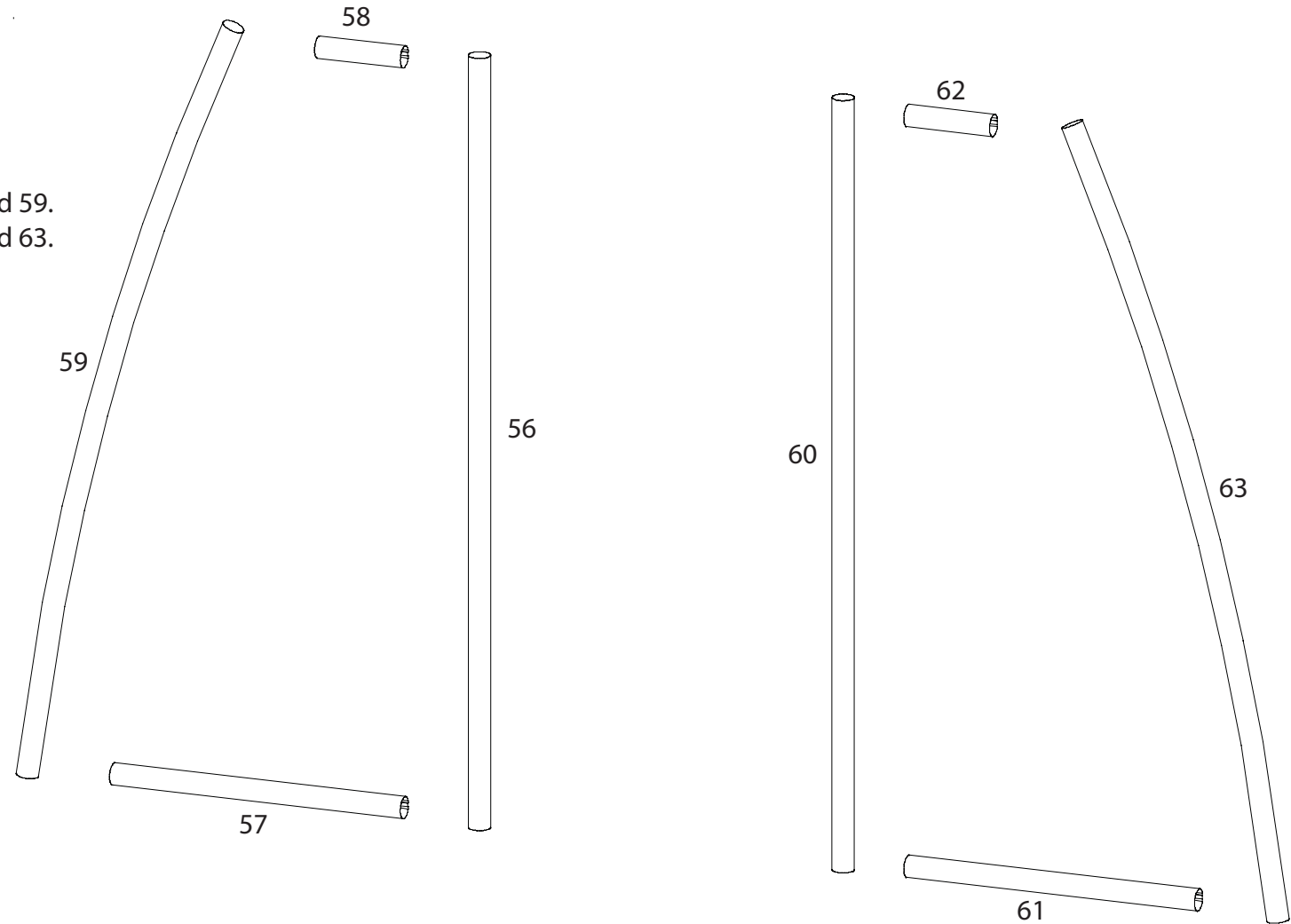

**NOTE: WHEN DISASSEMBLING EXTRUSION TIGHTEN ALL LOCKS TO PREVENT LOSS OF SETSCREWS**



# MF1 Wall Additions - Wall Assembly - Order #27186

Item	Quantity	Description
40	1	96.458" w Square Horizontal Extrusion
41	1	96.458" w Square Horizontal Extrusion
42	1	96.458" w Square Horizontal Extrusion
43	1	96.458" w Square Horizontal Extrusion
44	1	96.458" w Square Horizontal Extrusion
45	1	96.458" w Square Horizontal Extrusion
46	5	54.292" w Square Horizontal Extrusion
47	5	55.9795" h Square Vertical Extrusion
48	5	55.9795" h Square Vertical Extrusion

## Steps:

- 1) Connect horizontal extrusions # 40 - 42 and #43 - 45 together as shown in illustration.
- 2) Connect vertical extrusions #47 to 48.
- 3) Connect first assembled extrusions #47/48 to end of #42.
- 4) Continue on connecting horizontal extrusions #46 between vertical assemblies #47/48 as shown in illustration.
- 5) Connect assembled horizontal #43/44/45 to tops of vertical extrusion assemblies #47/48.

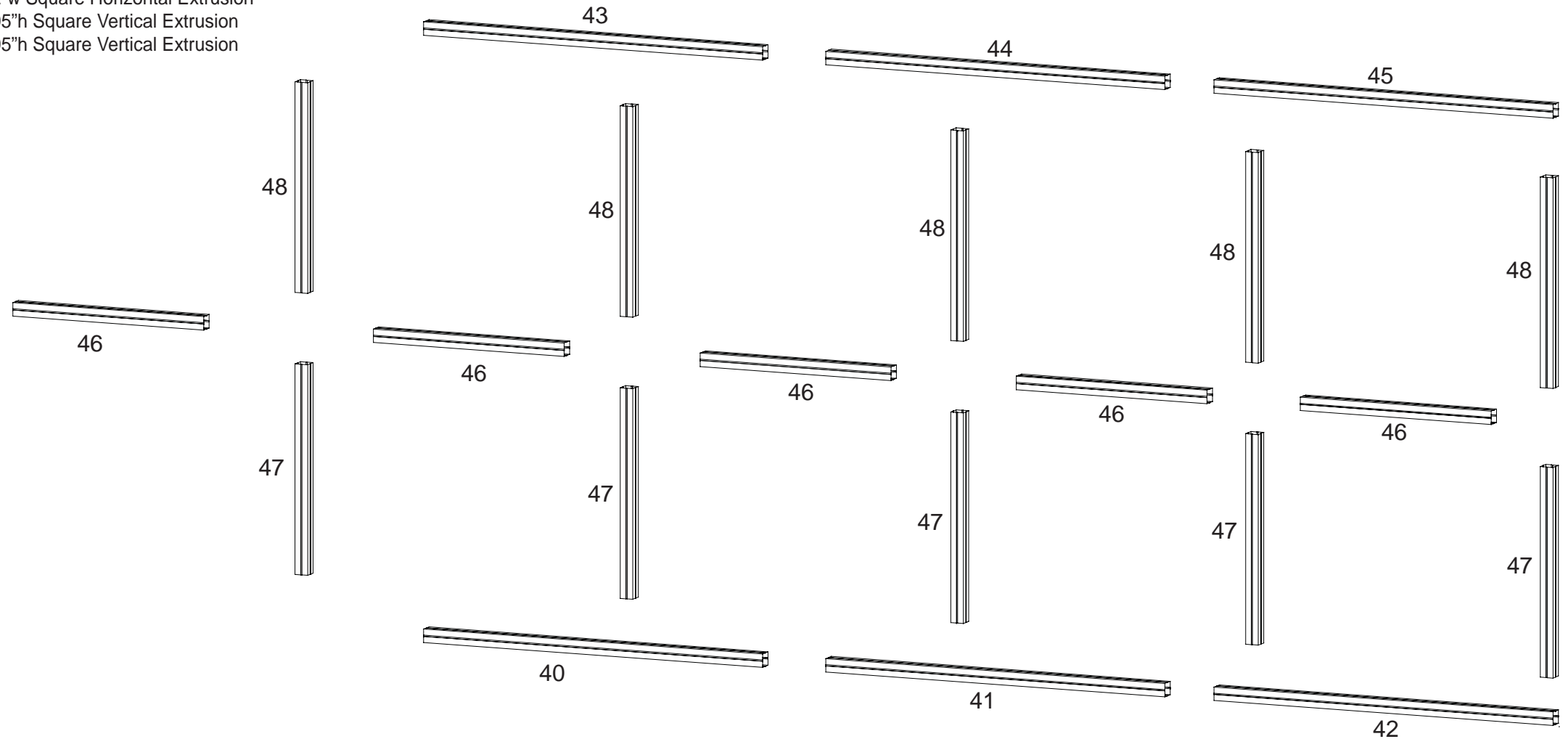

**NOTE: WHEN DISASSEMBLING EXTRUSION TIGHTEN ALL LOCKS TO PREVENT LOSS OF SETSCREWS**



# MF4 Wall Additions - Wall Assembly - Order #27186

Item	Quantity	Description
52	2	84.3965" Square Horizontal Extrusion
53	2	72" Square Vertical Extrusion
54	1	64.834" Square Vertical Extrusion
55	2	40.4073" Square Horizontal Extrusion

## Steps:

- 1) Connect vertical extrusions #55 to center of vertical extrusion #54.
- 2) Connect vertical extrusions #53 to horizontal extrusion #52.
- 3) Connect vertical assembly #54/55 between vertical extrusions #53 and atop horizontal extrusion #52.
- 4) Connect horizontal extrusion #52 atop vertical extrusions #53 and 54.

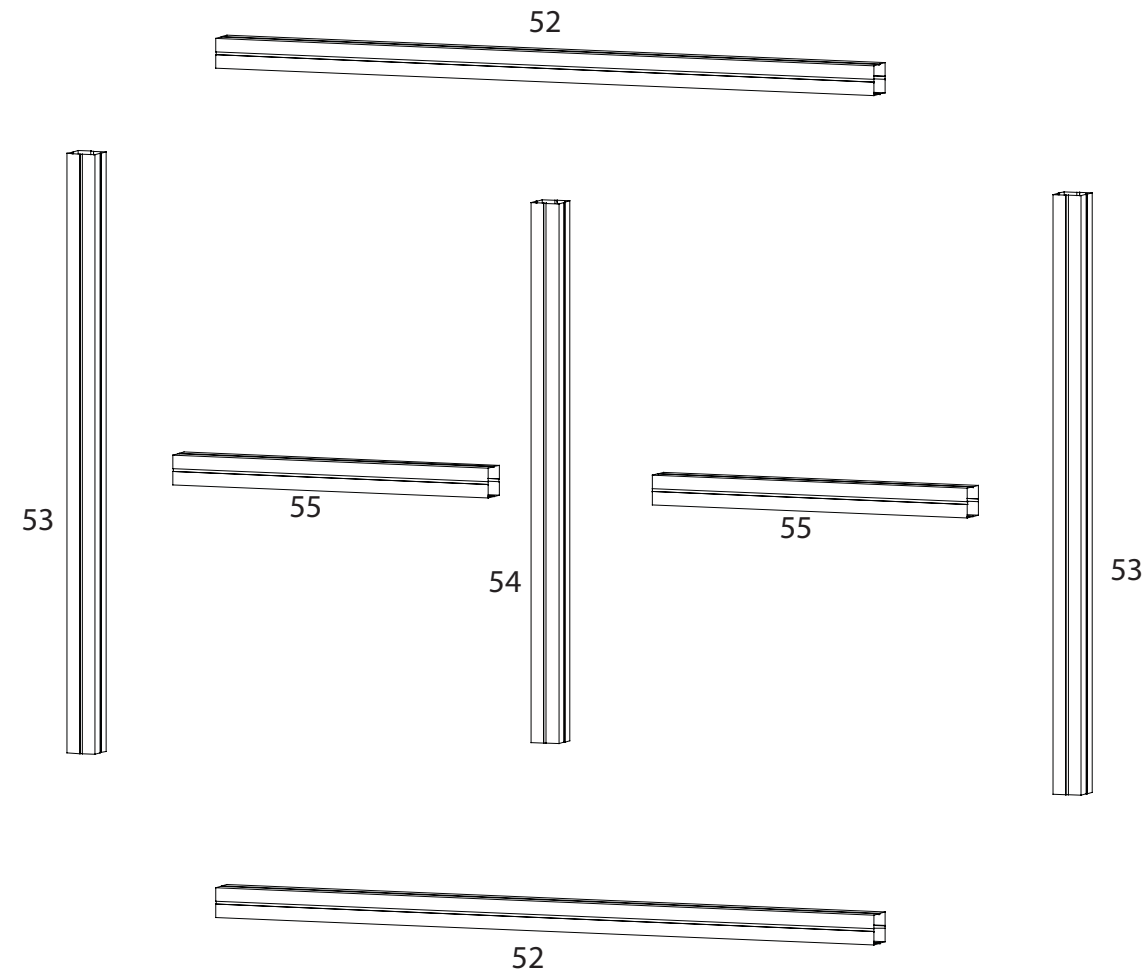

**NOTE: WHEN DISASSEMBLING EXTRUSION TIGHTEN ALL LOCKS TO PREVENT LOSS OF SETSCREWS**



# MF2 Wall Additions - Wall Assembly - Order #27186

Item	Quantity	Description
49	1	62.0625"w Square Vertical Extrusion
50	1	62.0625"w Square Vertical Extrusion
51	3	28"h Square Horizontal Extrusion

- Steps:
- 1) Connect vertical extrusions # 49 to 50 together.
  - 2) Connect horizontal extrusions #51 to assembled vertical extrusions #49/50 at desired locations.

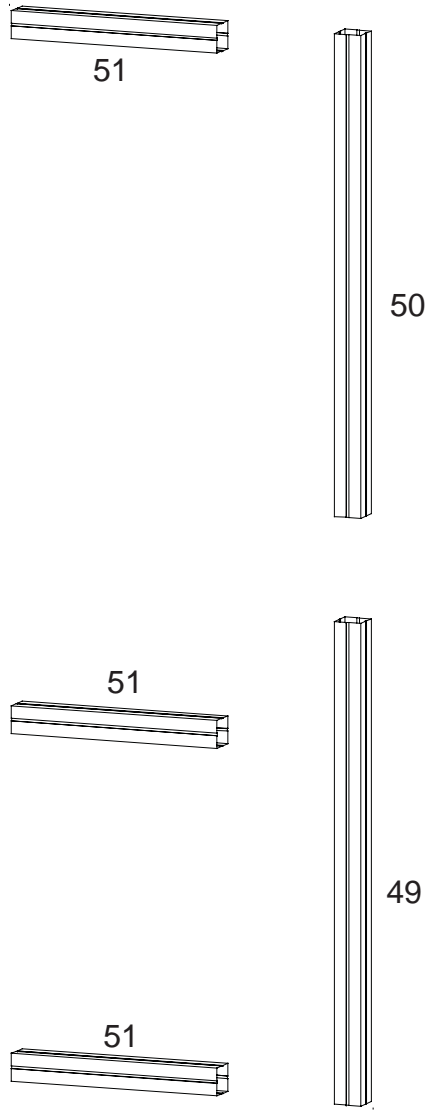

**NOTE: WHEN DISASSEMBLING EXTRUSION TIGHTEN ALL LOCKS TO PREVENT LOSS OF SETSCREWS**