

WHEN DISASSEMBLING ALUMINUM EXTRUSION, TIGHTEN ALL SETSCREWS AND LOCKS TO PREVENT LOSS DURING SHIPPING

visionary™ IDESIGNS

Using Your Setup Instructions

The Visionary Designs Setup Instructions are created specifically for your configuration. They are laid out sequentially, including an exploded view of the entire display, and then a logical series of detailed steps to assemble the main structure and components. We encourage you to study the instructions **before** attempting to assemble your exhibit.

Each page reminds you to tighten the setscrews after disassembling your exhibit to prevent loss of the locks and setscrews (see below in RED). This is **VERY IMPORTANT**.

Cleaning and Packing Your Display

- 1) Use care when cleaning aluminum extrusion or acrylic inserts. Use only non-abrasive cleaners.
- 2) When cleaning laminate inserts or countertops, use mild cleansers and a soft material such as cotton.
- 3) Keep all display components away from extreme heat and long exposure to sunlight to avoid warping and fading.
- 4) Retain all packing material. It will make re-packing much easier and will reduce the likelihood of shipping damage.



The Tool

Most Visionary Designs exhibits can be assembled with the supplied Hex Key Tool. Occasionally, a flat head screwdriver may be required.



Typical Connection

Most horizontal extrusion connections have a patented expandable lock. This lock inserts into the groove of an opposing extrusion. Tightening the lock with the Hex Key Tool expands the lock and creates a strong positive connection.



Typical Connection (cont'd)

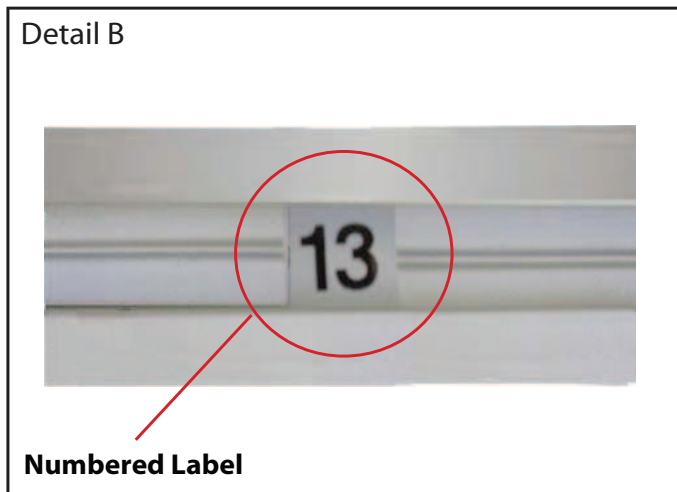

Detail B

Numbered Label

Each extrusion contains a numbered label which corresponds with setup instructions. The label is located within a groove of the extrusion (when possible). With Visionary Designs the labels contain Black numbers unless otherwise specified.



Detail C

Horizontal Inline Connection (remove only one setscrew)

Remove only (1) setscrew when disassembling. Replace setscrew in extrusion after assembling it. Before packing, replace setscrew in extrusion to avoid losing it.

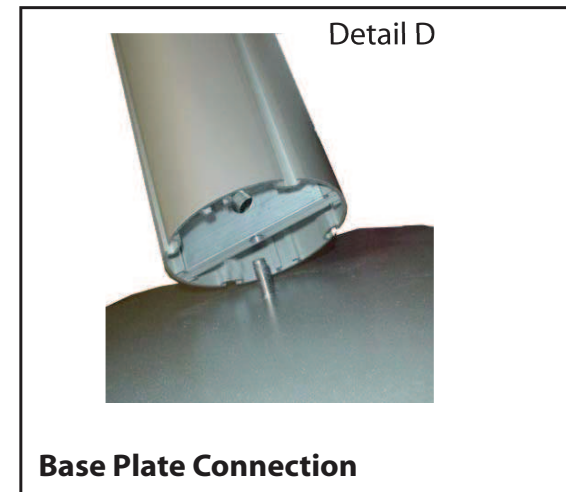

Detail D

Base Plate Connection

Attach base plate to round or square vertical extrusion using the bolt provided. Be careful not to strip the threads.

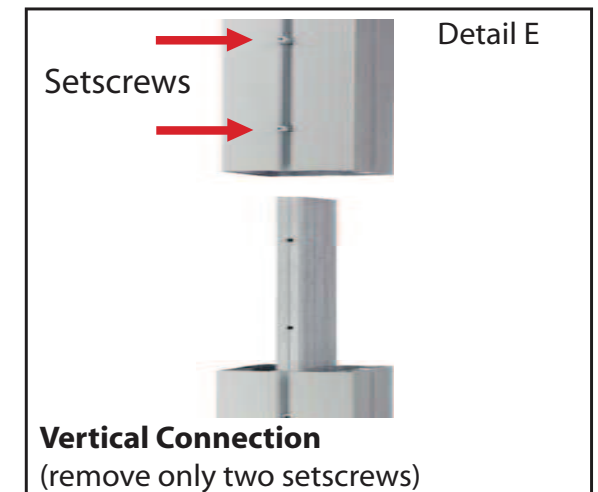

Detail E

Vertical Connection
(remove only two setscrews)

When vertical extrusions are packed in portable cases rather than crates or tubs, they must be broken down into smaller sections which then require assembly.

Remove only (2) setscrews when disassembling. Replace setscrews in extrusion after assembling it. Before packing, replace setscrews in extrusion to avoid losing them.

WHEN DISASSEMBLING ALUMINUM EXTRUSION, TIGHTEN ALL SETSCREWS AND LOCKS TO PREVENT LOSS DURING SHIPPING

Item	Qty.	Description
1	1	48”h Vertical Extrusion w/ Ornamental Attachment
2	2	48”h Vertical Extrusion
3	1	48”h Vertical Extrusion w/ Ornamental Attachment
4	2	20”w Curved Horizontal Extrusion
5	1	33.75”w Curved Horizontal Extrusion
6	2	20”w Curved Horizontal Extrusion w/ Attached Velcro to Back of Extrusion
7	1	33.75”w Curved Horizontal Extrusion w/ Attached Velcro to Back of Extrusion
8	2	20”w Curved Horizontal Extrusion w/ Attached Velcro to Back of Extrusion
9	1	33.75”w Curved Horizontal Extrusion w/ Attached Velcro to Back of Extrusion

866.652.2100

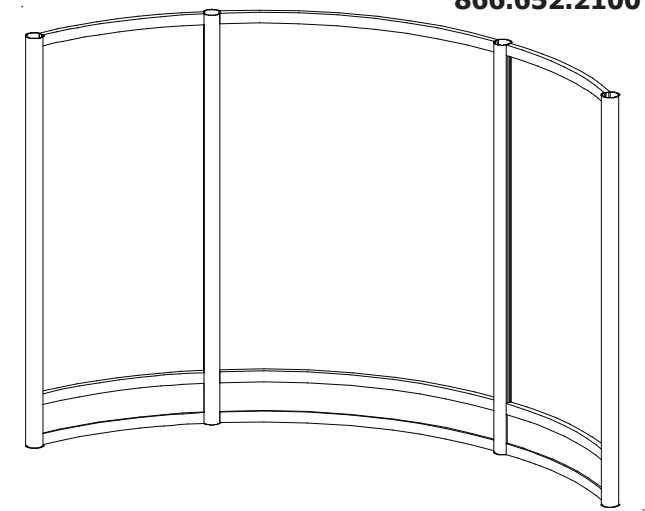

Steps:

- 1) Slide ornamental onto vertical extrusions [1 and 3], see Ornamental Attachment detail.
- 2) Attach horizontal extrusion [5] between vertical extrusions [2].
- 3) Attach horizontal extrusions [4] between vertical extrusions [1,2 and 3].
- 4) Place perforated metal insert into grooves of extrusion atop horizontal extrusions [4 and 5] as shown.
- 5) Attach horizontal extrusions [6] between vertical extrusions [1,2 and 3] and horizontal extrusion [7] between vertical extrusions [2].
- 6) Attach horizontal extrusions [8] between vertical extrusions [1 and 2] and horizontal extrusion [9] between vertical extrusions [2].

Note: Attach horizontal extrusions [8 and 9] flush with top of vertical extrusions.

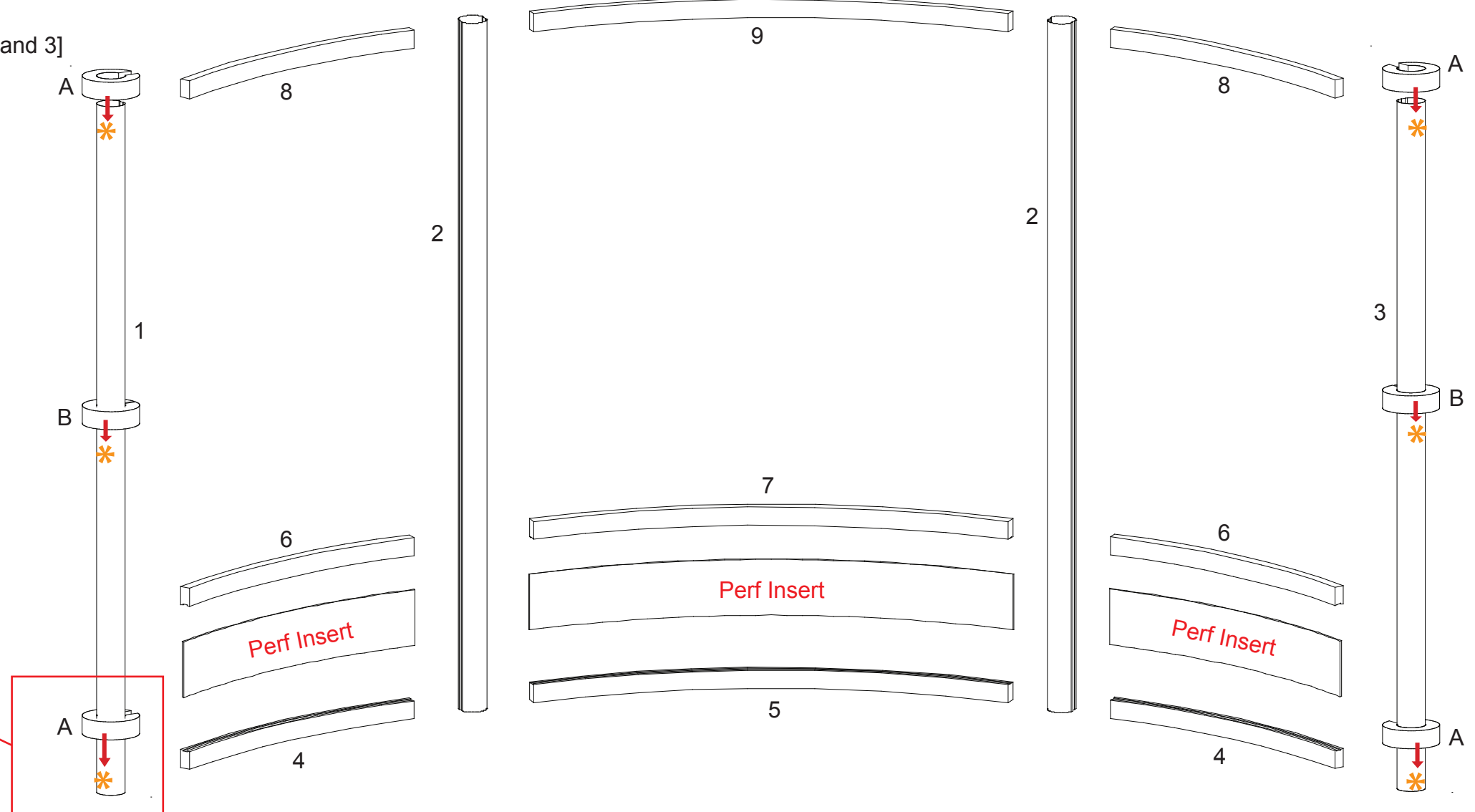
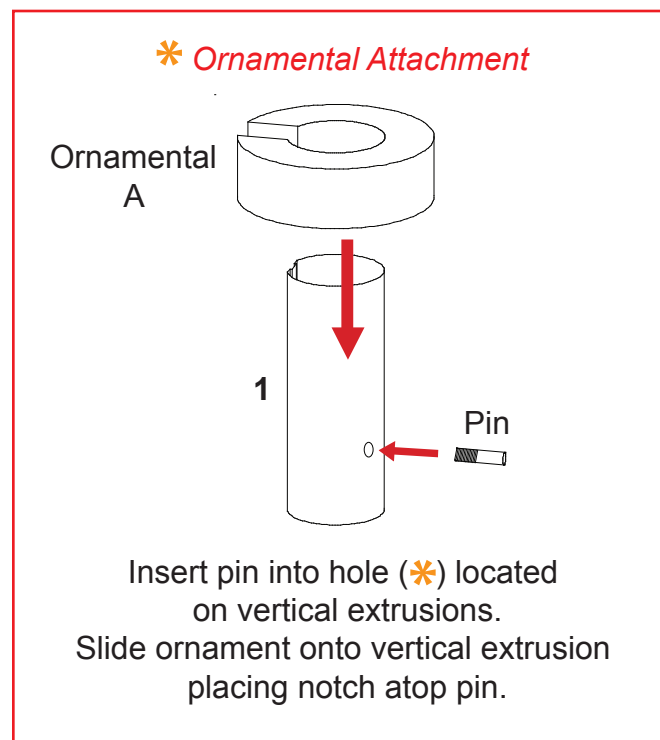

WHEN DISASSEMBLING ALUMINUM EXTRUSION, TIGHTEN ALL SETSCREWS AND LOCKS TO PREVENT LOSS DURING SHIPPING

866.652.2100

Item	Qty.	Description
10	1	36.35" w Curved Horizontal Extrusion w/ Attached Steel Tape to Front of Extrusion
11	1	36.35" w Curved Horizontal Extrusion w/ Attached Steel Tape to Front of Extrusion
12	1	6.48" h Vertical Extrusion w/ Attached Steel Tape to Front of Extrusion
13	1	6.48" h Vertical Extrusion w/ Attached Steel Tape to Front of Extrusion

Steps:

- 1) Header Assembly: Attach vertical extrusions [12 and 13] between curved horizontal extrusions [10 and 11].
- 2) Hook assembled header to top of vertical extrusions [2] as shown.

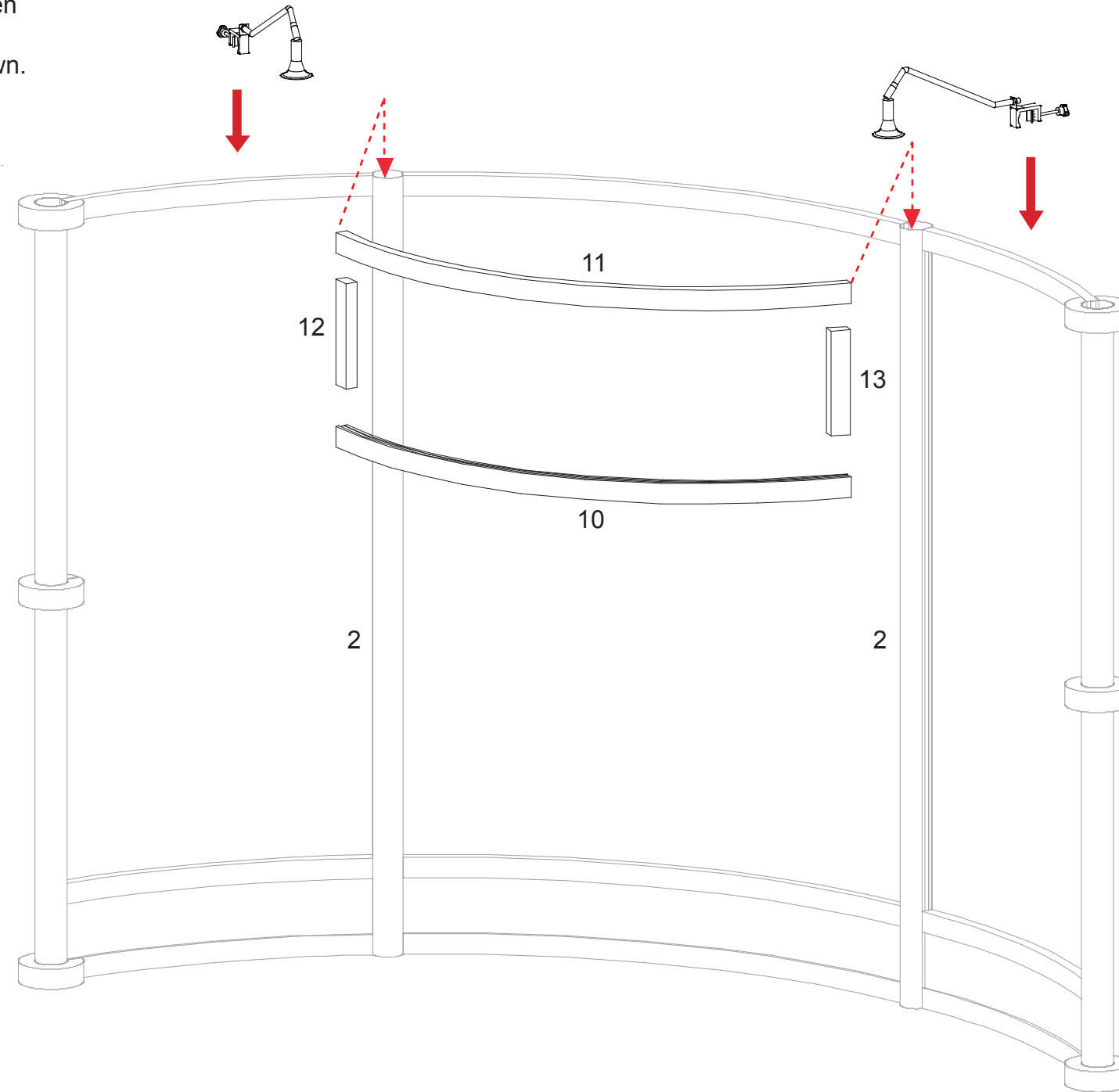
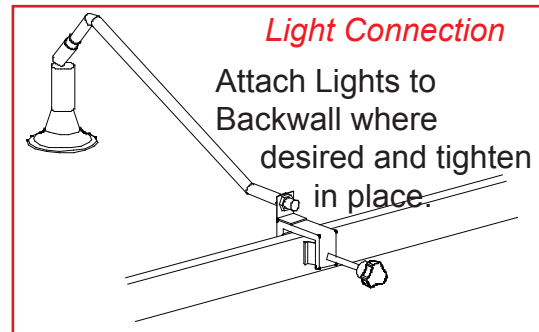
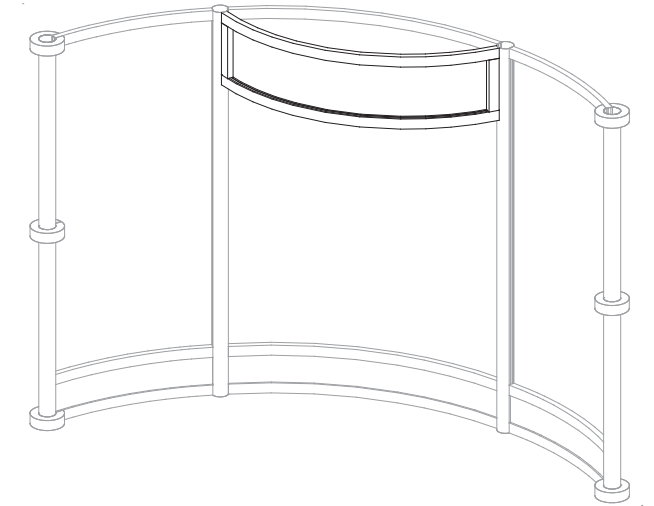

WHEN DISASSEMBLING ALUMINUM EXTRUSION, TIGHTEN ALL SETSCREWS AND LOCKS TO PREVENT LOSS DURING SHIPPING

NOTE :

PDF copies of your Setup Instructions are available @ classicexhibits.com
See the search tool on the lower left hand corner of the Home page.

Enter the 5 digit Order #.

Search for Setup Instructions

WHEN DISASSEMBLING ALUMINUM EXTRUSION, TIGHTEN ALL
SETSCREWS AND LOCKS TO PREVENT LOSS DURING SHIPPING