

euro It | HYBRIDS

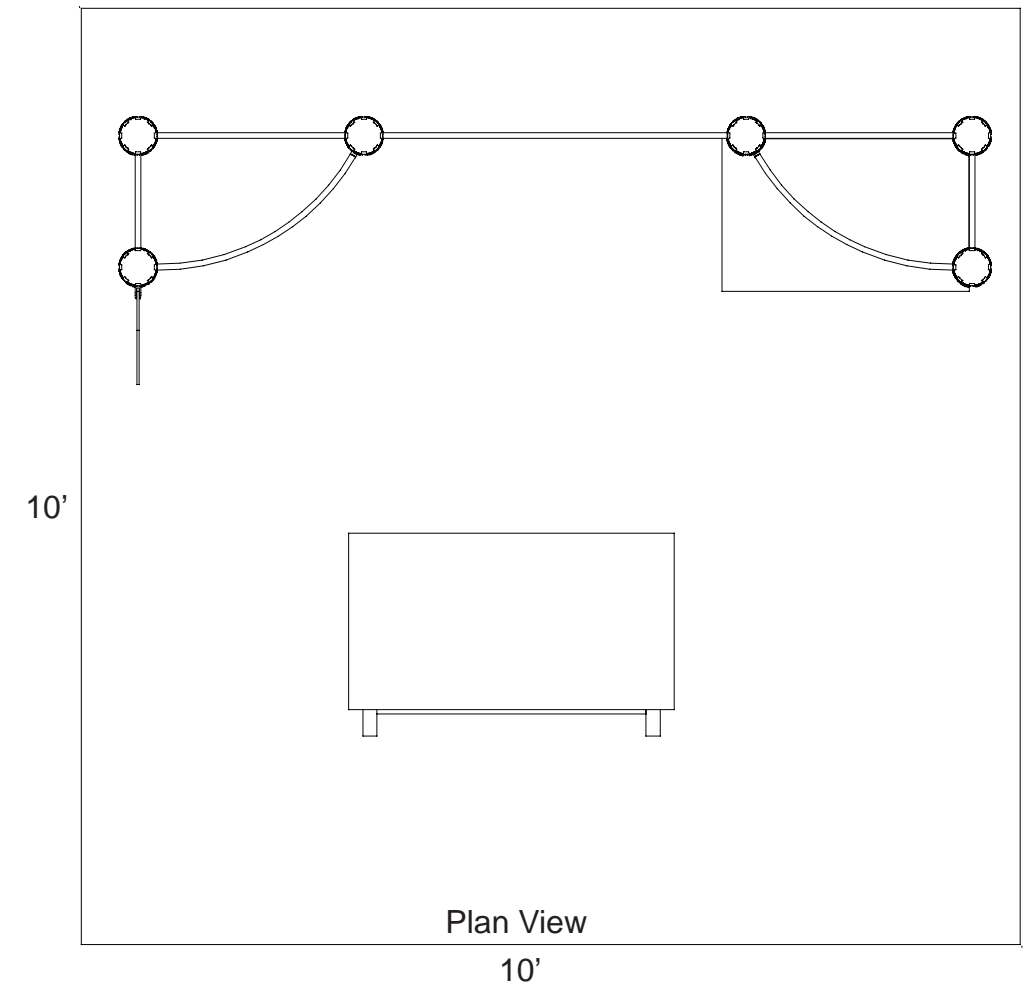
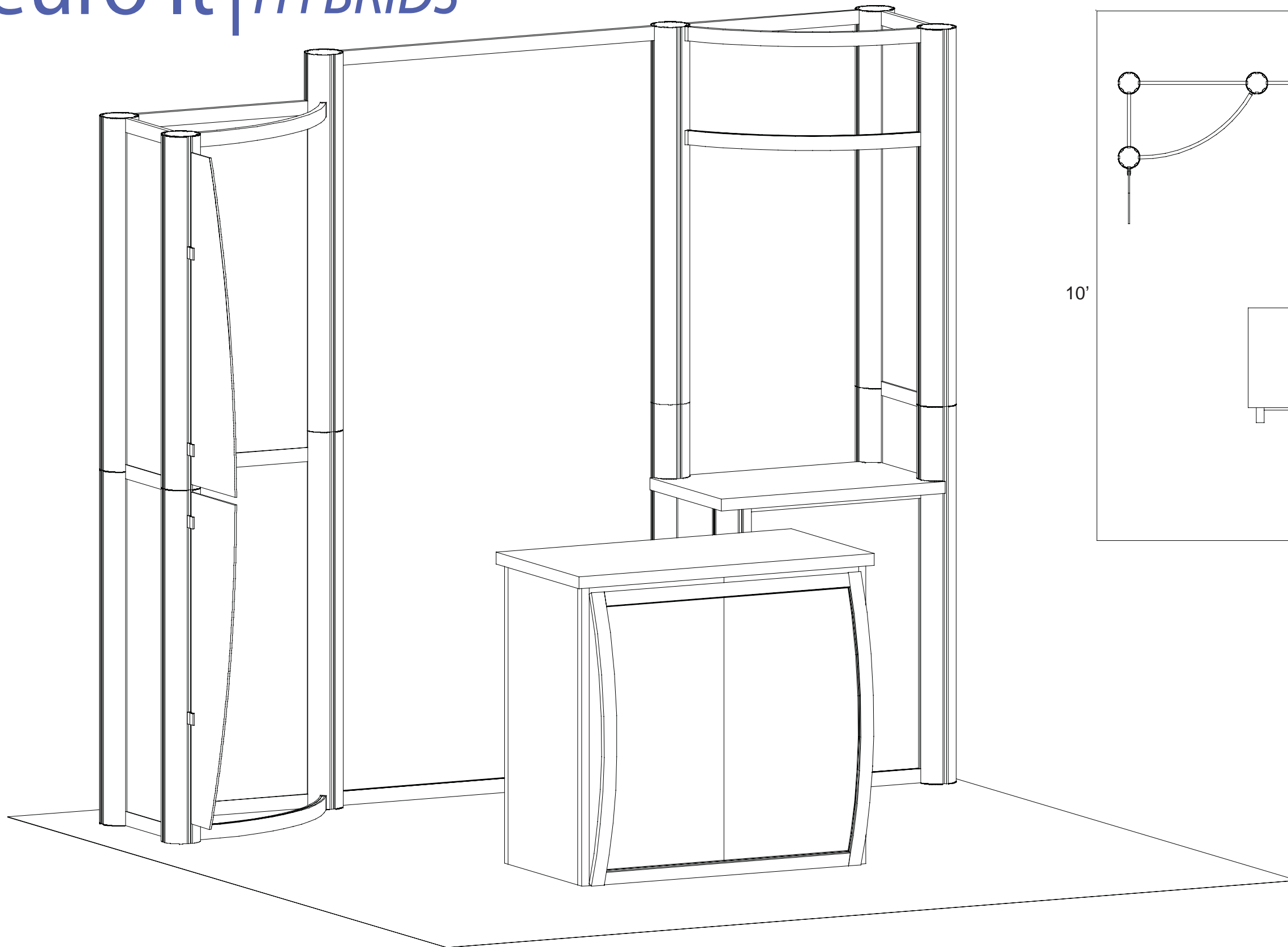

WHEN DISASSEMBLING ALUMINUM EXTRUSION, TIGHTEN ALL SETSCREWS AND LOCKS TO PREVENT LOSS DURING SHIPPING

euro lt | HYBRIDS

Using Your Setup Instructions

The Euro LT Hybrids Setup Instructions are created specifically for your configuration. They are laid out sequentially in levels, including exploded views, and a logical series of detailed steps to assemble the main structure and components. We encourage you to study the instructions **before** attempting to assemble your exhibit.

Each page reminds you to tighten the setscrews after disassembling your exhibit to prevent loss of the locks and setscrews (see below in RED). This is VERY IMPORTANT.

Cleaning and Packing Your Display

- 1) Use care when cleaning aluminum extrusion or acrylic inserts. Use only non-abrasive cleaners.
- 2) When cleaning laminate inserts, countertops, or panels use mild cleansers and a soft material such as cotton.
- 3) Keep all display components away from extreme heat and long exposure to sunlight to avoid warping and fading.
- 4) Retain all packing material. It will make re-packing much easier and will reduce the likelihood of shipping damage.

General Setup Instructions for Extrusion System



Most exhibits can be assembled with the supplied Hex Key Tool. Occasionally, a flat head screwdriver may be required.



Most horizontal extrusion connections have a patented expandable lock. This lock inserts into the groove of an opposing extrusion. Tightening the lock with the Hex Key Tool expands the lock and creates a strong positive connection.

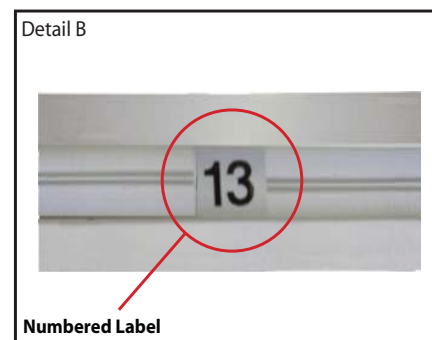

Each extrusion contains a numbered label which corresponds with setup instructions. The label is located within a groove of the extrusion (when possible). With extrusion components the labels contain Black numbers unless otherwise specified.

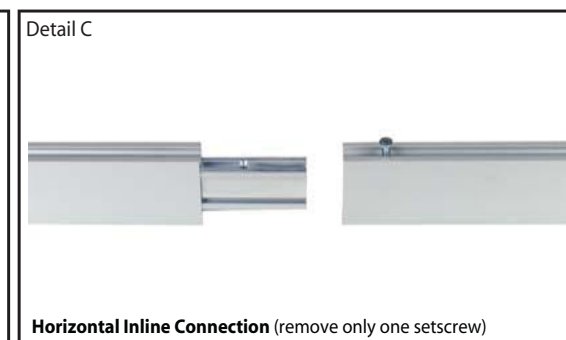

Remove only (1) setscrew when disassembling. Replace setscrew in extrusion after assembling it. Before packing, replace setscrew in extrusion to avoid losing it.

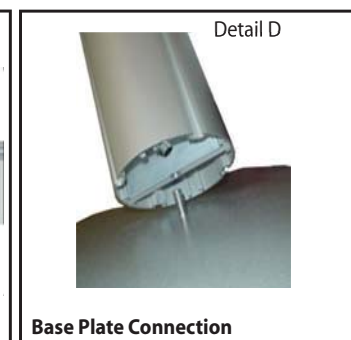

Attach base plate to round or square vertical extrusion using the bolt provided. Be careful not to strip the threads.

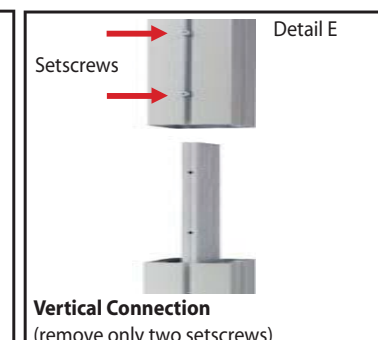

When vertical extrusions are packed in portable cases rather than crates or tubs, they must be broken down into smaller section which then require assembly.

Remove only (2) setscrews when disassembling. Replace setscrews in extrusion after assembling it. Before packing, replace setscrews in extrusion to avoid losing them.

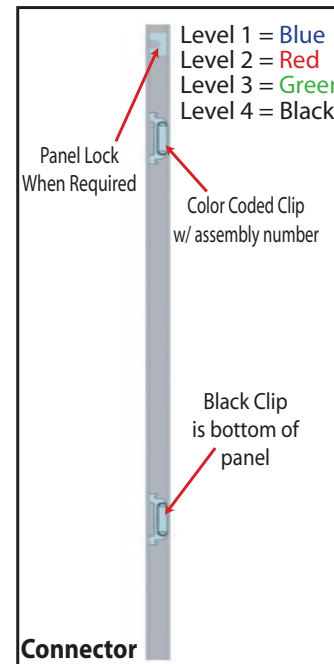

Each component has 2 clips, the lower clip is ALWAYS black. The top clip is color coded to distinguish which level. The color coded clip also contains the numbered label.

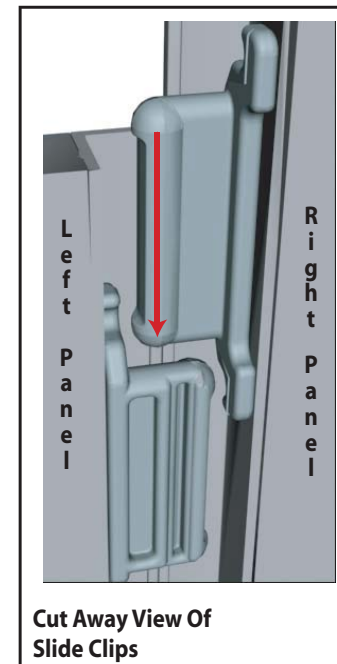

Components connect together by aligning them and sliding downward connecting clips together.

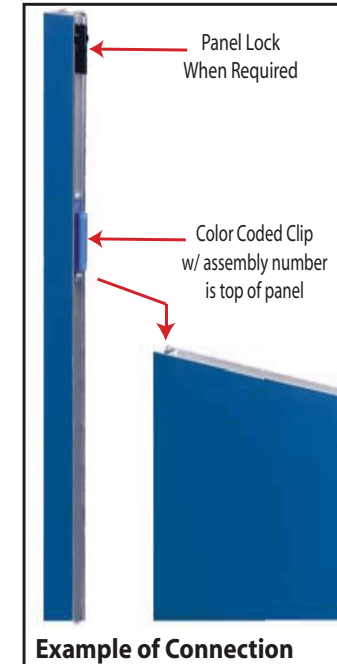

Configurations are assembled from left to right, usually starting with #1 and following the numbered sequence.

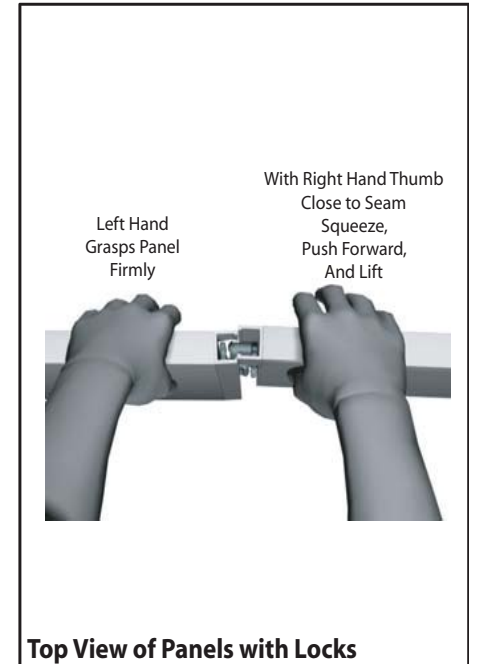

The first level of components contain panel locks that are located at the top of the panel for extra stability and seamless connection. When disassembling panels twist top connection slightly and lift right panel upward.

WHEN DISASSEMBLING ALUMINUM EXTRUSION, TIGHTEN ALL SETSCREWS AND LOCKS TO PREVENT LOSS DURING SHIPPING

866.652.2100

Part Number	Qty	Description
1	2	45"h Lower Vertical extrusion
2	1	45"h Upper Vertical extrusion
3	1	45"h Upper Vertical extrusion
4	1	48"h Lower Vertical extrusion
4A	1	48"h Lower Vertical extrusion w/ extrusion attachment
4B	1	48"h Lower Vertical extrusion w/ Door Hinges
4C	1	48"h Lower Vertical extrusion w/ holes for Counter Connection
5	1	48"h Upper Vertical extrusion w/ extrusion attachment
6	1	48"h Upper Vertical extrusion w/ extrusion attachment
7	1	48"h Upper Vertical extrusion
8	1	48"h Upper Vertical extrusion
9	6	12" Horizontal extrusion
10	3	24" Horizontal extrusion
10A	1	24" Horizontal extrusion
11	1	24" Horizontal extrusion w/ Velcro on back lower edge
11A	1	24" Horizontal extrusion w/ Velcro on back upper edge
12	2	44" Horizontal extrusion w/ Velcro on back lower edge/ 44" Horizontal extrusion w/ Velcro on back upper edge

Steps

- 1) Assemble vertical extrusions by connecting together extrusions [1 to 2, 1 to 3, 4A to 5, 4 to 6, 4C to 7 and 4B to 8].
- 2) Connect horizontal extrusions [9an 9A] between vertical extrusions [1/2, 1/3, 4C/7 and 4B/8] placing inserts as indicated.
- 3) Connect horizontal extrusions [10, 10A, 11 and 11A] between vertical extrusions [1/3, 4A/5, 4/6 and 4C/7] placing inserts as indicated.
- 4) Connect horizontal extrusions [12] between vertical extrusions [4A/5 and 4/6].

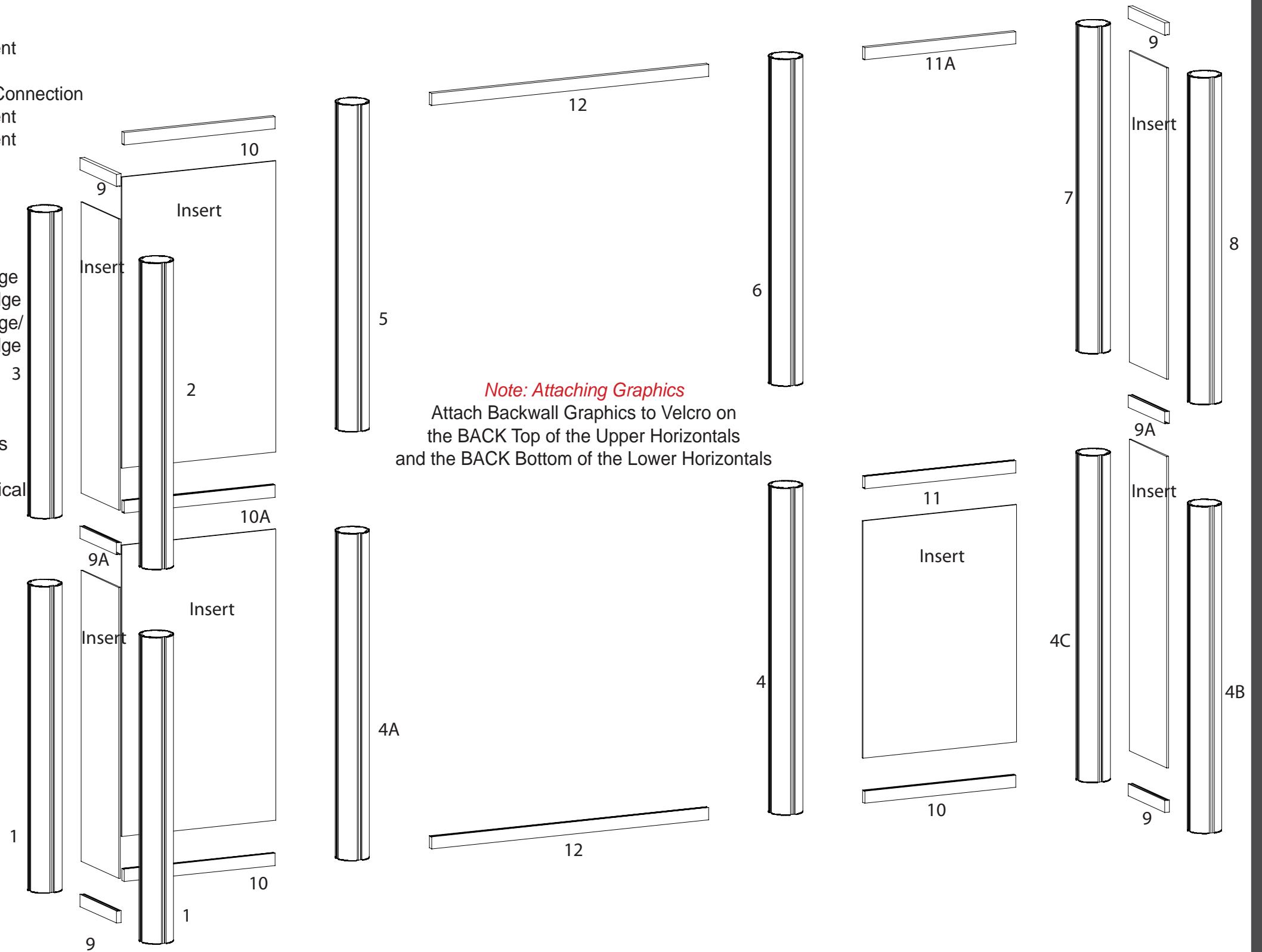

WHEN DISASSEMBLING ALUMINUM EXTRUSION, TIGHTEN ALL SETSCREWS AND LOCKS TO PREVENT LOSS DURING SHIPPING

866.652.2100

Part Number	Qty	Description
13	1	24" Horizontal extrusion w/ Velcro on back upper edge
14	1	24" Horizontal extrusion w/ Velcro on back lower edge
15	1	44" Horizontal extrusion w/ Velcro on back lower edge
16	1	44" Horizontal extrusion w/ Velcro on back upper edge
17	1	38"h Vertical extrusion
18	2	12" Horizontal extrusion
19	2	24" Horizontal extrusion

Note: Attaching Graphics
 Attach Backwall Graphics to Velcro on the BACK Top of the Upper Horizontals and the BACK Bottom of the Lower Horizontals

- Steps**
- 1) Connect horizontal extrusions [13 and 14] between vertical extrusions [1/2 and 4/5] (from previous page) as shown.
 - 2) Connect horizontal extrusions [15 and 16] between vertical extrusions [4/6 and 4/8] (from previous page) as shown.
 - 3) Connect horizontal extrusions [18] between vertical extrusions [4/6 and 17] placing insert as shown.
 - 4) Connect horizontal extrusions [19] between vertical extrusions [17 and 4/8] placing door as shown.

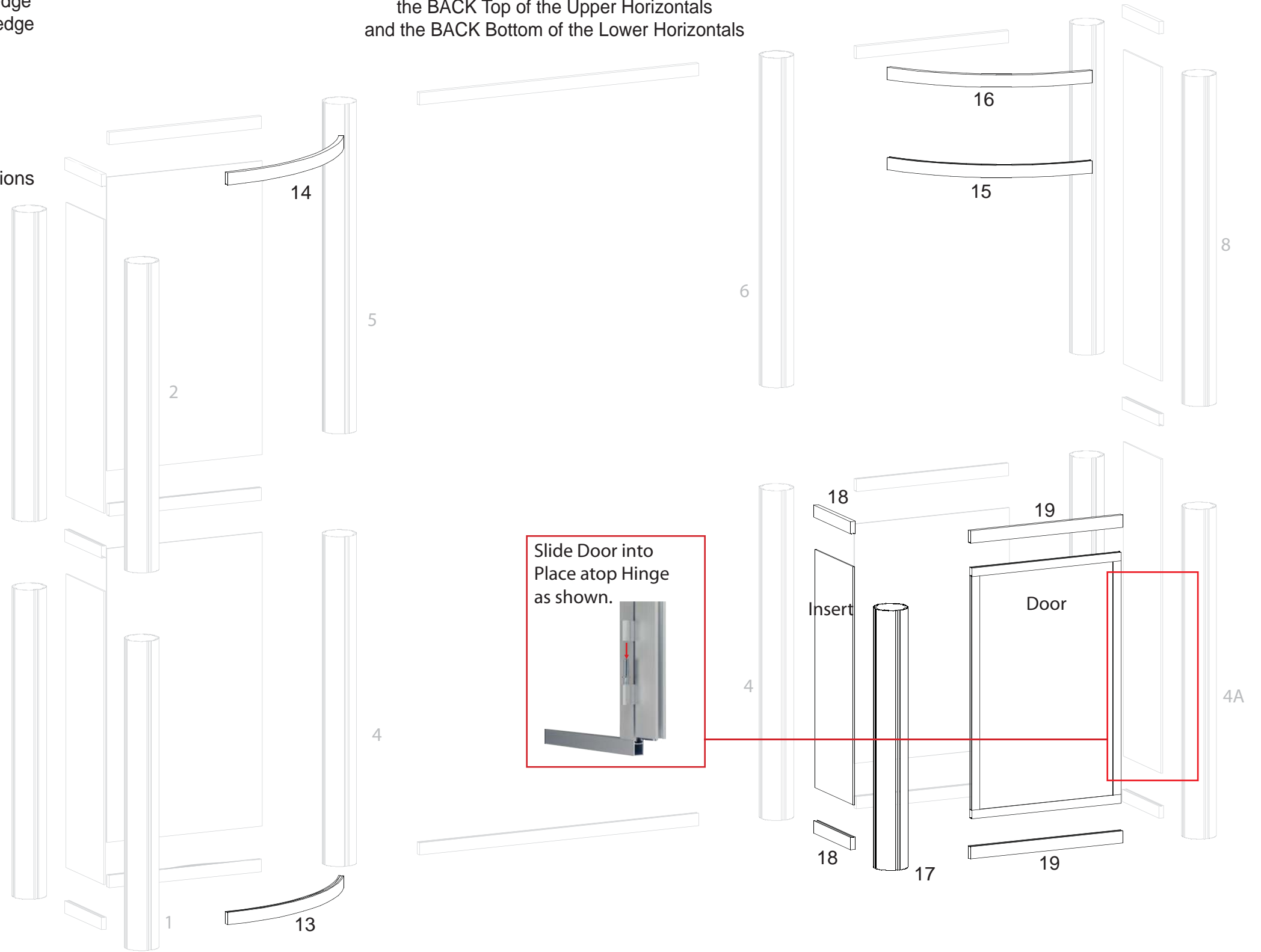

WHEN DISASSEMBLING ALUMINUM EXTRUSION, TIGHTEN ALL SETSCREWS AND LOCKS TO PREVENT LOSS DURING SHIPPING

866.652.2100

Wing Attachment

Slide A10 Clamp into groove of extrusion.



A10

When desired location is found, tighten set screw to secure.



Set-Screw

Tighten black plastic set screw to secure Wing in place.



Black Plastic Set-screw

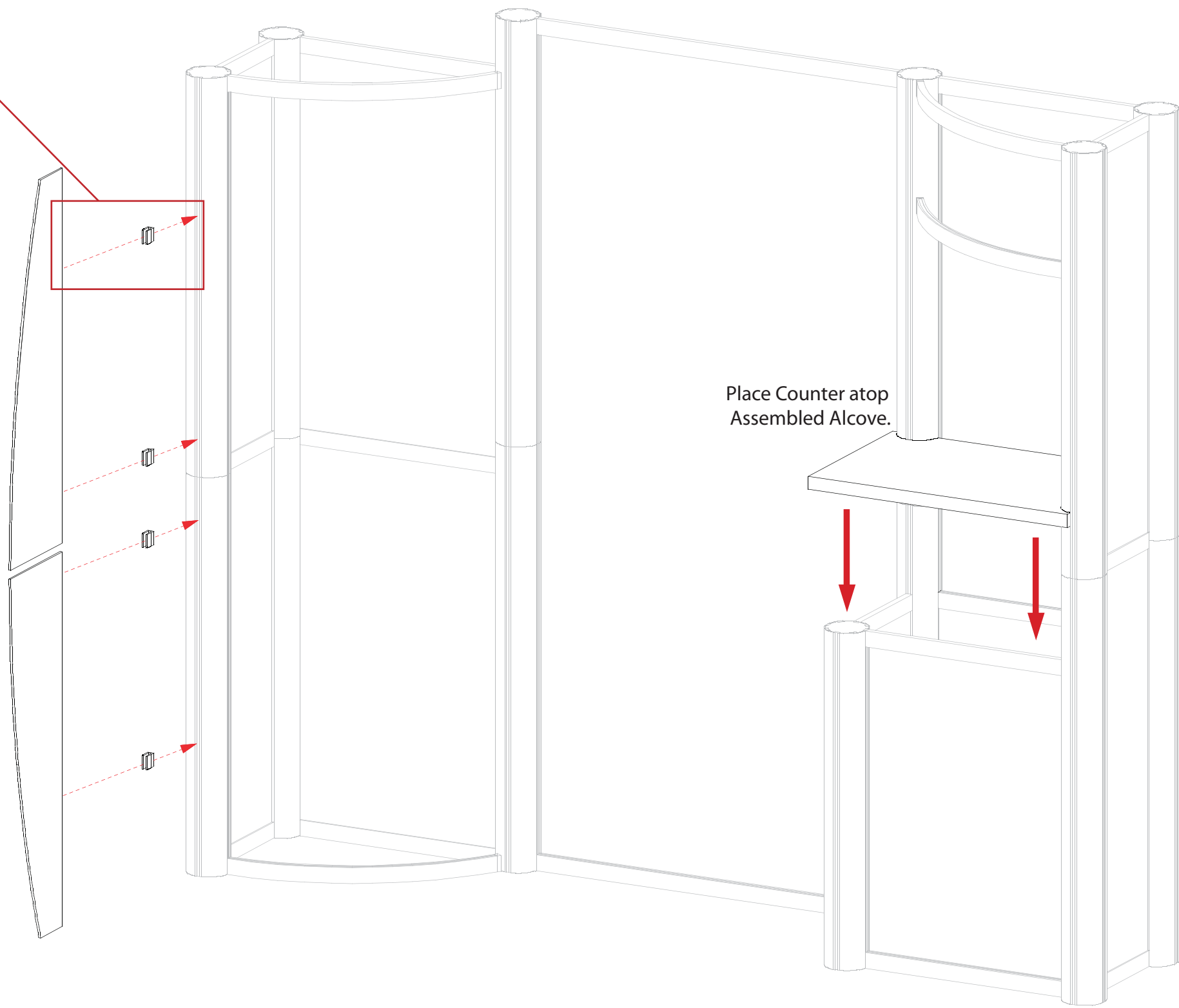

WHEN DISASSEMBLING ALUMINUM EXTRUSION, TIGHTEN ALL SETSCREWS AND LOCKS TO PREVENT LOSS DURING SHIPPING

866.652.2100

Item Number	Description
1	19"w x 38"h Flat Panel w/Door
2	19"w x 38"h Flat Panel w/Door
3	38"h 90° Connector
4	19"w x 38"h Flat Panel
5	38"h 90° Connector
6	19"w x 38"h Flat Panel
7	19"w x 38"h Flat Panel
8	38"h 90° Connector
9	19"w x 38"h Flat Panel
10	38"h 90° Connector
20	34.417" Horizontal extrusion
21	37.9188" Curved Vertical extrusion
22	34.417" Horizontal extrusion
23	37.9188" Curved Vertical extrusion

- Steps:
- 1) Connect panels together in numerical order as shown in illustrations.
 - 2) Connect extrusions [20 - 23] together, apply graphic and attach to assembled pedestal.
 - 3) Set counter atop assembled pedestal.

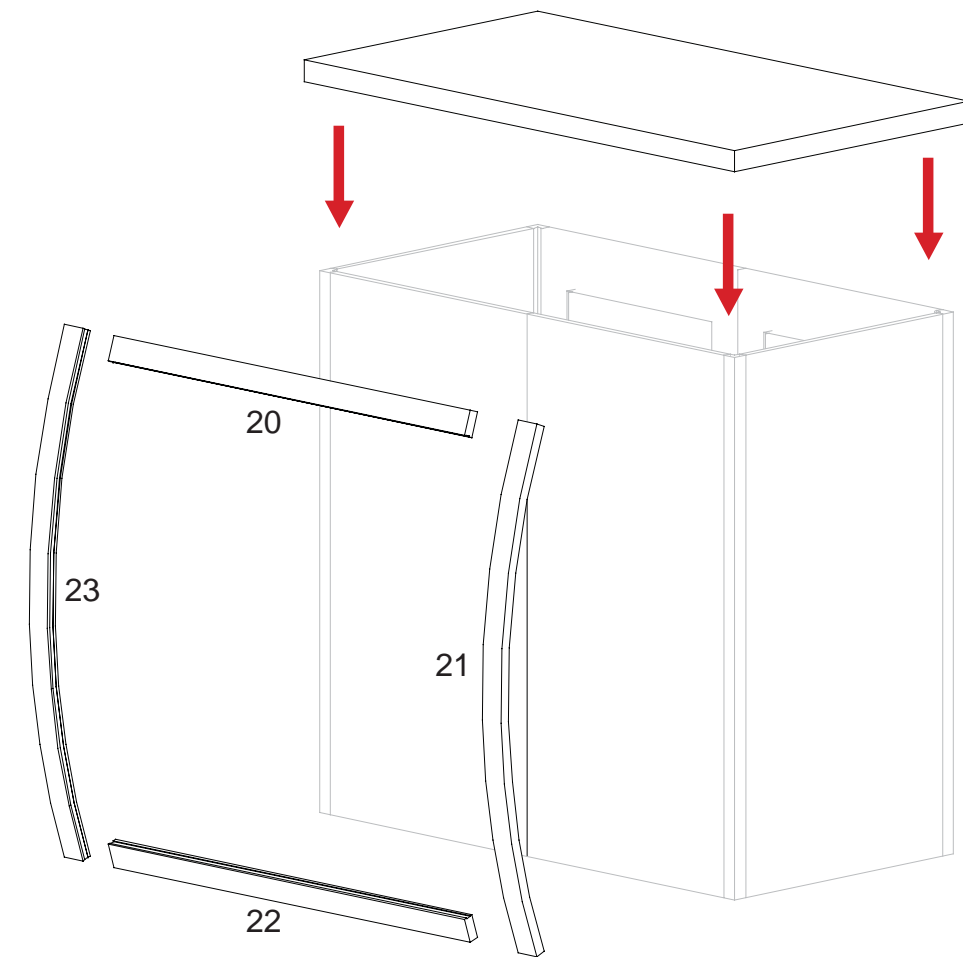
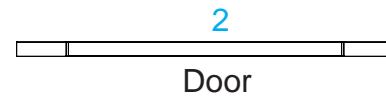
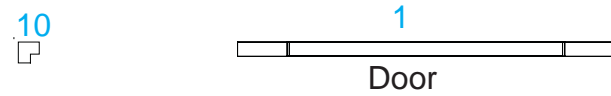
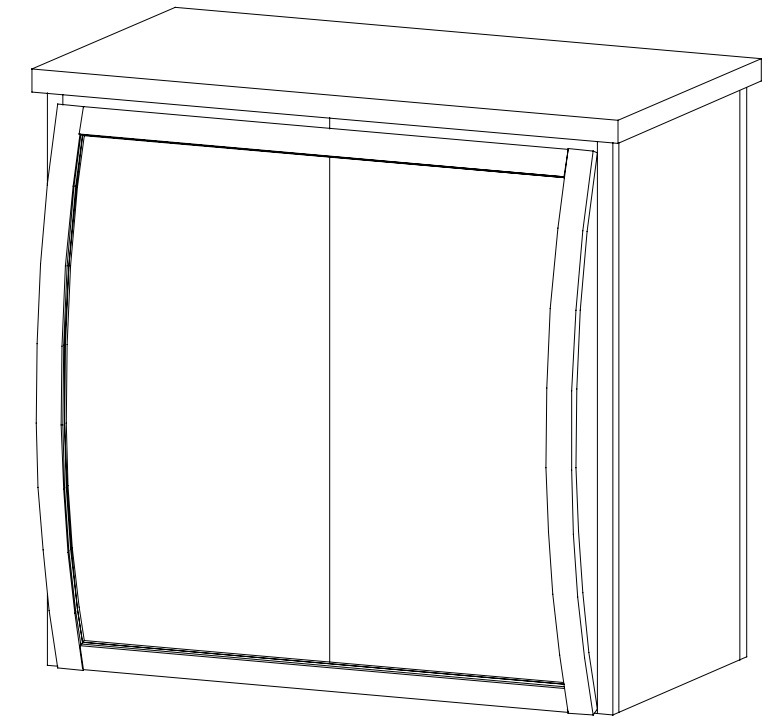

WHEN DISASSEMBLING ALUMINUM EXTRUSION, TIGHTEN ALL SETSCREWS AND LOCKS TO PREVENT LOSS DURING SHIPPING

NOTE :

PDF copies of your Setup Instructions are available @ classicexhibits.com
See the search tool on the lower left hand corner of the Home page.

Enter the 5 digit Order #.

Search for Setup Instructions

WHEN DISASSEMBLING ALUMINUM EXTRUSION, TIGHTEN ALL
SETSCREWS AND LOCKS TO PREVENT LOSS DURING SHIPPING