

# euro It | *HYBRIDS*

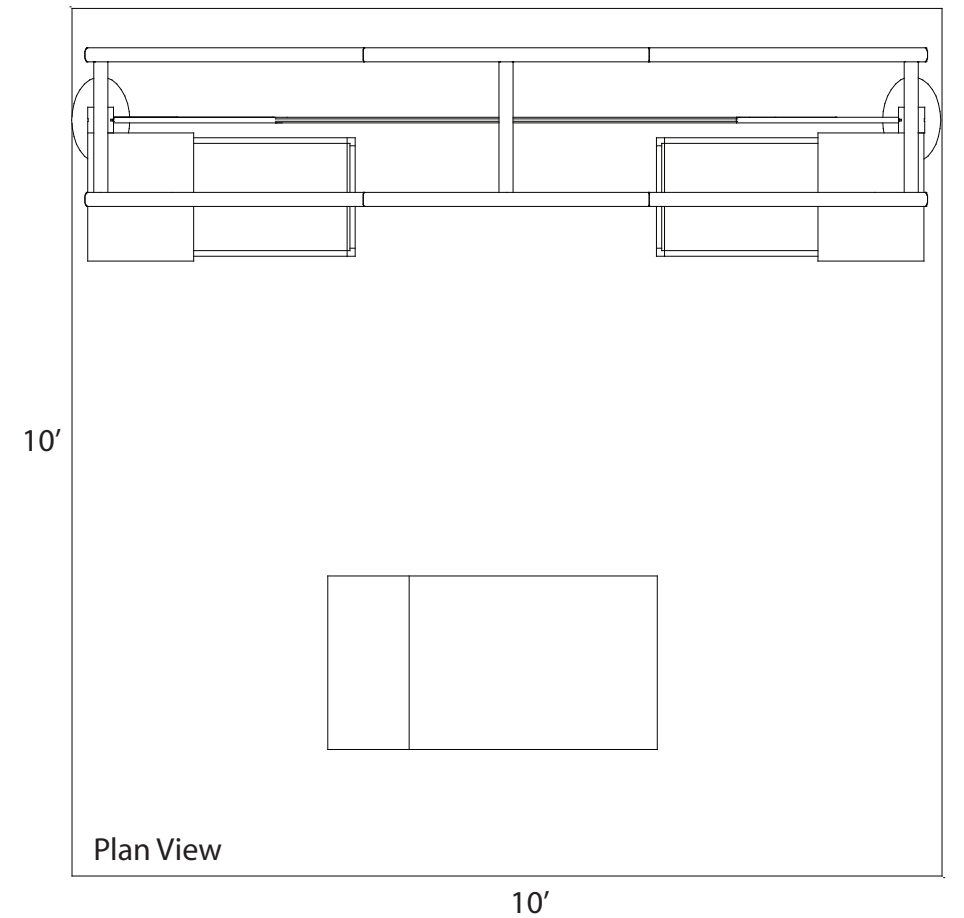
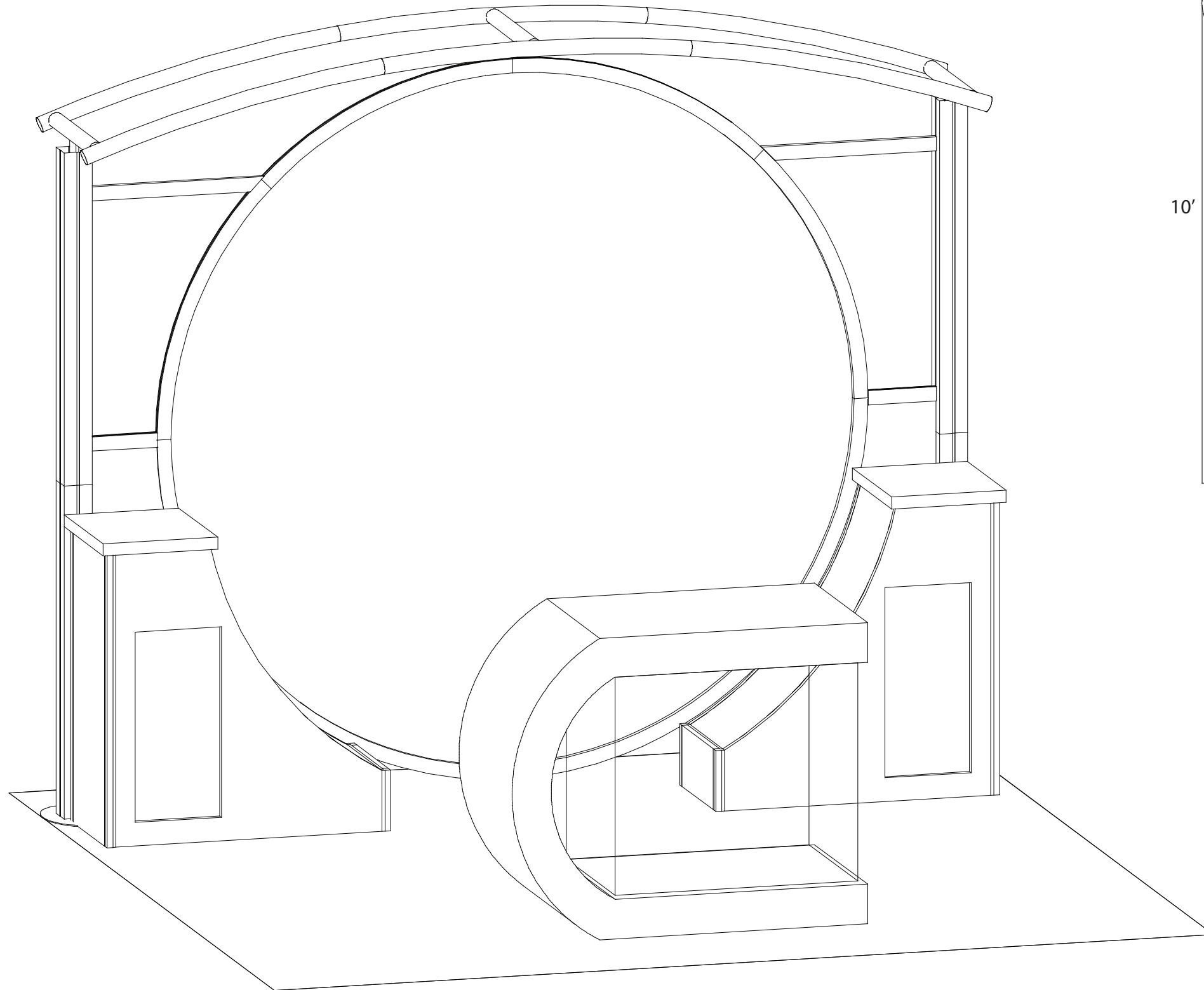

**WHEN DISASSEMBLING ALUMINUM EXTRUSION, TIGHTEN ALL SETSCREWS AND LOCKS TO PREVENT LOSS DURING SHIPPING**

# euro lt | HYBRIDS

## Using Your Setup Instructions

The Euro LT Hybrids Setup Instructions are created specifically for your configuration. They are laid out sequentially in levels, including exploded views, and a logical series of detailed steps to assemble the main structure and components. We encourage you to study the instructions **before** attempting to assemble your exhibit.

Each page reminds you to tighten the setscrews after disassembling your exhibit to prevent loss of the locks and setscrews (see below in RED). This is VERY IMPORTANT.

## Cleaning and Packing Your Display

- 1) Use care when cleaning aluminum extrusion or acrylic inserts. Use only non-abrasive cleaners.
- 2) When cleaning laminate inserts, countertops, or panels use mild cleansers and a soft material such as cotton.
- 3) Keep all display components away from extreme heat and long exposure to sunlight to avoid warping and fading.
- 4) Retain all packing material. It will make re-packing much easier and will reduce the likelihood of shipping damage.

## General Setup Instructions for Extrusion System



Most exhibits can be assembled with the supplied Hex Key Tool. Occasionally, a flat head screwdriver may be required.

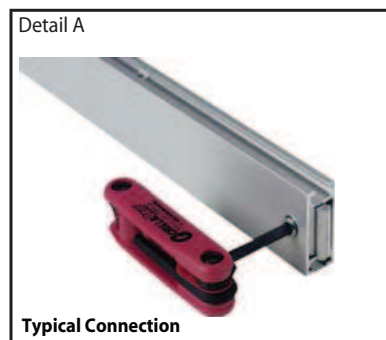

Most horizontal extrusion connections have a patented expandable lock. This lock inserts into the groove of an opposing extrusion. Tightening the lock with the Hex Key Tool expands the lock and creates a strong positive connection.

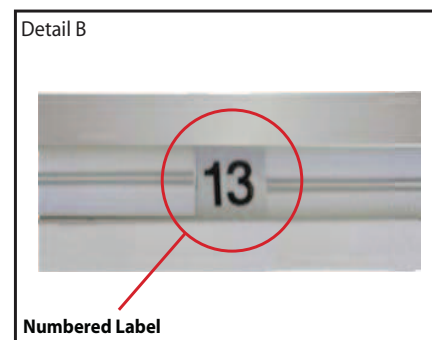
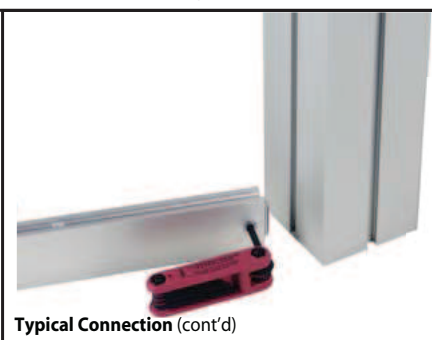

Each extrusion contains a numbered label which corresponds with setup instructions. The label is located within a groove of the extrusion (when possible). With extrusion components the labels contain Black numbers unless otherwise specified.

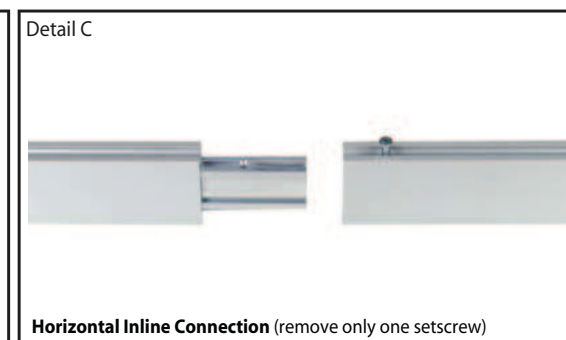

Remove only (1) setscrew when disassembling. Replace setscrew in extrusion after assembling it. Before packing, replace setscrew in extrusion to avoid losing it.

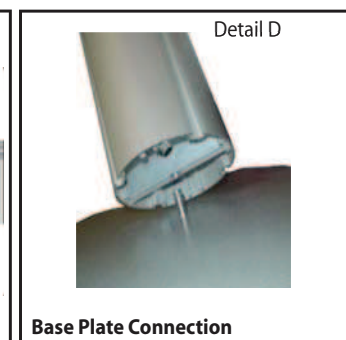

Attach base plate to round or square vertical extrusion using the bolt provided. Be careful not to strip the threads.

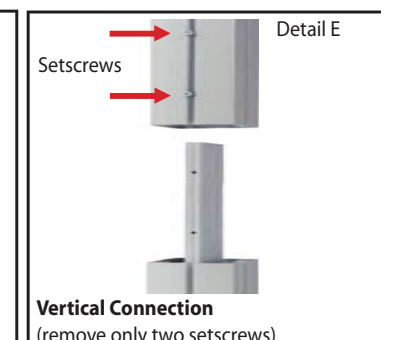

When vertical extrusions are packed in portable cases rather than crates or tubs, they must be broken down into smaller section which then require assembly.

Remove only (2) setscrews when disassembling. Replace setscrews in extrusion after assembling it. Before packing, replace setscrews in extrusion to avoid losing them.

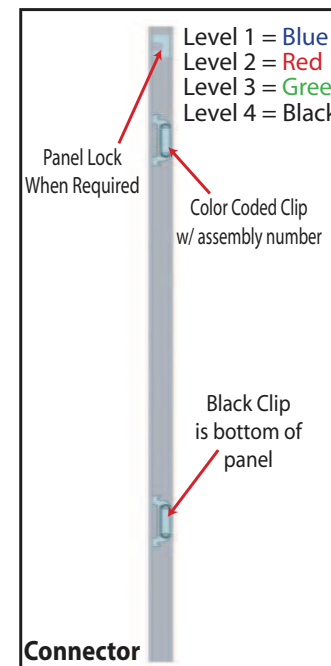

Each component has 2 clips, the lower clip is ALWAYS black. The top clip is color coded to distinguish which level. The color coded clip also contains the numbered label.

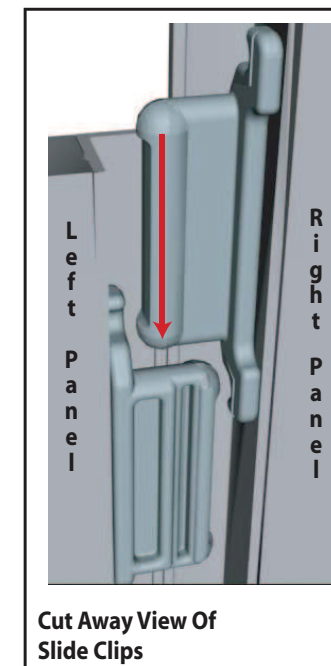

Components connect together by aligning them and sliding downward connecting clips together.

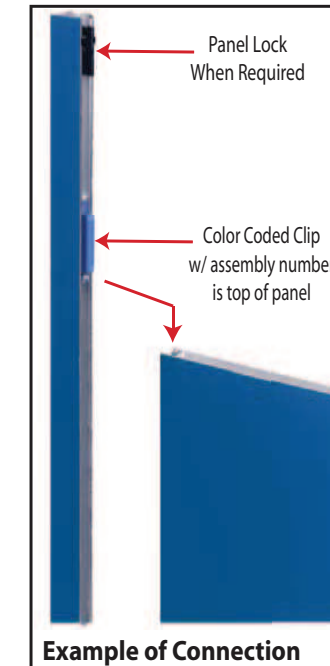

Configurations are assembled from left to right, usually starting with #1 and following the numbered sequence.

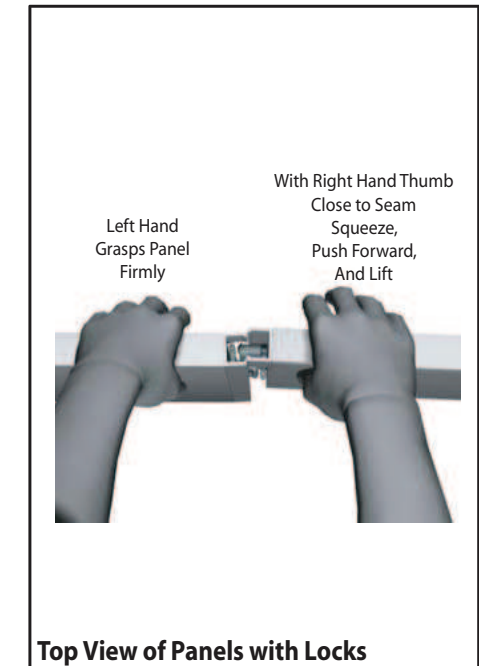

The first level of components contain panel locks that are located at the top of the panel for extra stability and seamless connection. When disassembling panels twist top connection slightly and lift right panel upward.

**WHEN DISASSEMBLING ALUMINUM EXTRUSION, TIGHTEN ALL SETSCREWS AND LOCKS TO PREVENT LOSS DURING SHIPPING**

866.652.2100

Item	Quantity	Description
1	2	Oval Base Plates
2	2	42" Square Vertical Extrusion
2A	2	42" Square Vertical Extrusion w/ Canopy Connection
3	1	20.115" Tapered Horizontal Extrusion
4	1	20.115" Tapered Horizontal Extrusion
5	1	7.322" Horizontal Extrusion
6	1	7.322" Horizontal Extrusion
7	1	47.1923" Curved Extrusion w/ Attached Velcro to Back of Extrusion
8	1	47.1923" Curved Extrusion w/ Attached Velcro to Back of Extrusion
9	1	47.1923" Curved Extrusion w/ Attached Velcro to Back of Extrusion
10	1	47.1923" Curved Extrusion w/ Attached Velcro to Back of Extrusion
11	1	47.1923" Curved Extrusion w/ Attached Velcro to Back of Extrusion
12	1	47.1923" Curved Extrusion w/ Attached Velcro to Back of Extrusion
13	1	20.115" Tapered Horizontal Extrusion
14	1	20.115" Tapered Horizontal Extrusion

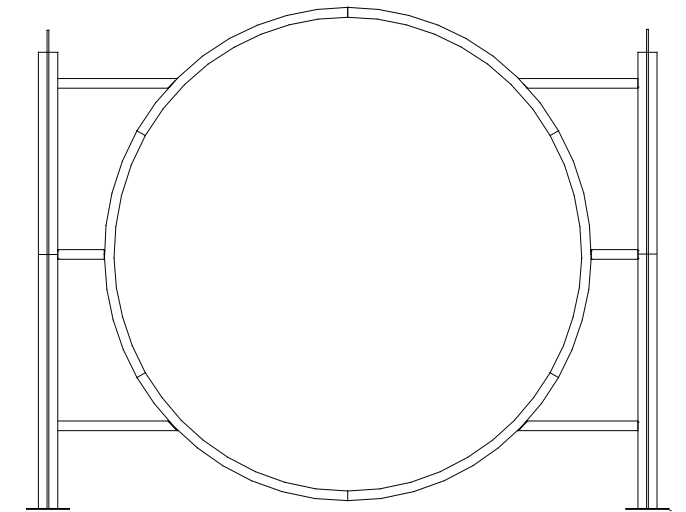

Steps:

- 1) Attach oval base plates [1] to vertical extrusions [2], connect vertical [2A] atop [2].
- 2) Attach tapered horizontal extrusions [3 and 4] to vertical extrusions [2].
- 3) Attach horizontal extrusions [5 and 6] to vertical extrusions [3], placing inserts between horizontal extrusions [3&5 and 4&6].
- 4) Assemble curved extrusion [7 and 8] together.
- 5) Attach each side of assembled curved extrusion to horizontal extrusions [3 and 4].
- 6) Attach curved extrusion [9] to top of curved extrusion [7] and to horizontal extrusion [5].
- 7) Attach curved extrusion [10] to top of curved extrusion [8] and to horizontal extrusion [6].
- 8) Attach curved extrusion [11] to top of curved extrusion [9].
- 9) Attach curved extrusion [12] between curved extrusions [11 and 10].
- 10) Attach tapered horizontal extrusion [13] between vertical extrusion [2] and curved extrusion [11], placing insert between horizontal extrusions [5 and 13].
- 11) Attach tapered horizontal extrusion [14] between vertical extrusion [2] and curved extrusion [12], placing insert between horizontal extrusions [6 and 14].
- 12) Attach graphic to Velcro on backside.

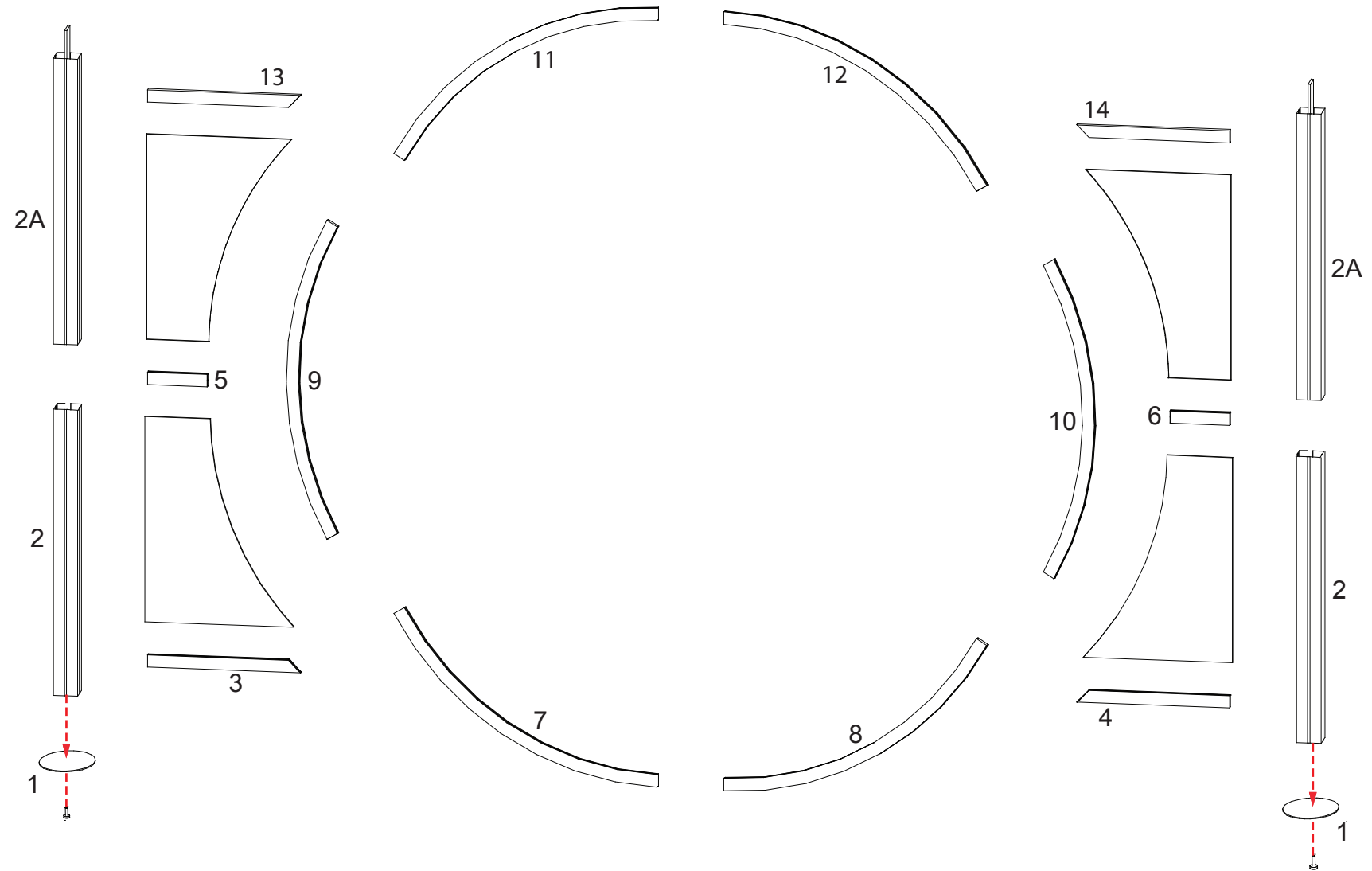

**WHEN DISASSEMBLING ALUMINUM EXTRUSION, TIGHTEN ALL SETSCREWS AND LOCKS TO PREVENT LOSS DURING SHIPPING**

866.652.2100

Item Number	Description	Item Number	Description
1	34" w x 38" h Custom Flat Panel	8	34" w x 38" h Custom Flat Panel
2	11" w x 9.5" h Flat Panel	9	38" h 90° Corner Connector
3	34" w x 38" h Custom Flat Panel w/ Door	10	11" w x 38" h Flat Panel
4	38" h 90° Corner Connector	11	38" h 90° Corner Connector
5	11" w x 38" h Flat Panel	12	34" w x 38" h Custom Flat Panel w/ Door
6	38" h 90° Corner Connector	13	11" w x 9.5" h Flat Panel
7	Custom Curved Panel	14	Custom Curved Panel

Steps:

Assemble panels in numerical order starting with #1. \*

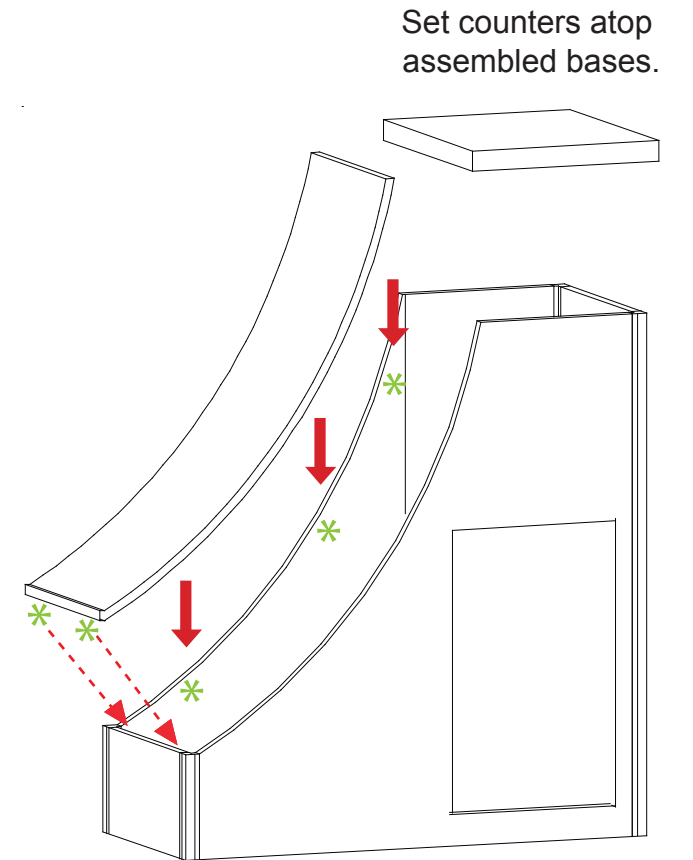
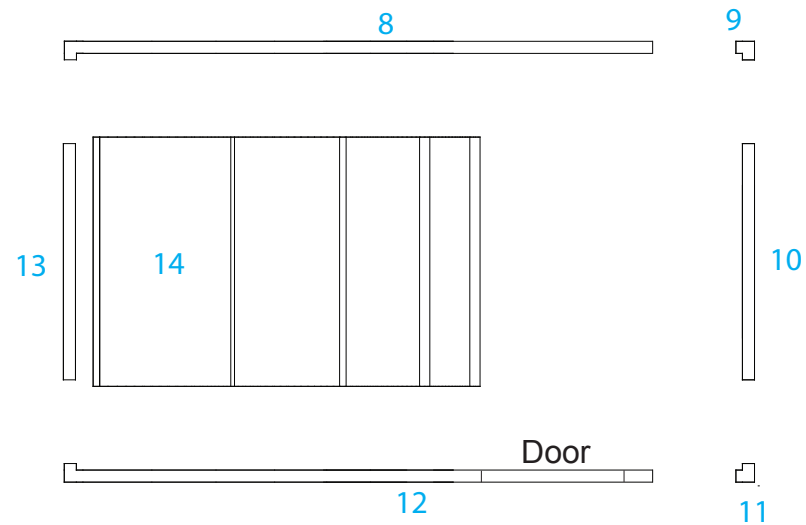
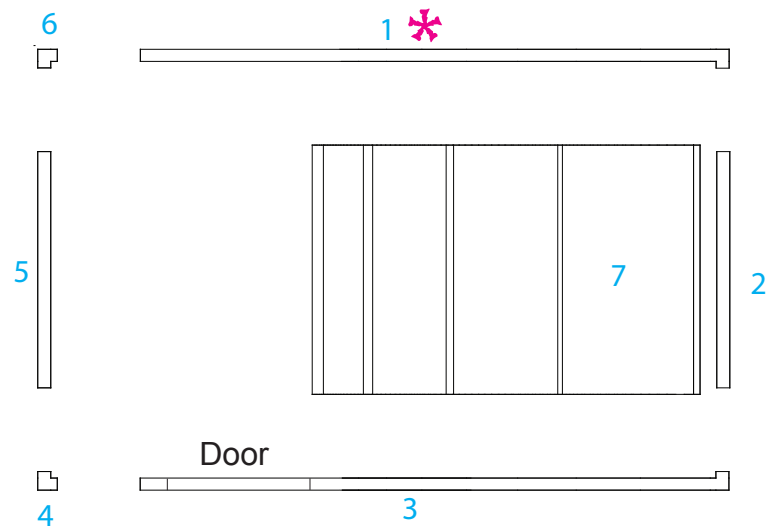
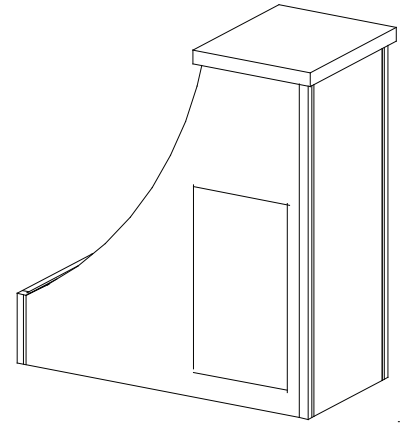
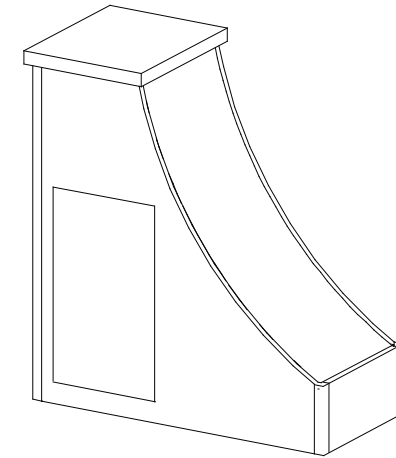

Place pins on lower end of curve panels [9 and 18] into groove of small panel and atop pins located inside panels.

\* = Pin Location

**WHEN DISASSEMBLING ALUMINUM EXTRUSION, TIGHTEN ALL SETSCREWS AND LOCKS TO PREVENT LOSS DURING SHIPPING**

866.652.2100

Item	Quantity	Description
A	1	39" Round formed extrusion
AB	1	39" Round formed extrusion
B	1	39" Round fomred extrusion
C	1	39" Round formed extrusion
CD	1	39" Round formed extrusion
D	1	39" Round formed extrusion
E	2	14" Round extrusion
F	1	14" Round extrusion

Steps:

- 1) Connect 39" (A) round formed extrusion to 39" (A) round formed extrusion.
- 2) Connect 39" (B) round formed extrusion to 39" (B) round formed extrusion.
- 3) Connect 39" (C) round formed extrusion to 39" (C) round formed extrusion.
- 4) Connect 39" (D) round formed extrusion to 39" (D) round formed extrusion.
- 5) Connect (A) round formed extrusion and (D) round formed extrusion to 14" (E) extrusion.
- 6) Connect (B) round formed extrusion and (C) round formed extrusion to 14" (E) extrusion.
- 7) Connect (AB) round formed extrusion and (CD) round formed extrusion to 14" (F) extrusion.
- 8) Attach Canopy Assembly to Vertical extrusions with Canopy attachments.

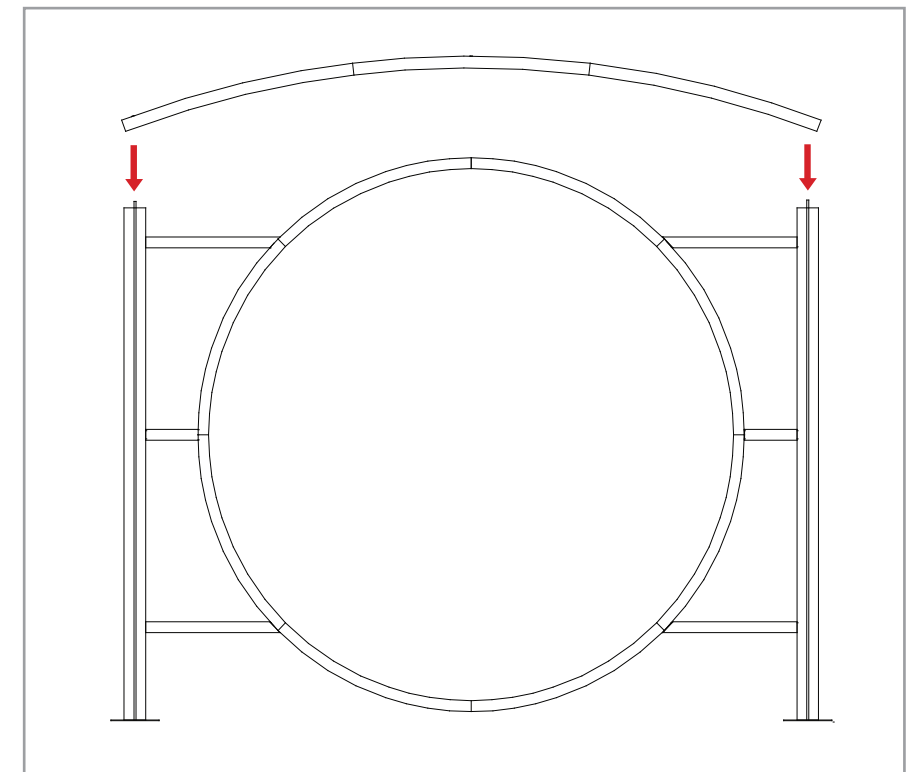
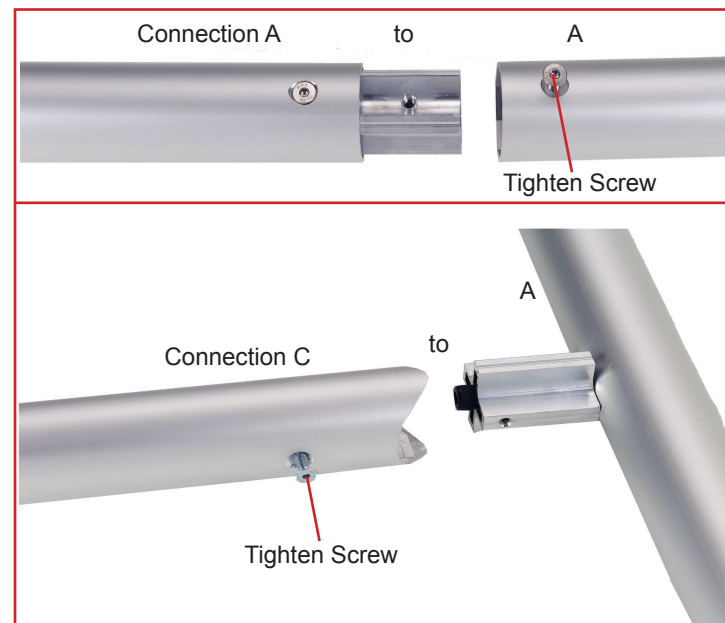
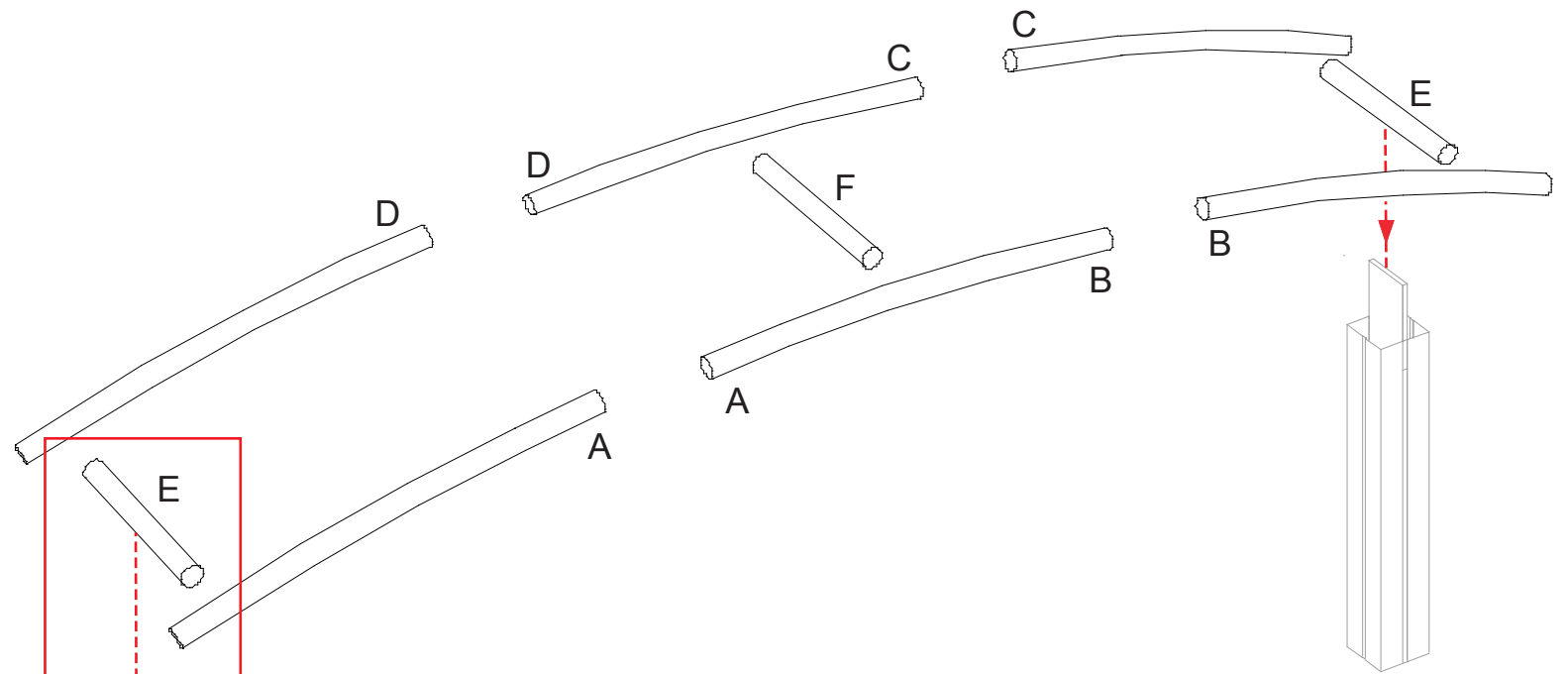

**WHEN DISASSEMBLING ALUMINUM EXTRUSION, TIGHTEN ALL SETSCREWS AND LOCKS TO PREVENT LOSS DURING SHIPPING**

866.652.2100

Workstation Packs Assembled.

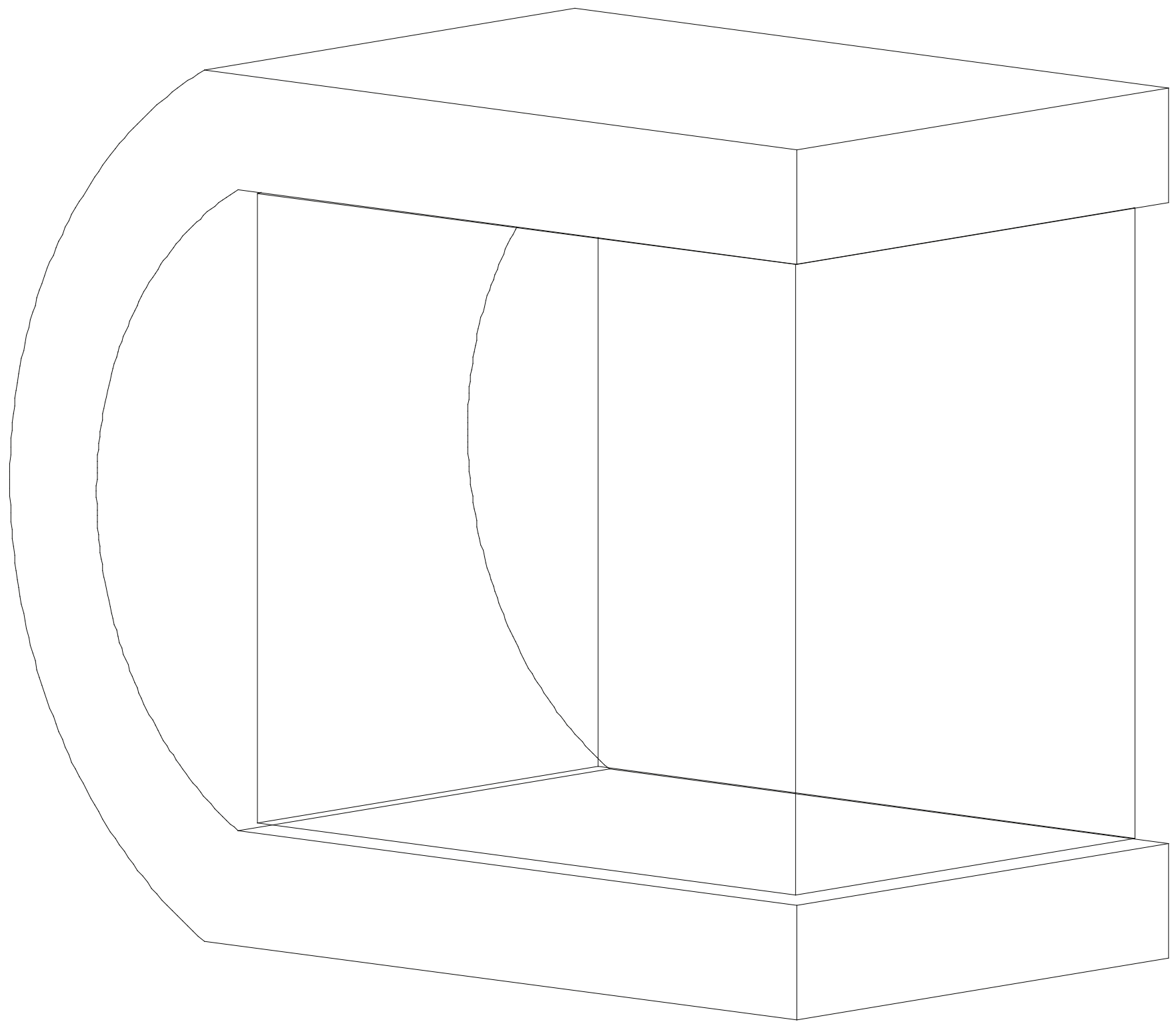

WHEN DISASSEMBLING ALUMINUM EXTRUSION, TIGHTEN ALL SETSCREWS AND LOCKS TO PREVENT LOSS DURING SHIPPING

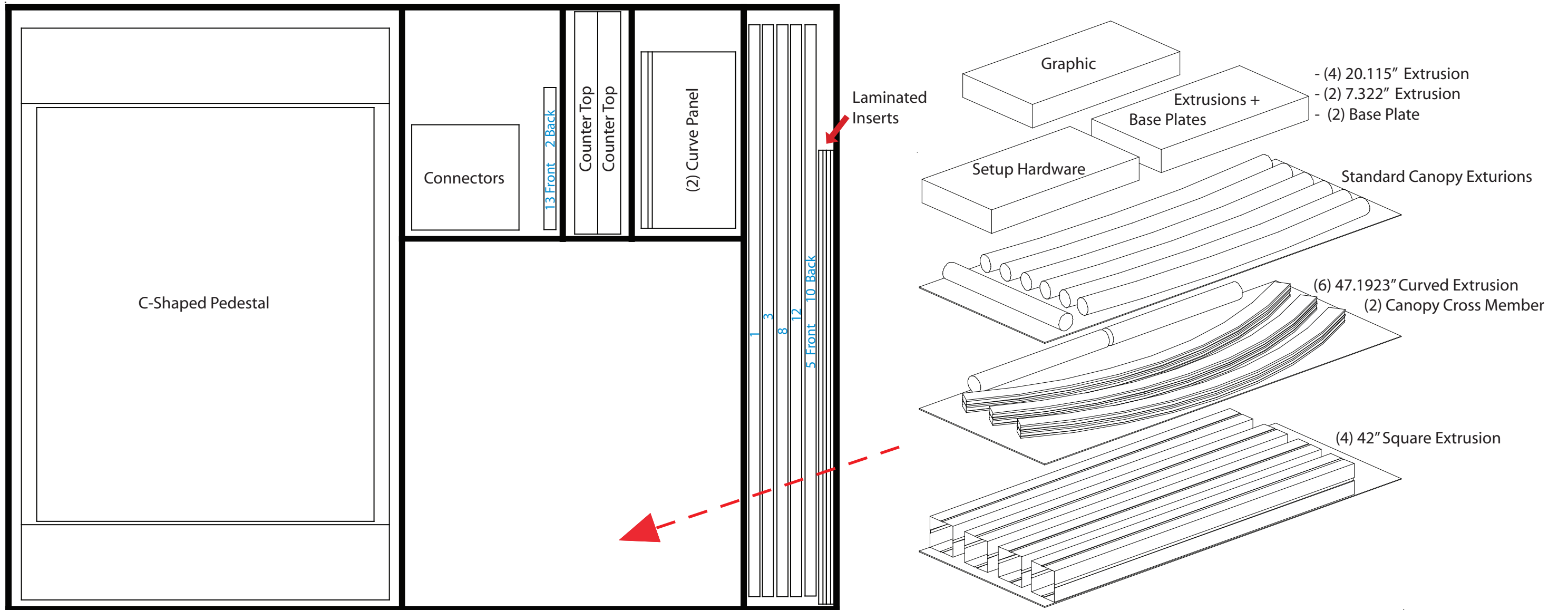

WHEN DISASSEMBLING ALUMINUM EXTRUSION, TIGHTEN ALL SETSCREWS AND LOCKS TO PREVENT LOSS DURING SHIPPING

866.652.2100



Crate Front View



Level 3

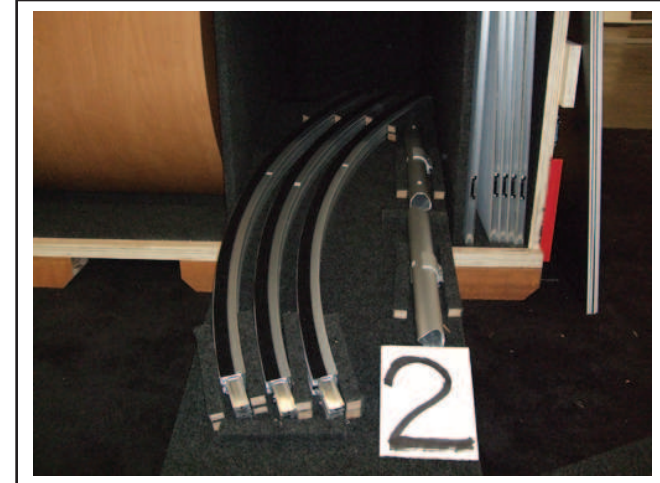

Level 2



Level 1

WHEN DISASSEMBLING ALUMINUM EXTRUSION, TIGHTEN ALL SETSCREWS AND LOCKS TO PREVENT LOSS DURING SHIPPING

**NOTE :**

PDF copies of your Setup Instructions are available @ [www.classicexhibits.com](http://www.classicexhibits.com)

Use the Search Tool located on the lower left-hand corner of the Classic Home

Enter your 5-7 digit Order #.

Search for Setup Instructions

WHEN DISASSEMBLING ALUMINUM EXTRUSION, TIGHTEN ALL  
SETSCREWS AND LOCKS TO PREVENT LOSS DURING SHIPPING