



NOTE :
 PDF copies of your Setup Instructions are available @ www.classicexhibits.com
 Use the Search Tool located on the lower left-hand corner of the Classic Home
 Enter your 5-7 digit Order #. Search for Setup Instructions

Item	Quantity	Description
1	1	38" h Round Vertical Extrusion
2	1	38" h Round Vertical Extrusion
3	1	38" h Round Vertical Extrusion w/ Hinges
4	1	38" h Round Vertical Extrusion w/ Door Stopper
5	2	33" Curved Horizontal Extrusion
6	2	12" Horizontal Extrusion
7	2	9.215" Horizontal Extrusion
8	2	12" Horizontal Extrusion
9	1	34.418" Vertical Extrusion

Steps:

- 1) Attach lower horizontal extrusions [5, 6, 7 and 8] between vertical extrusions [1, 2, 3 and 4].
- 2) Attach vertical extrusion [9] to horizontal extrusion [5], leave loose, placing inserts as indicated, then tighten setscrews to secure vertical in place.
- 3) Place remaining inserts and door in place.
- 4) Attach upper horizontal extrusions [5, 6, 7 and 8] between vertical extrusions [1, 2, 3 and 4].
- 5) Velcro internal shelf supports to inside assembled pedestal
- 6) Set internal shelf atop shelf supports
- 7) Set counter top on assembled pedestal.
- 8) Attach plex shelf to counter top using stand-offs.

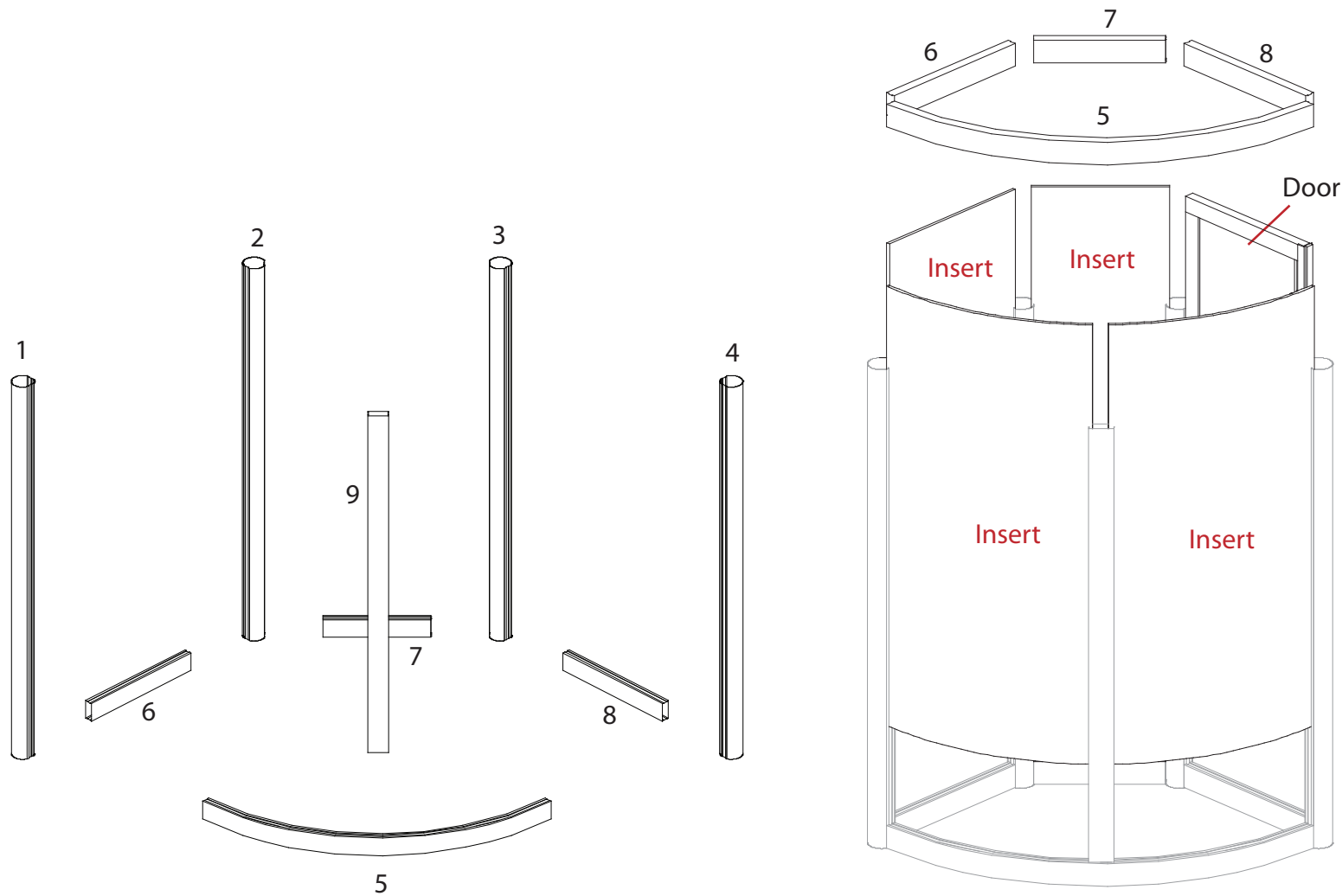
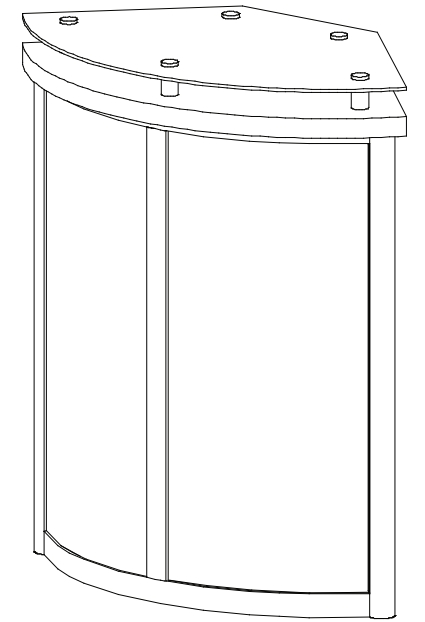

Door Attachment
 Slide Door into
 Place atop Hinge
 as shown.

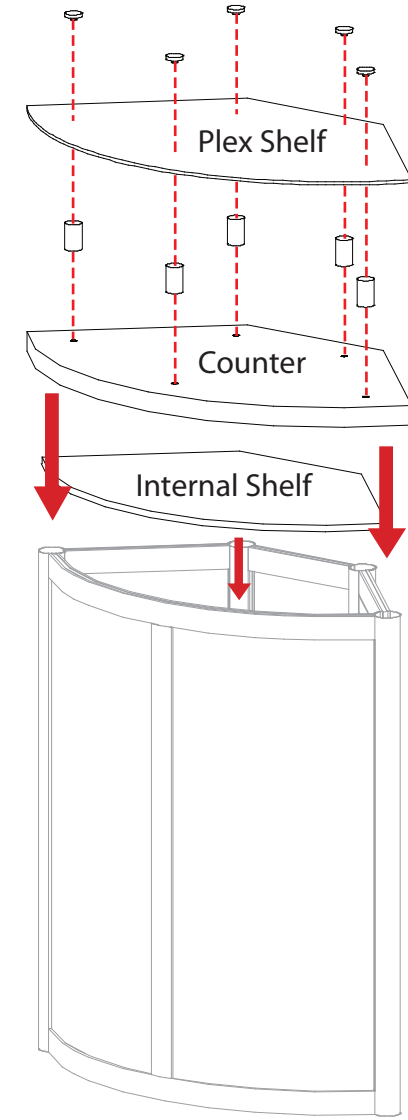

Place counter atop assembled pedestal base. Attach top shelf to counter using stand-offs.

WHEN DISASSEMBLING ALUMINUM EXTRUSION, TIGHTEN ALL SETSCREWS AND LOCKS TO PREVENT LOSS DURING SHIPPING

visionary™ IDESIGNS

Using Your Setup Instructions

The Visionary Designs Setup Instructions are created specifically for your configuration. They are laid out sequentially, including an exploded view of the entire display, and then a logical series of detailed steps to assemble the main structure and components. We encourage you to study the instructions **before** attempting to assemble your exhibit.

Each page reminds you to tighten the setscrews after disassembling your exhibit to prevent loss of the locks and setscrews (see below in RED). This is **VERY IMPORTANT**.

Cleaning and Packing Your Display

- 1) Use care when cleaning aluminum extrusion or acrylic inserts. Use only non-abrasive cleaners.
- 2) When cleaning laminate inserts or countertops, use mild cleansers and a soft material such as cotton.
- 3) Keep all display components away from extreme heat and long exposure to sunlight to avoid warping and fading.
- 4) Retain all packing material. It will make re-packing much easier and will reduce the likelihood of shipping damage.



The Tool

Most Visionary Designs exhibits can be assembled with the supplied Hex Key Tool. Occasionally, a flat head screwdriver may be required.

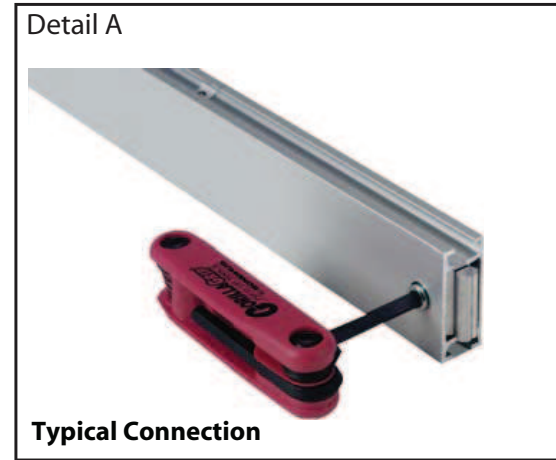

Detail A

Typical Connection



Typical Connection (cont'd)

Most horizontal extrusion connections have a patented expandable lock. This lock inserts into the groove of an opposing extrusion. Tightening the lock with the Hex Key Tool expands the lock and creates a strong positive connection.

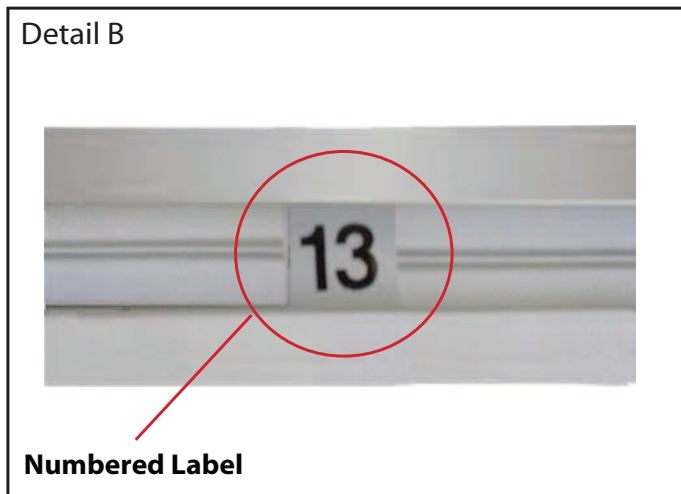

Detail B

Numbered Label

Each extrusion contains a numbered label which corresponds with setup instructions. The label is located within a groove of the extrusion (when possible). With Visionary Designs the labels contain Black numbers unless otherwise specified.



Detail C

Horizontal Inline Connection (remove only one setscrew)

Remove only (1) setscrew when disassembling. Replace setscrew in extrusion after assembling it. Before packing, replace setscrew in extrusion to avoid losing it.

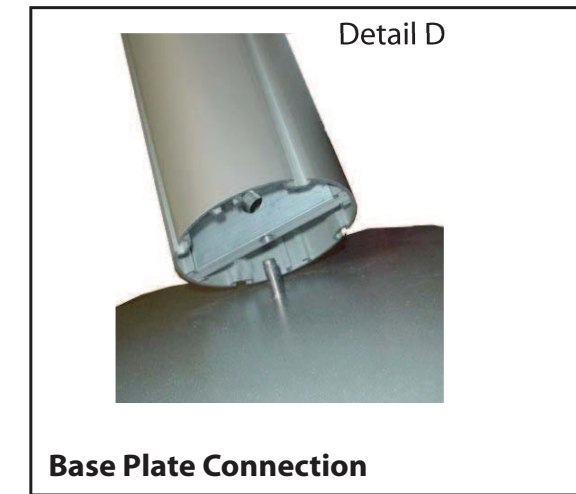

Detail D

Base Plate Connection

Attach base plate to round or square vertical extrusion using the bolt provided. Be careful not to strip the threads.

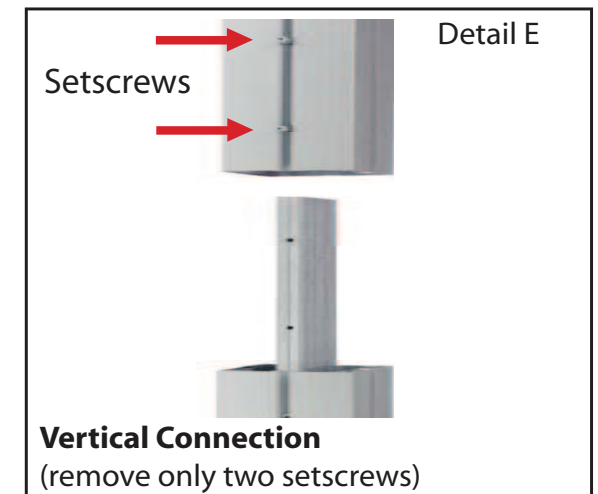

Detail E

Vertical Connection
(remove only two setscrews)

When vertical extrusions are packed in portable cases rather than crates or tubs, they must be broken down into smaller sections which then require assembly.

Remove only (2) setscrews when disassembling. Replace setscrews in extrusion after assembling it. Before packing, replace setscrews in extrusion to avoid losing them.

WHEN DISASSEMBLING ALUMINUM EXTRUSION, TIGHTEN ALL SETSCREWS AND LOCKS TO PREVENT LOSS DURING SHIPPING

866.652.2100

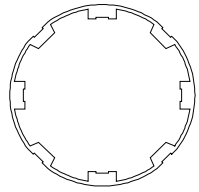

38"H Round Extrusion
Qty. : 4

34.418"H Extrusion
Qty. : 1



12"W Extrusion
Qty. : 4

9.215"W Extrusion
Qty. : 2

33"W Curved Extrusion
Qty. : 2



Shelf Support
Qty. : 4

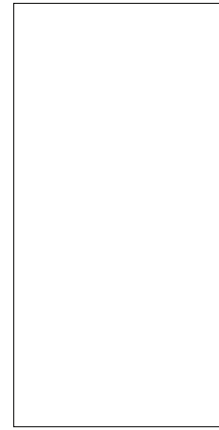

16.042"W x 34.855"H
Laminated Insert
Qty. : 2



12.4375"W x 34.855"H
Laminated Insert
Qty. : 1

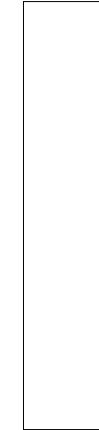

9.6525"W x 34.855"H
Laminated Insert
Qty. : 1

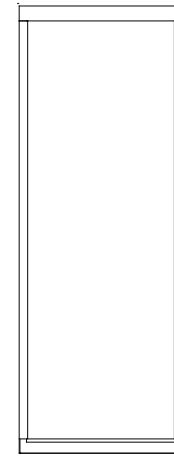

Locking Door
Qty. : 1

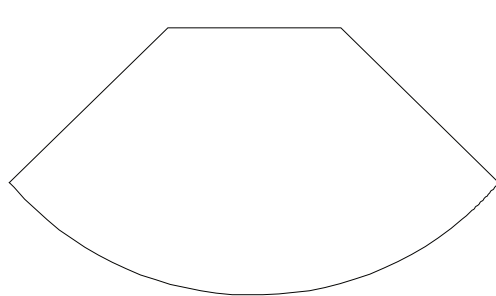

Internal Shelf
Qty. : 1

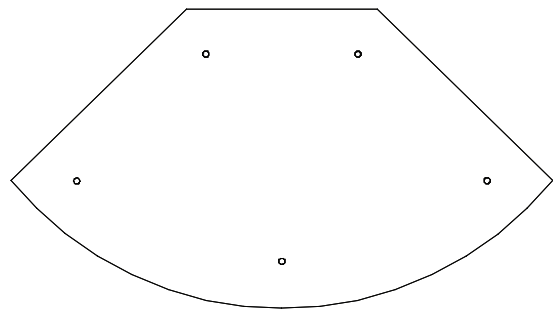

Counter Top
Qty. : 1

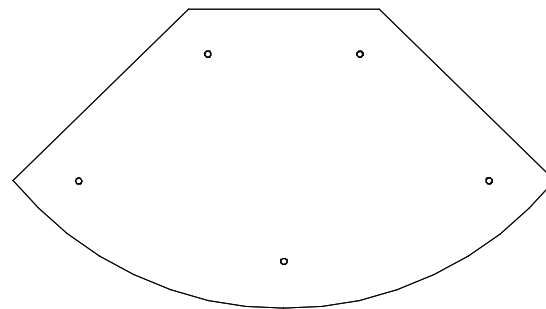

Plex Shelf
Qty. : 1

Additional Accessories:

Setup Hardware

WHEN DISASSEMBLING ALUMINUM EXTRUSION, TIGHTEN ALL SETSCREWS AND LOCKS TO PREVENT LOSS DURING SHIPPING

euro It | HYBRIDS

NOTE :
 PDF copies of your Setup Instructions are available @ www.classicexhibits.com
 Use the Search Tool located on the lower left-hand corner of the Classic Home page.
 Enter your 5-7 digit Order #.

Search for Setup Instructions

Item Number	Description
1	14.125"w x 38"h Panel
2	38"h Flexible Connector
3	23"w x 38"h Panel w/ Door
4	8.003"w x 38"h Panel
5	38"h Flexible Connector
6	14.125"w x 38"h Panel
7	38"h 90° Connector
8	57.5°r Curved Panel
9	57.5°r Curved Panel
10	38"h 90° Connector

- Steps:
- 1) Assemble by starting at panel #1 and continue in numerical order.
 - 2) Velcro internal shelf supports to inside of assembled base.
 - 3) Set internal shelf atop shelf supports.
 - 4) Place counter atop assembled pedestal base.
 - 5) Attach top shelf to counter using stand-offs.

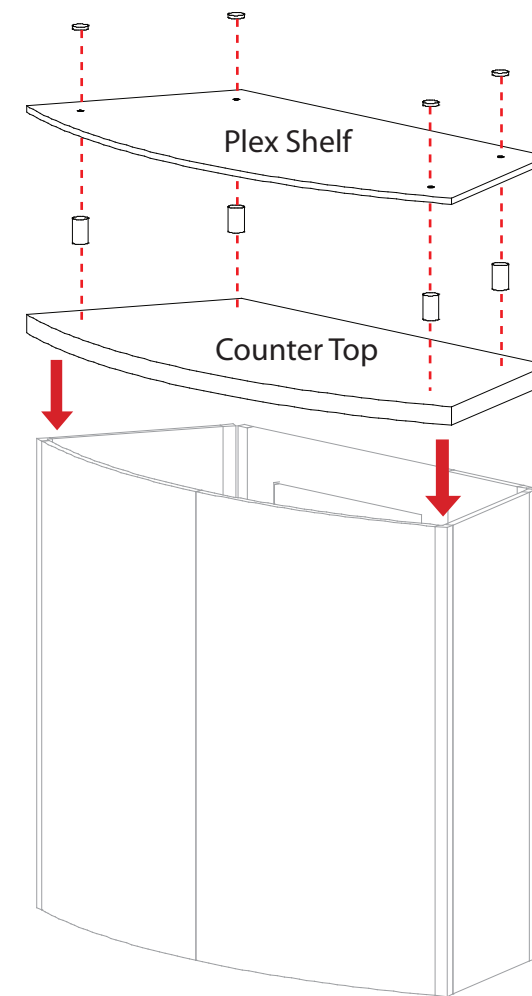
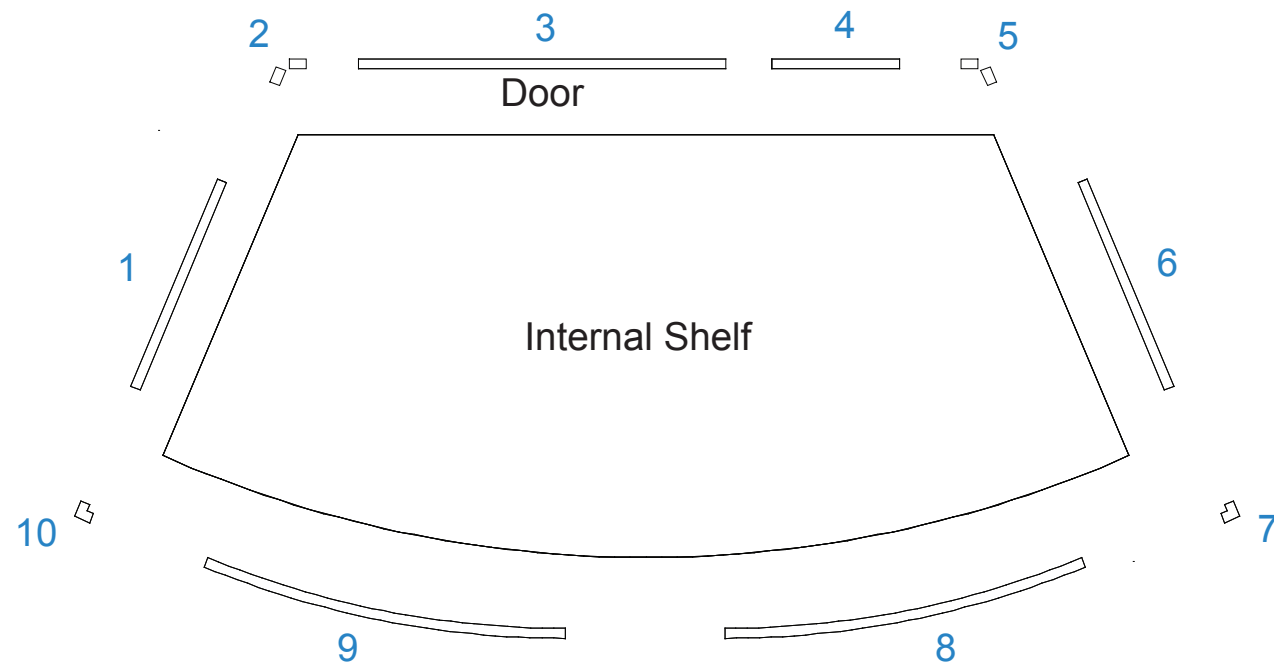
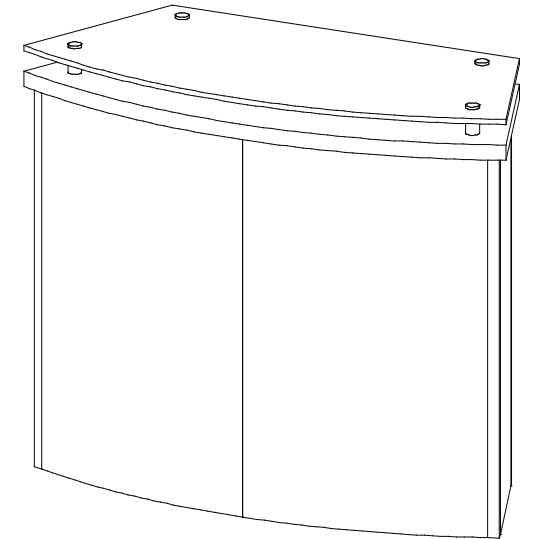

Place counter atop assembled pedestal base. Attach top shelf to counter using stand-offs.

WHEN DISASSEMBLING ALUMINUM EXTRUSION, TIGHTEN ALL SETSCREWS AND LOCKS TO PREVENT LOSS DURING SHIPPING

euro lt | HYBRIDS

Using Your Setup Instructions

The Euro LT Hybrids Setup Instructions are created specifically for your configuration. They are laid out sequentially in levels, including exploded views, and a logical series of detailed steps to assemble the main structure and components. We encourage you to study the instructions **before** attempting to assemble your exhibit.

Each page reminds you to tighten the setscrews after disassembling your exhibit to prevent loss of the locks and setscrews (see below in RED). This is VERY IMPORTANT.

Cleaning and Packing Your Display

- 1) Use care when cleaning aluminum extrusion or acrylic inserts. Use only non-abrasive cleaners.
- 2) When cleaning laminate inserts, countertops, or panels use mild cleansers and a soft material such as cotton.
- 3) Keep all display components away from extreme heat and long exposure to sunlight to avoid warping and fading.
- 4) Retain all packing material. It will make re-packing much easier and will reduce the likelihood of shipping damage.

General Setup Instructions for Extrusion System



Most exhibits can be assembled with the supplied Hex Key Tool. Occasionally, a flat head screwdriver may be required.

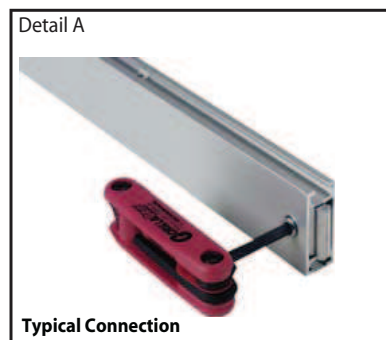

Most horizontal extrusion connections have a patented expandable lock. This lock inserts into the groove of an opposing extrusion. Tightening the lock with the Hex Key Tool expands the lock and creates a strong positive connection.

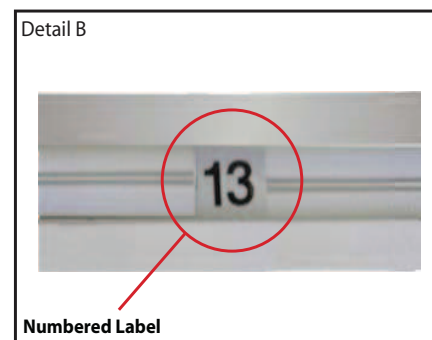

Each extrusion contains a numbered label which corresponds with setup instructions. The label is located within a groove of the extrusion (when possible). With extrusion components the labels contain Black numbers unless otherwise specified.

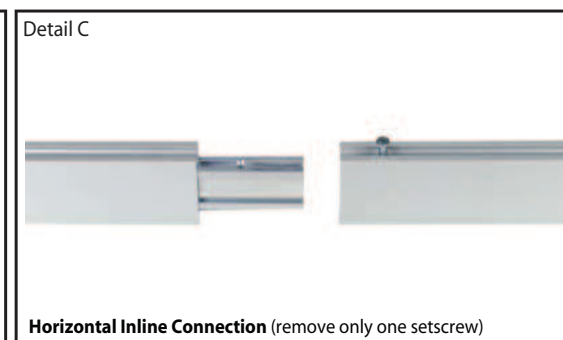

Remove only (1) setscrew when disassembling. Replace setscrew in extrusion after assembling it. Before packing, replace setscrew in extrusion to avoid losing it.

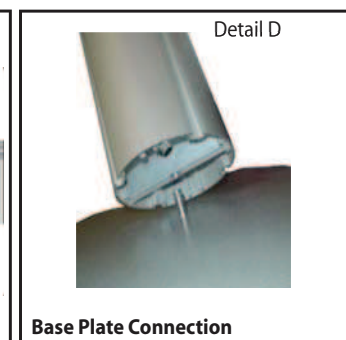

Attach base plate to round or square vertical extrusion using the bolt provided. Be careful not to strip the threads.

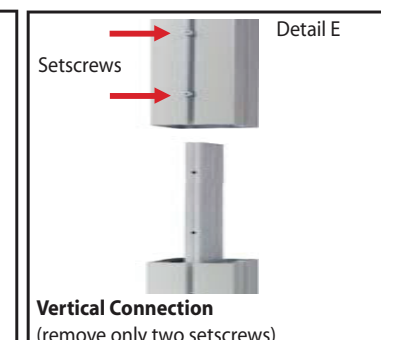

When vertical extrusions are packed in portable cases rather than crates or tubs, they must be broken down into smaller section which then require assembly.

Remove only (2) setscrews when disassembling. Replace setscrews in extrusion after assembling it. Before packing, replace setscrews in extrusion to avoid losing them.

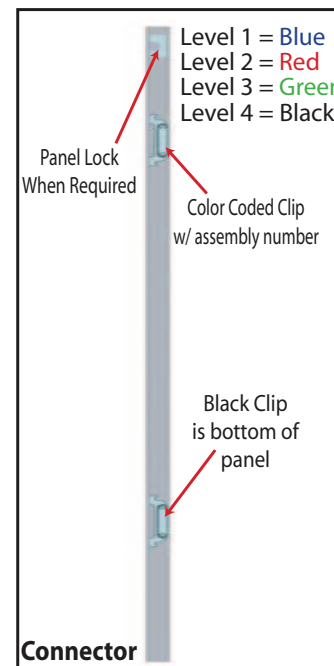

Each component has 2 clips, the lower clip is ALWAYS black. The top clip is color coded to distinguish which level. The color coded clip also contains the numbered label.

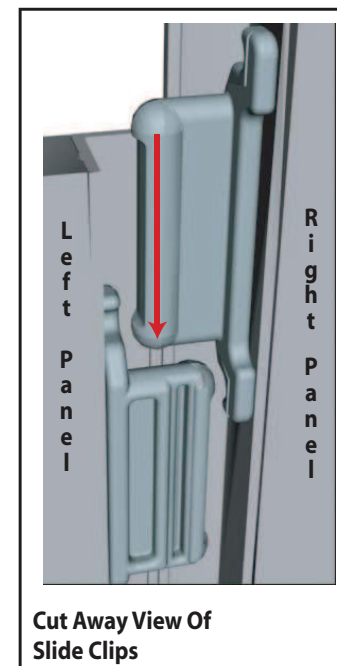

Components connect together by aligning them and sliding downward connecting clips together.

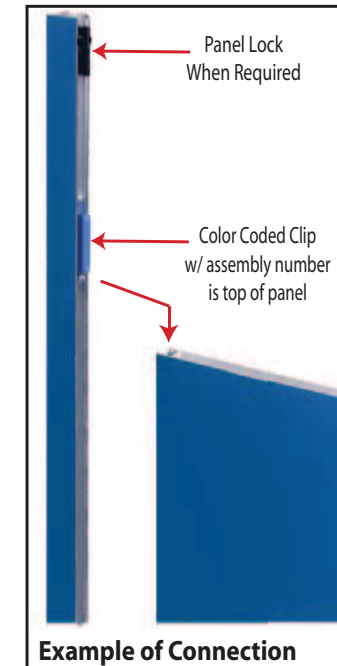

Configurations are assembled from left to right, usually starting with #1 and following the numbered sequence.

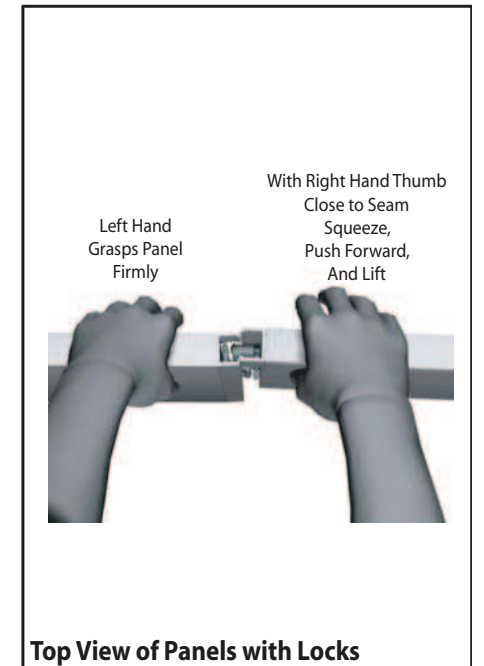

The first level of components contain panel locks that are located at the top of the panel for extra stability and seamless connection. When disassembling panels twist top connection slightly and lift right panel upward.

WHEN DISASSEMBLING ALUMINUM EXTRUSION, TIGHTEN ALL SETSCREWS AND LOCKS TO PREVENT LOSS DURING SHIPPING

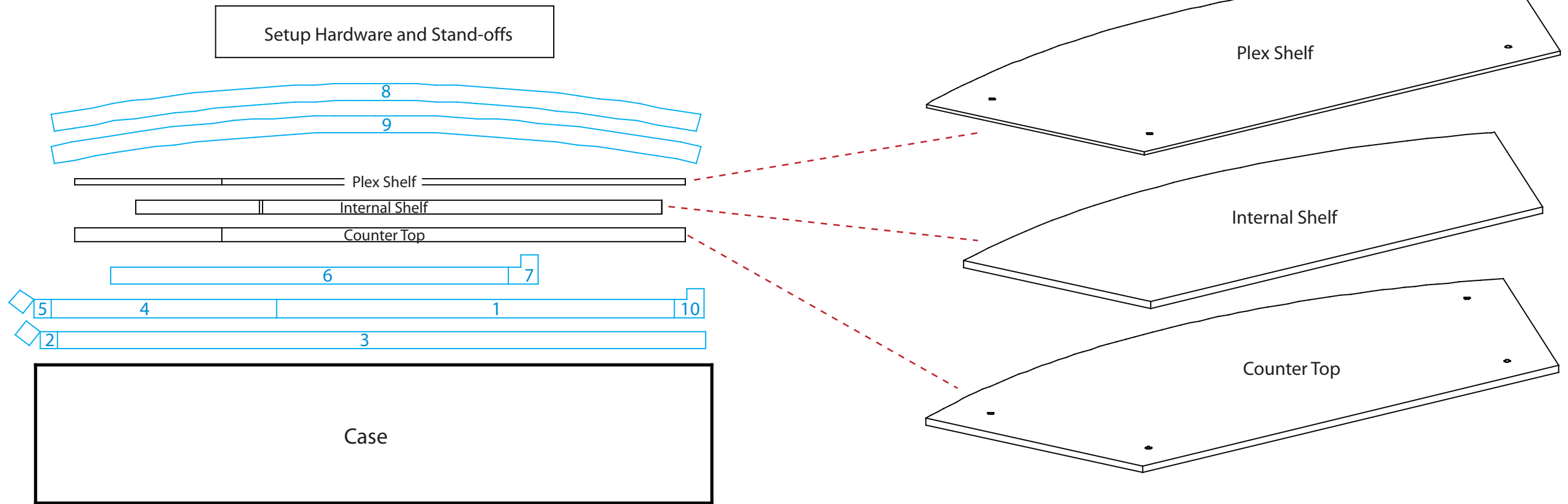

WHEN DISASSEMBLING ALUMINUM EXTRUSION, TIGHTEN ALL SETSCREWS AND LOCKS TO PREVENT LOSS DURING SHIPPING