

# euro It | *HYBRIDS*

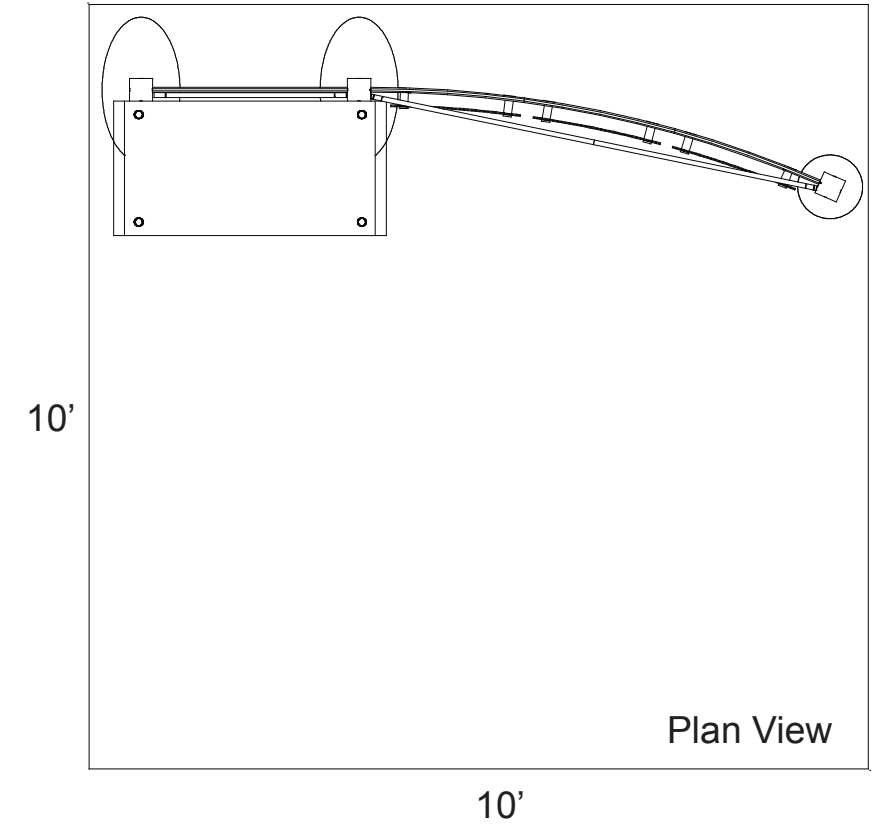
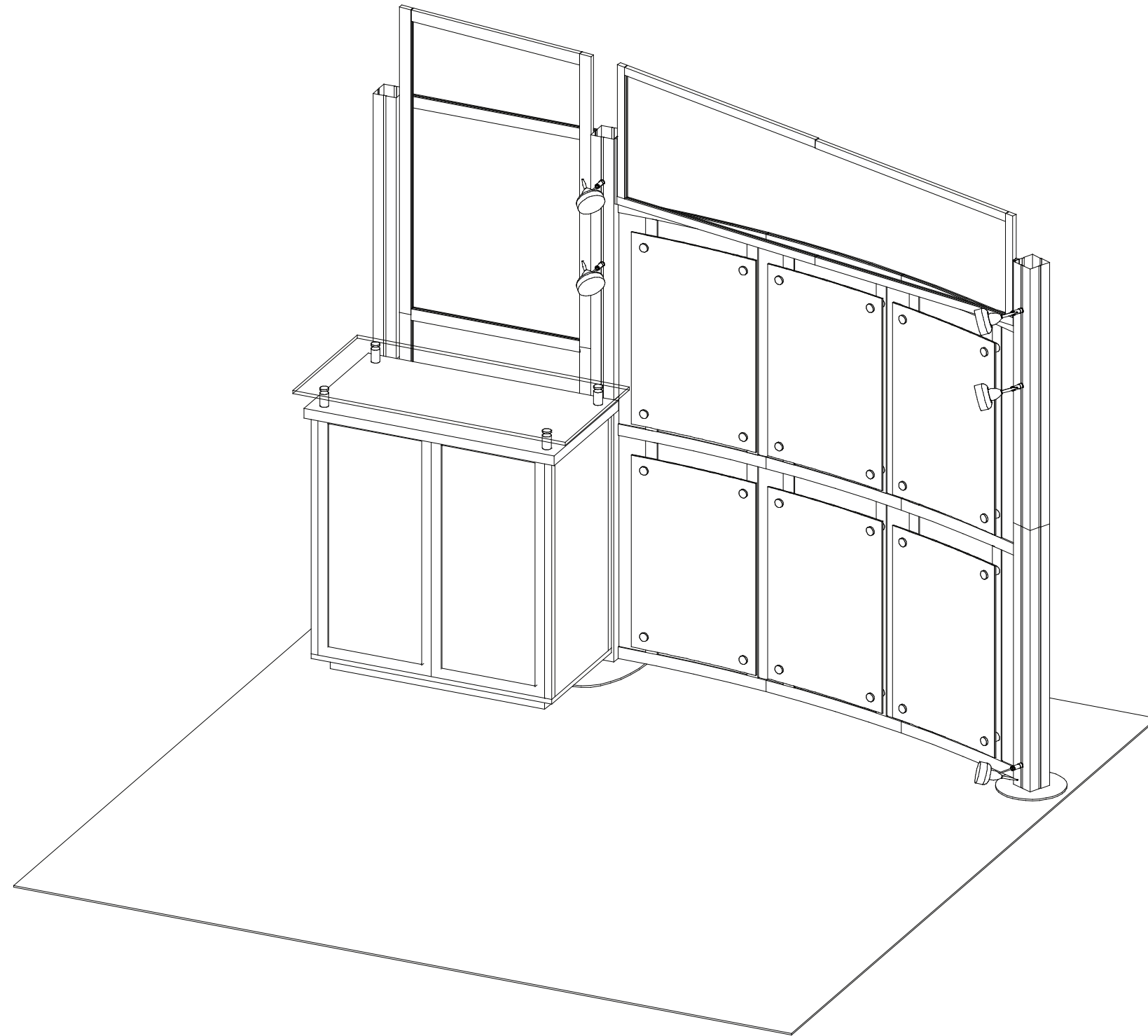

WHEN DISASSEMBLING ALUMINUM EXTRUSION, TIGHTEN ALL SETSCREWS AND LOCKS TO PREVENT LOSS DURING SHIPPING

# euro lt | HYBRIDS

## Using Your Setup Instructions

The Euro LT Hybrids Setup Instructions are created specifically for your configuration. They are laid out sequentially in levels, including exploded views, and a logical series of detailed steps to assemble the main structure and components. We encourage you to study the instructions **before** attempting to assemble your exhibit.

Each page reminds you to tighten the setscrews after disassembling your exhibit to prevent loss of the locks and setscrews (see below in RED). This is VERY IMPORTANT.

## Cleaning and Packing Your Display

- 1) Use care when cleaning aluminum extrusion or acrylic inserts. Use only non-abrasive cleaners.
- 2) When cleaning laminate inserts, countertops, or panels use mild cleansers and a soft material such as cotton.
- 3) Keep all display components away from extreme heat and long exposure to sunlight to avoid warping and fading.
- 4) Retain all packing material. It will make re-packing much easier and will reduce the likelihood of shipping damage.

## General Setup Instructions for Extrusion System



The Tool

Most exhibits can be assembled with the supplied Hex Key Tool. Occasionally, a flat head screwdriver may be required.

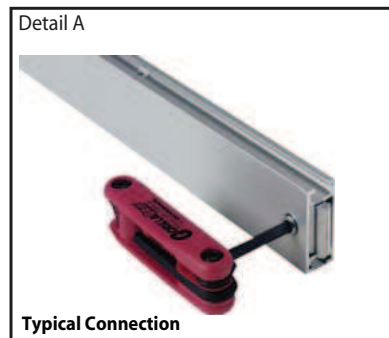

Typical Connection

Most horizontal extrusion connections have a patented expandable lock. This lock inserts into the groove of an opposing extrusion. Tightening the lock with the Hex Key Tool expands the lock and creates a strong positive connection.



Typical Connection (cont'd)

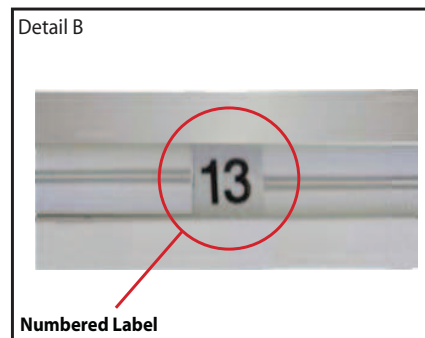

Numbered Label

Each extrusion contains a numbered label which corresponds with setup instructions. The label is located within a groove of the extrusion (when possible). With extrusion components the labels contain Black numbers unless otherwise specified.



Horizontal Inline Connection (remove only one setscrew)

Remove only (1) setscrew when disassembling. Replace setscrew in extrusion after assembling it. Before packing, replace setscrew in extrusion to avoid losing it.

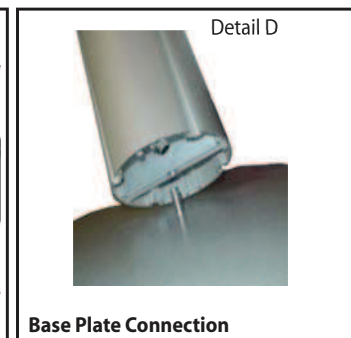

Base Plate Connection

Attach base plate to round or square vertical extrusion using the bolt provided. Be careful not to strip the threads.

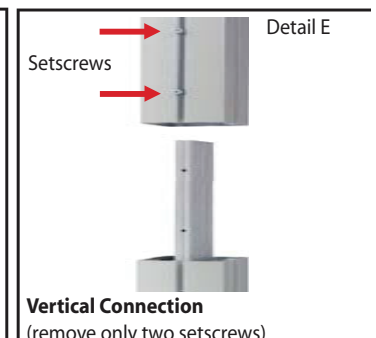

Vertical Connection (remove only two setscrews)

When vertical extrusions are packed in portable cases rather than crates or tubs, they must be broken down into smaller section which then require assembly.

Remove only (2) setscrews when disassembling. Replace setscrews in extrusion after assembling it. Before packing, replace setscrews in extrusion to avoid losing them.

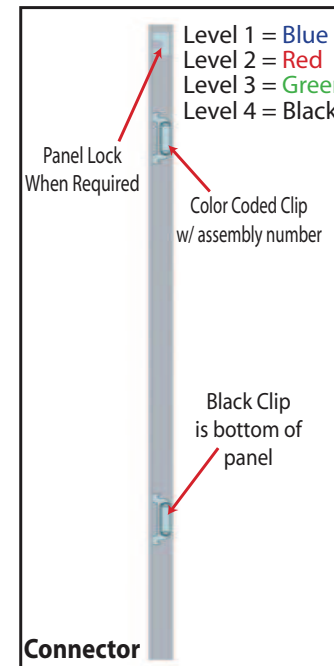

Connector

Each component has 2 clips, the lower clip is ALWAYS black. The top clip is color coded to distinguish which level. The color coded clip also contains the numbered label.

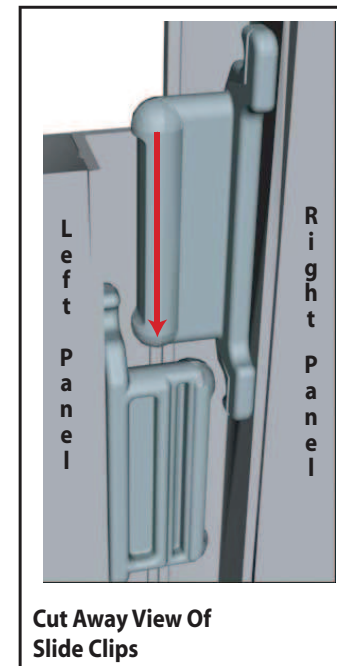

Cut Away View Of Slide Clips

Components connect together by aligning them and sliding downward connecting clips together.

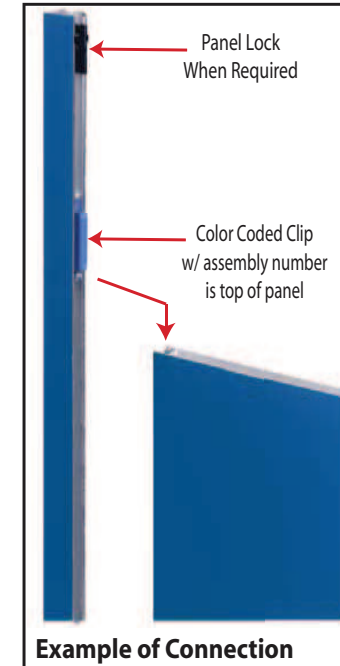

Example of Connection

Configurations are assembled from left to right, usually starting with #1 and following the numbered sequence.

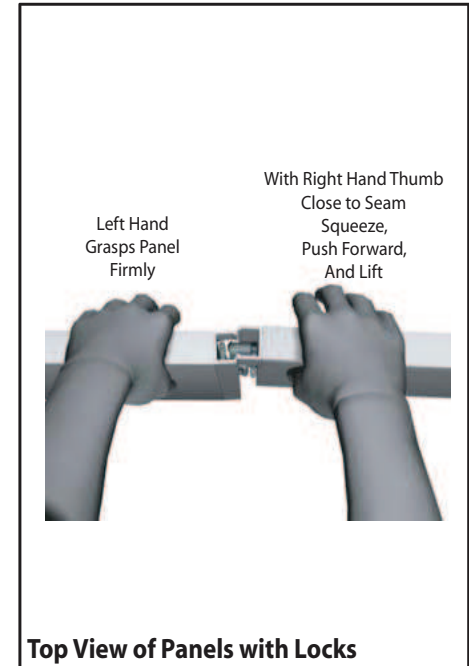

Top View of Panels with Locks

The first level of components contain panel locks that are located at the top of the panel for extra stability and seamless connection. When disassembling panels twist top connection slightly and lift right panel upward.

**WHEN DISASSEMBLING ALUMINUM EXTRUSION, TIGHTEN ALL SETSCREWS AND LOCKS TO PREVENT LOSS DURING SHIPPING**

Item	Qty.	Description
1	2	Oval Base Plate
1a	1	Round Base Plate
2	1	40.875" Square Vertical Extrusion
3	1	40.875" Square Vertical Extrusion
4	1	40.875" Square Vertical Extrusion
5	1	40.875" Square Vertical Extrusion w/ Graphic Header Attachment
6	1	40.875" Square Vertical Extrusion
7	1	40.875" Square Vertical Extrusion w/ Graphic Header Attachment
8	1	30" w Horizontal Extrusion
9	1	30" w Horizontal Extrusion
10a/10b	1/1	35.644" w Curved Horizontal Extrusion
11a/11b	1/1	35.644" w Curved Horizontal Extrusion
12a/12b	1/1	35.644" w Curved Horizontal Extrusion
13	12	33.064" w Vertical Extrusion w/ Drilled Holes for Graphic Attachment

Steps:

- 1) Attach vertical extrusions [2 and 4] to oval base plates [1] and vertical extrusion [6] to round base plate [1a].
- 2) Attach upper vertical extrusions to lower vertical extrusions [3 to 2, 5 to 4 and 7 to 6].
- 3) Attach horizontal extrusions [8 and 9] between assembled vertical extrusions [2/3 and 4/5].
- 4) Connect curved horizontal extrusions together [10a to 10b, 11a to 11b and 12a to 12b].
- 5) Attach assembled horizontal extrusions [10a/10b] between vertical extrusions [4/5 and 6/7].
- 6) Attach vertical extrusions [13] to horizontal extrusions [10a/10b], placing inserts between verticals as shown.
- 7) Attach assembled horizontal extrusions [11a/11b] between vertical extrusions [4/5 and 6/7] and atop vertical extrusions [13].
- 8) Attach vertical extrusions [13] to horizontal extrusions [11a/11b], placing inserts between verticals as shown.
- 9) Attach assembled horizontal extrusions [12a/12b] between vertical extrusions [4/5 and 6/7] and atop vertical extrusions [13].

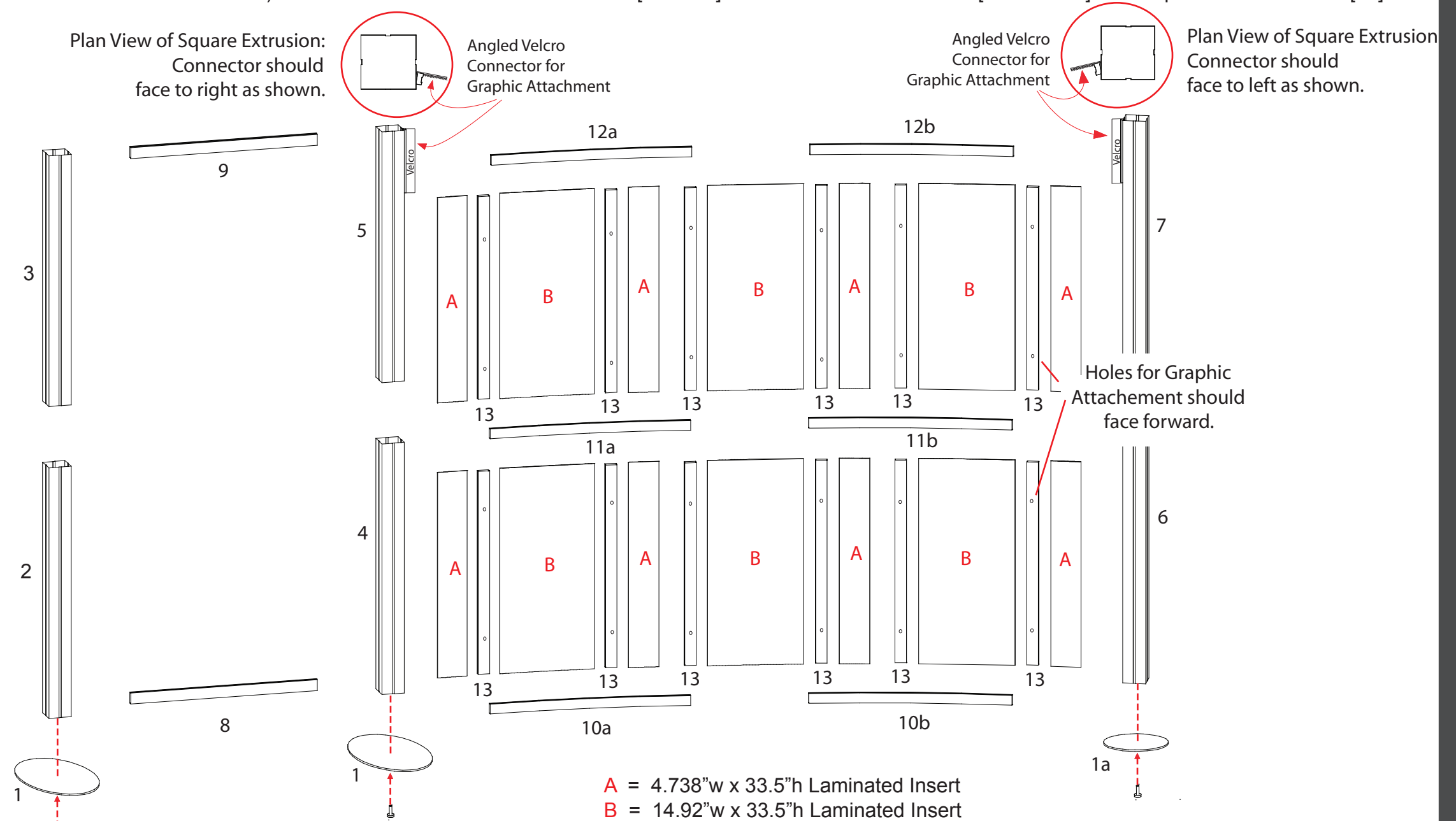

**WHEN DISASSEMBLING ALUMINUM EXTRUSION, TIGHTEN ALL SETSCREWS AND LOCKS TO PREVENT LOSS DURING SHIPPING**

Steps:

1) Attach graphics to backwall using stand-off attachment, see Graphic Attachment Detail.

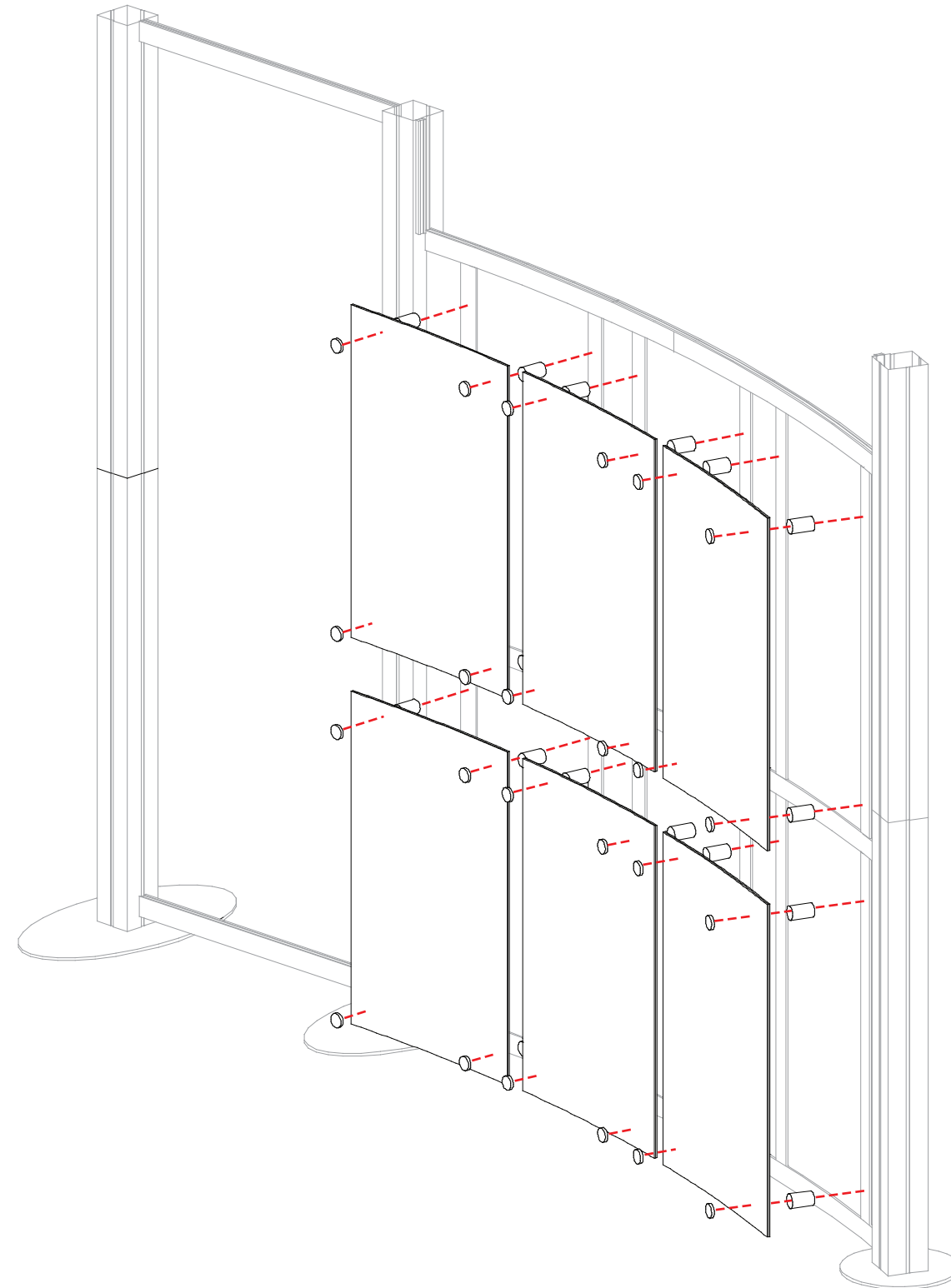

*Graphic Attachment*

Plex      Graphic

Place graphic between Plex.

Attach graphic to backwall using stand-offs.

**WHEN DISASSEMBLING ALUMINUM EXTRUSION, TIGHTEN ALL SETSCREWS AND LOCKS TO PREVENT LOSS DURING SHIPPING**

866.652.2100

Item	Qty.	Description
20	1	29.594"w Horizontal Extrusion w/ Attached Velcro to BACK of Extrusion
21	1	45.959"h Vertical Extrusion w/ Attached Velcro to BACK of Extrusion
22	1	47.75"h Vertical Extrusion w/ Attached Velcro to BACK of Extrusion
23	1	45.959"h Vertical Extrusion w/ Attached Velcro to BACK of Extrusion
24	1	45.806"h Vertical Extrusion w/ Attached Velcro to BACK of Extrusion
25	1	26.011"w Horizontal Extrusion
26	1	26.164"w Horizontal Extrusion w/ Attached Velcro to BACK of Extrusion

Steps:

- 1) Connect vertical extrusions [21 to 22 and 23 to 24] together.
- 2) Attach horizontal extrusions [25 and 26] between assembled vertical extrusions [21/22 and 23/24].
- 3) Attach assembled frame to horizontal extrusion [20] as shown.
- 4) Apply graphic to assembled frame, see Attaching Graphic detail.

**NOTE:** Hook for attachment to backwall.

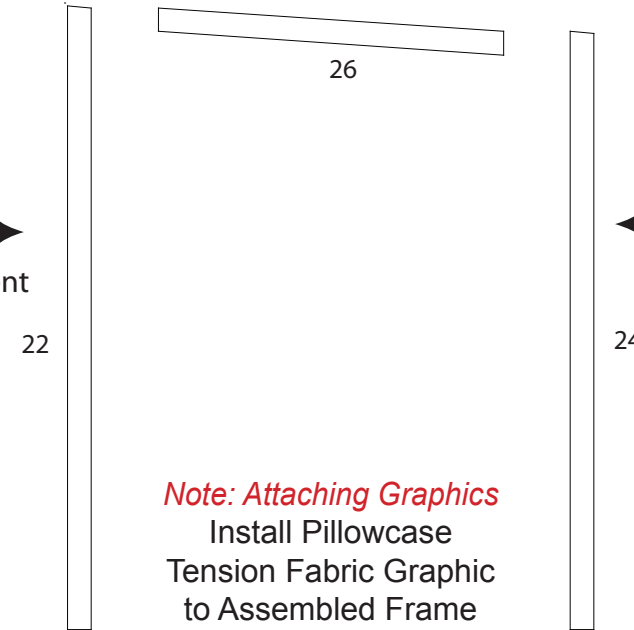

**NOTE:** Hook for attachment to backwall.

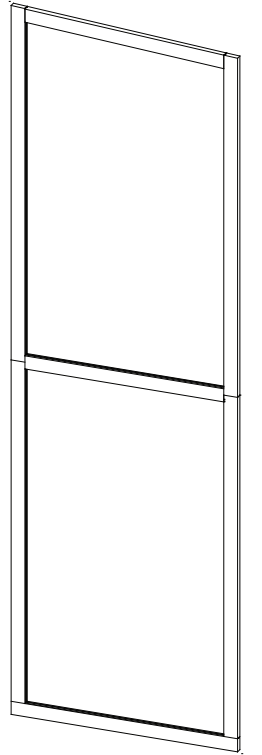
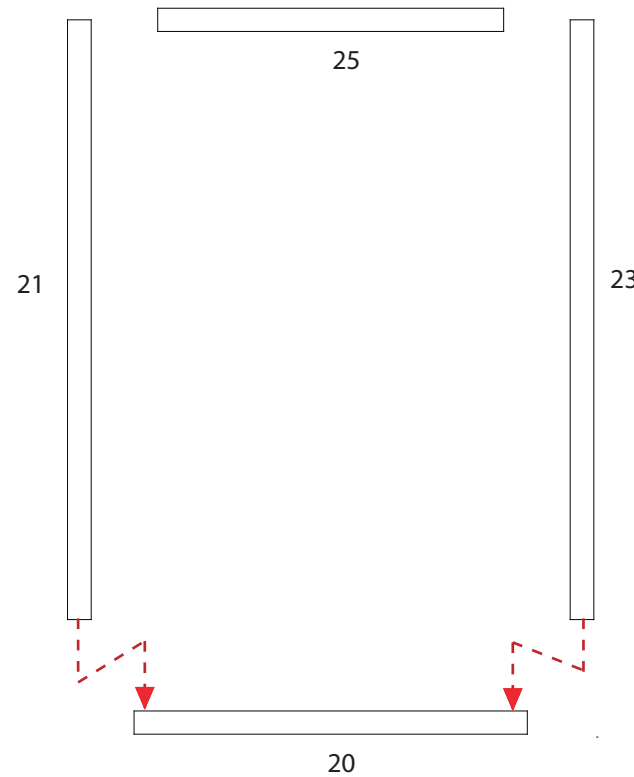

**WHEN DISASSEMBLING ALUMINUM EXTRUSION, TIGHTEN ALL SETSCREWS AND LOCKS TO PREVENT LOSS DURING SHIPPING**

866.652.2100

Item	Qty.	Description
27a/27b	1/1	34.662"w Horizontal Extrusion w/ Attached Velcro to BACK of Extrusion
28	1	20.656"h Vertical Extrusion w/ Attached Velcro to BACK of Extrusion
29	1	15.906"h Vertical Extrusion w/ Attached Velcro to BACK of Extrusion
30a/30b	1/1	33.465"w Horizontal Extrusion w/ Attached Velcro to BACK of Extrusion

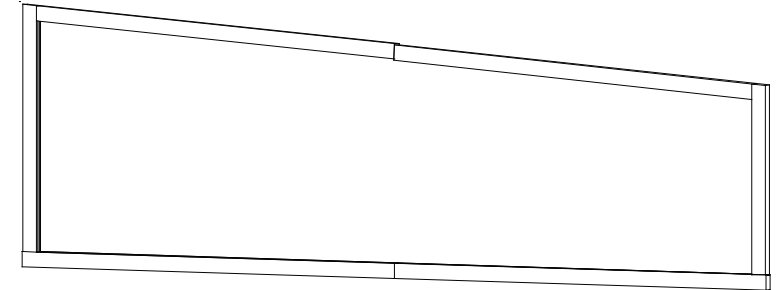

Steps:

- 1) Connect horizontal extrusions [27a to 27b and 30a to 30b] together.
- 2) Attach assembled horizontal extrusions [27a/27b and 30a/30b] between vertical extrusions [28 and 29].
- 3) Attach top section to assembled horizontal extrusion [27a/27b] as shown.
- 4) Apply graphic to assembled frame, see Attaching Graphic detail.

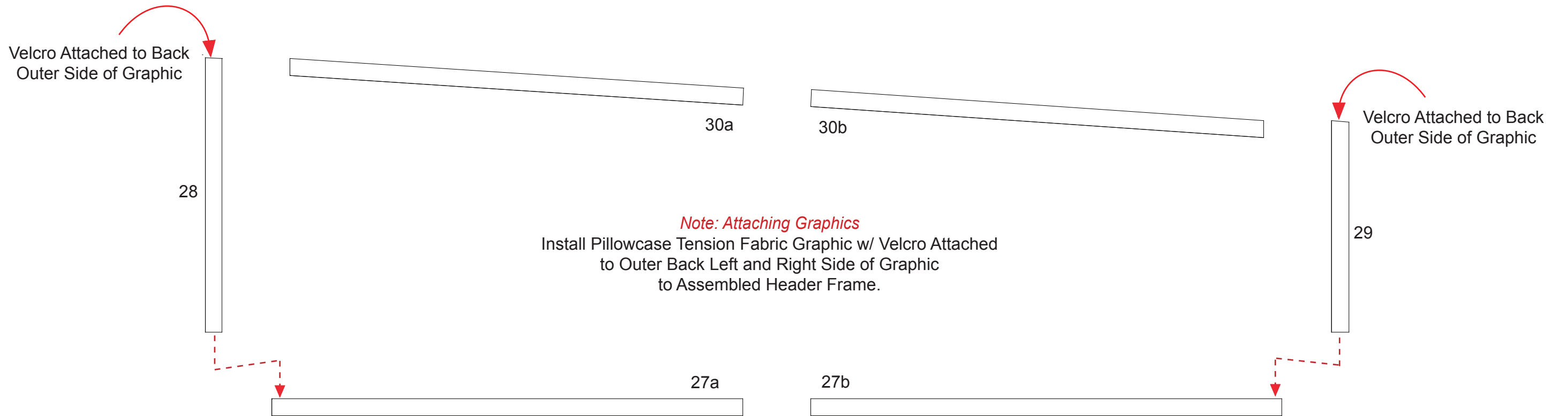

**WHEN DISASSEMBLING ALUMINUM EXTRUSION, TIGHTEN ALL SETSCREWS AND LOCKS TO PREVENT LOSS DURING SHIPPING**

866.652.2100

Steps:

- 1) Hook 29.59" w x 95.5" h frame to upper horizontal extrusion [9] as shown.
- 2) Attach 69.32" w x 20.656" h frame to header attachment located at top of vertical extrusions [5 and 7] using setscrews.
- 3) Attach lights to assembled backwall as shown.

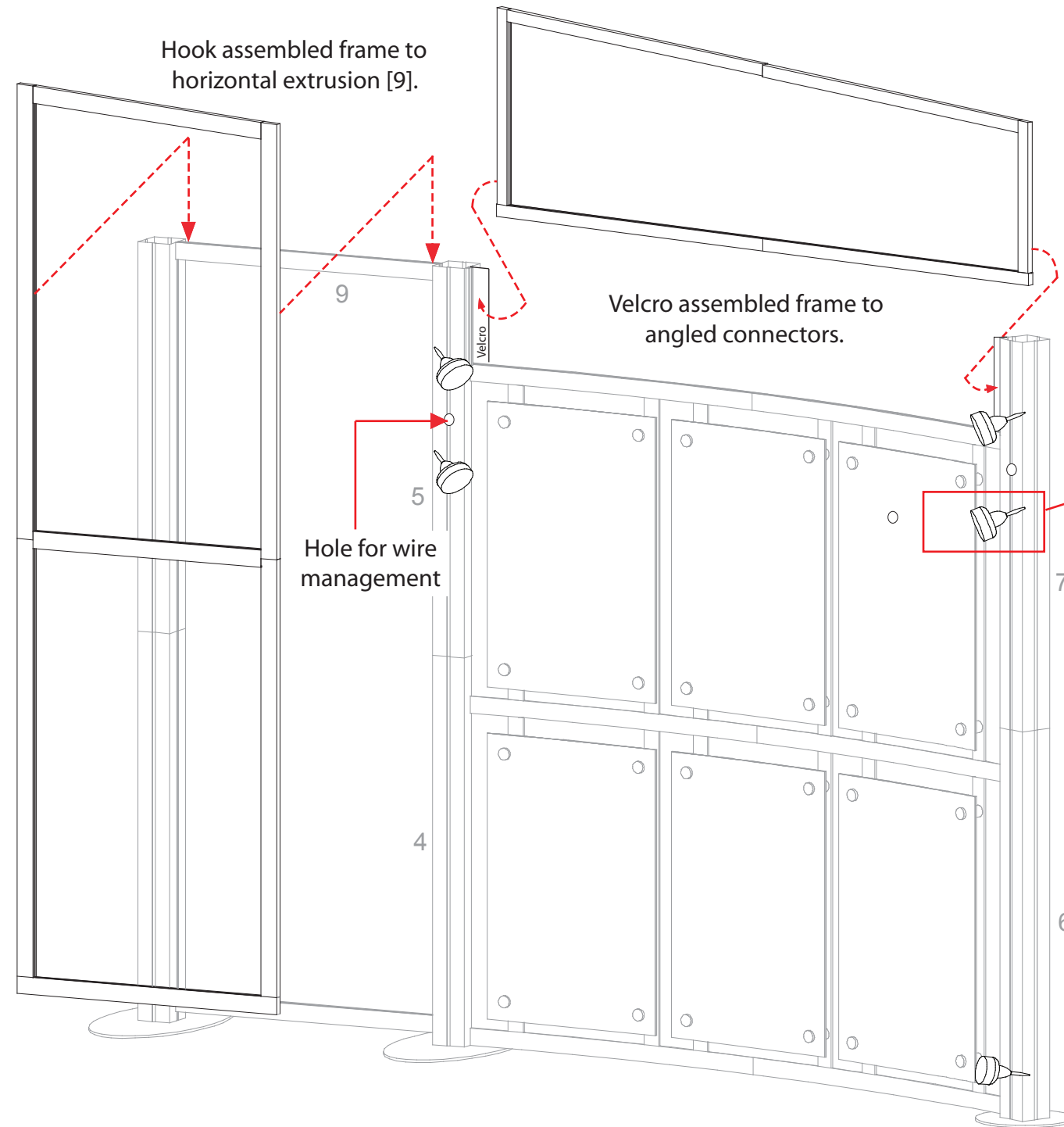

*Example of Rail Light Attachment*

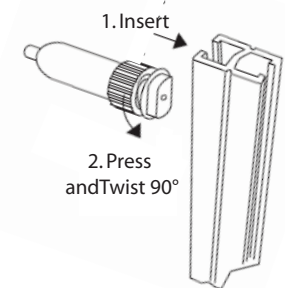

Slide fixed clip into groove of extrusion [4/5 and 6/7].

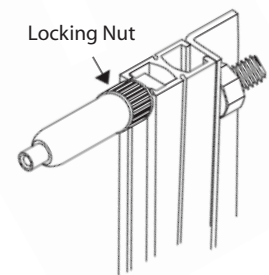

Tighten locking nut to secure light in place

**WHEN DISASSEMBLING ALUMINUM EXTRUSION, TIGHTEN ALL SETSCREWS AND LOCKS TO PREVENT LOSS DURING SHIPPING**

866.652.2100

Item Number	Description
1	17.5" w x 38" h Flat Panel w/ Door
2	17.5" w x 38" h Flat Panel w/ Door
3	38" h 90° Connector
4	17.5" w x 38" h Flat Panel
5	38" h 90° Connector
6	17.5" w x 38" h Flat Panel
7	17.5" w x 38" h Flat Panel
8	38" h 90° Connector
9	17.5" w x 38" h Flat Panel
10	38" h 90° Connector

- Steps:
- 1) Assemble by starting at panel #1 and continue in numerical order.
  - 2) Place assembled pedestal on base.
  - 3) Velcro internal shelf supports to inside of pedestal.
  - 4) Set internal shelf atop shelf supports.
  - 5) Set counter top on assembled base.
  - 6) Attach Arborite shelf to counter top using stand-offs as shown.

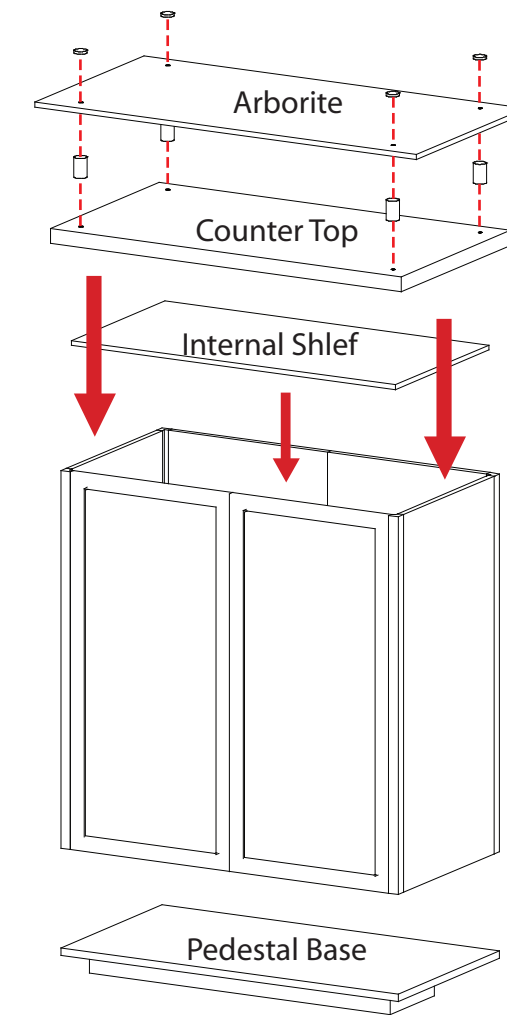
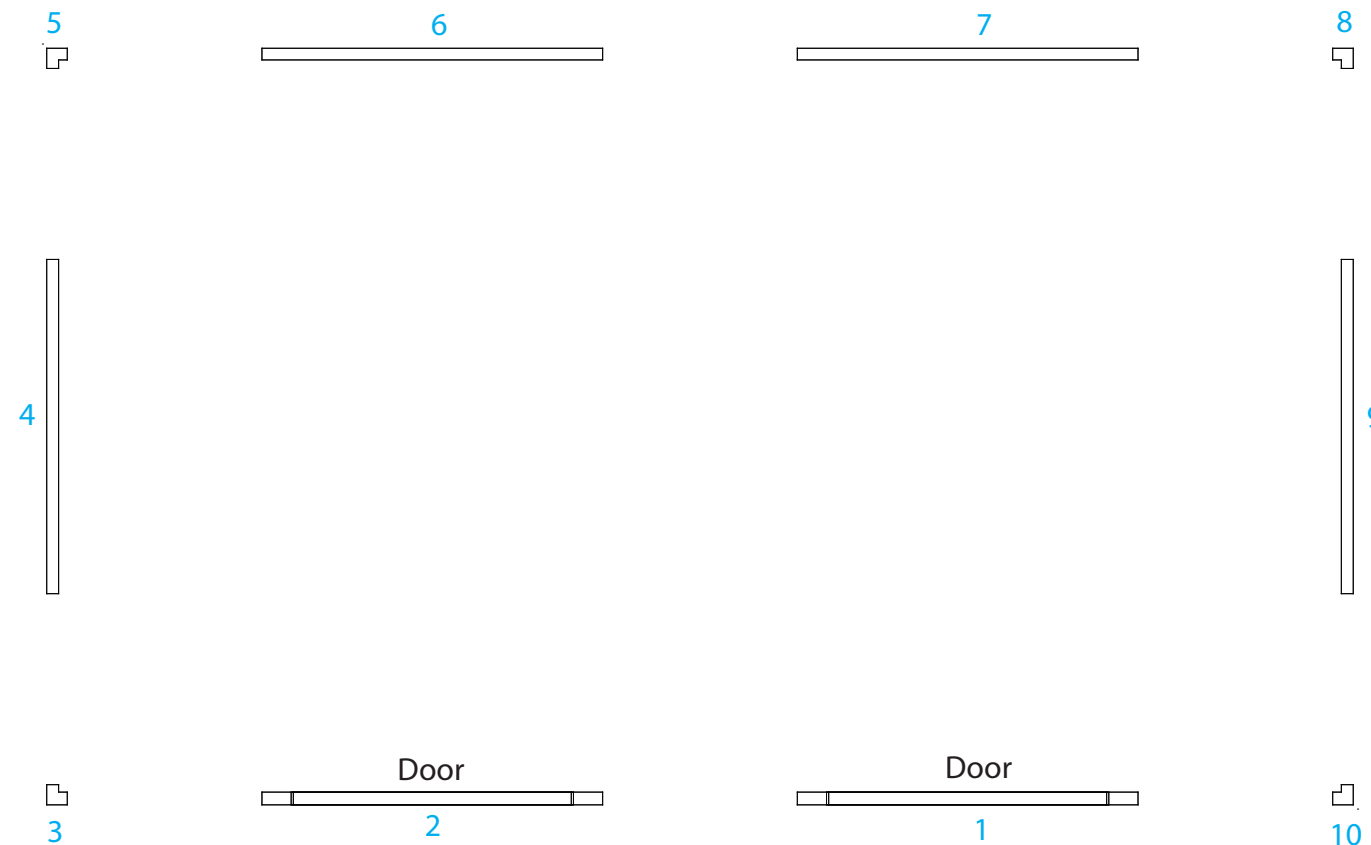
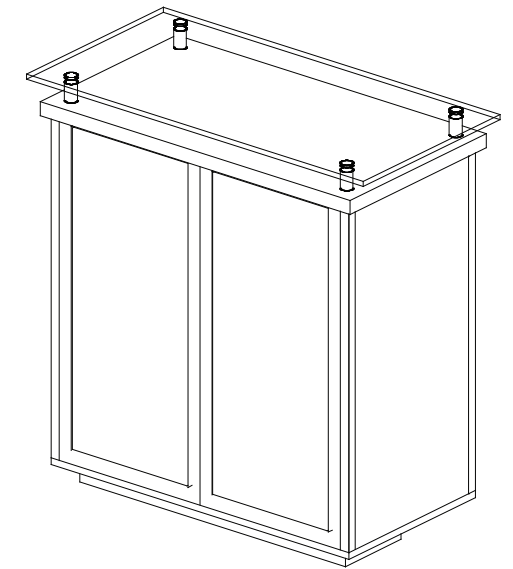

**WHEN DISASSEMBLING ALUMINUM EXTRUSION, TIGHTEN ALL SETSCREWS AND LOCKS TO PREVENT LOSS DURING SHIPPING**

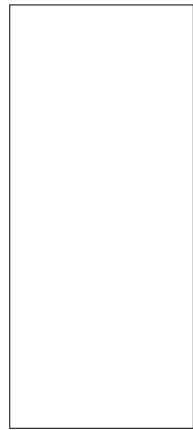

14.738"W x 33.5"H  
Laminated Insert

Qty. : 6

Located in Case : \_\_\_\_\_



4.738"W x 33.5"H  
Laminated Insert

Qty. : 8

Located in Case : \_\_\_\_\_

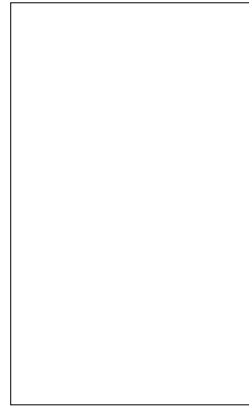

20"W x 30"H  
1/8" Plex

Qty. : 12

Located in Case : \_\_\_\_\_

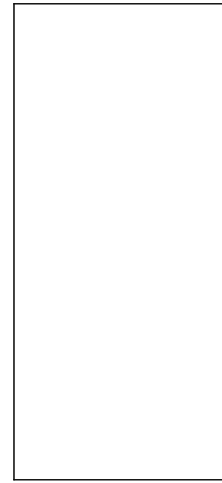

Internal Shelf

Qty. : 1

Located in Case : \_\_\_\_\_

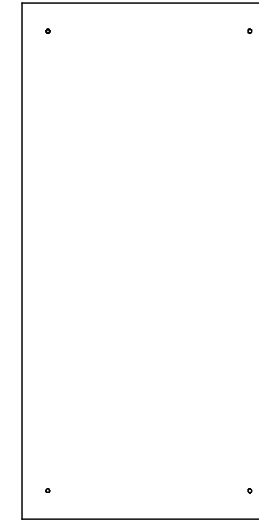

Counter Top

Qty. : 1

Located in Case : \_\_\_\_\_

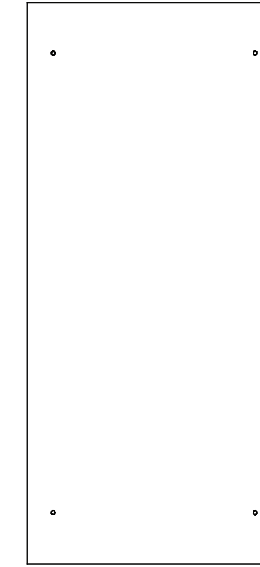

PlexShelf

Qty. : 1

Located in Case : \_\_\_\_\_

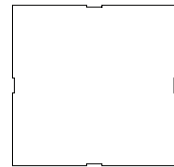

40.875" Square Extrusion

Qty. : 6

Located in Case : \_\_\_\_\_



Shelf Support

Qty. : 4

Located in Case : \_\_\_\_\_

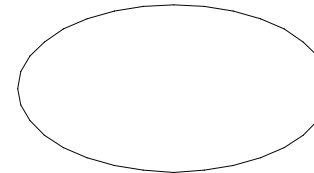

Oval Base Plate

Qty. : 2

Located in Case : \_\_\_\_\_

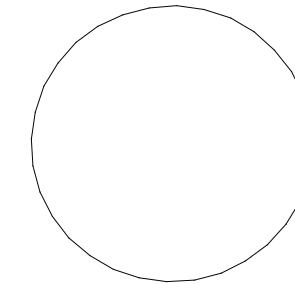

Round Base Plate

Qty. : 1

Located in Case : \_\_\_\_\_

- Backwall Section -

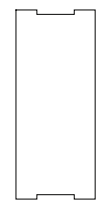

35.64" Curved Extrusion

Qty. : 6

Located in Case : \_\_\_\_\_

30" Extrusion

Qty. : 2

Located in Case : \_\_\_\_\_

33.064" Extrusion

Qty. : 12

Located in Case : \_\_\_\_\_

- 69.32"w x 20.656"h Frame -



34.662" Extrusion

Qty. : 2

Located in Case : \_\_\_\_\_

20.656" Extrusion

Qty. : 1

Located in Case : \_\_\_\_\_

15.906" Extrusion

Qty. : 1

Located in Case : \_\_\_\_\_

33.465" Extrusion

Qty. : 2

Located in Case : \_\_\_\_\_

- 29.59"w x 95.5"h Frame -



29.594" Extrusion

Qty. : 1

Located in Case : \_\_\_\_\_

45.959" Extrusion

Qty. : 2

Located in Case : \_\_\_\_\_

47.75" Extrusion

Qty. : 1

Located in Case : \_\_\_\_\_

45.806" Extrusion

Qty. : 1

Located in Case : \_\_\_\_\_

26.011" Extrusion

Qty. : 1

Located in Case : \_\_\_\_\_

26.164" Extrusion

Qty. : 1

Located in Case : \_\_\_\_\_

Additional Accessories:

Setup Hardware - in Case \_\_\_\_\_

Backwall Graphics - in Case \_\_\_\_\_

\_\_\_\_\_  
\_\_\_\_\_  
\_\_\_\_\_  
\_\_\_\_\_

WHEN DISASSEMBLING ALUMINUM EXTRUSION, TIGHTEN ALL SETSCREWS AND LOCKS TO PREVENT LOSS DURING SHIPPING

866.652.2100

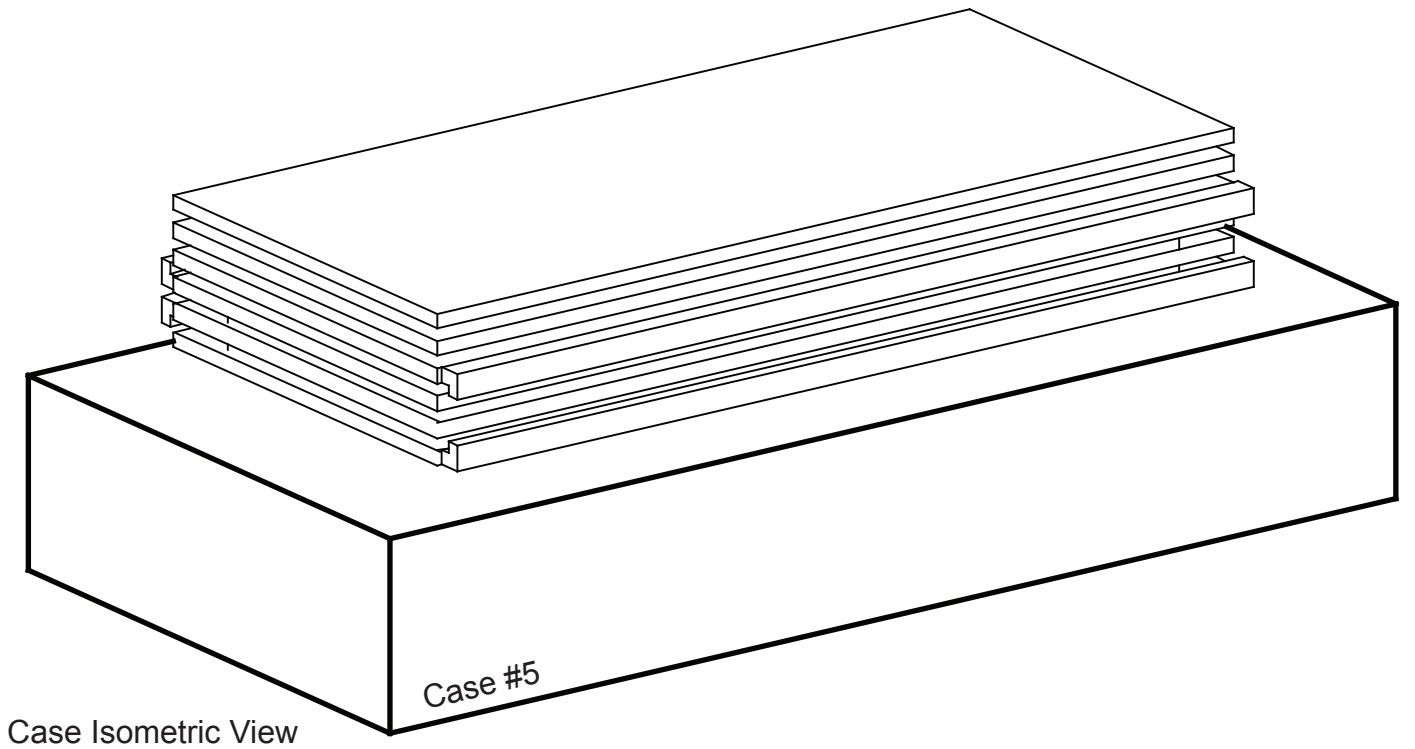
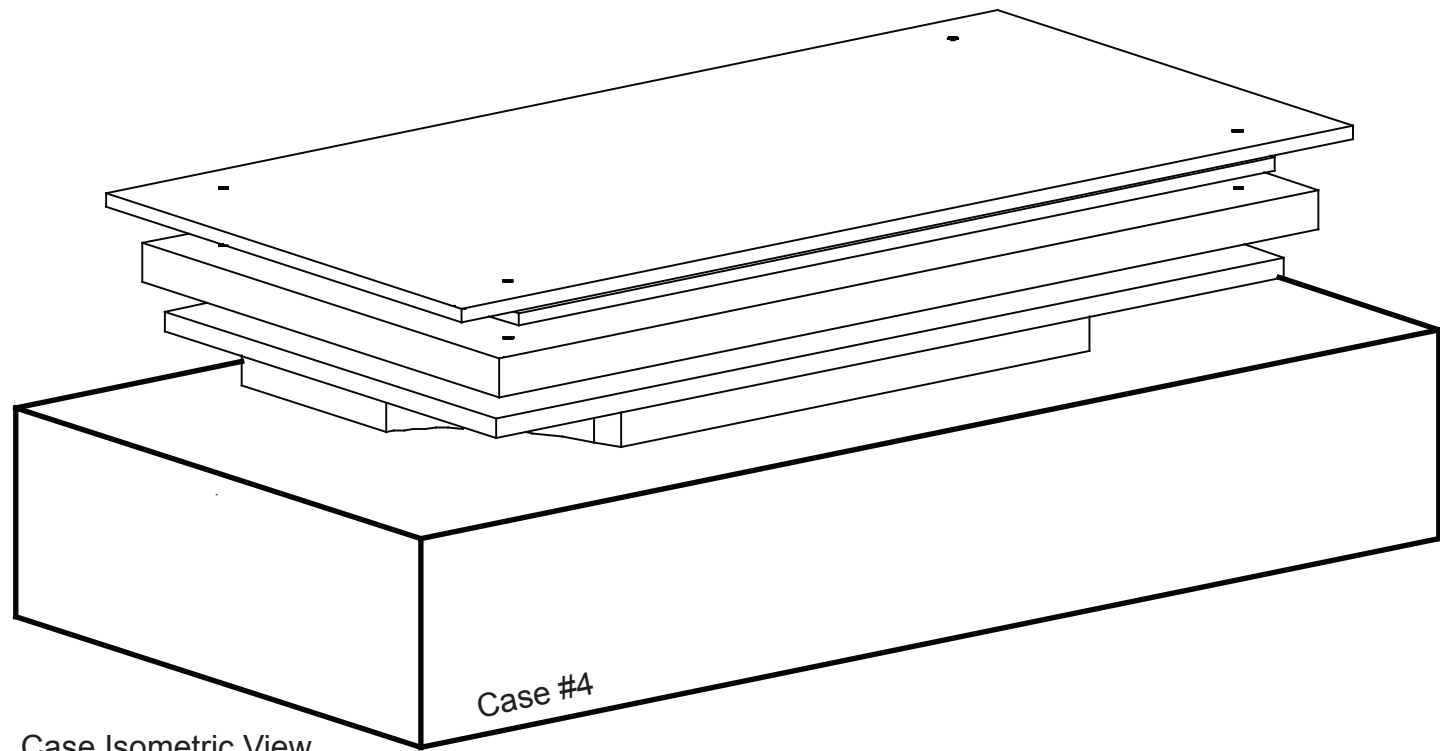

Case Isometric View

Case Isometric View

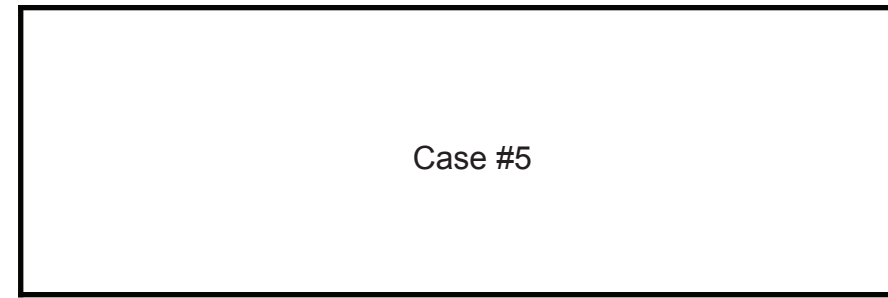
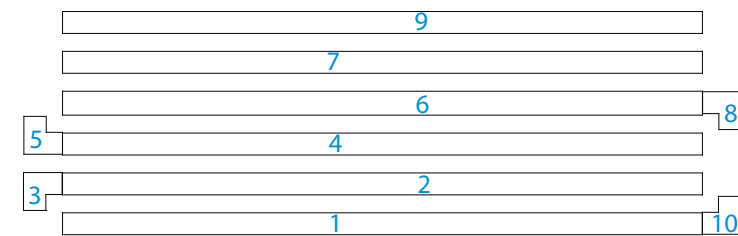
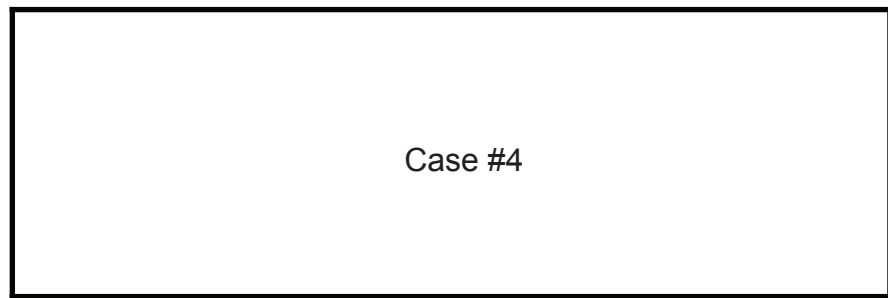
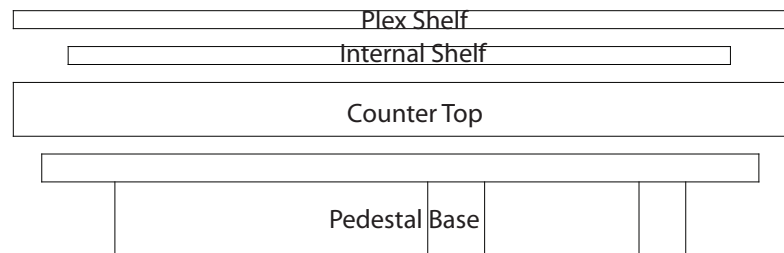

WHEN DISASSEMBLING ALUMINUM EXTRUSION, TIGHTEN ALL SETSCREWS AND LOCKS TO PREVENT LOSS DURING SHIPPING