

euro It | *HYBRIDS*

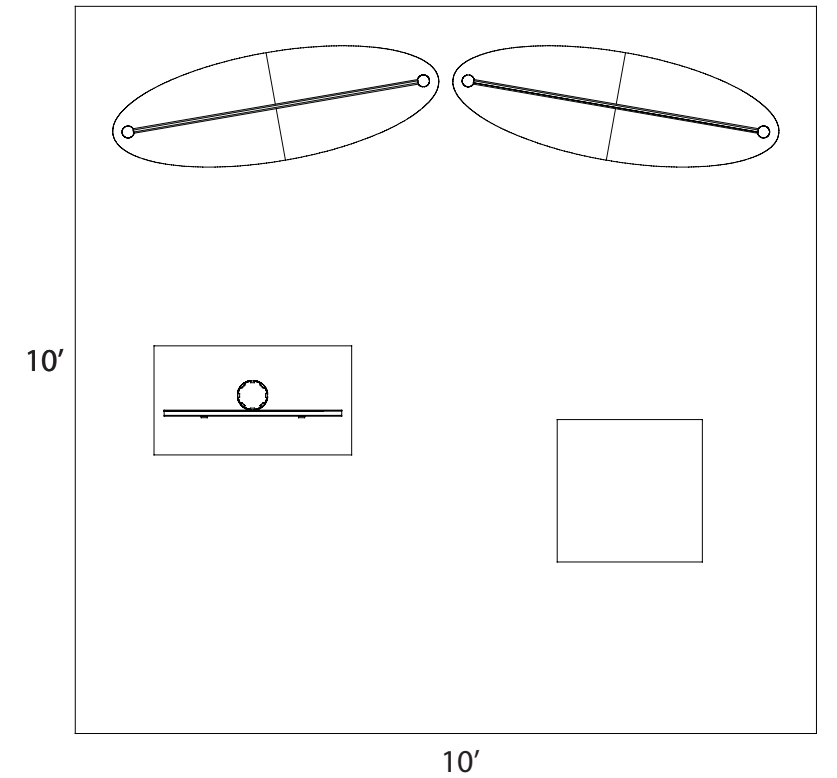
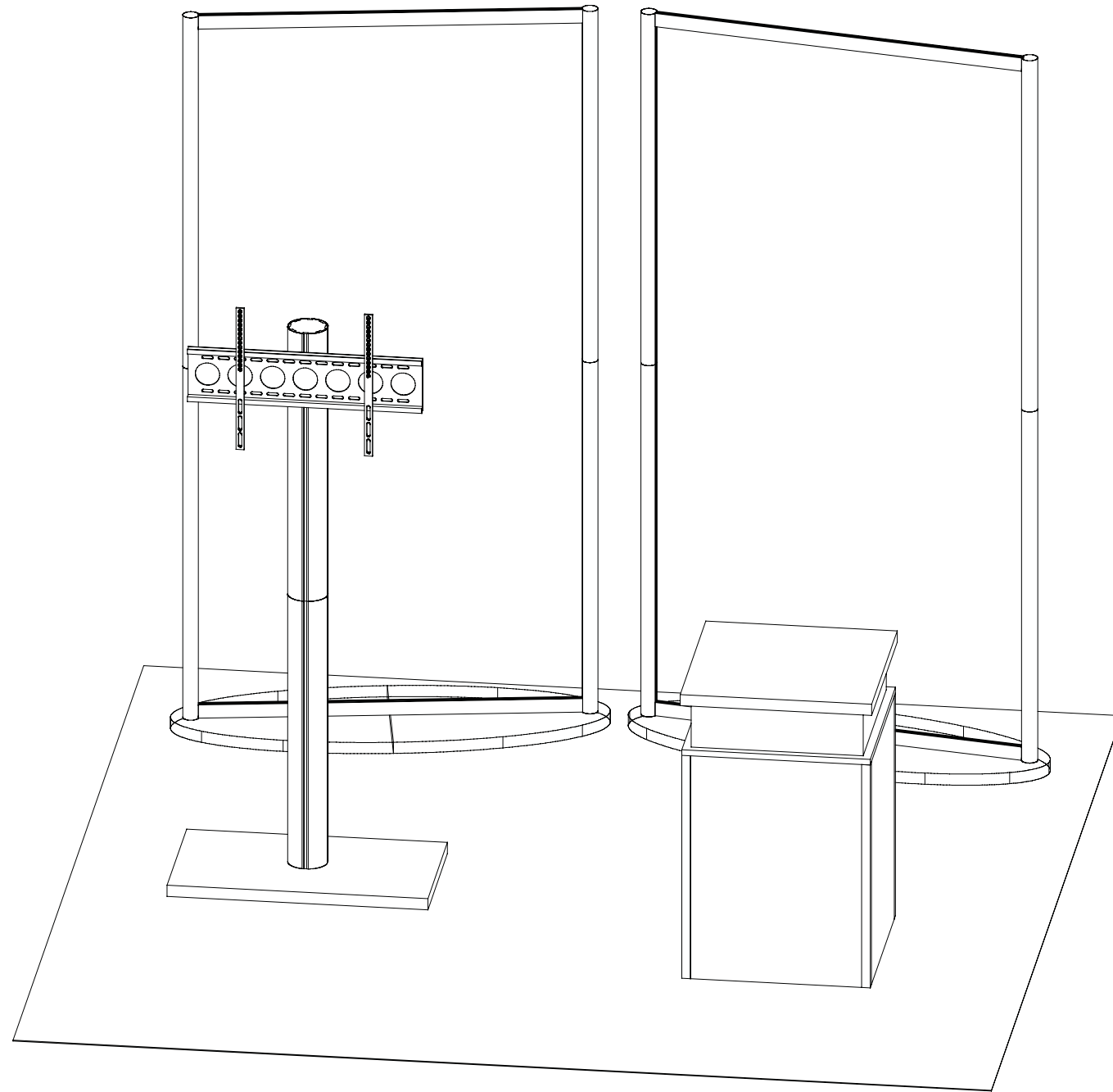

WHEN DISASSEMBLING ALUMINUM EXTRUSION, TIGHTEN ALL SETSCREWS AND LOCKS TO PREVENT LOSS DURING SHIPPING

euro lt | HYBRIDS

Using Your Setup Instructions

The Euro LT Hybrids Setup Instructions are created specifically for your configuration. They are laid out sequentially in levels, including exploded views, and a logical series of detailed steps to assemble the main structure and components. We encourage you to study the instructions **before** attempting to assemble your exhibit.

Each page reminds you to tighten the setscrews after disassembling your exhibit to prevent loss of the locks and setscrews (see below in RED). This is VERY IMPORTANT.

Cleaning and Packing Your Display

- 1) Use care when cleaning aluminum extrusion or acrylic inserts. Use only non-abrasive cleaners.
- 2) When cleaning laminate inserts, countertops, or panels use mild cleansers and a soft material such as cotton.
- 3) Keep all display components away from extreme heat and long exposure to sunlight to avoid warping and fading.
- 4) Retain all packing material. It will make re-packing much easier and will reduce the likelihood of shipping damage.

General Setup Instructions for Extrusion System



The Tool

Most exhibits can be assembled with the supplied Hex Key Tool. Occasionally, a flat head screwdriver may be required.



Typical Connection

Most horizontal extrusion connections have a patented expandable lock. This lock inserts into the groove of an opposing extrusion. Tightening the lock with the Hex Key Tool expands the lock and creates a strong positive connection.



Typical Connection (cont'd)

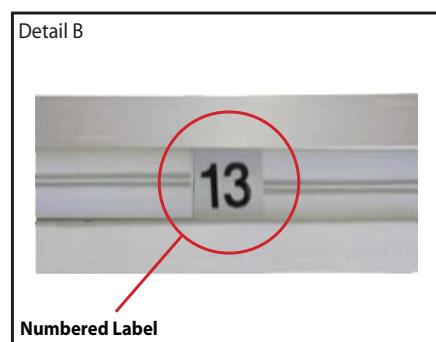

Numbered Label

Each extrusion contains a numbered label which corresponds with setup instructions. The label is located within a groove of the extrusion (when possible). With extrusion components the labels contain Black numbers unless otherwise specified.



Horizontal Inline Connection (remove only one setscrew)

Remove only (1) setscrew when disassembling. Replace setscrew in extrusion after assembling it. Before packing, replace setscrew in extrusion to avoid losing it.

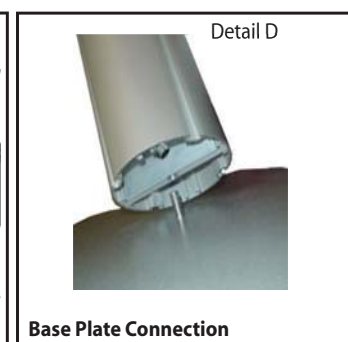

Base Plate Connection

Attach base plate to round or square vertical extrusion using the bolt provided. Be careful not to strip the threads.

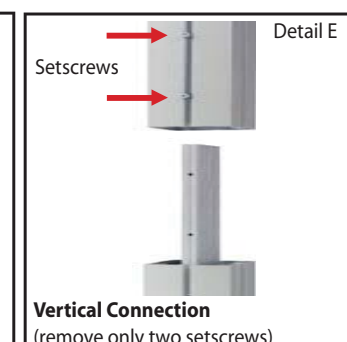

Vertical Connection (remove only two setscrews)

When vertical extrusions are packed in portable cases rather than crates or tubs, they must be broken down into smaller section which then require assembly.

Remove only (2) setscrews when disassembling. Replace setscrews in extrusion after assembling it. Before packing, replace setscrews in extrusion to avoid losing them.

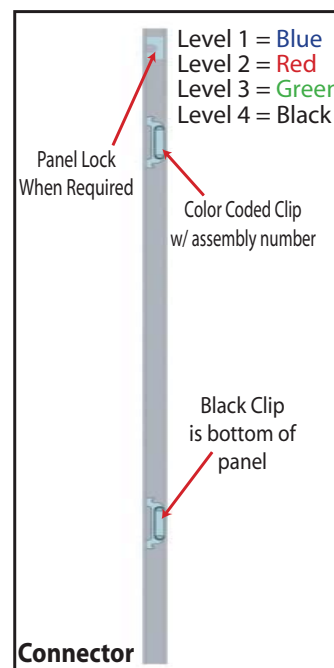

Connector

Each component has 2 clips, the lower clip is ALWAYS black. The top clip is color coded to distinguish which level. The color coded clip also contains the numbered label.

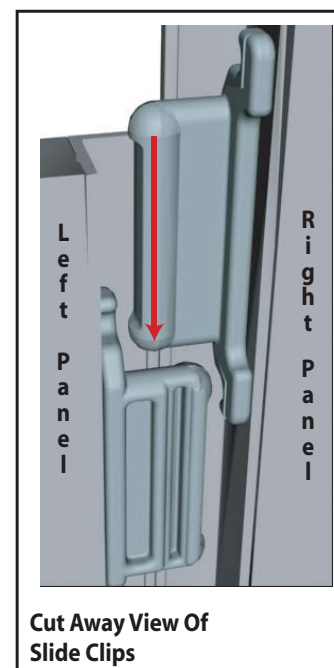

Cut Away View Of Slide Clips

Components connect together by aligning them and sliding downward connecting clips together.

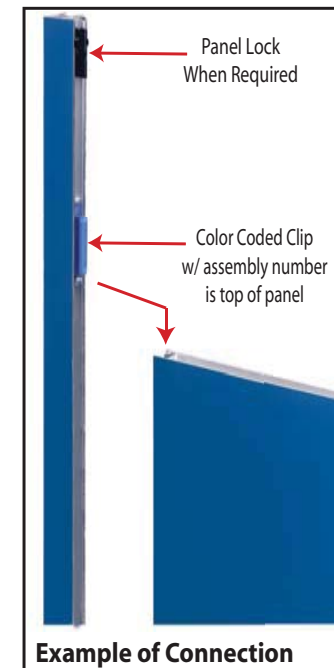

Example of Connection

Configurations are assembled from left to right, usually starting with #1 and following the numbered sequence.

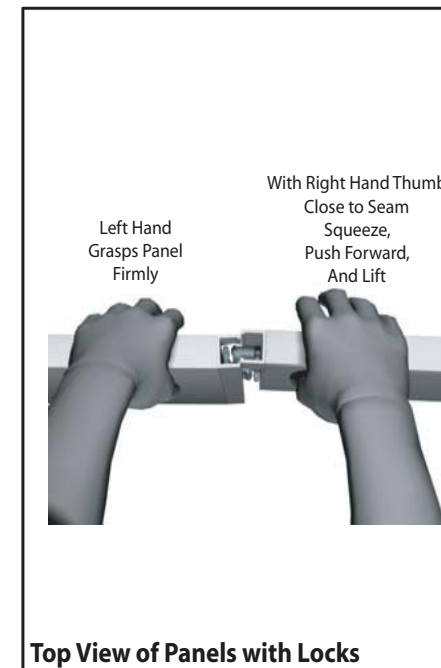

Top View of Panels with Locks

The first level of components contain panel locks that are located at the top of the panel for extra stability and seamless connection. When disassembling panels twist top connection slightly and lift right panel upward.

WHEN DISASSEMBLING ALUMINUM EXTRUSION, TIGHTEN ALL SETSCREWS AND LOCKS TO PREVENT LOSS DURING SHIPPING

866.652.2100

Item	Qty.	Description
1a/1b	1/1	Wooden Base
2	2	47.25" Lower Vertical Extrusion
3	2	47.25" Upper Vertical Extrusion
4	2	46.75"w Horizontal Extrusion w/ Attached Velcro to FRONT and BACK of Extrusion

Steps:

- 1) Connect 2- piece base together, see Multiple Piece Wooden Base Attachment detail.
- 2) Attach lower vertical extrusions to wooden base [2 to 1a/1b], see detail D on general info. page.
- 3) Connect upper and lower vertical extrusions together [3 to 2]
- 4) Attach horizontal extrusions [4] between vertical assemblies [2/3] as shown.
- 5) Apply graphics to assembled frame.
- 6) Repeat steps for an additional 2-sided graphic frame.

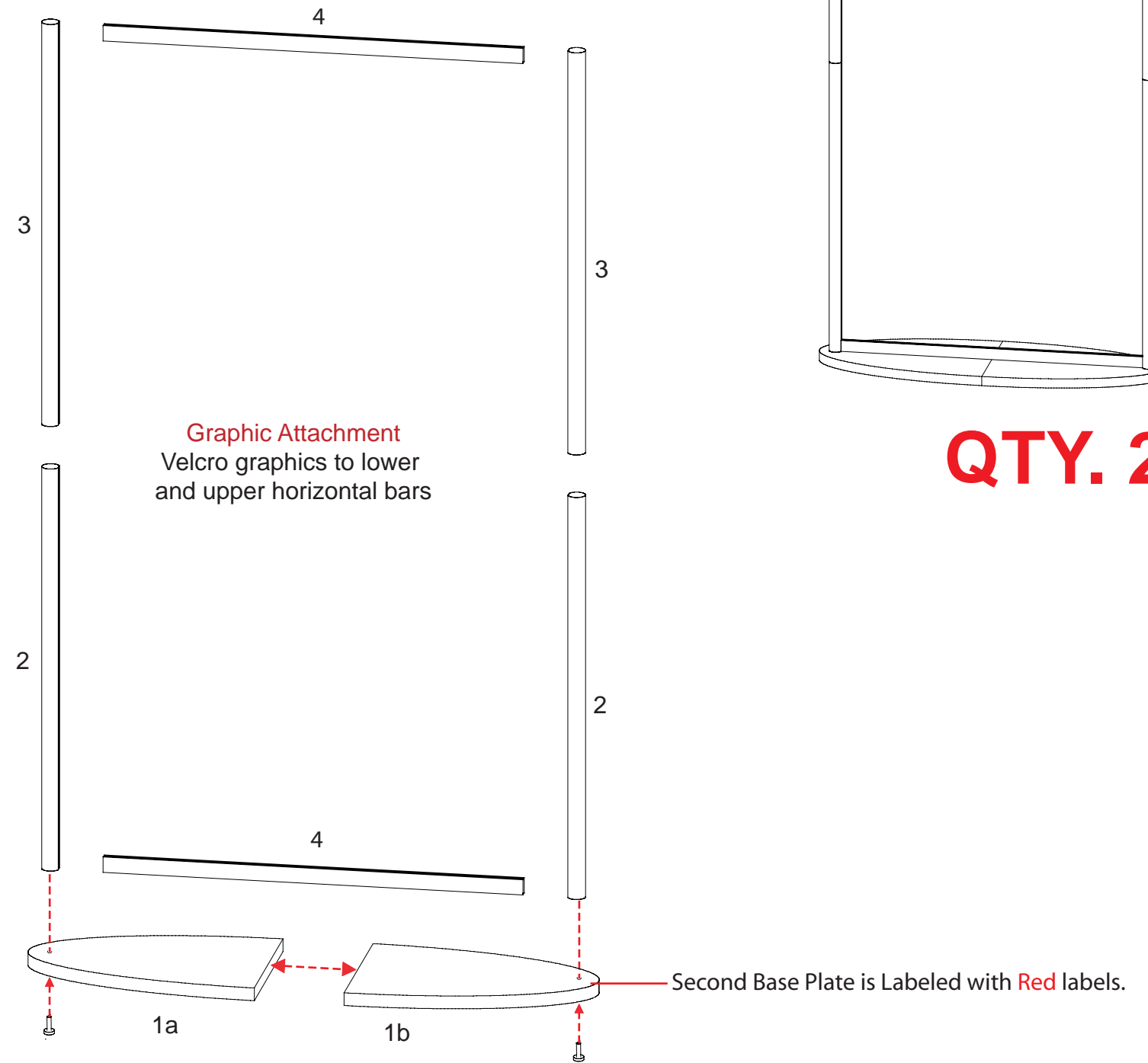
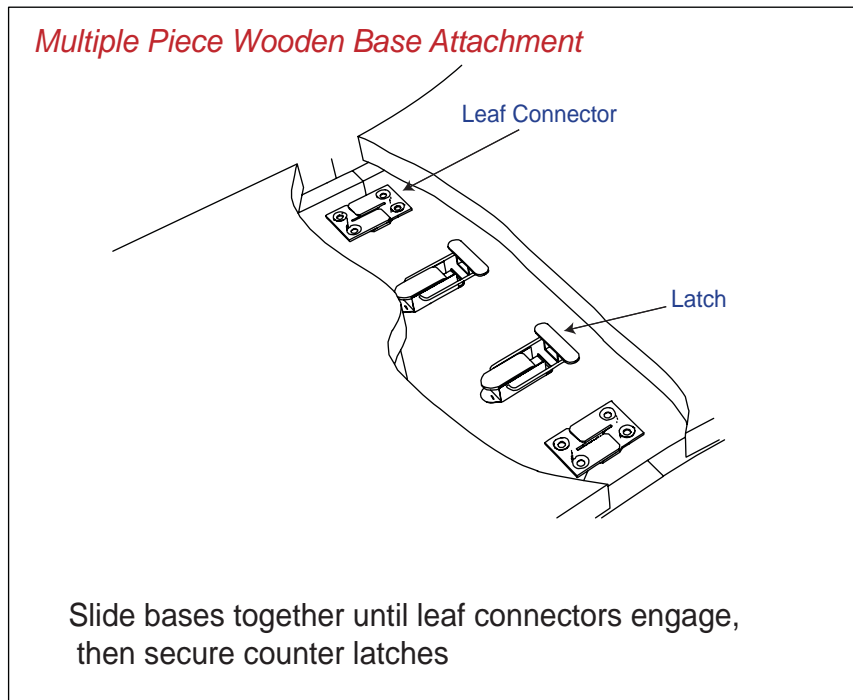

QTY. 2

WHEN DISASSEMBLING ALUMINUM EXTRUSION, TIGHTEN ALL SETSCREWS AND LOCKS TO PREVENT LOSS DURING SHIPPING

866.652.2100

Item	Qty.	Description
5	1	Wooden Base
6	1	36" h Lower Vertical Extrusion
7	1	36" h Upper Vertical Extrusion

Steps:

- 1) Attach lower vertical extrusion [6] to base [5], see detail D on general info. page.
- 2) Attach upper vertical extrusion to lower vertical extrusion [7 to 6].
- 3) Attach monitor mount to assembled stand, see Monitor Mount Attachment detail

Monitor Mount Attachment

Connector



Insert connectors into groove of extrusion and attach plate.



When in desired location tighten in place.



Attach Mount by tightening screws on frontside of Monitor Mount.



Plate

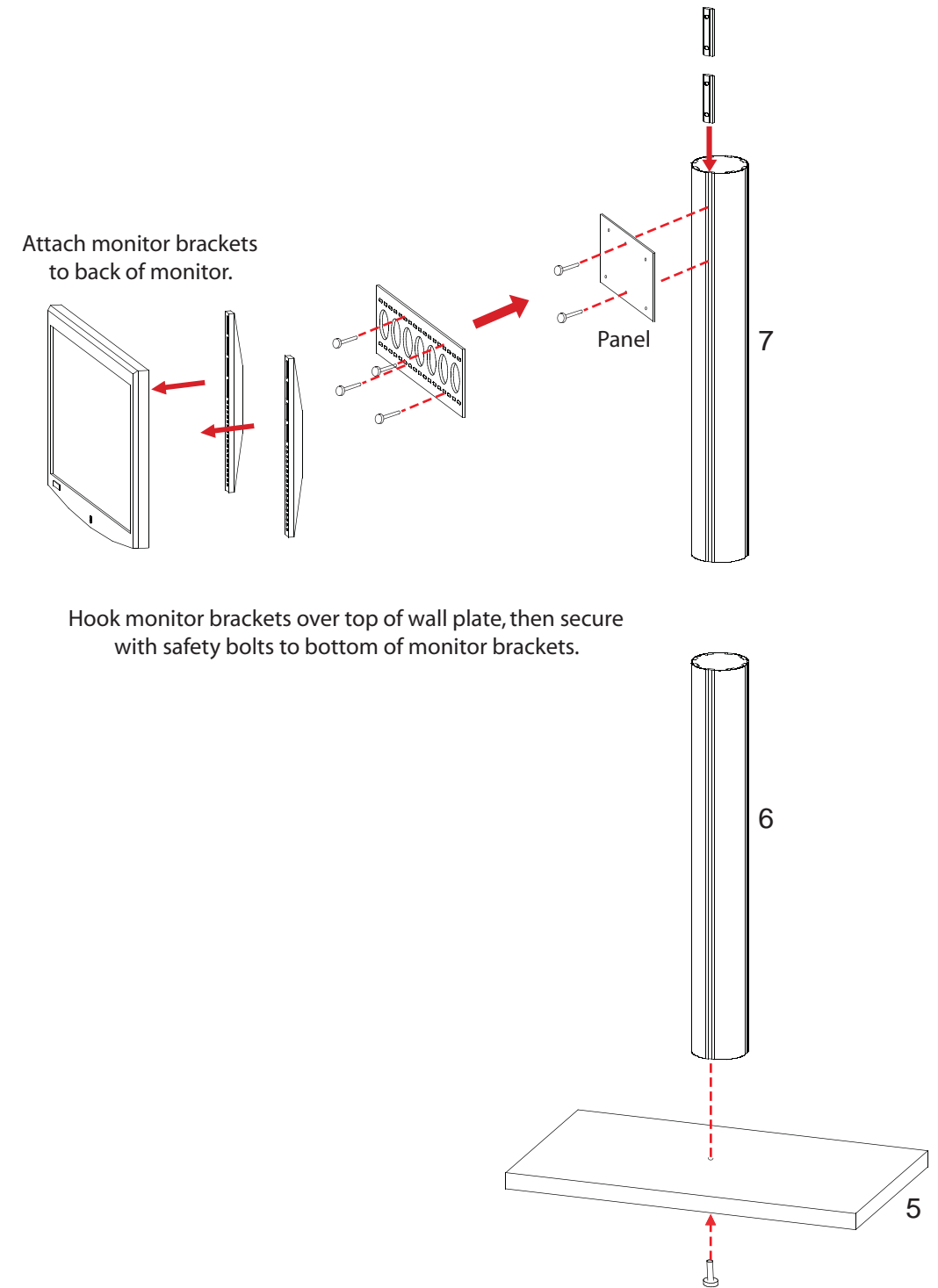

WHEN DISASSEMBLING ALUMINUM EXTRUSION, TIGHTEN ALL SETSCREWS AND LOCKS TO PREVENT LOSS DURING SHIPPING

866.652.2100

Item Number	Description
1	21" w x 30" h Flat Panel
2	30" h 90° Connector
3	21" w x 30" h Flat Panel w/ Door
4	30" h 90° Connector
5	21" w x 30" h Flat Panel
6	30" h 90° Connector
7	21" w x 30" h Flat Panel
8	30" h 90° Connector

Steps:

- 1) Assemble lower section pedestal by starting at panel #1* and continue in numerical order.
- 2) Velcro internal shelf supports to inside of assembled pedestal, then set internal shelf atop supports.
- 3) Place upper section pedestal atop assembled base.
- 4) Place counter top on assembled pedestal.

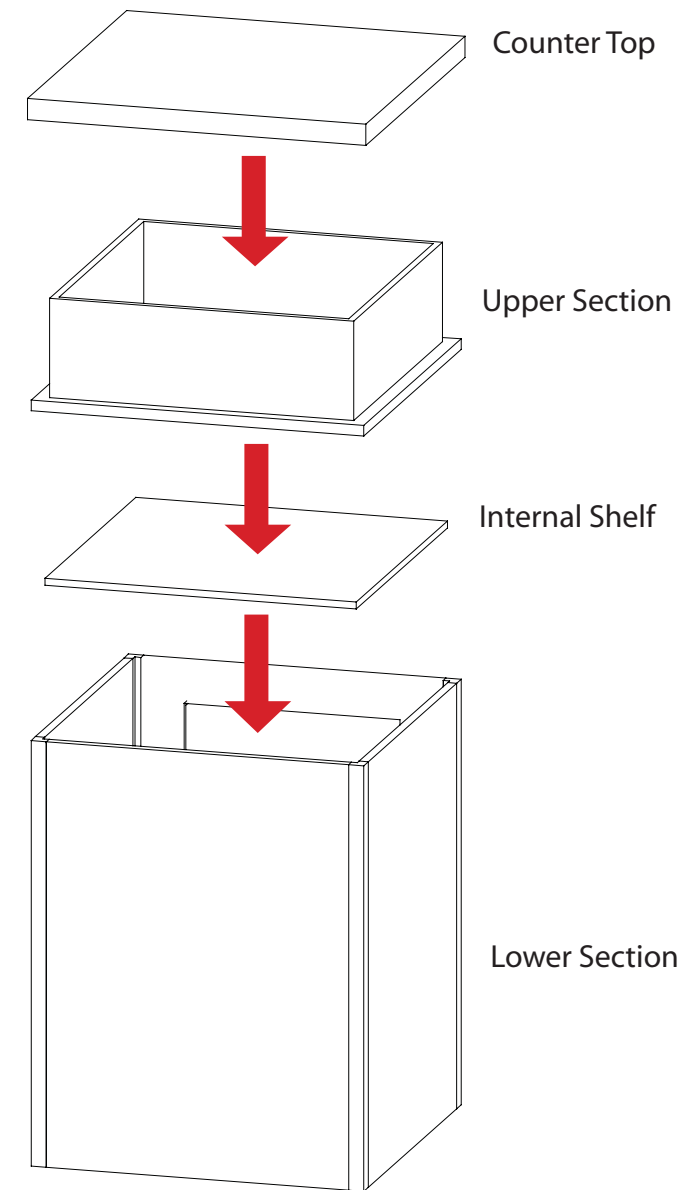
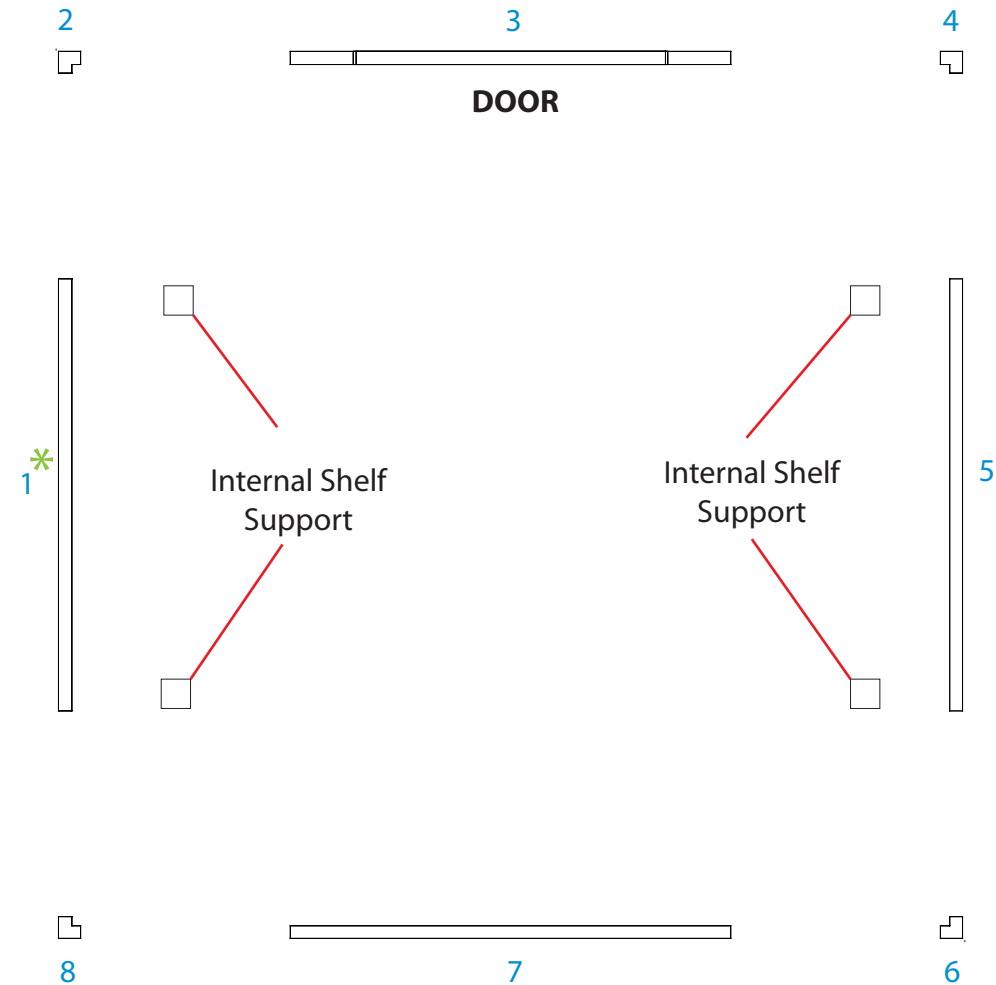
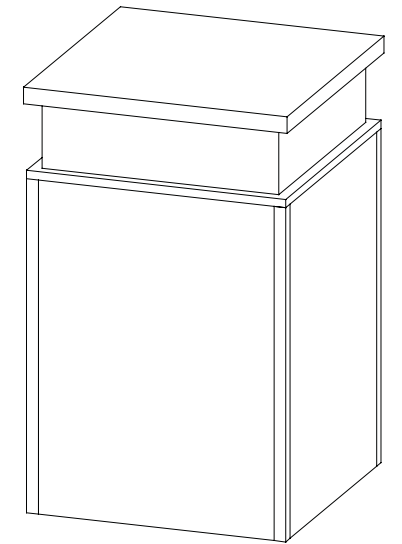

WHEN DISASSEMBLING ALUMINUM EXTRUSION, TIGHTEN ALL SETSCREWS AND LOCKS TO PREVENT LOSS DURING SHIPPING

(2) 2-Sided Graphic Frame

Monitor Stand

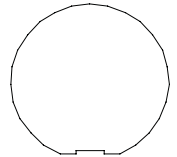

47.25"H Extrusion

Qty. : 8

Located in Case : _____

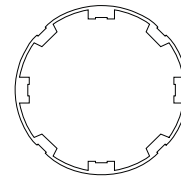

47.25"H Extrusion

Qty. : 2

Located in Case : _____



46.75"w Extrusion

Qty. : 4

Located in Case : _____

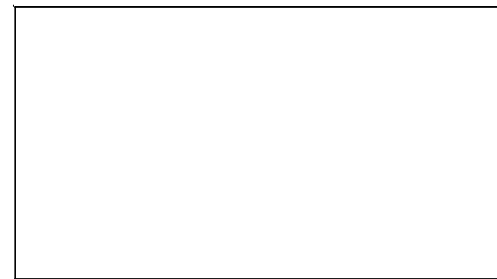

Wooden Base

Qty. : 1

Located in Case : _____

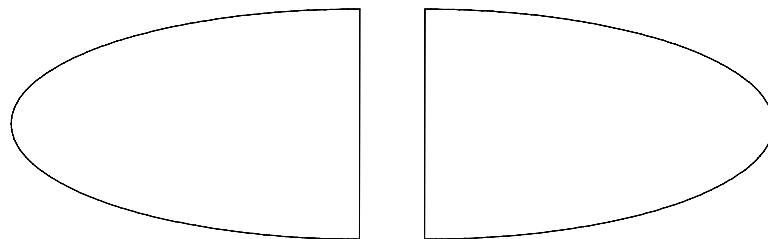

2-Piece Wooden Base

Qty. : 2

Located in Case : _____

Additional Accessories:

Setup Hardware

Located in Case _____

Located in Case _____

Located in Case _____

Located in Case _____

WHEN DISASSEMBLING ALUMINUM EXTRUSION, TIGHTEN ALL SETSCREWS AND LOCKS TO PREVENT LOSS DURING SHIPPING

866.652.2100

WHEN DISASSEMBLING ALUMINUM EXTRUSION, TIGHTEN ALL SETSCREWS AND LOCKS TO PREVENT LOSS DURING SHIPPING