

WHEN DISASSEMBLING ALUMINUM EXTRUSION, TIGHTEN ALL SETSCREWS AND LOCKS TO PREVENT LOSS DURING SHIPPING

visionary™ DESIGNS

Using Your Setup Instructions

The Visionary Designs Setup Instructions are created specifically for your configuration. They are laid out sequentially, including an exploded view of the entire display, and then a logical series of detailed steps to assemble the main structure and components. We encourage you to study the instructions **before** attempting to assemble your exhibit.

Each page reminds you to tighten the setscrews after disassembling your exhibit to prevent loss of the locks and setscrews (see below in RED). This is **VERY IMPORTANT**.

Cleaning and Packing Your Display

- 1) Use care when cleaning aluminum extrusion or acrylic inserts. Use only non-abrasive cleaners.
- 2) When cleaning laminate inserts or countertops, use mild cleansers and a soft material such as cotton.
- 3) Keep all display components away from extreme heat and long exposure to sunlight to avoid warping and fading.
- 4) Retain all packing material. It will make re-packing much easier and will reduce the likelihood of shipping damage.



The Tool

Most Visionary Designs exhibits can be assembled with the supplied Hex Key Tool. Occasionally, a flat head screwdriver may be required.

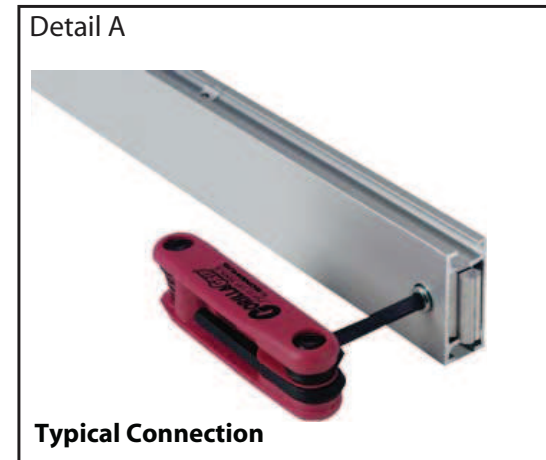

Typical Connection

Most horizontal extrusion connections have a patented expandable lock. This lock inserts into the groove of an opposing extrusion. Tightening the lock with the Hex Key Tool expands the lock and creates a strong positive connection.



Typical Connection (cont'd)

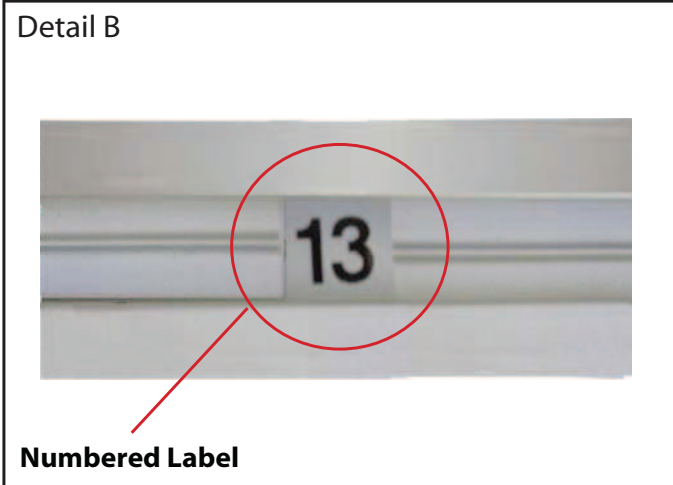

Detail B

Numbered Label

Each extrusion contains a numbered label which corresponds with setup instructions. The label is located within a groove of the extrusion (when possible). With Visionary Designs the labels contain Black numbers unless otherwise specified.



Detail C

Horizontal Inline Connection (remove only one setscrew)

Remove only (1) setscrew when disassembling. Replace setscrew in extrusion after assembling it. Before packing, replace setscrew in extrusion to avoid losing it.

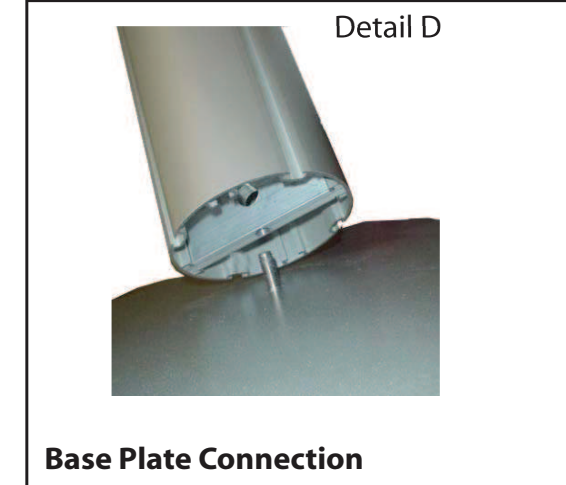

Detail D

Base Plate Connection

Attach base plate to round or square vertical extrusion using the bolt provided. Be careful not to strip the threads.

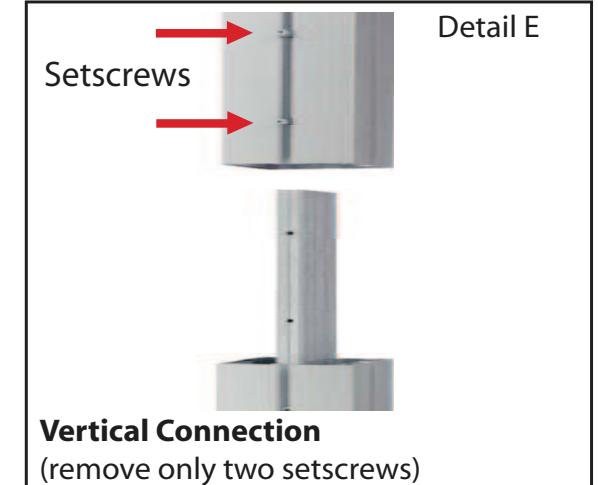

Detail E

Vertical Connection
(remove only two setscrews)

When vertical extrusions are packed in portable cases rather than crates or tubs, they must be broken down into smaller sections which then require assembly.

Remove only (2) setscrews when disassembling. Replace setscrews in extrusion after assembling it. Before packing, replace setscrews in extrusion to avoid losing them.

WHEN DISASSEMBLING ALUMINUM EXTRUSION, TIGHTEN ALL SETSCREWS AND LOCKS TO PREVENT LOSS DURING SHIPPING

866.652.2100

Item	Qty.	Description
1	4	Base Plate
2	4	84" h Vertical Extrusion
3	2	62" w Lower Horizontal Extrusion
4	2	62" w Upper Horizontal Extrusion
5	1	84" w Lower Horizontal Extrusion
6	1	84" w Upper Horizontal Extrusion

- Steps:
- 1) Attach vertical extrusions [2] to base plates [1], see detail D on general info. page.
 - 2) Connect lower and upper horizontal extrusions [3, 4, 5 and 6] between vertical extrusions [2] as shown.
 - 3) Attach lights to top of assembled backwall as shown.

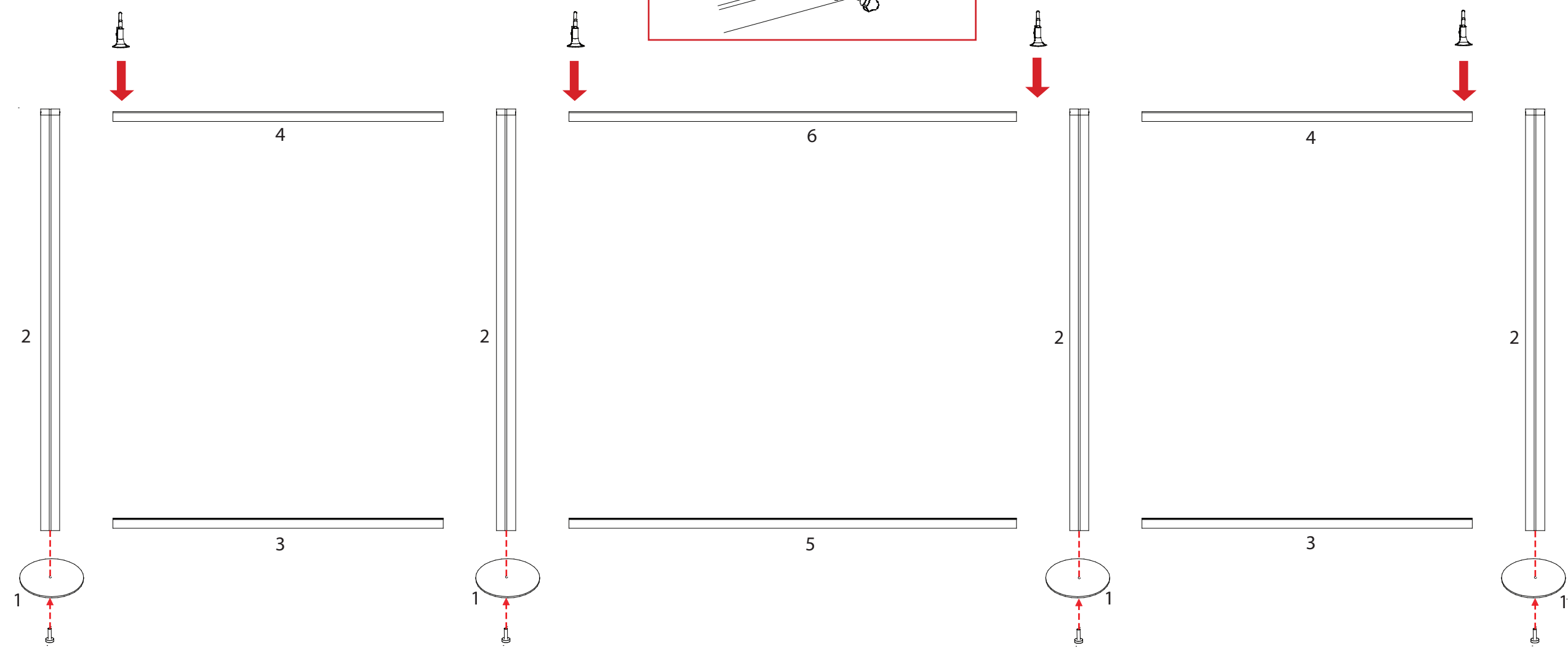
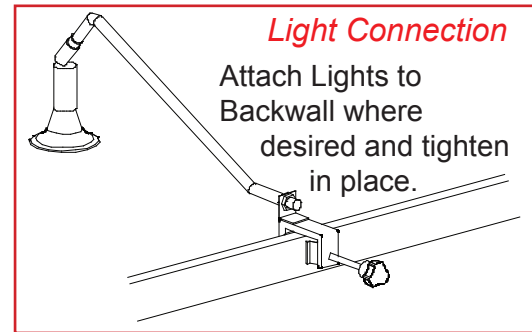
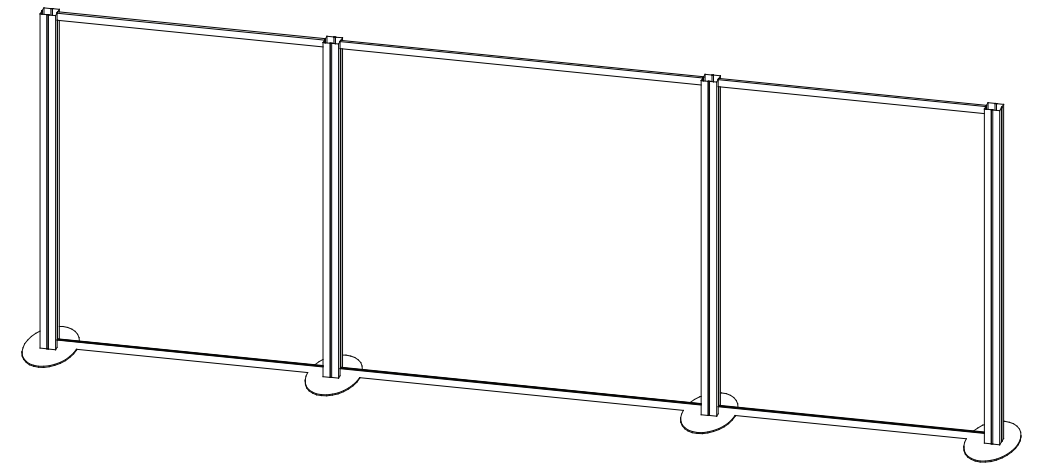

WHEN DISASSEMBLING ALUMINUM EXTRUSION, TIGHTEN ALL SETSCREWS AND LOCKS TO PREVENT LOSS DURING SHIPPING

866.652.2100

Item	Qty.	Description
7	6	35.5"h 90° Corner Extrusion
7A	2	35.5"h 90° Corner Extrusion w/ Door Stopper
7B	2	35.5"h 90° Corner Extrusion w/ Hinges
8	4	35.5"h Vertical Extrusion
9	8	8"w Horizontal Extrusion
10	4	12"w Horizontal Extrusion
11	4	31.1718"w Curved Horizontal Extrusion
12	4	30"w Horizontal Extrusion
13	4	19.509"w Horizontal Extrusion
14	4	22.659"w Horizontal Extrusion

- Steps:
- 1) Attach lower horizontal extrusions [9, 10, 11, 12, 13 and 14] between vertical extrusions [7, 7A, 7B and 8] as shown.
 - 2) Attach extrusion door between vertical extrusions [7A and 7B], see door attachment detail.
 - 3) Attach upper horizontal extrusions [9, 10, 11, 12, 13 and 14] between vertical extrusions [7, 7A, 7B and 8] as shown.

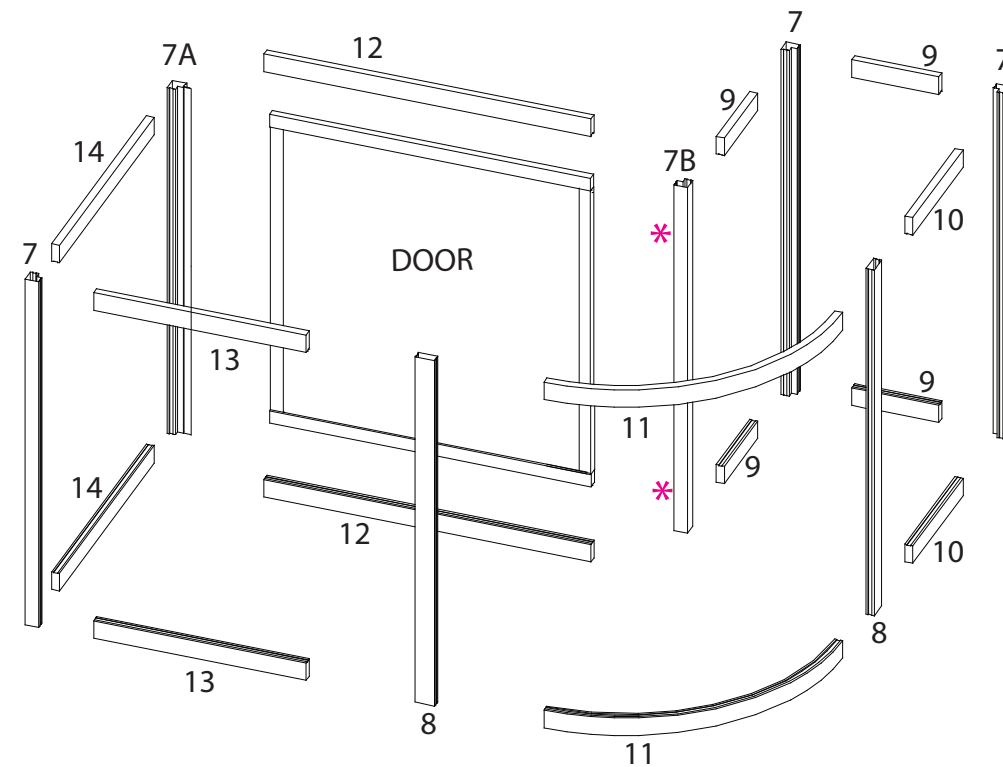
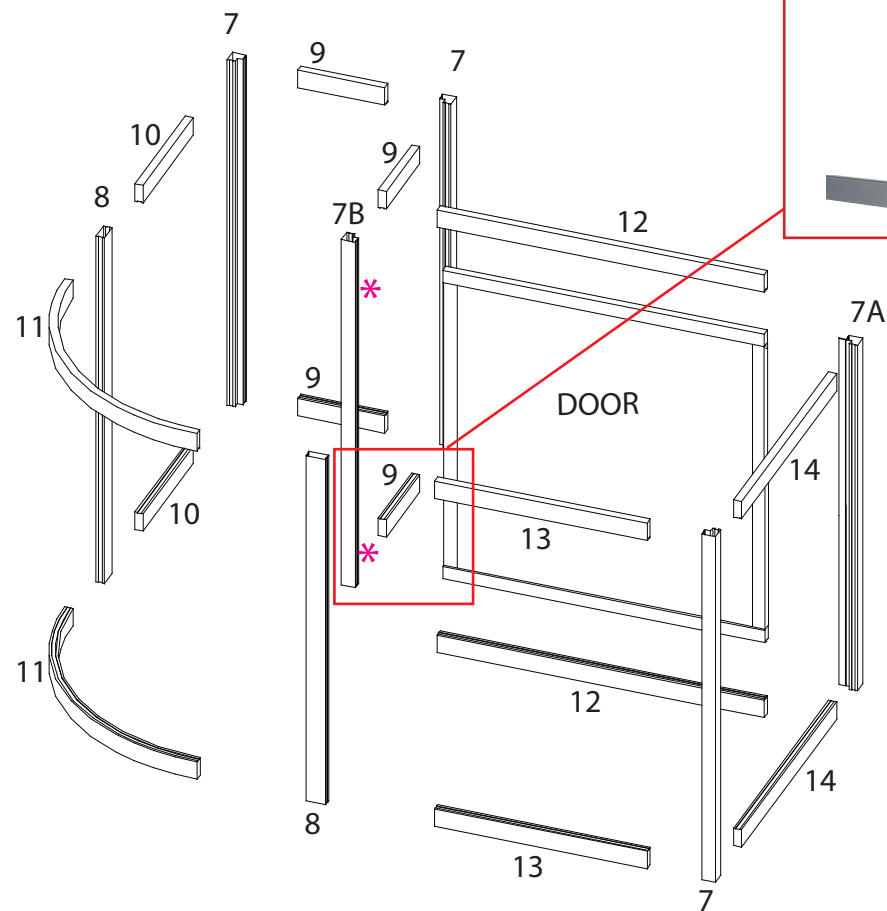
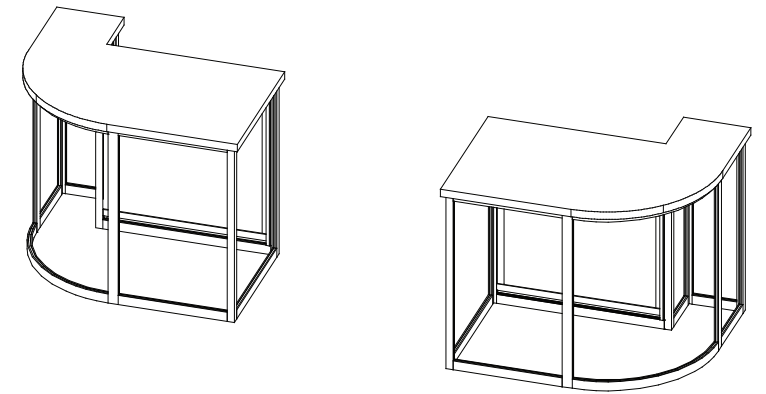

* = Hinge Location

Place counter atop assembled pedestal.

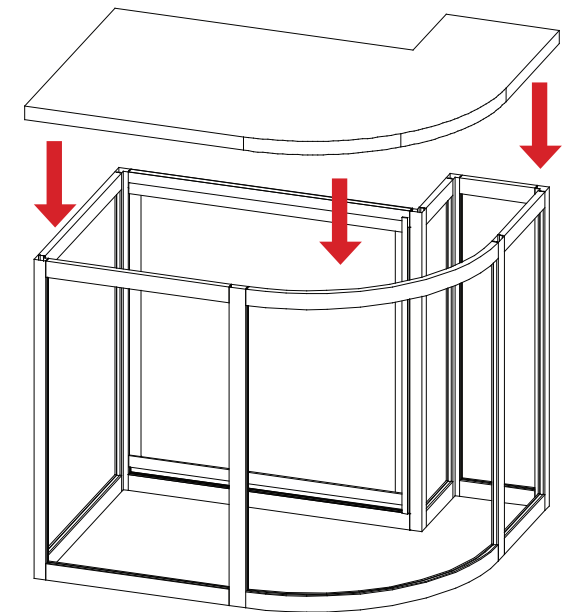

** Repeat for 2nd pedestal.

WHEN DISASSEMBLING ALUMINUM EXTRUSION, TIGHTEN ALL SETSCREWS AND LOCKS TO PREVENT LOSS DURING SHIPPING

866.652.2100

Item	Qty.	Description
15	6	47.5"h 90° Corner Extrusion
16	4	47.5"h Vertical Extrusion
17	4	10"w Horizontal Extrusion
18	4	20"w Horizontal Extrusion
19	4	31.1718"w Curved Horizontal Extrusion
20	2	37.475"w Horizontal Extrusion
21	4	28.6586"w Horizontal Extrusion
22	2	54.457"w Horizontal Extrusion

- Steps:
- 1) Attach horizontal extrusions [17 thru 22] between vertical extrusions [15 and 16] as shown in illustration.
 - 2) Place counter top on assembled base.

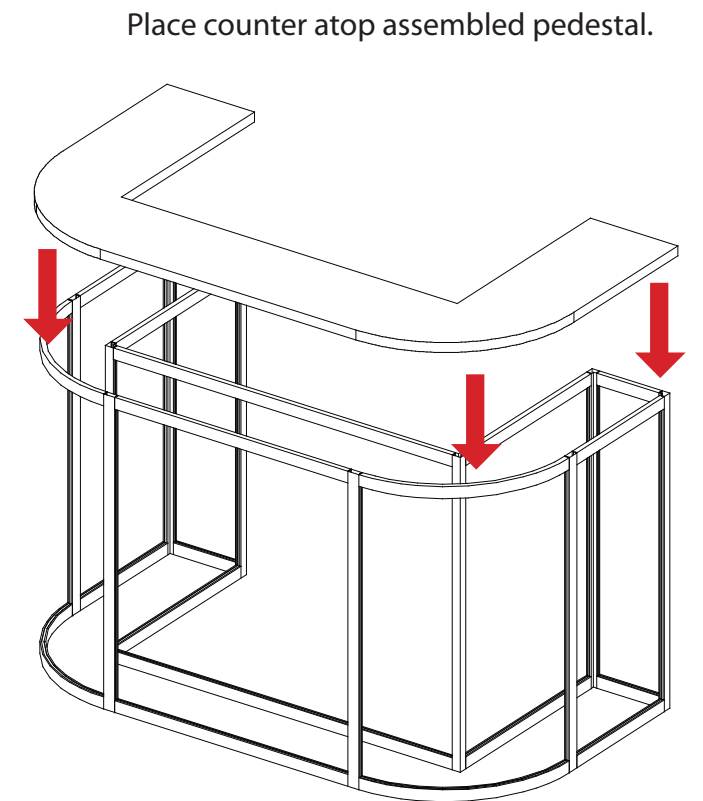
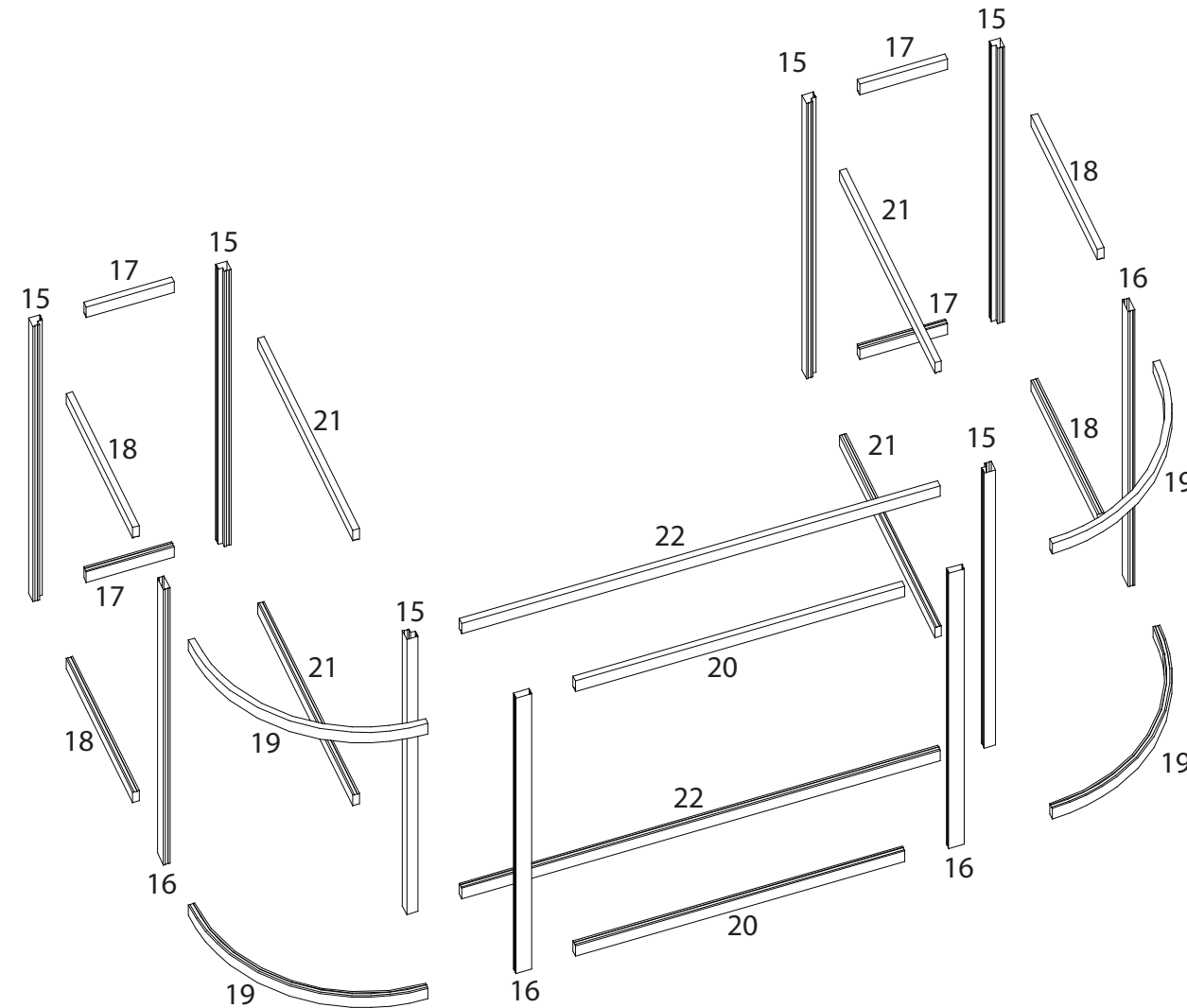
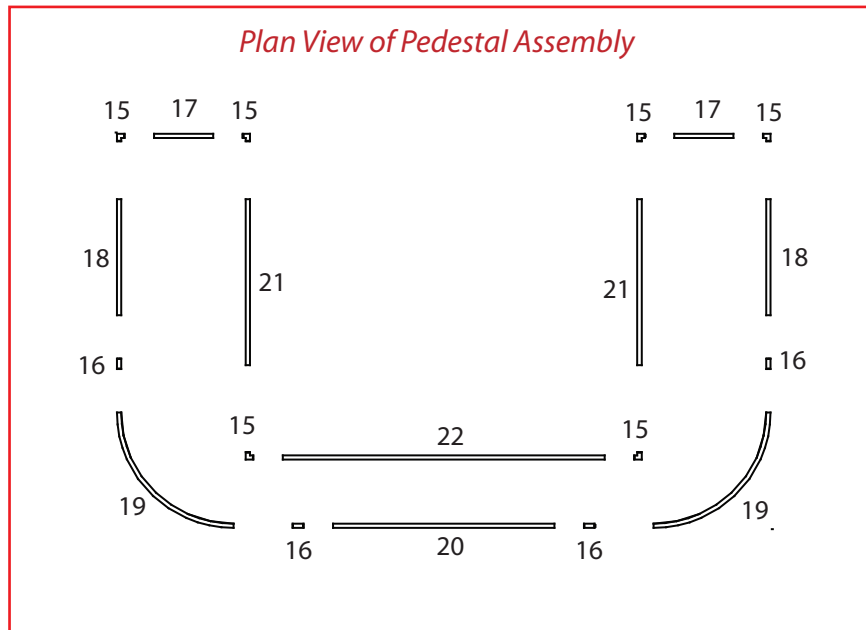
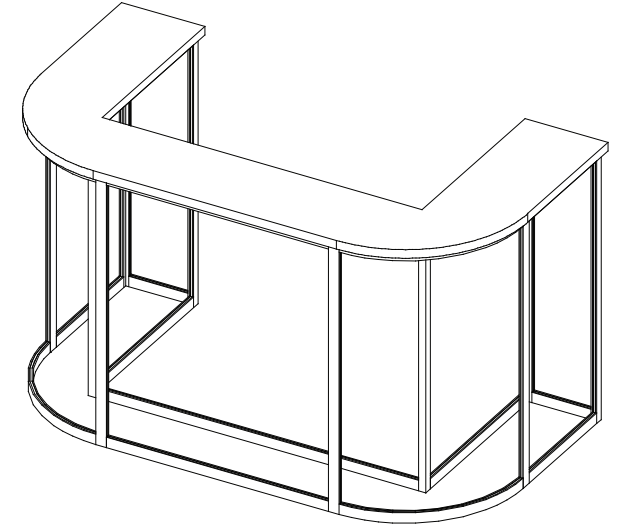

WHEN DISASSEMBLING ALUMINUM EXTRUSION, TIGHTEN ALL SETSCREWS AND LOCKS TO PREVENT LOSS DURING SHIPPING

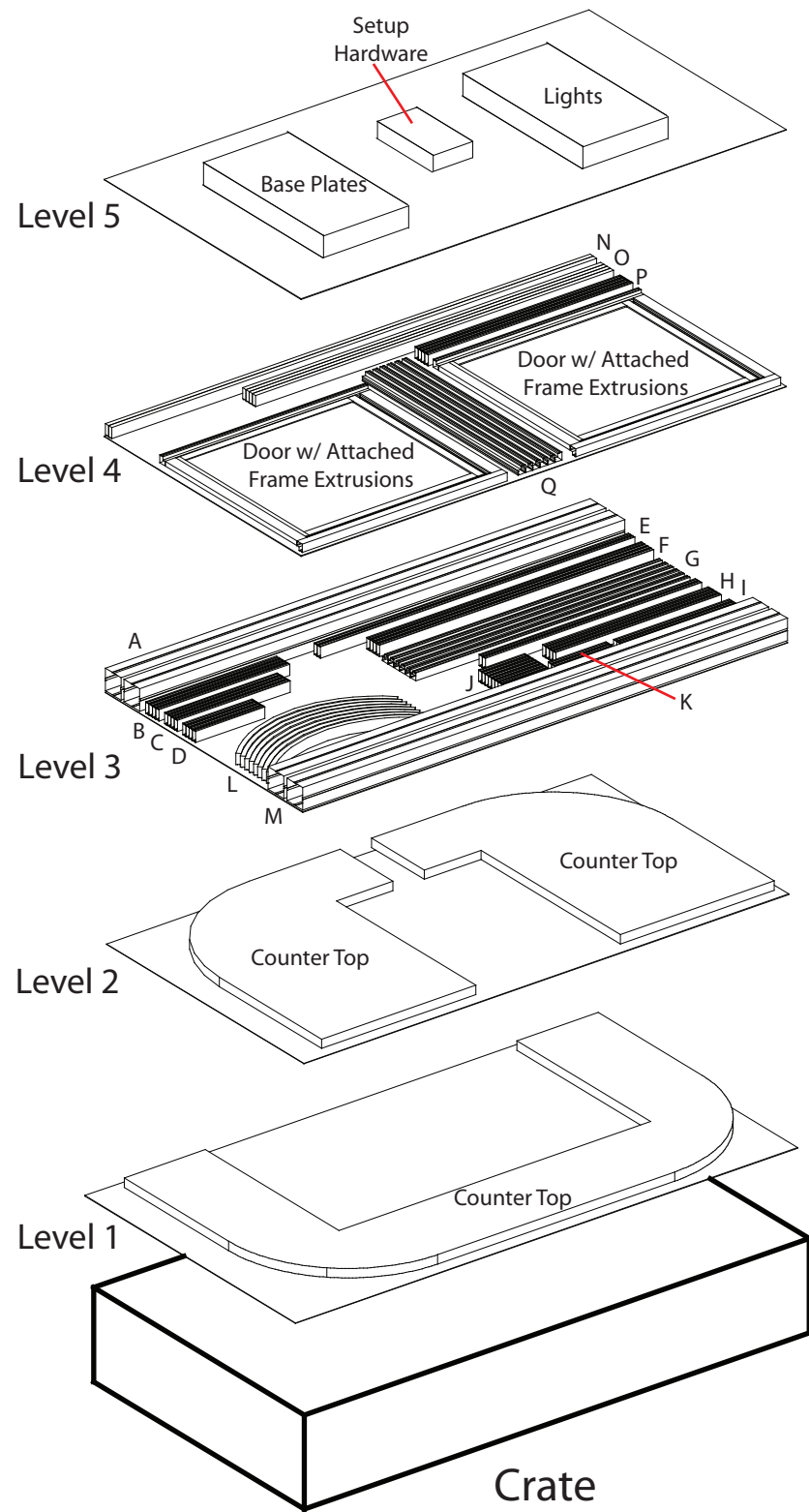

- Part List:
- A - (2) 84" Square Extrusion
 - B - (4) 22.659" Extrusion
 - C - (4) 19.509" Extrusion
 - D - (4) 12" Extrusion
 - E - (2) 54.457 Extrusion
 - F - (4) 47.5" Extrusion
 - G - (6) 47.5" 90° Corner Extrusion
 - H - (2) 37.475" Extrusion
 - I - (4) 28.659" Extrusion
 - J - (8) 8" Extrusion
 - K - (4) 10" Extrusion
 - L - (8) 31.1718" Curved Extrusion
 - M - (2) 84" Square Extrusion
 - N - (2) 84" Extrusion
 - O - (4) 62" Extrusion
 - P - (4) 35.5" Extrusion
 - Q - (6) 35.5" 90° Corner Extrusion

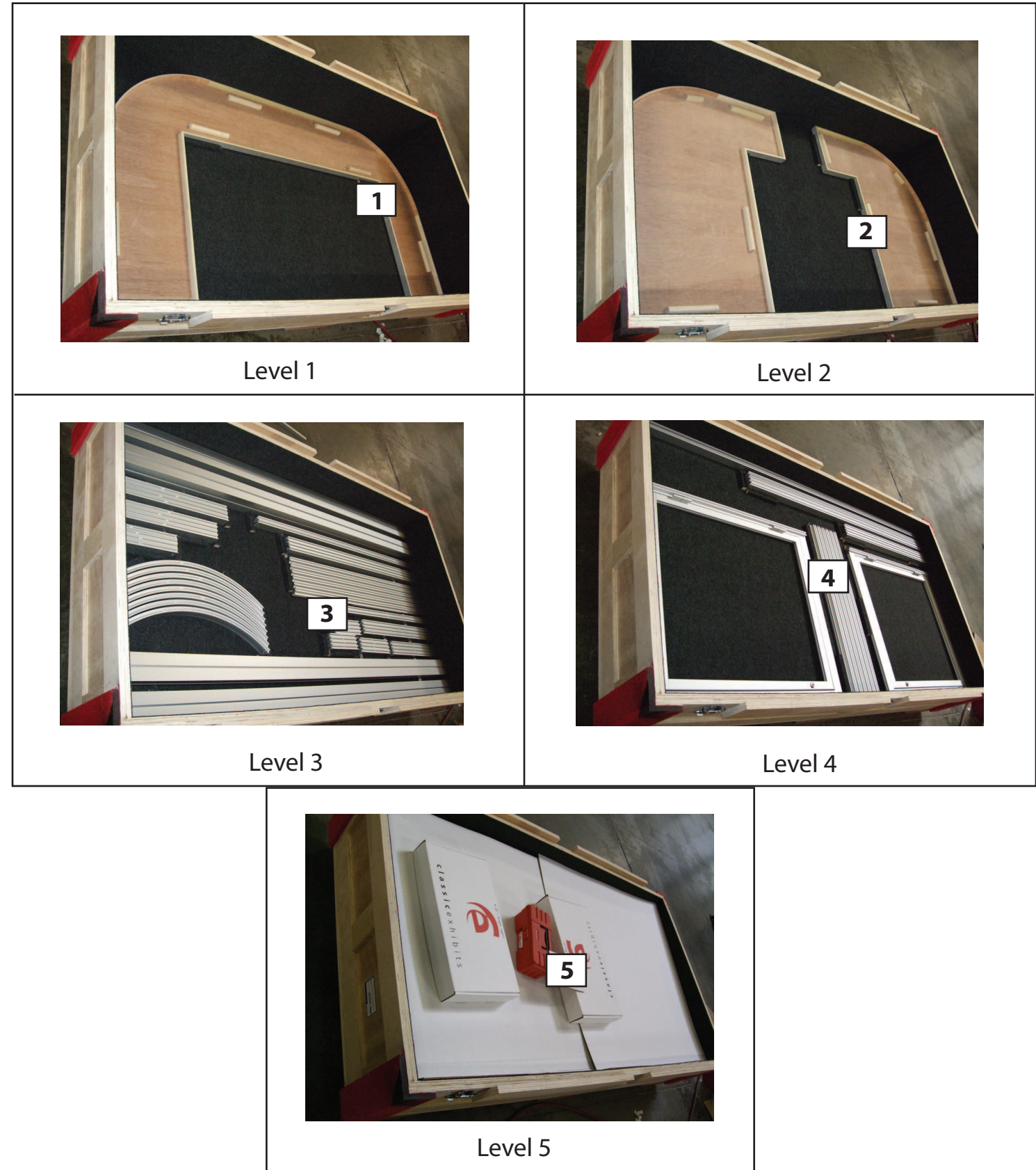

WHEN DISASSEMBLING ALUMINUM EXTRUSION, TIGHTEN ALL SETSCREWS AND LOCKS TO PREVENT LOSS DURING SHIPPING