

WHEN DISASSEMBLING ALUMINUM EXTRUSION, TIGHTEN ALL SETSCREWS AND LOCKS TO PREVENT LOSS DURING SHIPPING

visionary™ DESIGNS

Using Your Setup Instructions

The Visionary Designs Setup Instructions are created specifically for your configuration. They are laid out sequentially, including an exploded view of the entire display, and then a logical series of detailed steps to assemble the main structure and components. We encourage you to study the instructions **before** attempting to assemble your exhibit.

Each page reminds you to tighten the setscrews after disassembling your exhibit to prevent loss of the locks and setscrews (see below in RED). This is **VERY IMPORTANT**.

Cleaning and Packing Your Display

- 1) Use care when cleaning aluminum extrusion or acrylic inserts. Use only non-abrasive cleaners.
- 2) When cleaning laminate inserts or countertops, use mild cleansers and a soft material such as cotton.
- 3) Keep all display components away from extreme heat and long exposure to sunlight to avoid warping and fading.
- 4) Retain all packing material. It will make re-packing much easier and will reduce the likelihood of shipping damage.



The Tool

Most Visionary Designs exhibits can be assembled with the supplied Hex Key Tool. Occasionally, a flat head screwdriver may be required.



Detail A

Typical Connection



Typical Connection (cont'd)

Most horizontal extrusion connections have a patented expandable lock. This lock inserts into the groove of an opposing extrusion. Tightening the lock with the Hex Key Tool expands the lock and creates a strong positive connection.

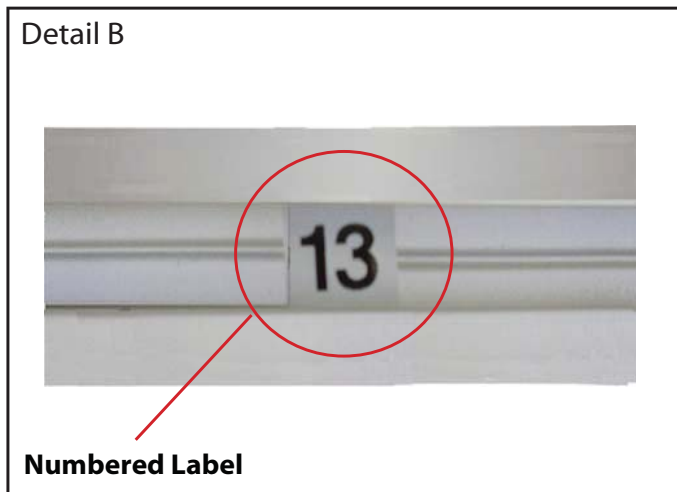

Detail B

Numbered Label

Each extrusion contains a numbered label which corresponds with setup instructions. The label is located within a groove of the extrusion (when possible). With Visionary Designs the labels contain Black numbers unless otherwise specified.



Detail C

Horizontal Inline Connection (remove only one setscrew)

Remove only (1) setscrew when disassembling. Replace setscrew in extrusion after assembling it. Before packing, replace setscrew in extrusion to avoid losing it.

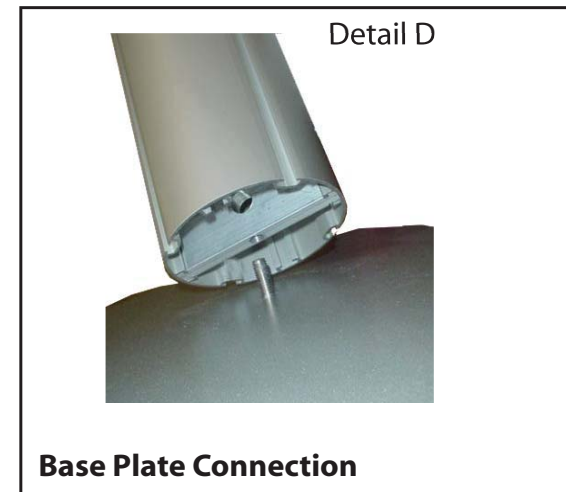

Detail D

Base Plate Connection

Attach base plate to round or square vertical extrusion using the bolt provided. Be careful not to strip the threads.

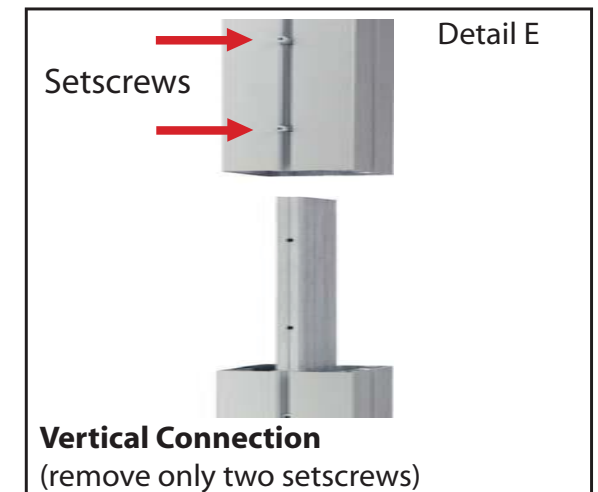

Detail E

Vertical Connection
(remove only two setscrews)

When vertical extrusions are packed in portable cases rather than crates or tubs, they must be broken down into smaller sections which then require assembly.

Remove only (2) setscrews when disassembling. Replace setscrews in extrusion after assembling it. Before packing, replace setscrews in extrusion to avoid losing them.

WHEN DISASSEMBLING ALUMINUM EXTRUSION, TIGHTEN ALL SETSCREWS AND LOCKS TO PREVENT LOSS DURING SHIPPING

Part Number	Qty for Step	Description
1	4	96" Vertical extrusion
2	3	63.5" Horizontal w/ Velcro attached to extrusion
3	2	63.5" Horizontal extrusion
4	2	40.25" Curved Horizontal extrusion
5	1	63.5" Horizontal extrusion w/ Mount Location
5A	1	63.5" Horizontal w/ Mount Location and Velcro attached to extrusion

Note: Attaching Graphics

Attach Backwall Graphics to Velcro placed on the Top Front Edge of the Upper Horizontals [2 and 5A] and on the Bottom Front Edge of the Lower Horizontals [2].

Steps

- 1) Connect horizontal extrusions [2 and 3] between vertical extrusions [1], placing inserts where indicated.
- 2) Connect curved horizontal extrusions [4] between vertical extrusions [1], placing inserts where indicated.
- 3) Connect horizontal extrusions [2, 3, 5 and 5A] between vertical extrusions [1], placing inserts where indicated.

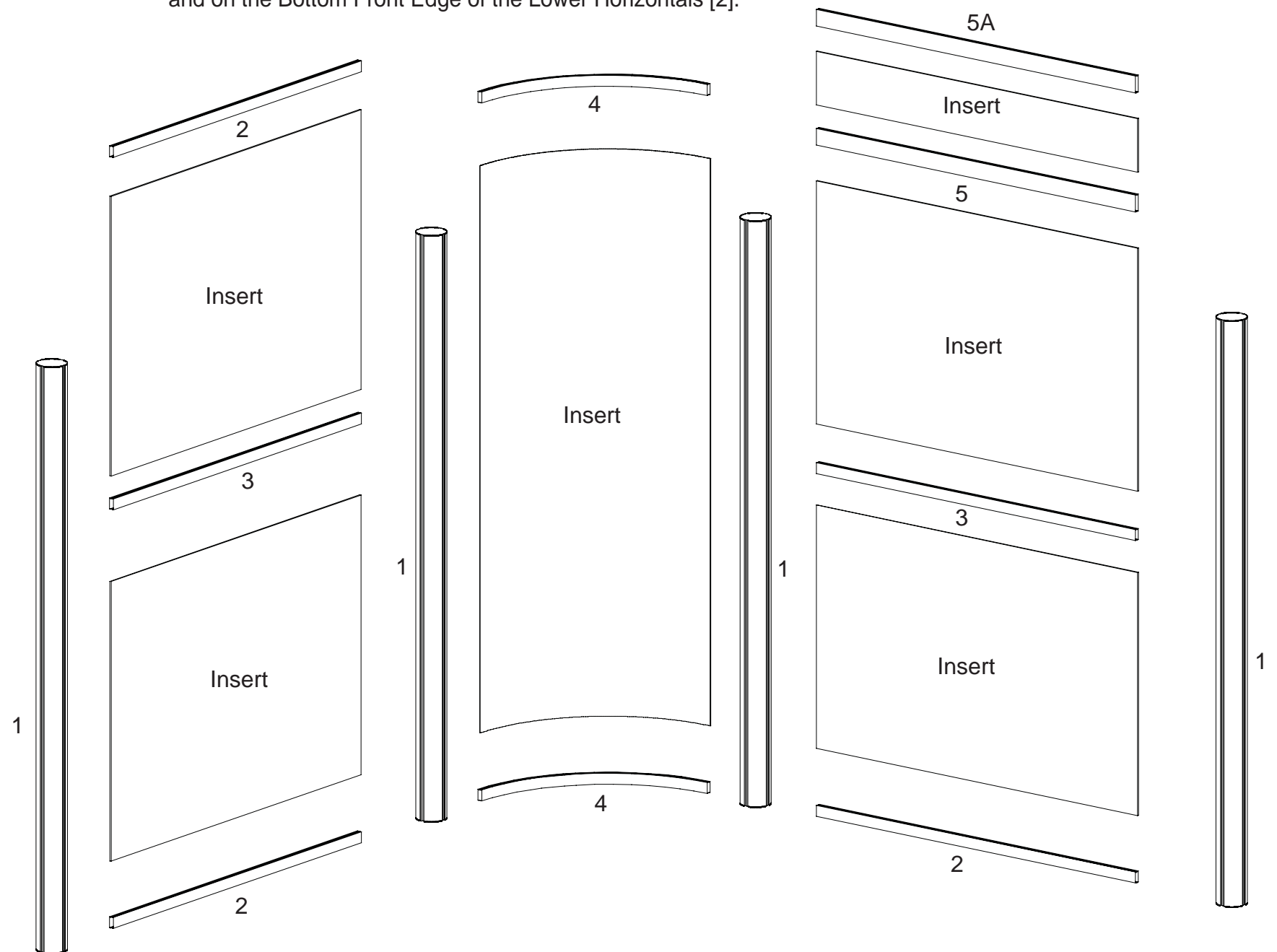

WHEN DISASSEMBLING ALUMINUM EXTRUSION, TIGHTEN ALL SETSCREWS AND LOCKS TO PREVENT LOSS DURING SHIPPING

866.652.2100

Part Number	Qty for Step	Description
1	4	96" Vertical extrusion
2	2	63.5" Horizontal w/ Velcro attached to extrusion
3	1	63.5" Horizontal extrusion
4	6	40.25" Curved Horizontal extrusion
6	2	10.959" Horizontal extrusion
7	1	73.6689" Vertical extrusion w/ Door Hinges
8	1	73.6689" Vertical extrusion w/ Door Stop
9	1	63.5" Horizontal extrusion
10	1	63.5" Horizontal extrusion w/ Mount Location
10A	1	63.5" Horizontal w/ Mount Location

Steps

- 1) Connect curved horizontal extrusions [4] between vertical extrusions [1], placing inserts where indicated.
- 2) Connect horizontal extrusions [2 and 3] between vertical extrusions [1], placing inserts where indicated.
- 3) Connect curved horizontal extrusions [4] between vertical extrusions [1], placing inserts where indicated.
- 4) Connect horizontal extrusions [6] between vertical extrusions [1 and 7 then between 1 and 8], placing inserts where indicated.
- 5) Connect horizontal extrusion [9] between vertical extrusions [1] and atop extrusions [7 and 8].
- 6) Connect horizontal extrusions [10 and 10A] between vertical extrusions [1], placing inserts where indicated.
- 7) Insert door atop hinges as indicated.

Note: Attaching Graphics
 Attach Backwall Graphics to Velcro placed on the Top Front Edge of the Upper Horizontal [2] and on the Bottom Front Edge of the Lower Horizontal [2].

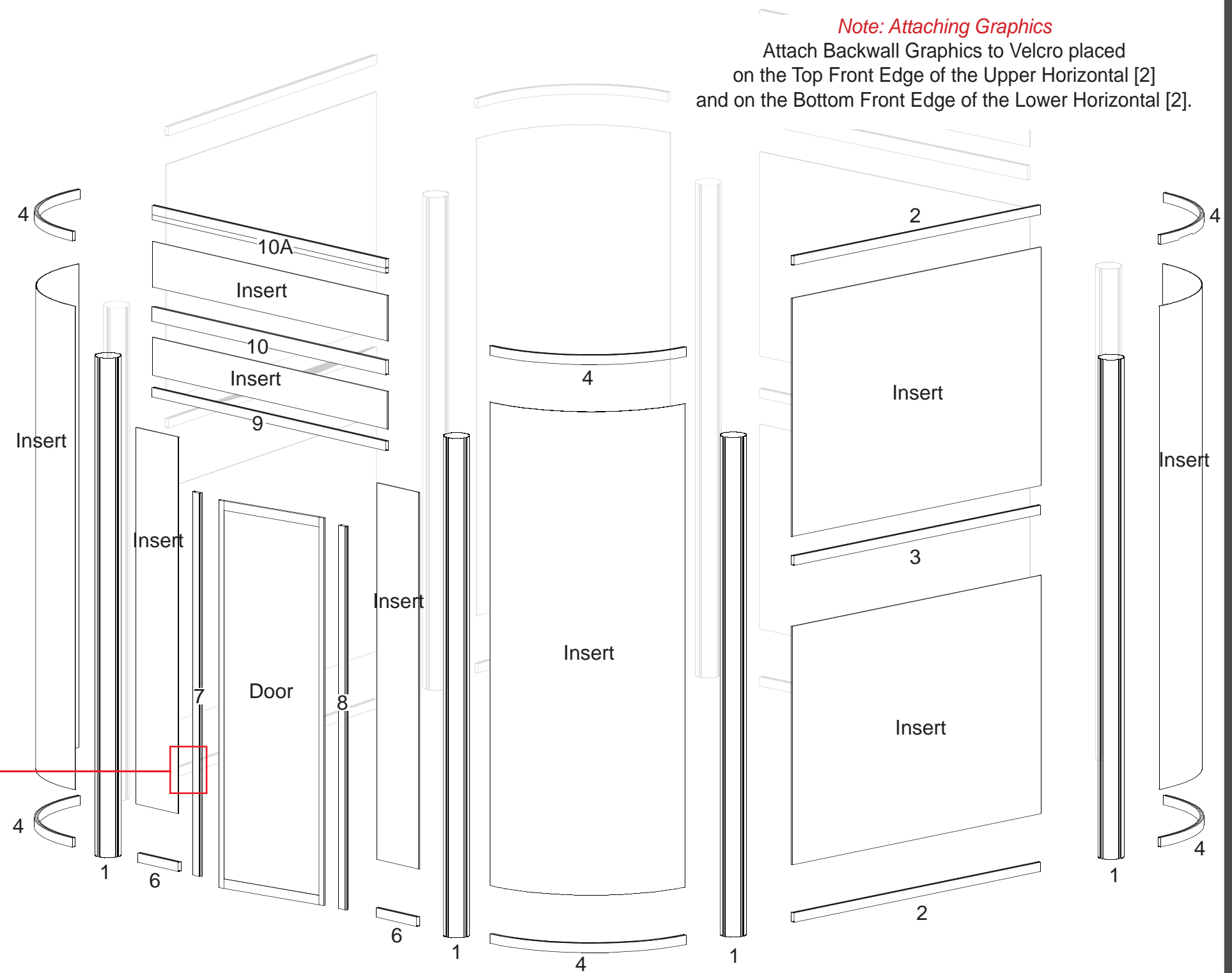
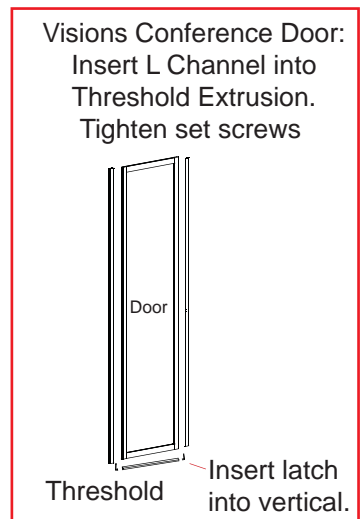

WHEN DISASSEMBLING ALUMINUM EXTRUSION, TIGHTEN ALL SETSCREWS AND LOCKS TO PREVENT LOSS DURING SHIPPING



866.652.2100

Using Your Setup Instructions

The Aero Overhead Sign Setup Instructions are created specifically for your configuration. They include an exploded view of the frame which is sequentially numbered. We encourage you to study the instructions before attempting to assemble your exhibit.

Connections are kept very simple: no tools. Everything assembles with push-button connectors and pre-connected horizontal sections.

Cleaning and Packing Your Display

- 1) Use care when cleaning aluminum extrusion or acrylic inserts. Use only non-abrasive cleaners.
- 2) Retain all packing material. It will make re-packing much easier and will reduce the likelihood of shipping damage.

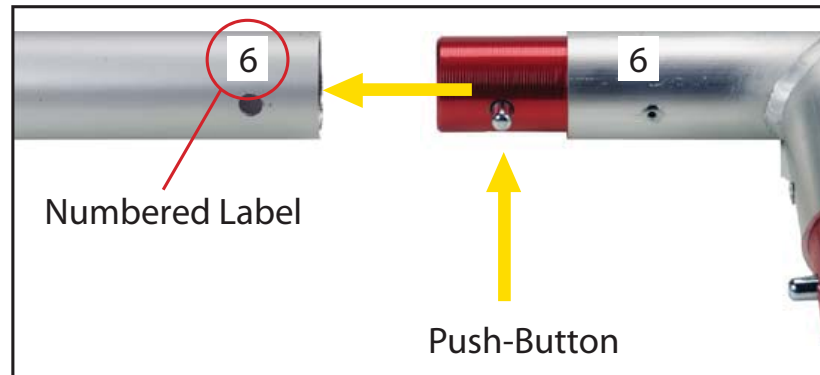
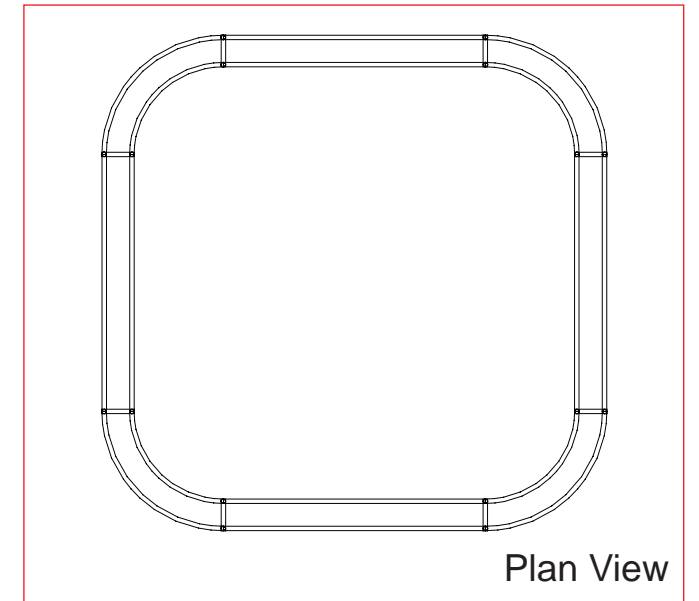

Connections are made by holding the button down and sliding the red tube into opposing tube until the connection is made. To disassemble push button and pull or twist extrusions apart.

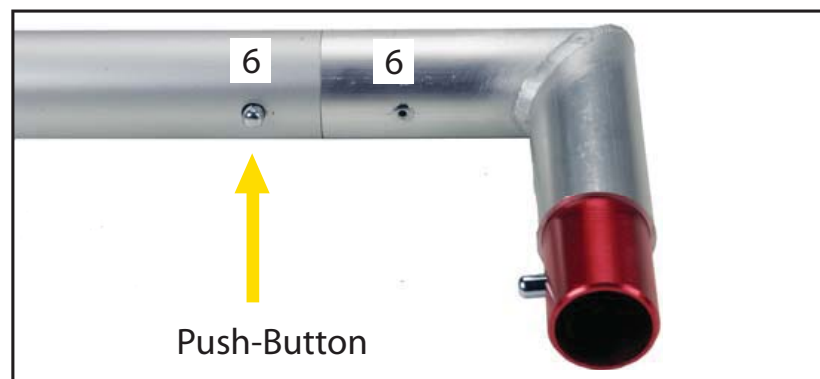

Steps:

- 1) Connect all pieces together in numerical order.

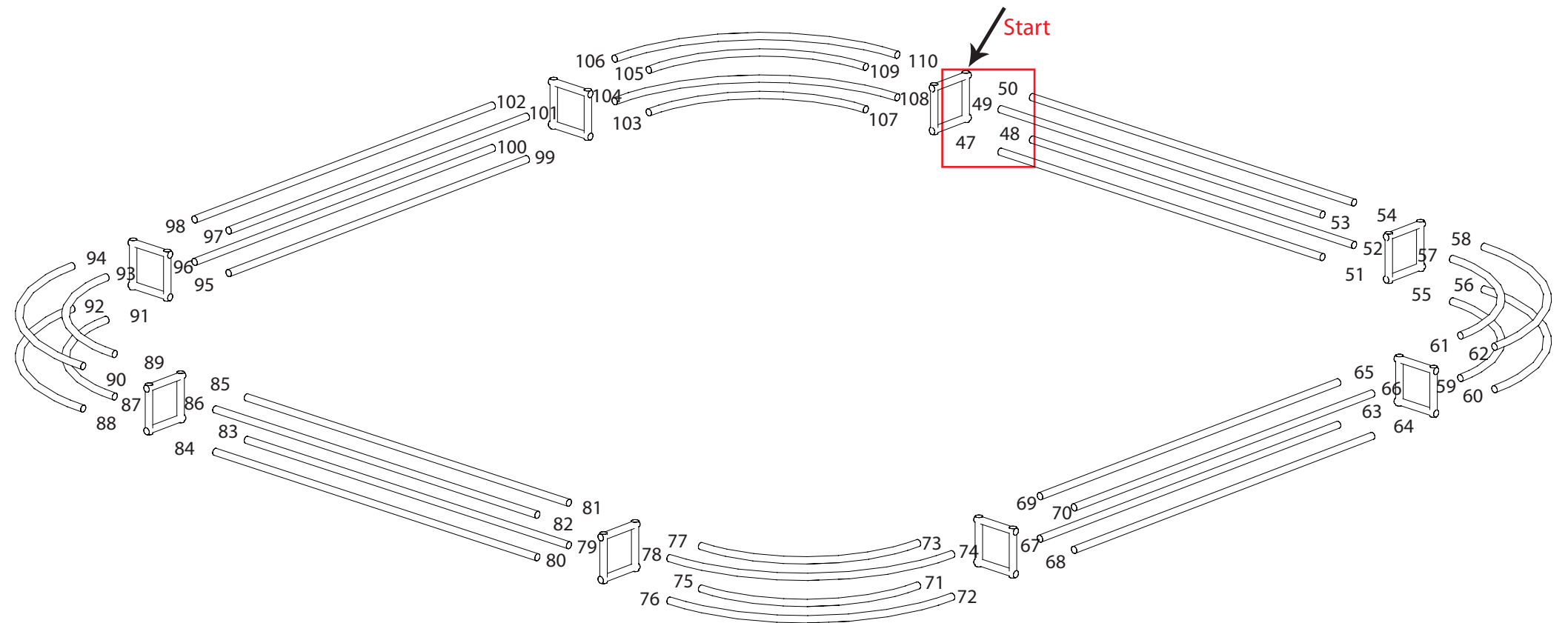

WHEN DISASSEMBLING ALUMINUM EXTRUSION, TIGHTEN ALL SETSCREWS AND LOCKS TO PREVENT LOSS DURING SHIPPING

866.652.2100

Part Number	Qty for Step	Description
22	2	96"h Vertical extrusion
22A	2	Cap with Aero Frame Connection
23	3	42"h Vertical extrusion
23A	12	12" Horizontal extrusion for shelf support
24	2	42"h Vertical extrusion
25	18	23.6373" Curved Horizontal extrusion
25A	8	Counter Support extrusion

Steps

- 1) Connect lower curved horizontal extrusions [25] between vertical extrusions [22, 23 and 24], placing inserts where indicated.
- 2) Connect middle curved horizontal extrusions [25] between vertical extrusions [22, 23 and 24] and atop inserts.
- 3) Connect upper curved horizontal extrusions [25] between vertical extrusions [22, 23 and 24] flush with tops of vertical extrusions [23 and 24].
- 4) Connect horizontal extrusions [25A] to vertical extrusions [22, 23 and 24] as shown below for counter support.
- 5) Connect horizontal extrusions [23A] to vertical extrusions [22, 23 and 24] at desired locations for shelves.
- 6) Place shelves in place and attach to supports using stand-off caps provided.

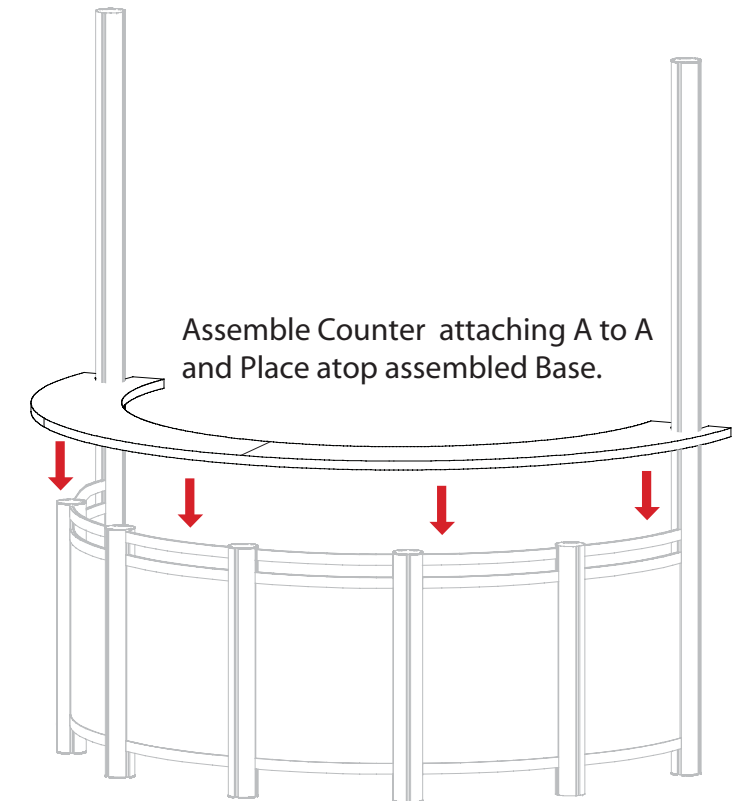
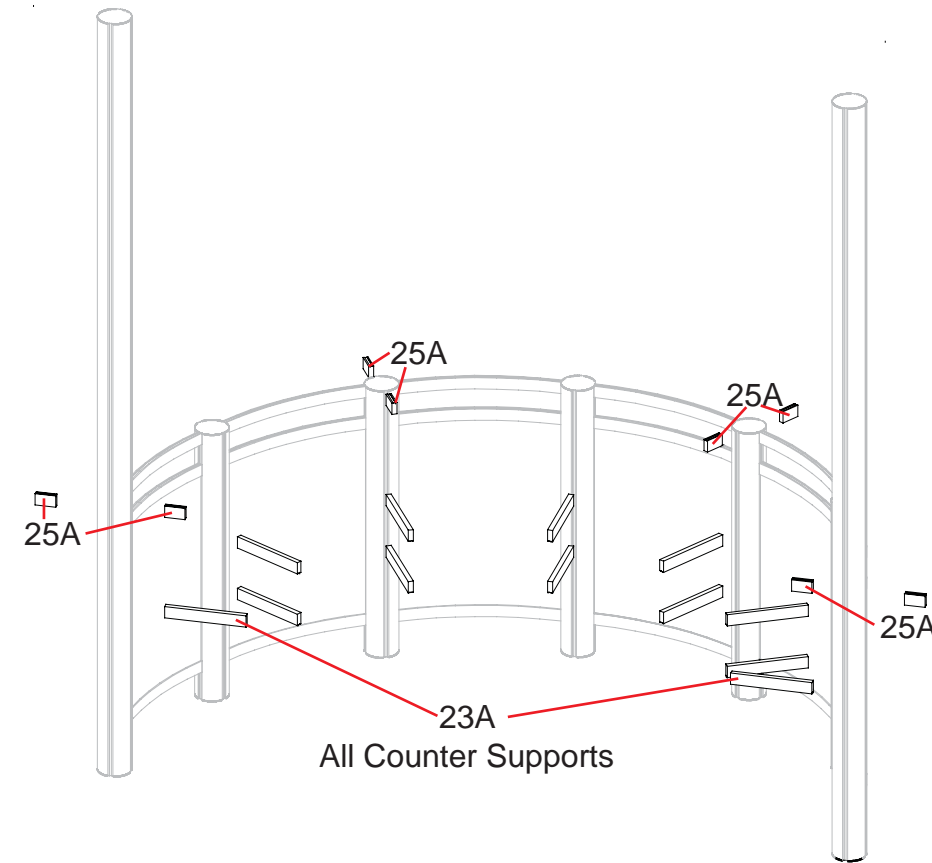
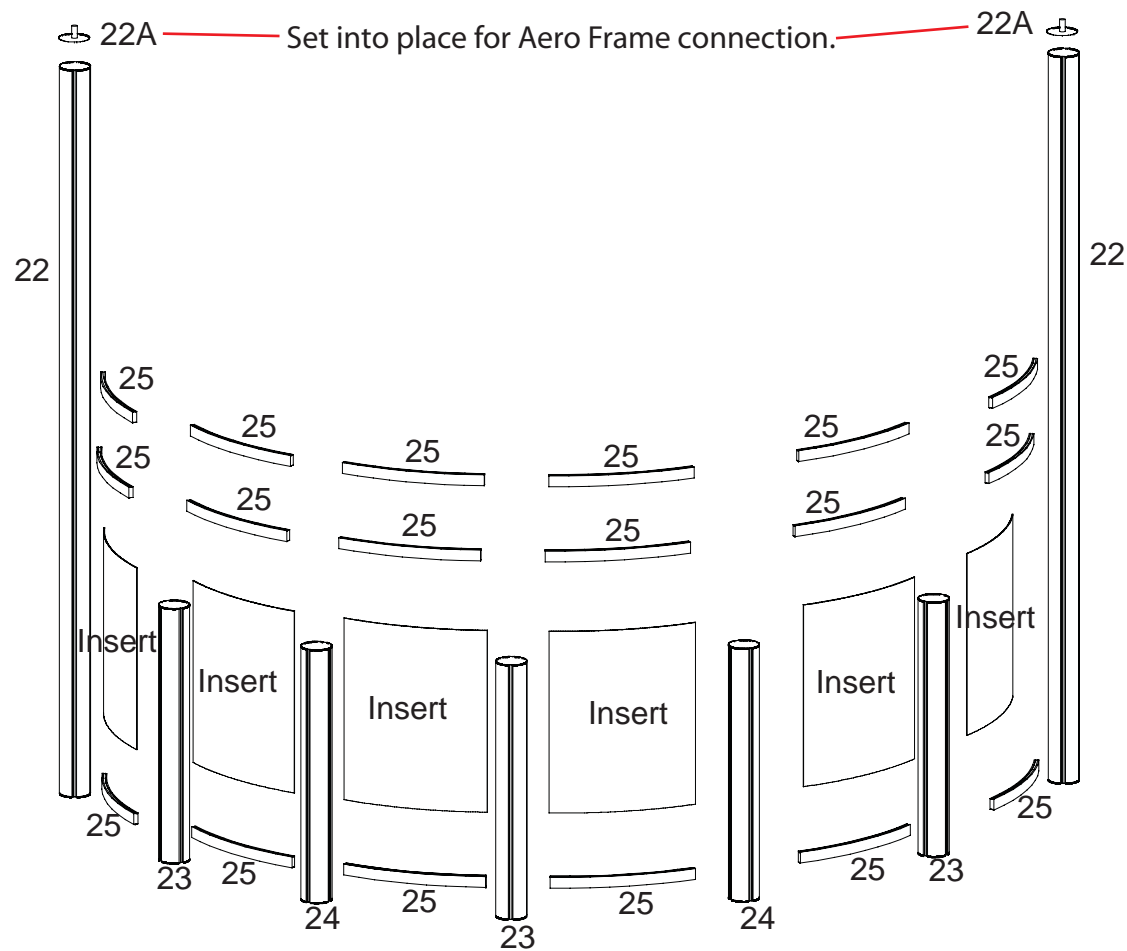
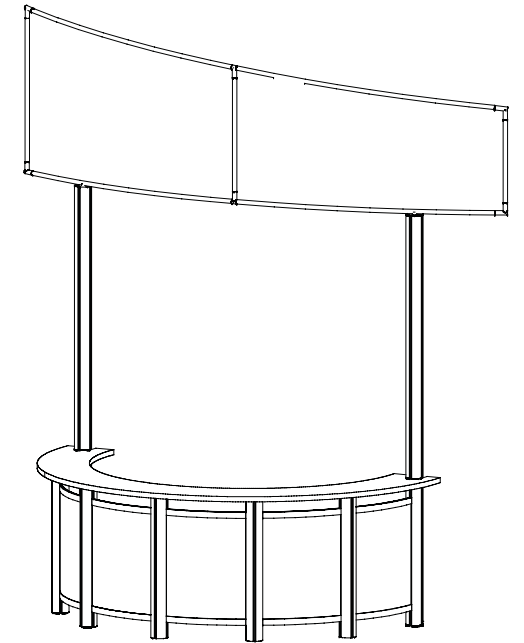

WHEN DISASSEMBLING ALUMINUM EXTRUSION, TIGHTEN ALL SETSCREWS AND LOCKS TO PREVENT LOSS DURING SHIPPING



866.652.2100

Using Your Setup Instructions

The Aero Overhead Sign Setup Instructions are created specifically for your configuration. They include an exploded view of the frame which is sequentially numbered. We encourage you to study the instructions before attempting to assemble your exhibit.

Connections are kept very simple: no tools. Everything assembles with push-button connectors and pre-connected horizontal sections.

Cleaning and Packing Your Display

- 1) Use care when cleaning aluminum extrusion or acrylic inserts. Use only non-abrasive cleaners.
- 2) Retain all packing material. It will make re-packing much easier and will reduce the likelihood of shipping damage.

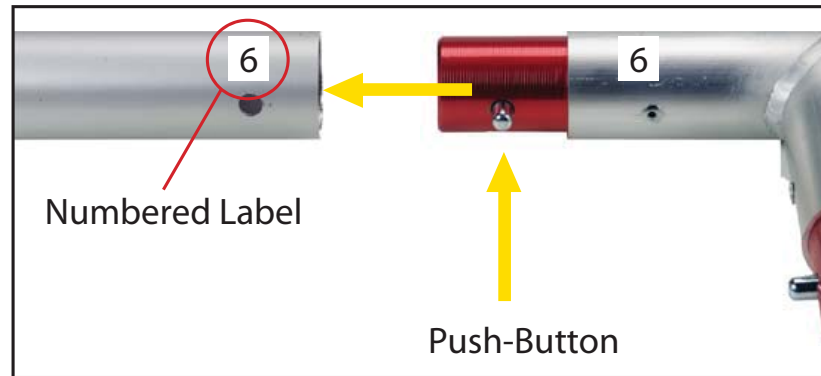
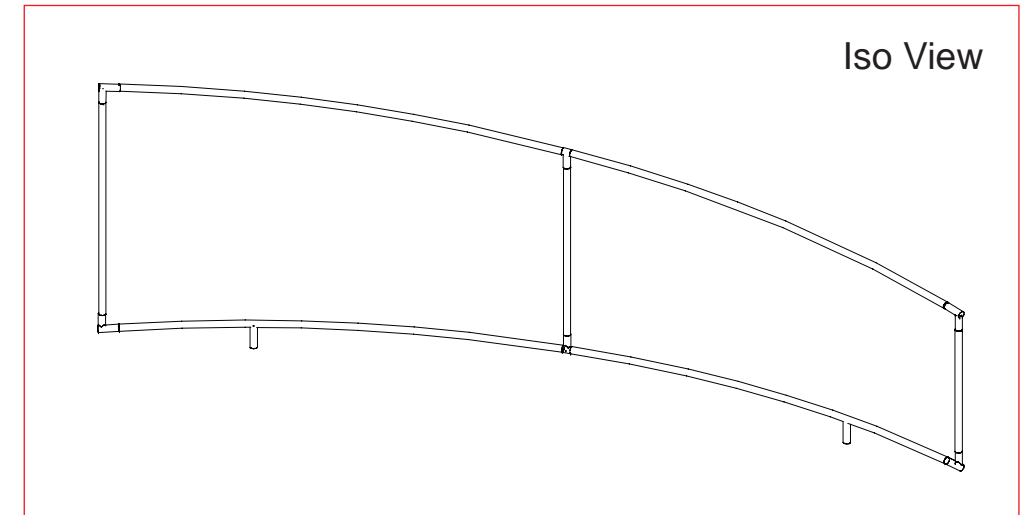

Connections are made by holding the button down and sliding the red tube into opposing tube until the connection is made. To disassemble push button and pull or twist extrusions apart.

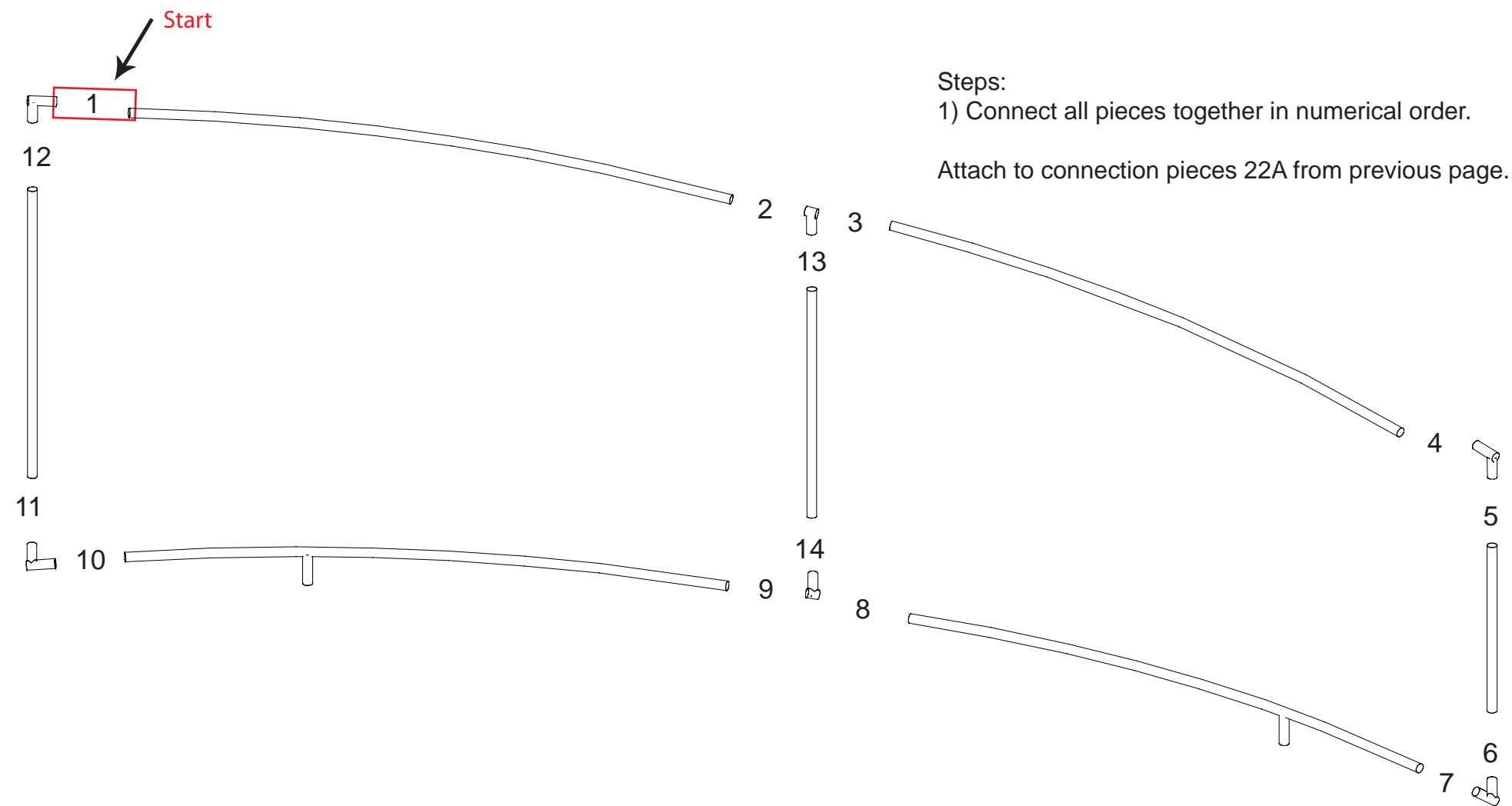
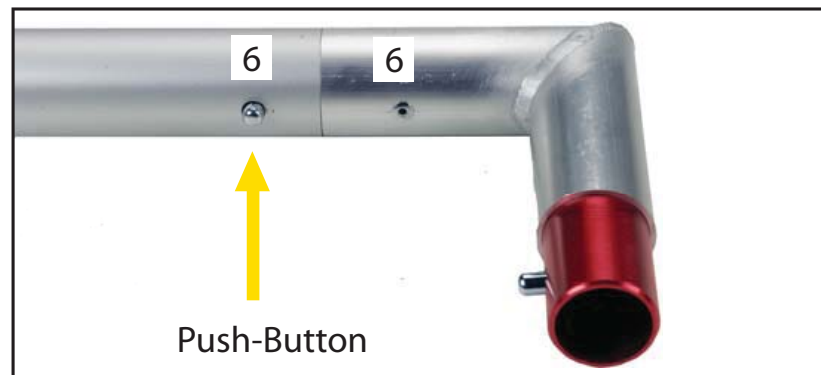

WHEN DISASSEMBLING ALUMINUM EXTRUSION, TIGHTEN ALL SETSCREWS AND LOCKS TO PREVENT LOSS DURING SHIPPING

866.652.2100

Part Number	Qty for Step	Description
11	1	96" Vertical extrusion
12	1	96" Vertical extrusion
13	2	42" 90° Vertical extrusion
14	2	15" Horizontal extrusion
15	1	72.9314" Curved Horizontal extrusion
16	1	72.9314" Curved Horizontal extrusion
17	1	60.8754" Curved Horizontal extrusion
18	1	60.8754" Curved Horizontal extrusion
19	2	38.418" Vertical extrusion
20	1	113.3618" Horizontal extrusion for Monitor Mount

Repeat Steps for Both Presentation Bars.

Steps

- 1) Attach horizontal curves [15 to 16 and 17 to 18].
- 2) Connect horizontal extrusions [14] between vertical extrusions [11, 12, and 13] as shown below.
- 3) Connect lower curved horizontal assemblies [15/16 and 17/18] between vertical extrusions [11, 12 and 13] as shown below.
- 4) Connect vertical extrusions [19] to center top of horizontal assemblies [15/16 and 17/18].
- 5) Place inserts where indicated.
- 6) Connect upper curved horizontal assemblies [15/16 and 17/18] between vertical extrusions [11, 12 and 13] and atop inserts.
- 7) Connect horizontal extrusions [14] between vertical extrusions [11, 12, and 13].

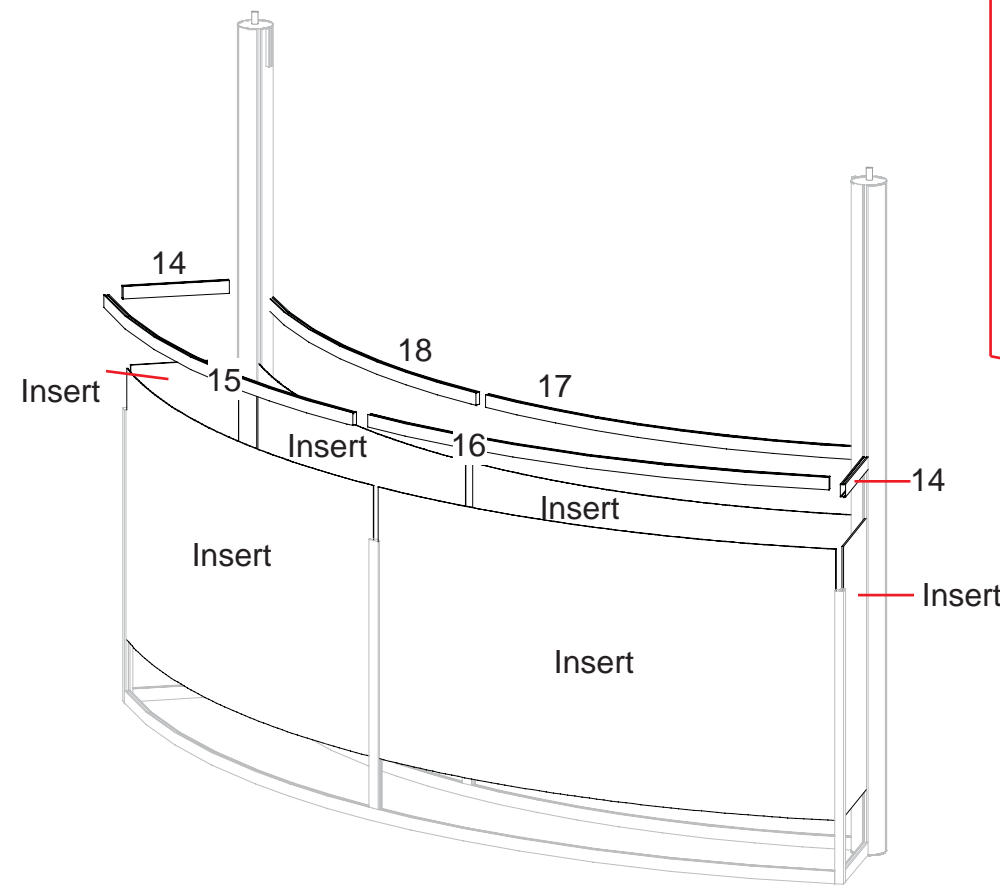
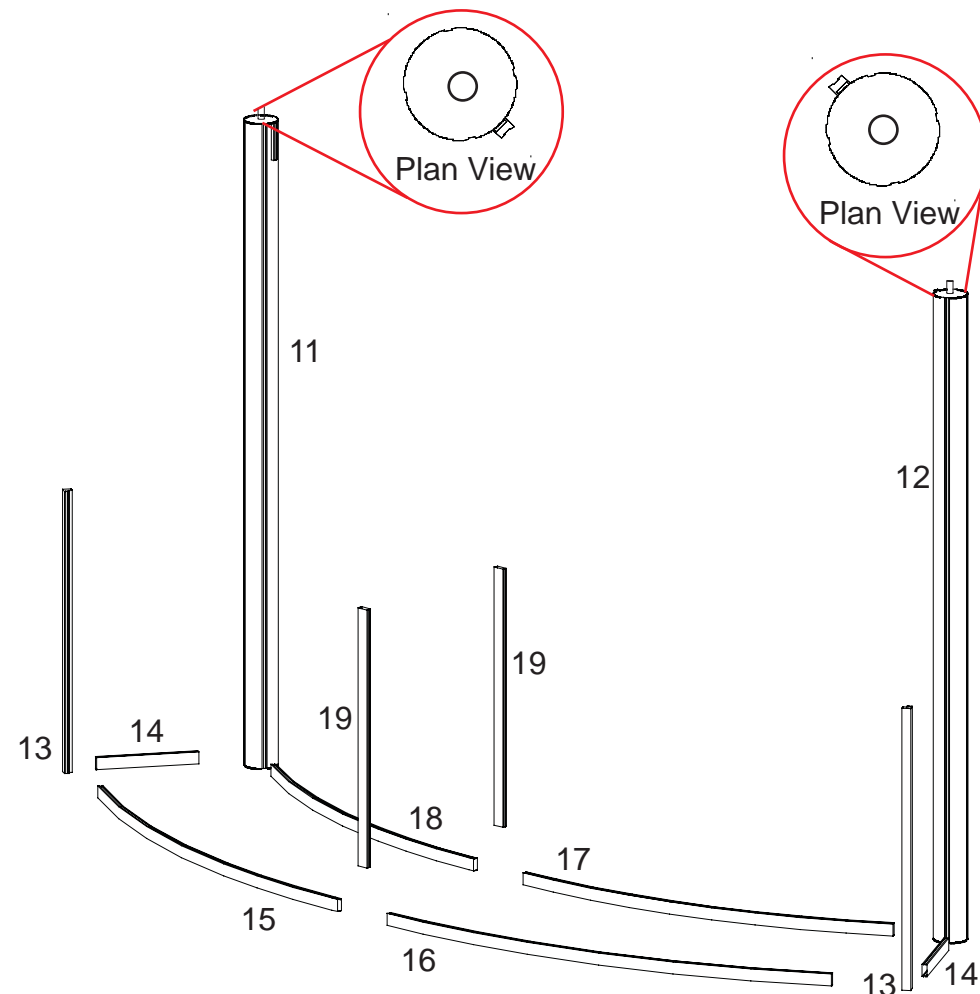
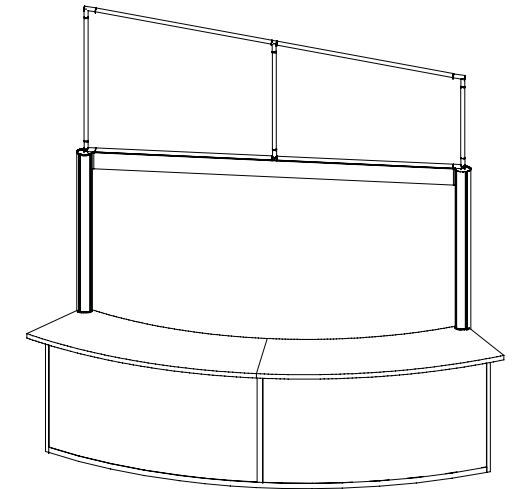
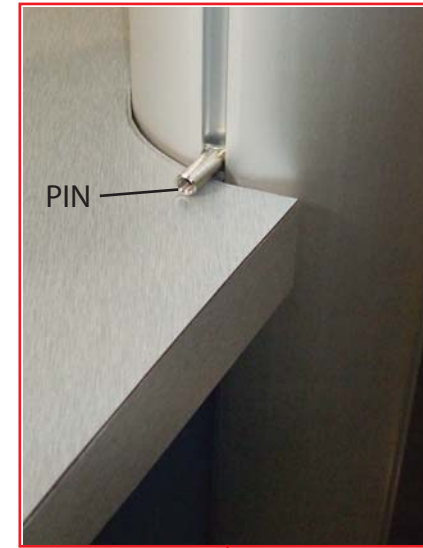

- 8) Attach horizontal extrusion [20] between vertical extrusions [11 and 12] making sure it sets flush with permanently attached connections.

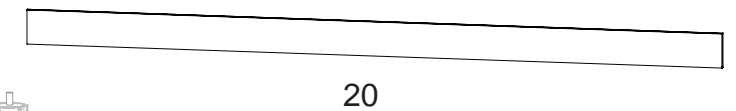

- 9) Assemble Counter top and Place atop assembled Base.
- 10) Insert PIN into groove of vertical and tighten with hex key to secure counter into place.

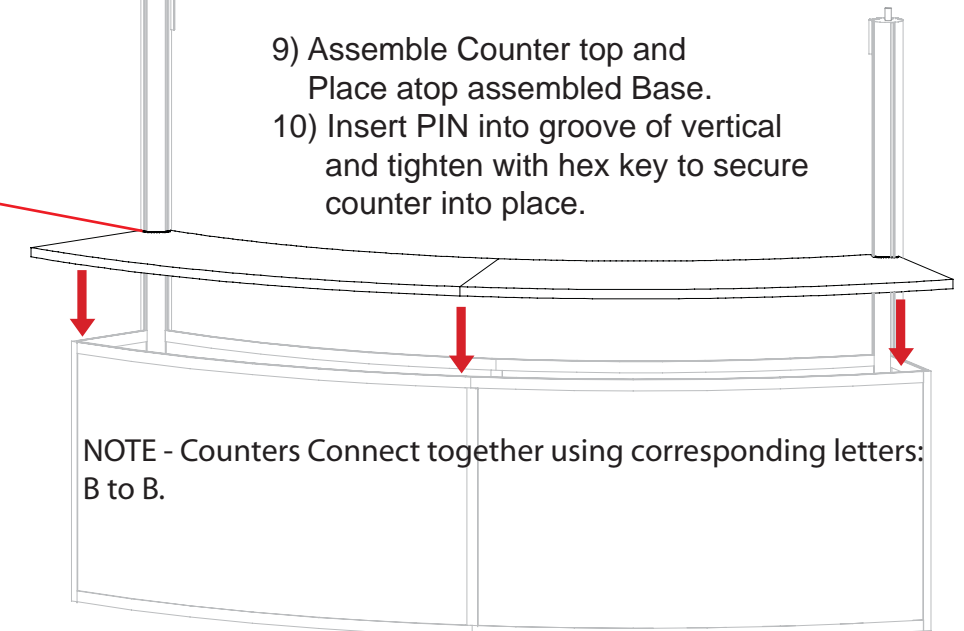

WHEN DISASSEMBLING ALUMINUM EXTRUSION, TIGHTEN ALL SETSCREWS AND LOCKS TO PREVENT LOSS DURING SHIPPING



866.652.2100

Using Your Setup Instructions

The Aero Overhead Sign Setup Instructions are created specifically for your configuration. They include an exploded view of the frame which is sequentially numbered. We encourage you to study the instructions before attempting to assemble your exhibit.

Connections are kept very simple: no tools. Everything assembles with push-button connectors and pre-connected horizontal sections.

Cleaning and Packing Your Display

- 1) Use care when cleaning aluminum extrusion or acrylic inserts. Use only non-abrasive cleaners.
- 2) Retain all packing material. It will make re-packing much easier and will reduce the likelihood of shipping damage.

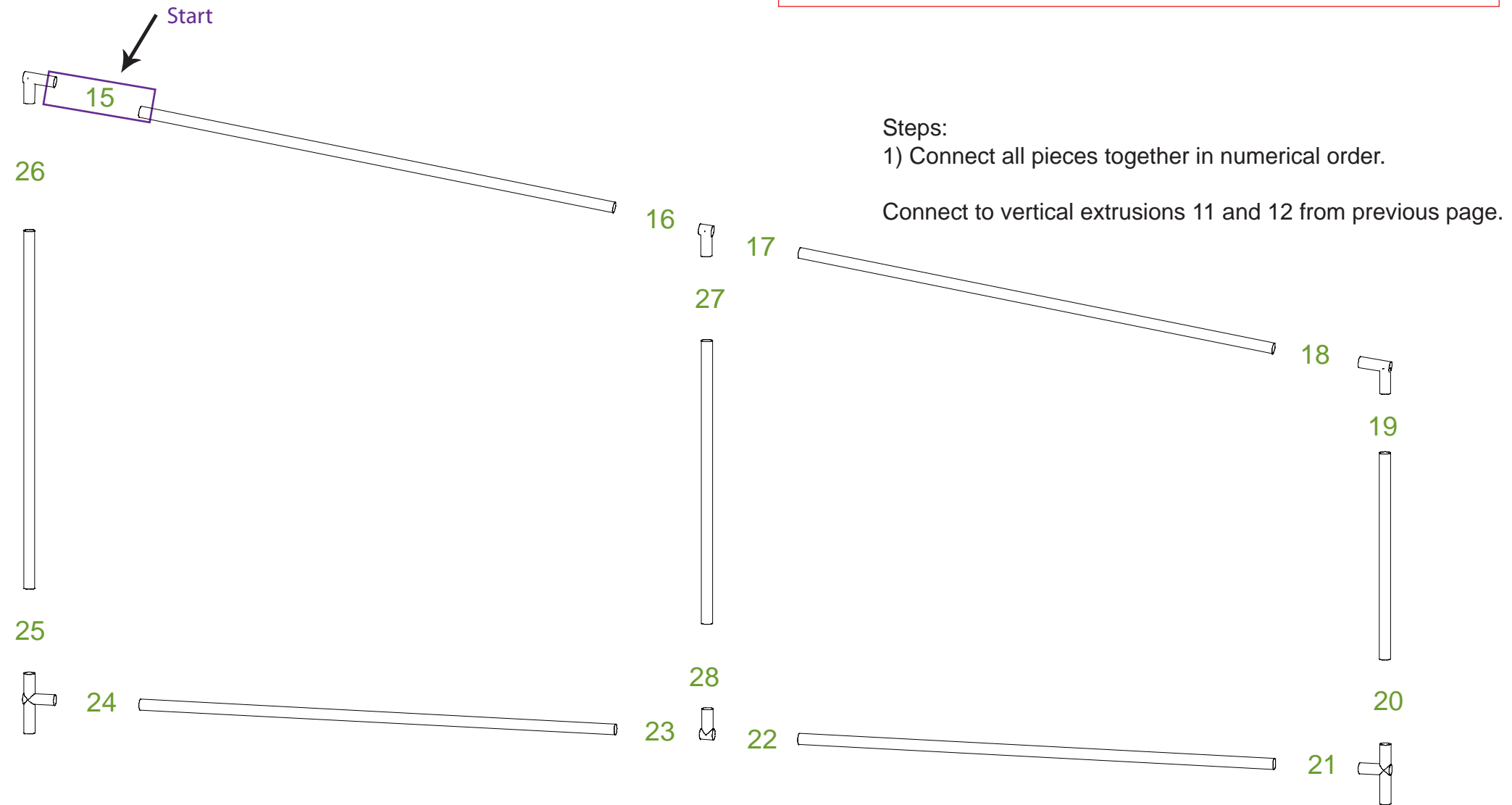
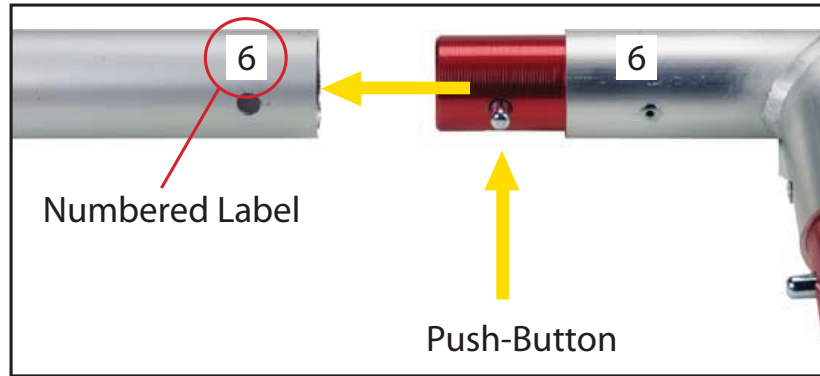
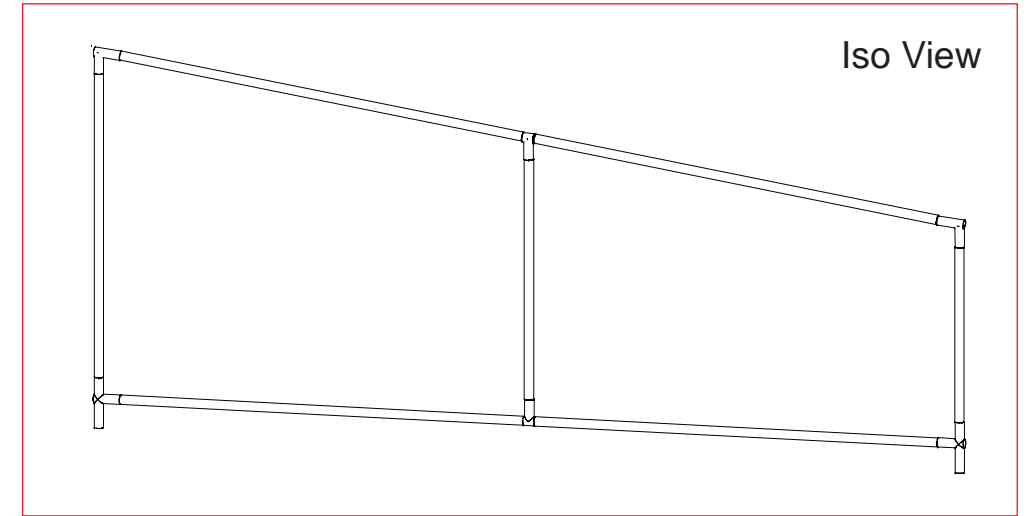

Steps:

- 1) Connect all pieces together in numerical order.

Connect to vertical extrusions 11 and 12 from previous page.

Connections are made by holding the button down and sliding the red tube into opposing tube until the connection is made. To disassemble push button and pull or twist extrusions apart.

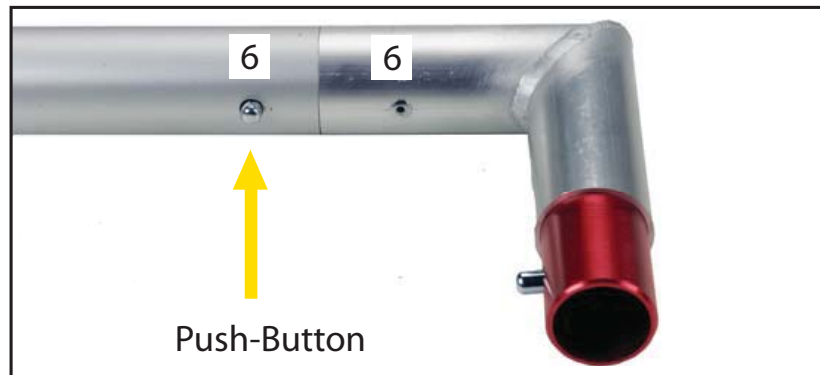

WHEN DISASSEMBLING ALUMINUM EXTRUSION, TIGHTEN ALL SETSCREWS AND LOCKS TO PREVENT LOSS DURING SHIPPING

866.652.2100



Using Your Setup Instructions

The Aero Overhead Sign Setup Instructions are created specifically for your configuration. They include an exploded view of the frame which is sequentially numbered. We encourage you to study the instructions before attempting to assemble your exhibit.

Connections are kept very simple: no tools. Everything assembles with push-button connectors and pre-connected horizontal sections.

Cleaning and Packing Your Display

- 1) Use care when cleaning aluminum extrusion or acrylic inserts. Use only non-abrasive cleaners.
- 2) Retain all packing material. It will make re-packing much easier and will reduce the likelihood of shipping damage.

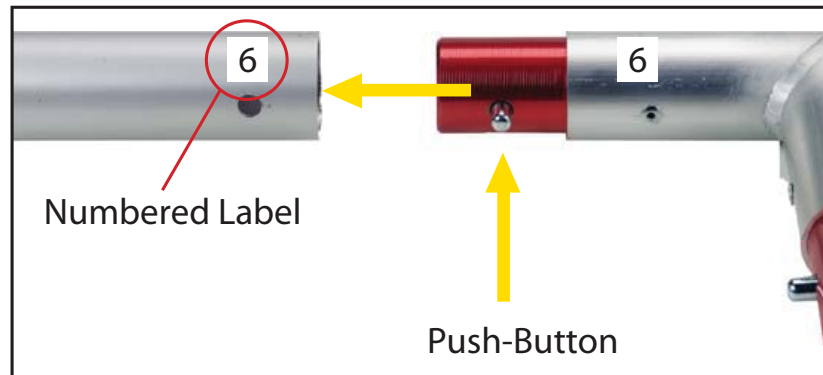
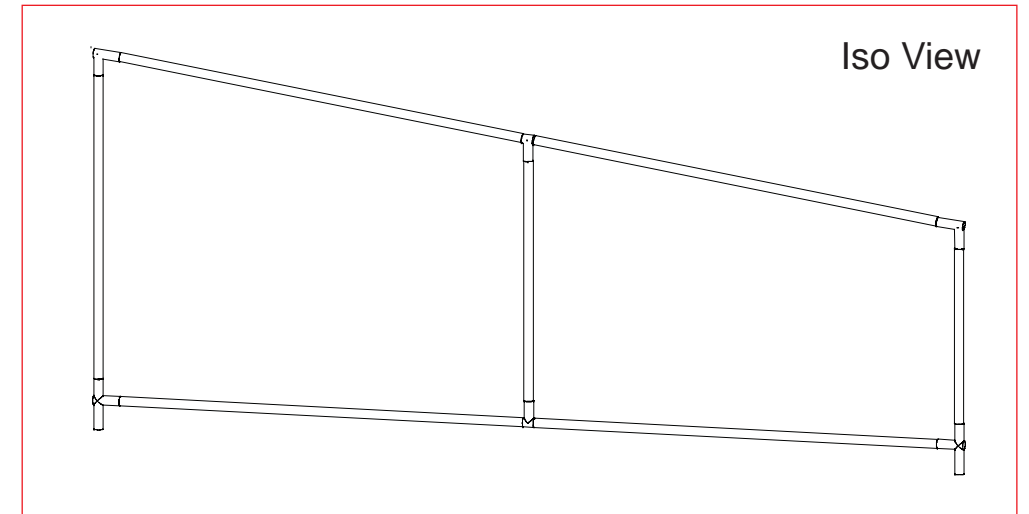

Connections are made by holding the button down and sliding the red tube into opposing tube until the connection is made. To disassemble push button and pull or twist extrusions apart.

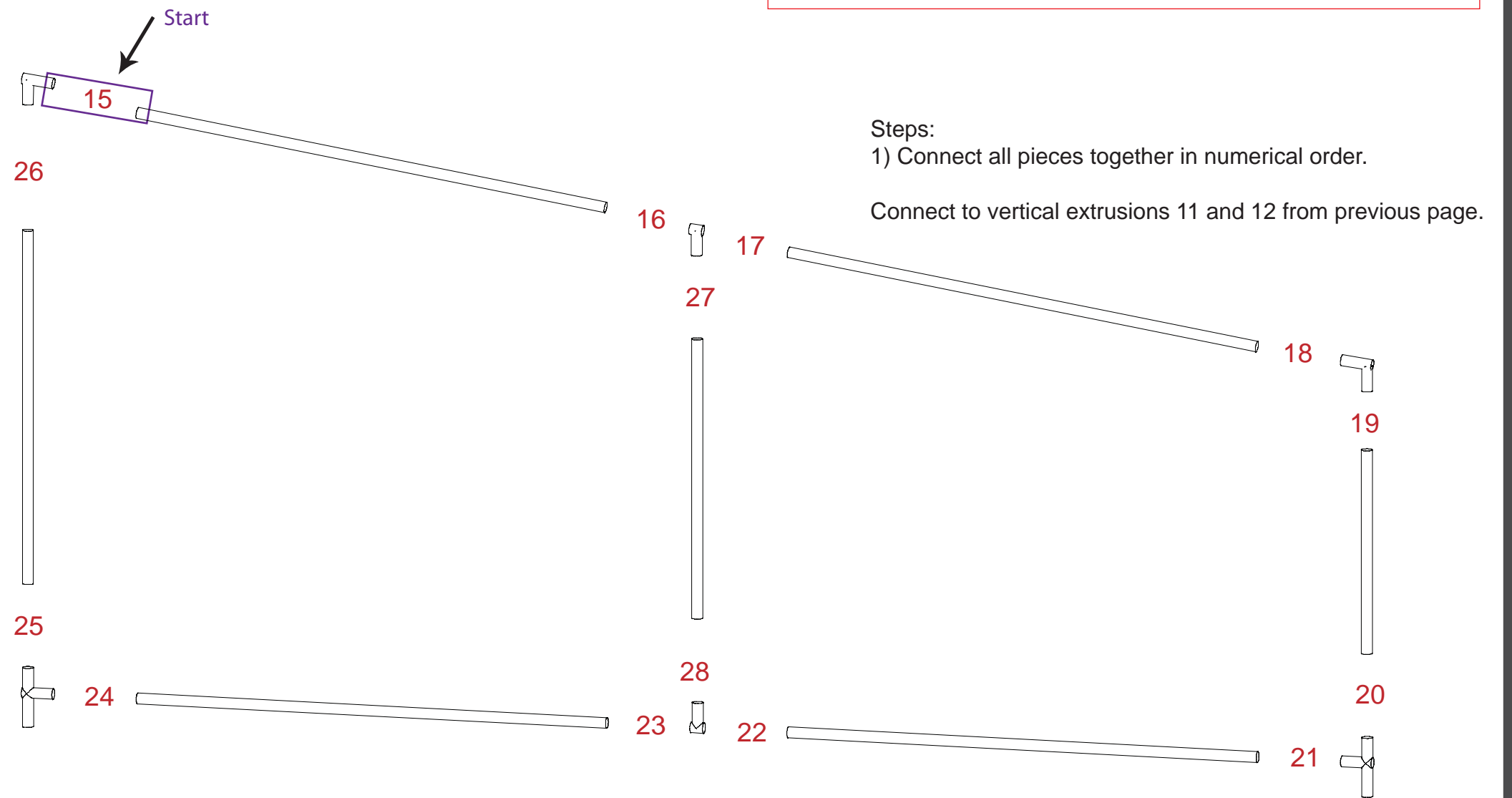
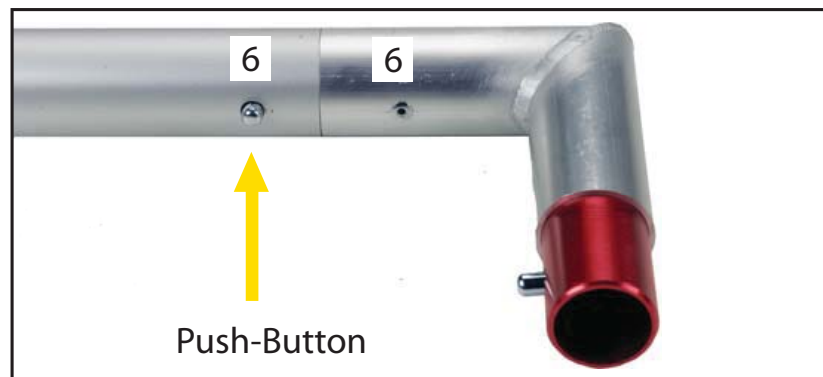

WHEN DISASSEMBLING ALUMINUM EXTRUSION, TIGHTEN ALL SETSCREWS AND LOCKS TO PREVENT LOSS DURING SHIPPING

866.652.2100

Part Number	Description
1	16"r x 42"h Curved Panel
2	42"h T- Connector
3	16"r x 42"h Curved Panel w/Door
4	42"h T- Connector
5	16"r x 42"h Curved Panel
6	42"h T- Connector
7	16"r x 42"h Curved Panel
8	42"h T- Connector
9	42"h Tapered Counter Support
10	42"h Tapered Counter Support
11	42"h Tapered Counter Support
12	42"h Tapered Counter Support

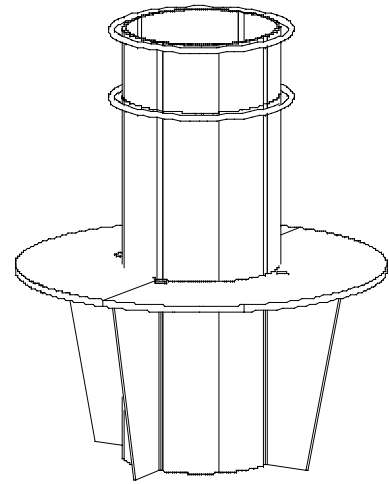

Part Number	Description
1	16"r x 38"h Curved Panel
2	38"h 180° Connector
3	16"r x 38"h Curved Panel
4	38"h 180° Connector
5	16"r x 38"h Curved Panel
6	38"h 180° Connector
7	16"r x 38"h Curved Panel
8	38"h 180° Connector

Part Number	Description
1	16"r x 15"h Curved Panel
2	15"h 180° Connector
3	16"r x 15"h Curved Panel
4	15"h 180° Connector
5	16"r x 15"h Curved Panel
6	15"h 180° Connector
7	16"r x 15"h Curved Panel
8	15"h 180° Connector

Level 1

Steps
1) Assemble panels in numerical order starting with #1.

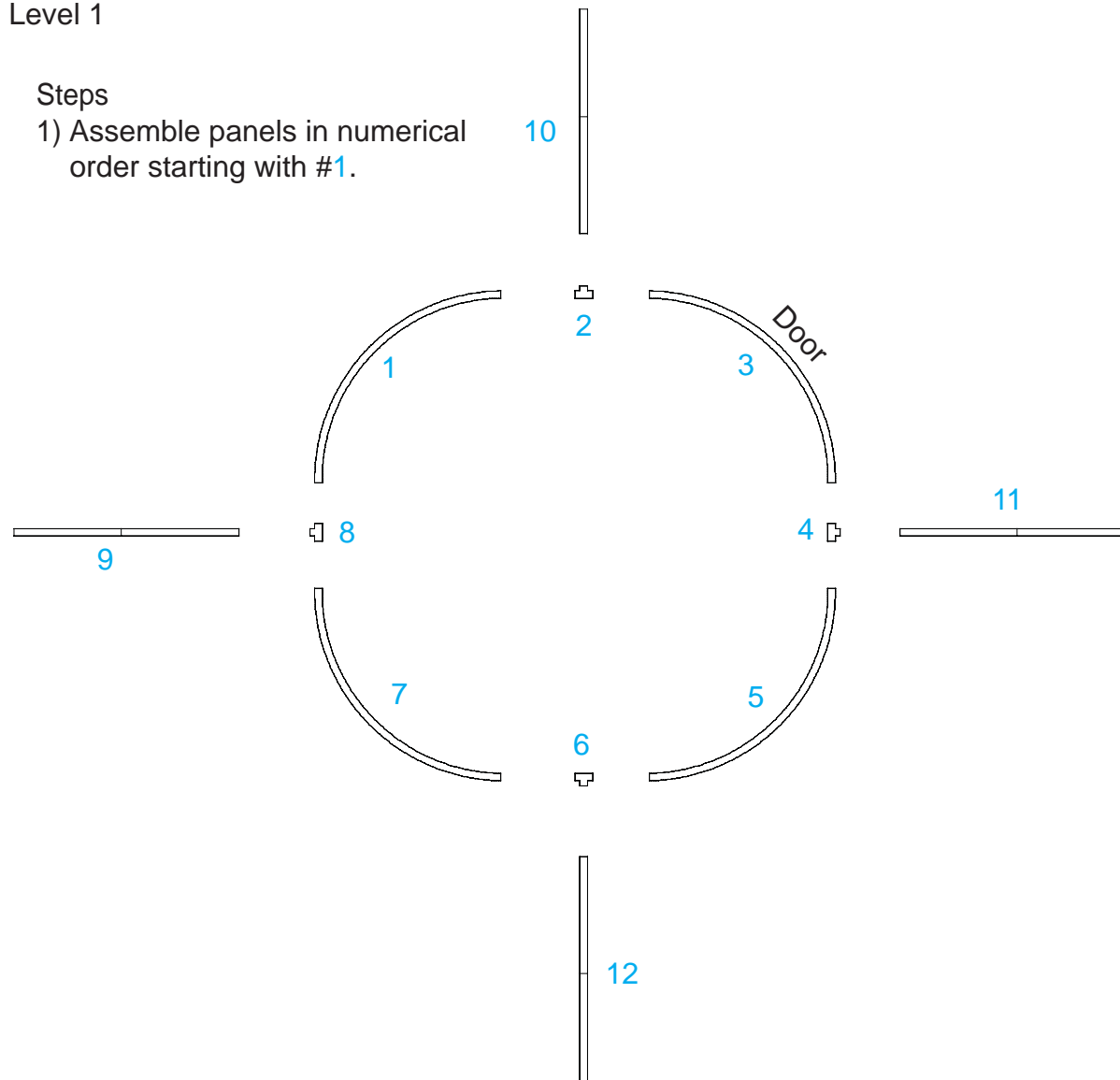

Level 2

Steps
1) Assemble panels in numerical order starting with #1.

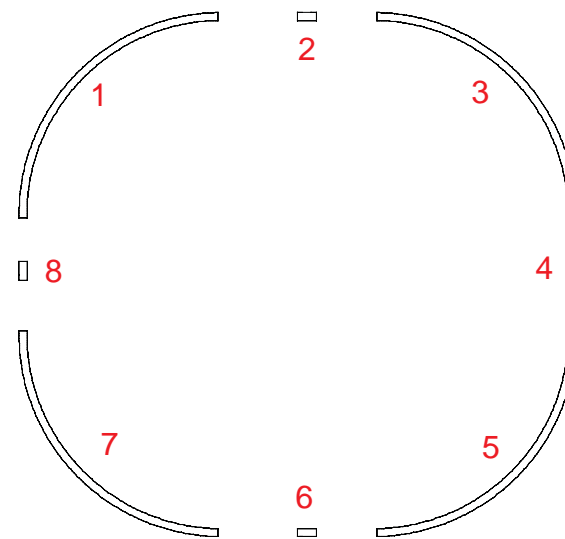

Level 3

Steps
1) Assemble panels in numerical order starting with #1.

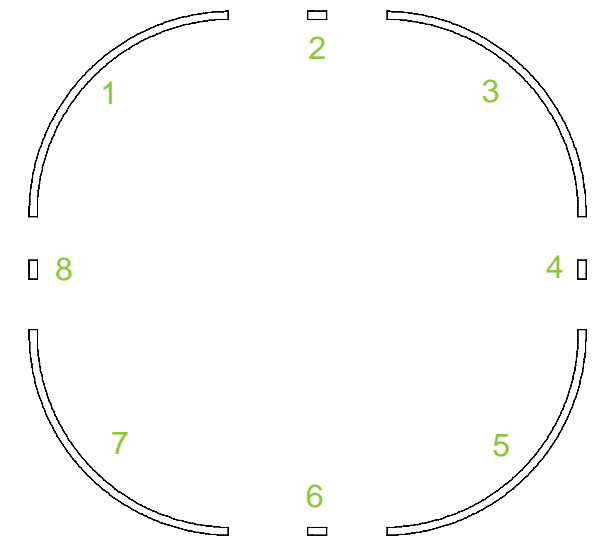

WHEN DISASSEMBLING ALUMINUM EXTRUSION, TIGHTEN ALL SETSCREWS AND LOCKS TO PREVENT LOSS DURING SHIPPING

866.652.2100

Part Number	Description
15	16"r x 42"h Curved Panel w/Door
16	42"h T- Connector
17	16"r x 42"h Curved Panel
18	42"h T- Connector
19	16"r x 42"h Curved Panel
20	42"h T- Connector
21	16"r x 42"h Curved Panel
22	42"h T- Connector
23	42"h Tapered Counter Support
24	42"h Tapered Counter Support
25	42"h Tapered Counter Support
26	42"h Tapered Counter Support

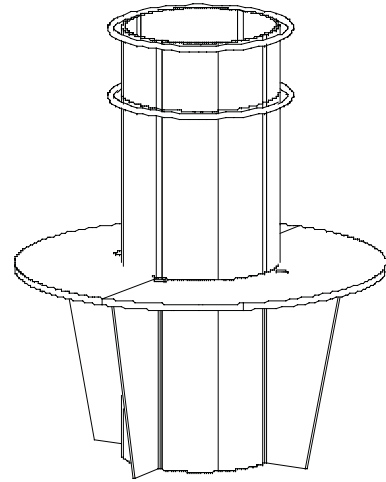

Part Number	Description
15	16"r x 38"h Curved Panel
16	38"h 180° Connector
17	16"r x 38"h Curved Panel
18	38"h 180° Connector
19	16"r x 38"h Curved Panel
20	38"h 180° Connector
21	16"r x 38"h Curved Panel
22	38"h 180° Connector

Part Number	Description
15	16"r x 15"h Curved Panel
16	15"h 180° Connector
17	16"r x 15"h Curved Panel
18	15"h 180° Connector
19	16"r x 15"h Curved Panel
20	15"h 180° Connector
21	16"r x 15"h Curved Panel
22	15"h 180° Connector

Level 1

Steps
1) Assemble panels in numerical order starting with #15.

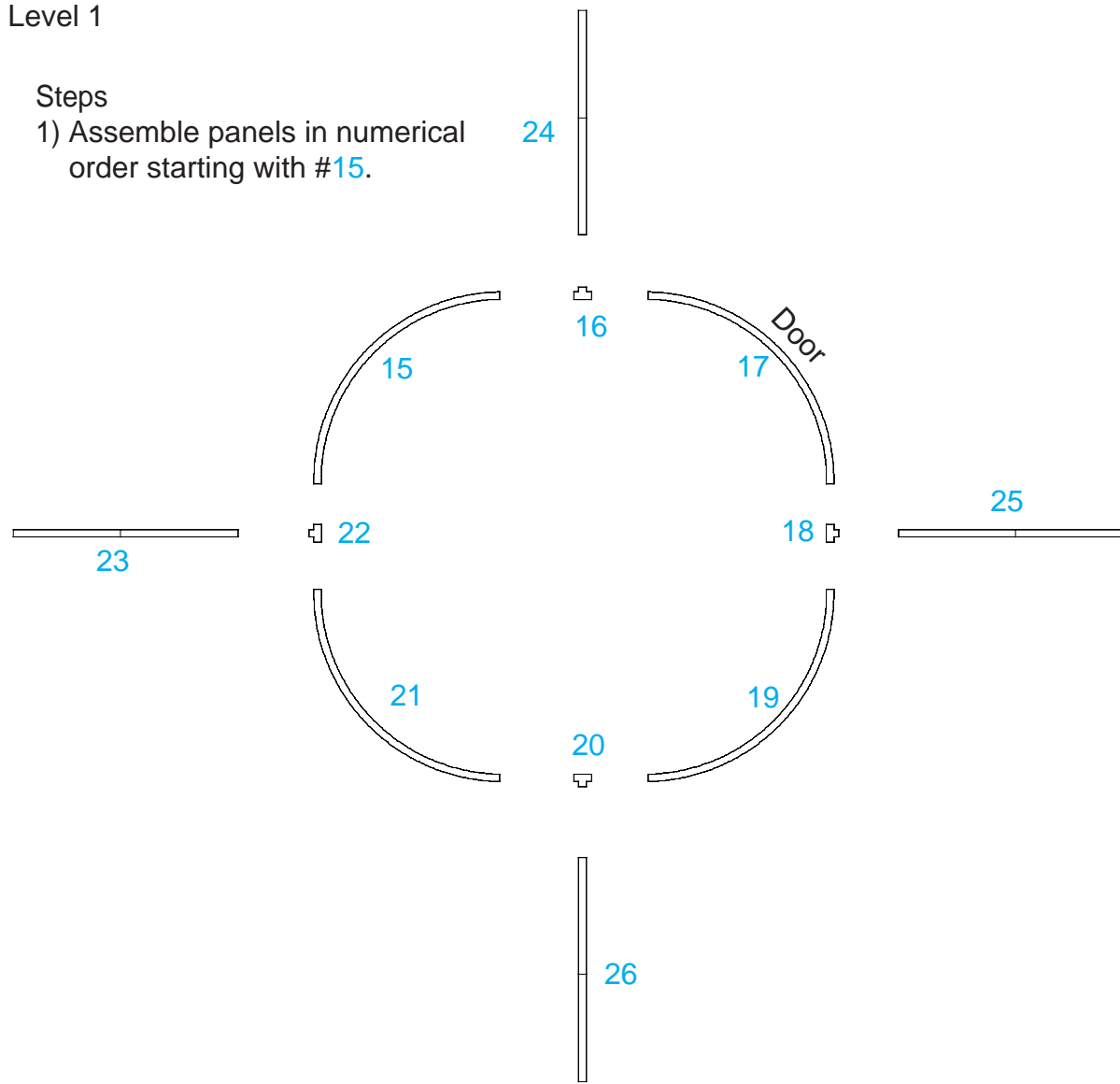

Level 2

Steps
1) Assemble panels in numerical order starting with #15.

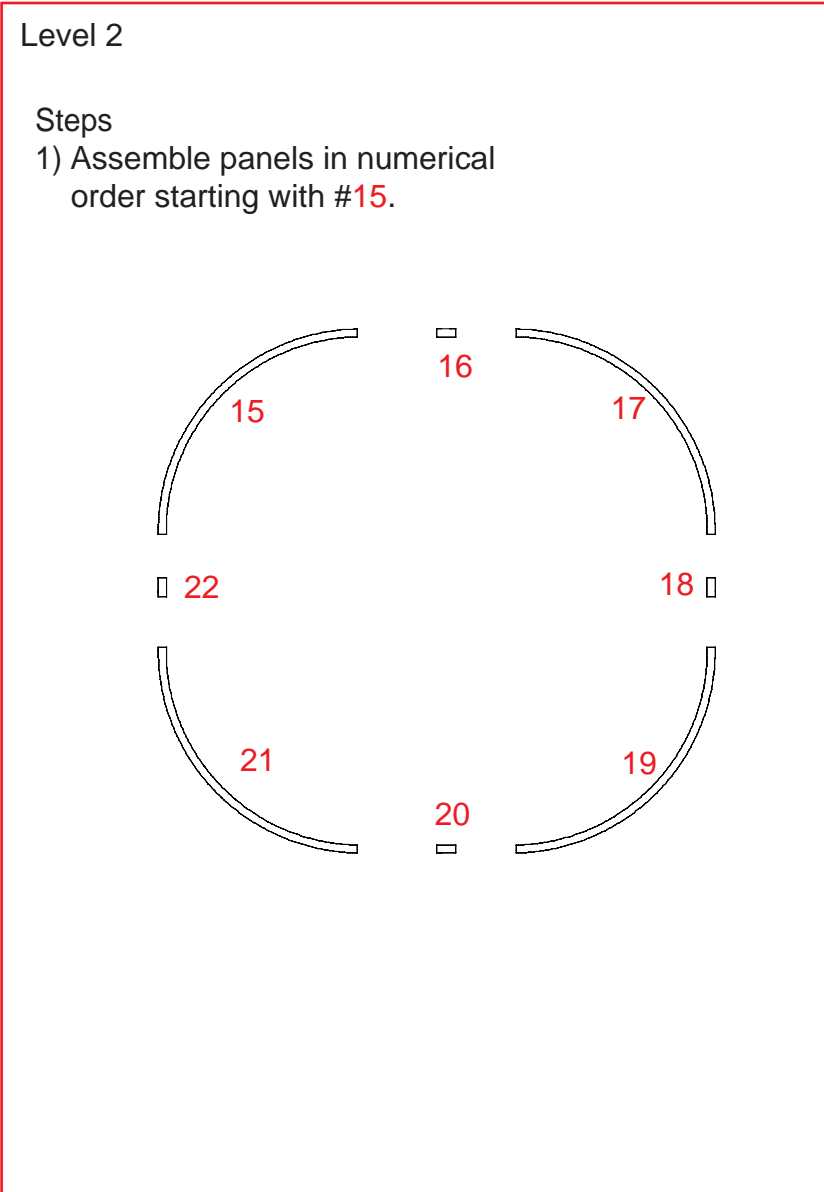

Level 3

Steps
1) Assemble panels in numerical order starting with #15.

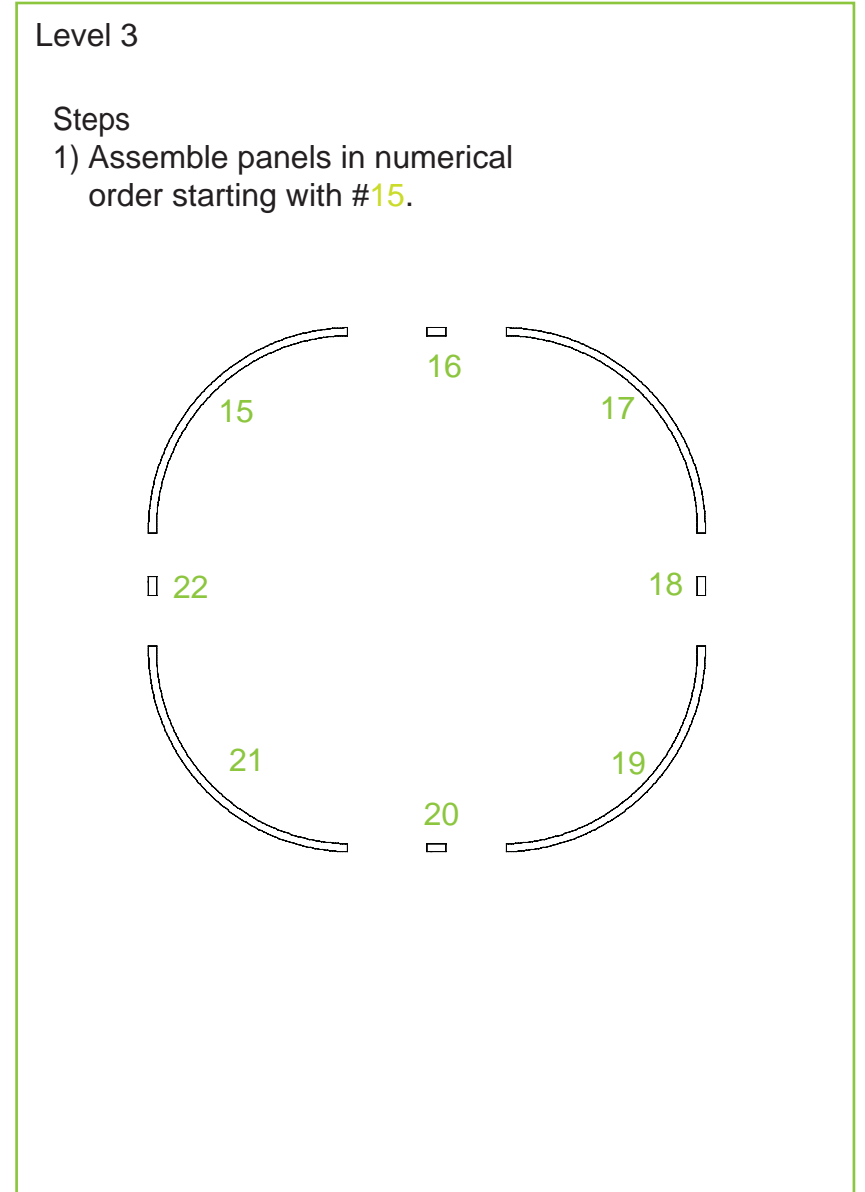

WHEN DISASSEMBLING ALUMINUM EXTRUSION, TIGHTEN ALL SETSCREWS AND LOCKS TO PREVENT LOSS DURING SHIPPING



Using Your Setup Instructions

The Aero Overhead Sign Setup Instructions are created specifically for your configuration. They include an exploded view of the frame which is sequentially numbered. We encourage you to study the instructions before attempting to assemble your exhibit.

Connections are kept very simple: no tools. Everything assembles with push-button connectors and pre-connected horizontal sections.

Cleaning and Packing Your Display

- 1) Use care when cleaning aluminum extrusion or acrylic inserts. Use only non-abrasive cleaners.
- 2) Retain all packing material. It will make re-packing much easier and will reduce the likelihood of shipping damage.

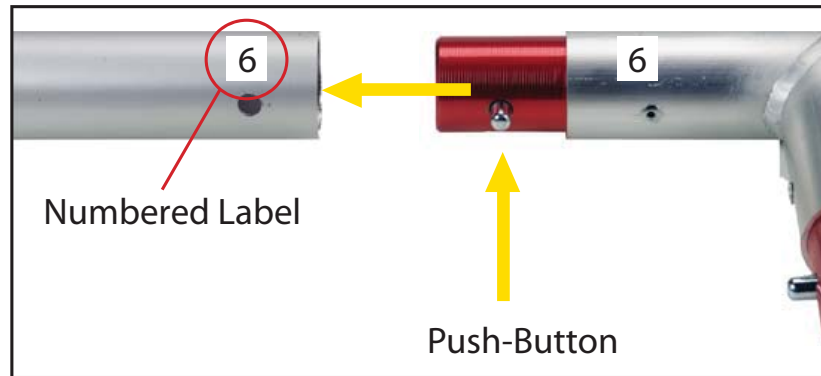

Connections are made by holding the button down and sliding the red tube into opposing tube until the connection is made. To disassemble push button and pull or twist extrusions apart.

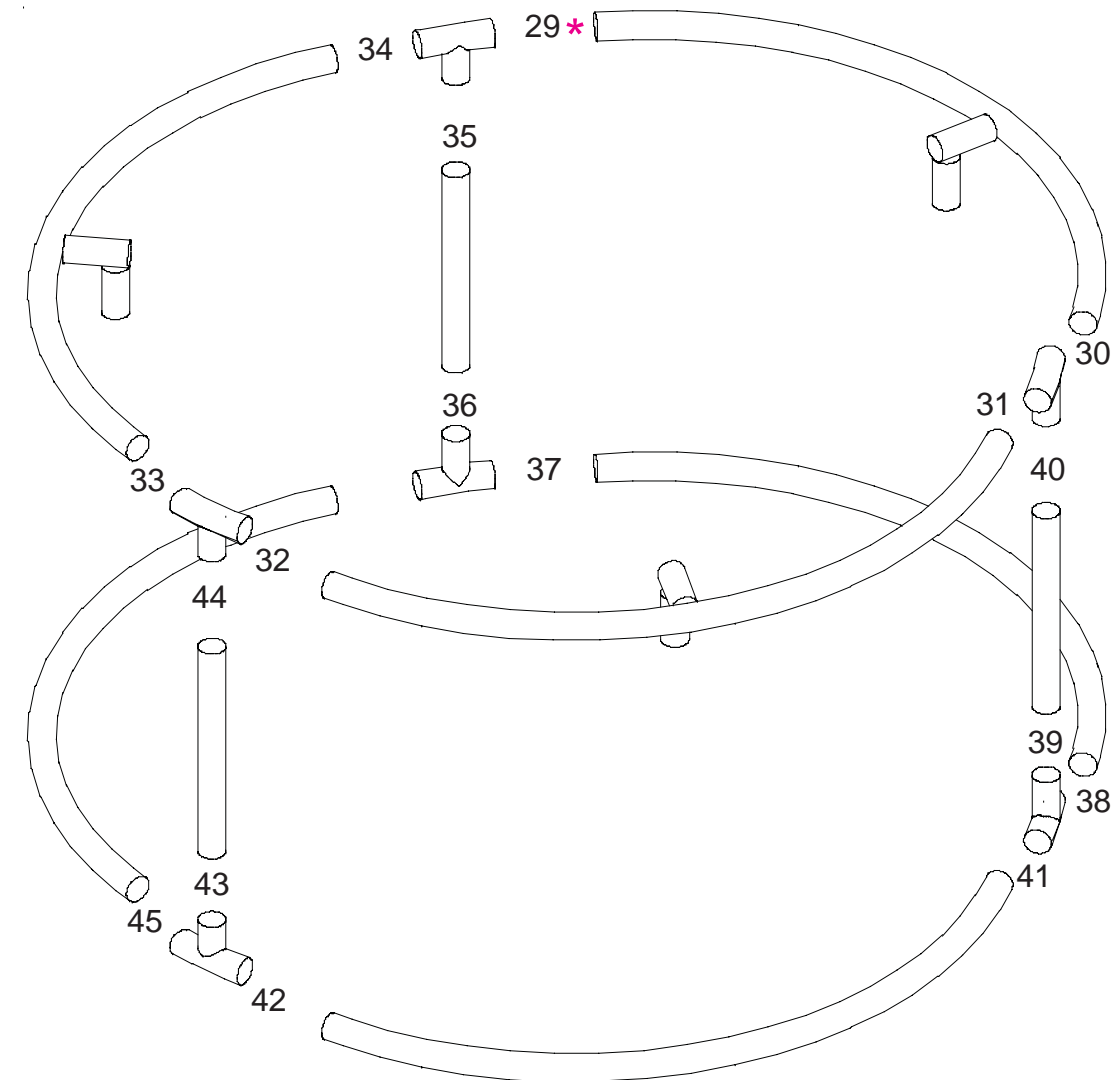

Assemble Frame in numerical order starting with #29 *
Repeat for BOTH Round Tower Aero Frames.

WHEN DISASSEMBLING ALUMINUM EXTRUSION, TIGHTEN ALL SETSCREWS AND LOCKS TO PREVENT LOSS DURING SHIPPING

866.652.2100

Repeat for Both Towers.

Place counter atop Supports and secure together.

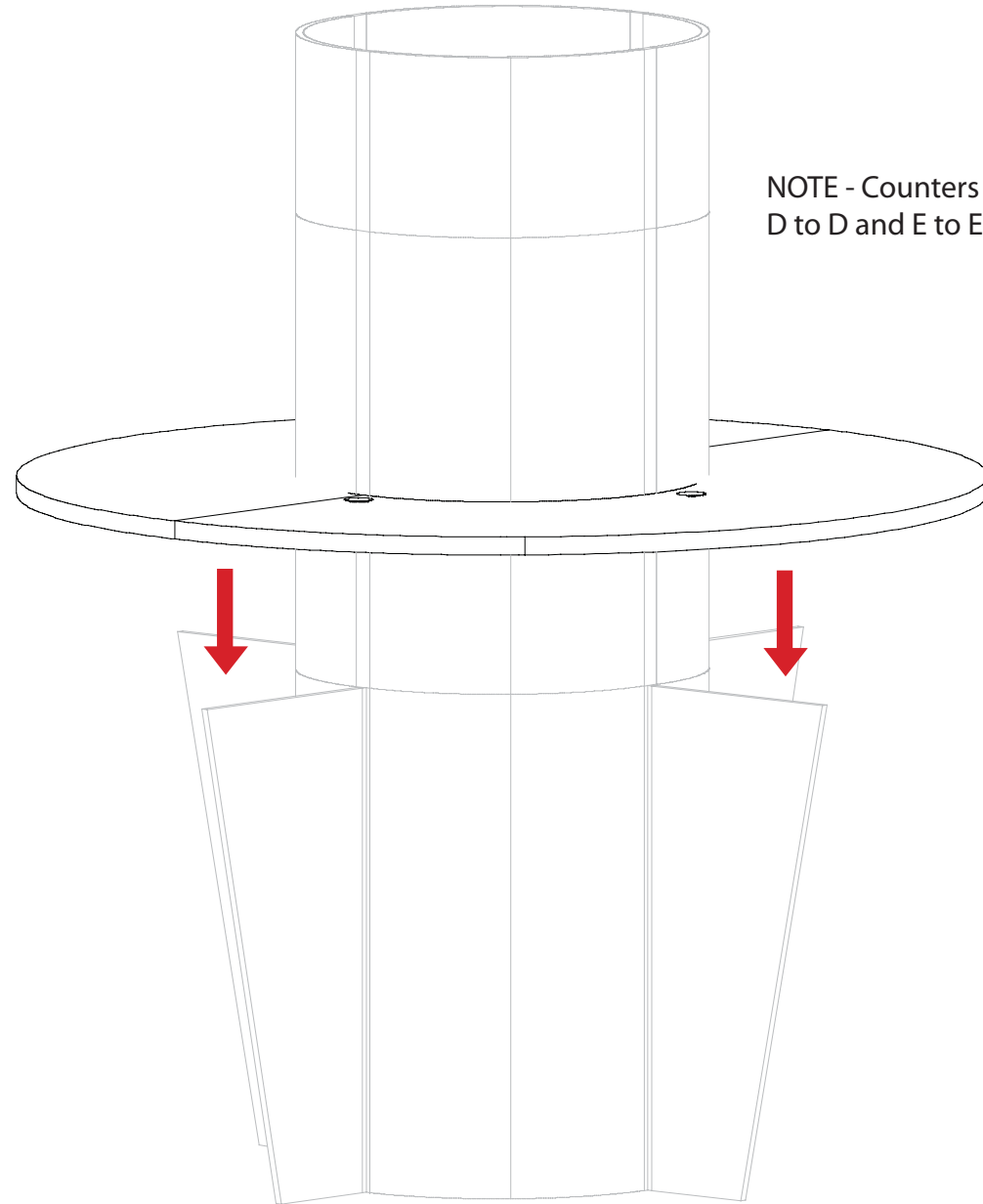

NOTE - Counters Connect together using corresponding letters: D to D and E to E.

After assembly of Aero Frame, apply graphics and set into place atop Tower.

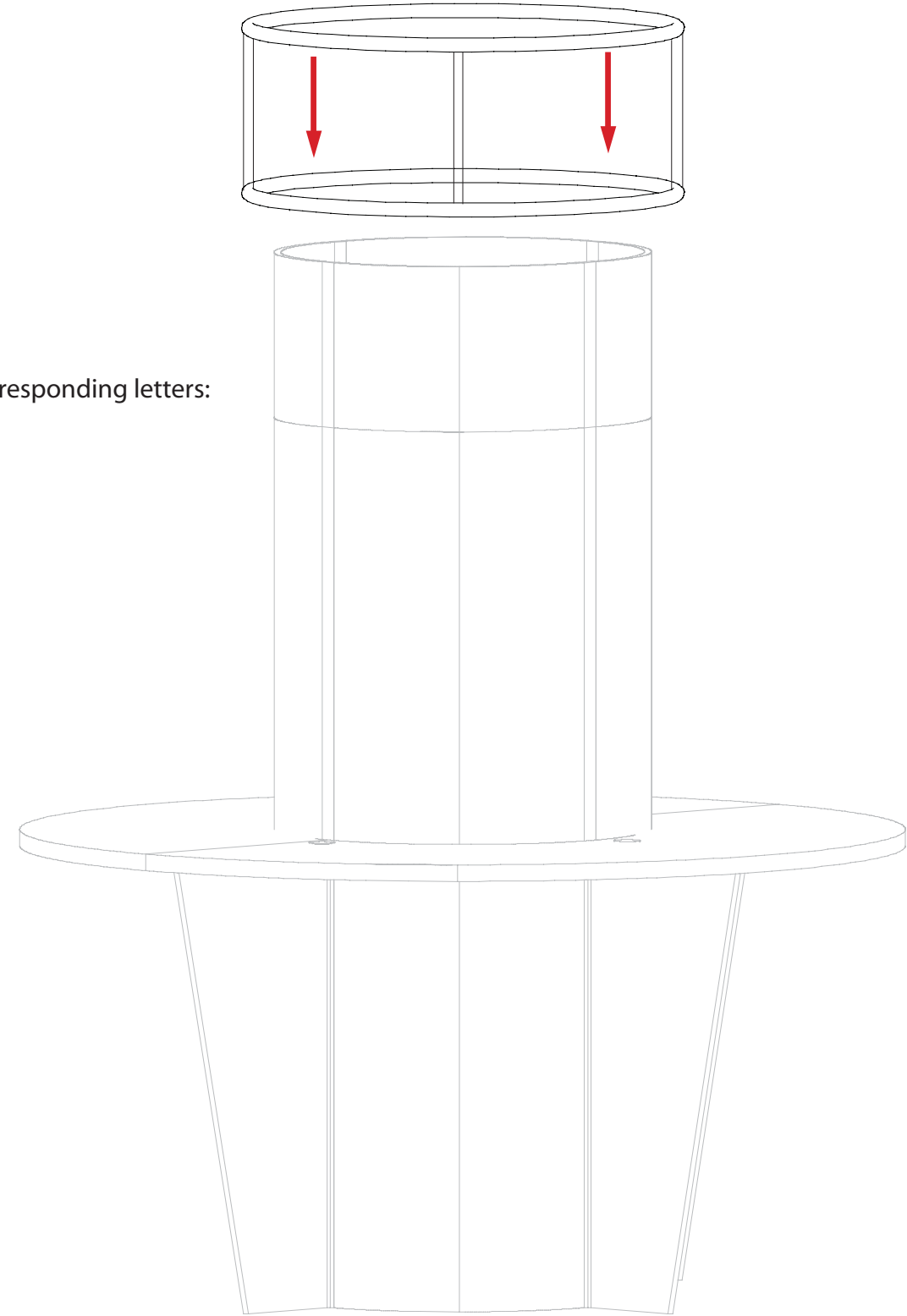

WHEN DISASSEMBLING ALUMINUM EXTRUSION, TIGHTEN ALL SETSCREWS AND LOCKS TO PREVENT LOSS DURING SHIPPING

Parts List - See next page for Assembly

866.652.2100

Part Number	Qty for Step	Description
26	2	42"h Vertical 90° extrusion
27	1	Curved Horizontal extrusion
28	1	Curved Horizontal extrusion
29/29A	1/1	7.115" Horizontal extrusion
30	2	12.209"h Vertical 90°extrusion
31	1	10.408"h Vertical extrusion
32	2	15.5"h Vertical 90°extrusion
33/33A	1/1	10.116" Horizontal extrusion w/ connection groove
34	1	Curved Horizontal Assembly
35	1	13.698"h Vertical extrusion
36	2	20" Vertical 90° extrusion
37/37A	1/1	13.115" Horizontal extrusion w/ connection groove
38	1	Curved Horizontal Assembly
39	1	16.418"h Vertical extrusion
40/40A	1/1	13.115" Horizontal extrusion
41	1	Curved Horizontal extrusion
42	1	Curved Horizontal extrusion

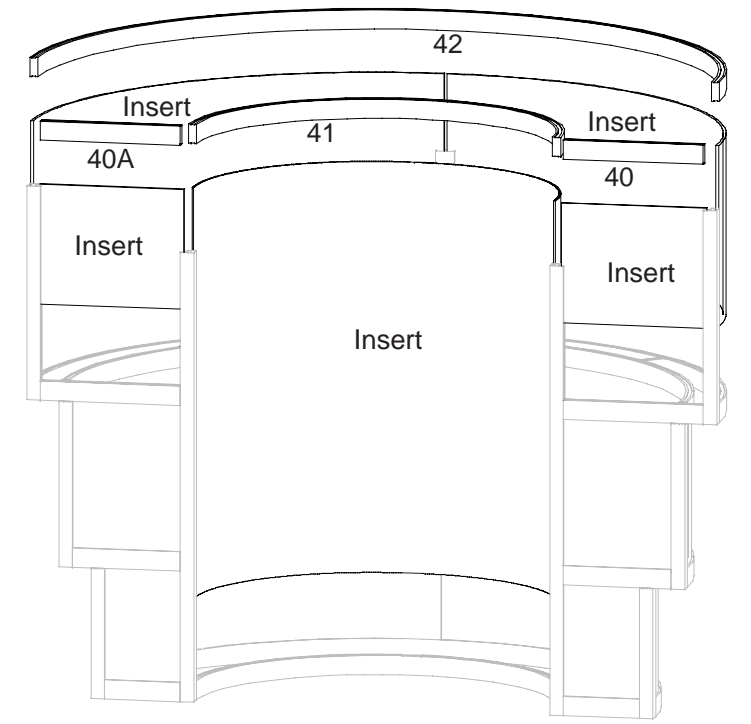
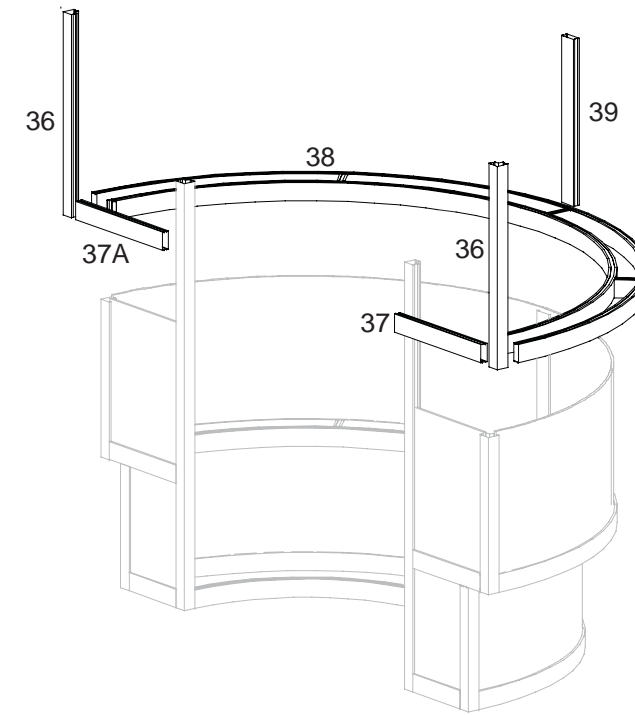
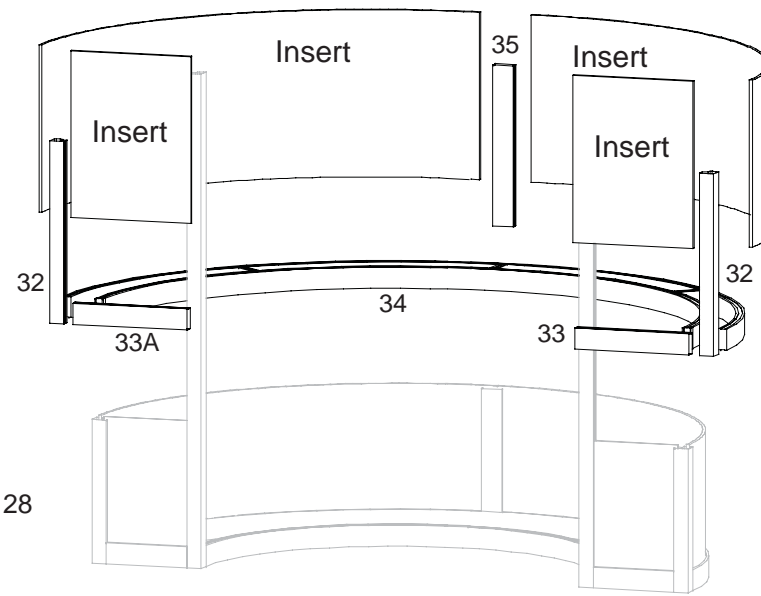
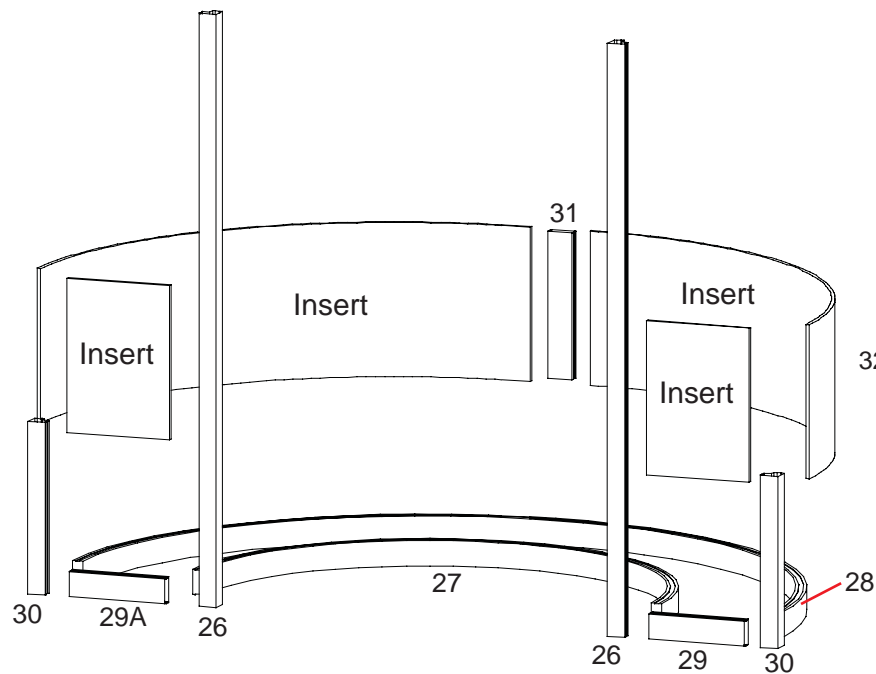
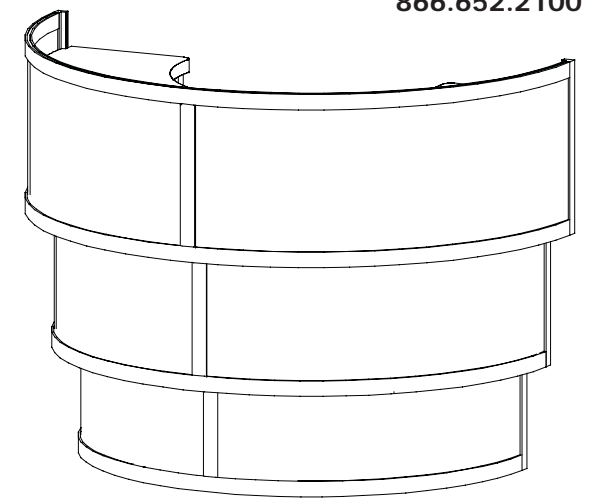

WHEN DISASSEMBLING ALUMINUM EXTRUSION, TIGHTEN ALL SETSCREWS AND LOCKS TO PREVENT LOSS DURING SHIPPING

866.652.2100

Steps: NOTE - Refer to previous page for parts list.

- 1) Connect curved horizontals [27 and 28] and [29 and 29A] between vertical extrusions [26 and 30].
- 2) Connect vertical extrusions [31] to center of curved horizontal [28], place inserts as indicated.

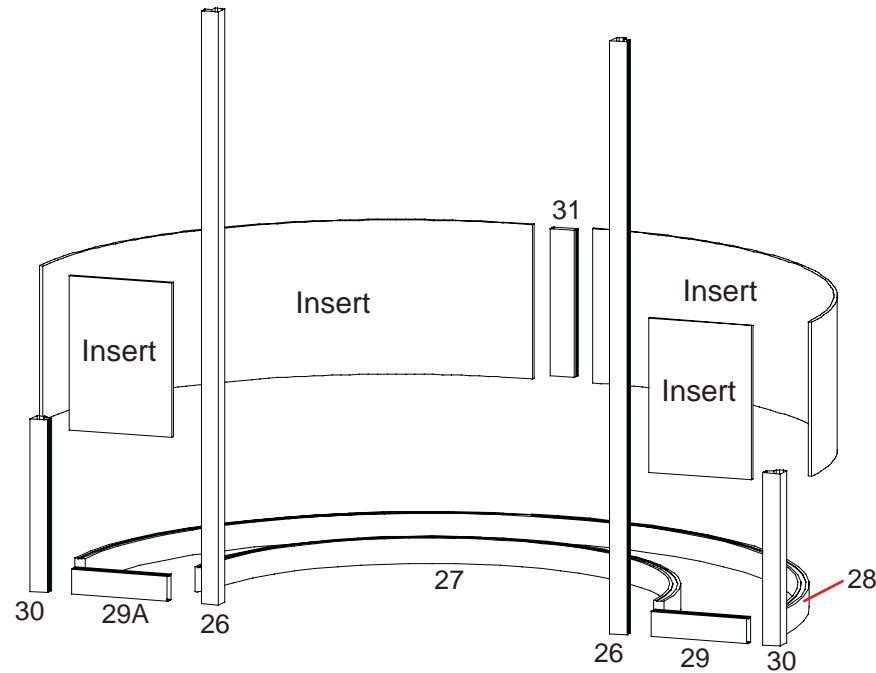

- 5) Connect curved horizontals [38] and [37 and 37A] between vertical extrusions [26 and 36]. Refer to connection detail at right.
- NOTE - Curved extrusions [38] should stay assembled for shipping and setup.

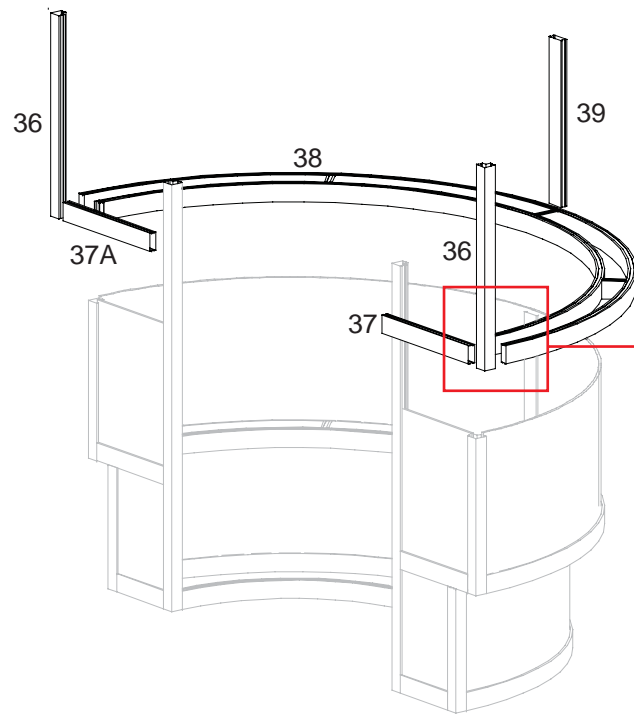

- 3) Connect curved horizontals [34] and [33 and 33A] between vertical extrusions [26 and 32]. Refer to connection detail at right.
 - 4) Place inserts as indicated.
- NOTE - Curved extrusions [34] should stay assembled for shipping and setup.

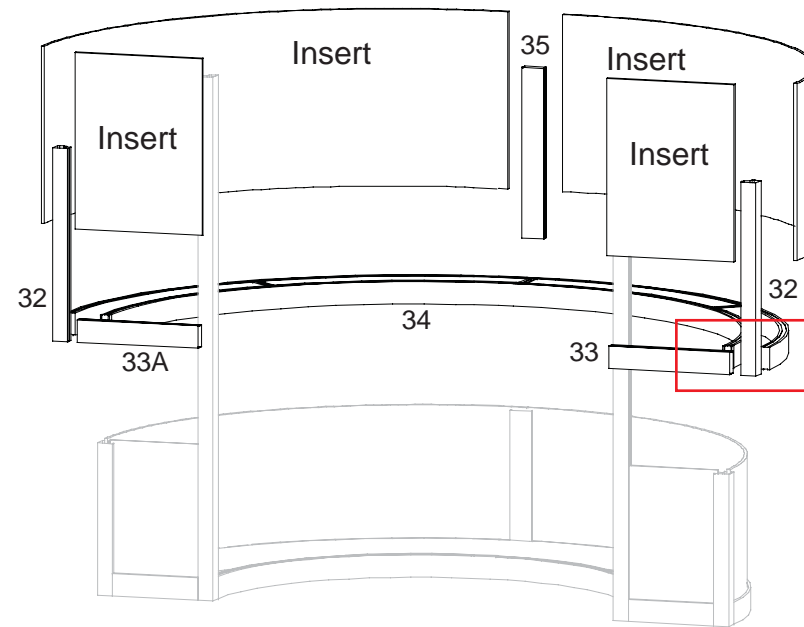

Connection detail

Extrusion 34 connects into vertical extrusion 32 and horizontal extrusion 33 as shown.

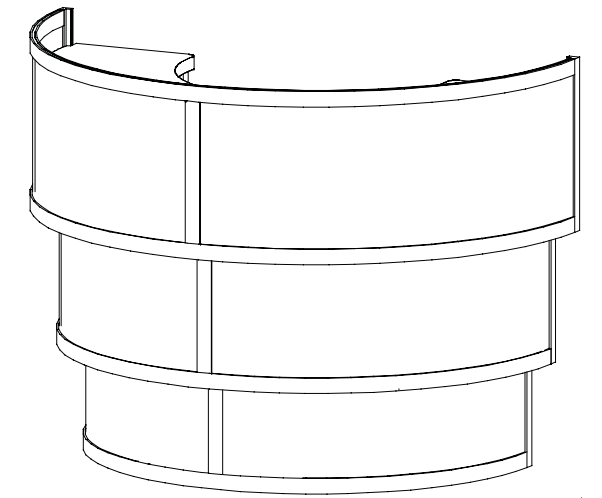
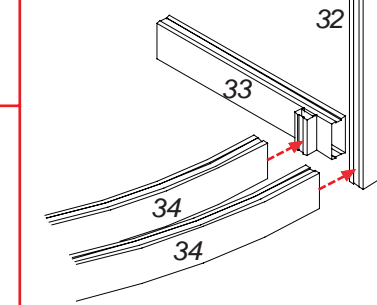

- 6) Place inserts as indicated.
- 7) Connect curved horizontals [41 and 42] and [40 and 40A] between vertical extrusions [26 and 36].

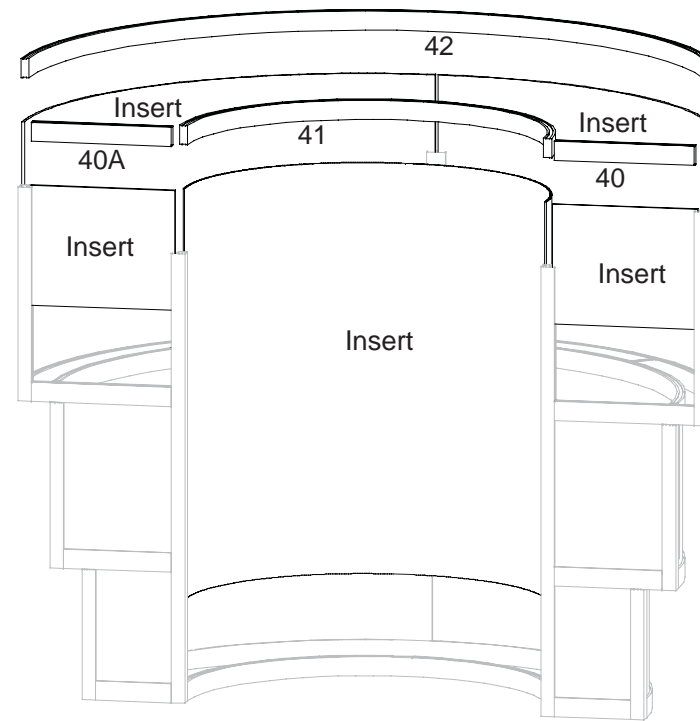

- 8) Set Counter into place atop pins.

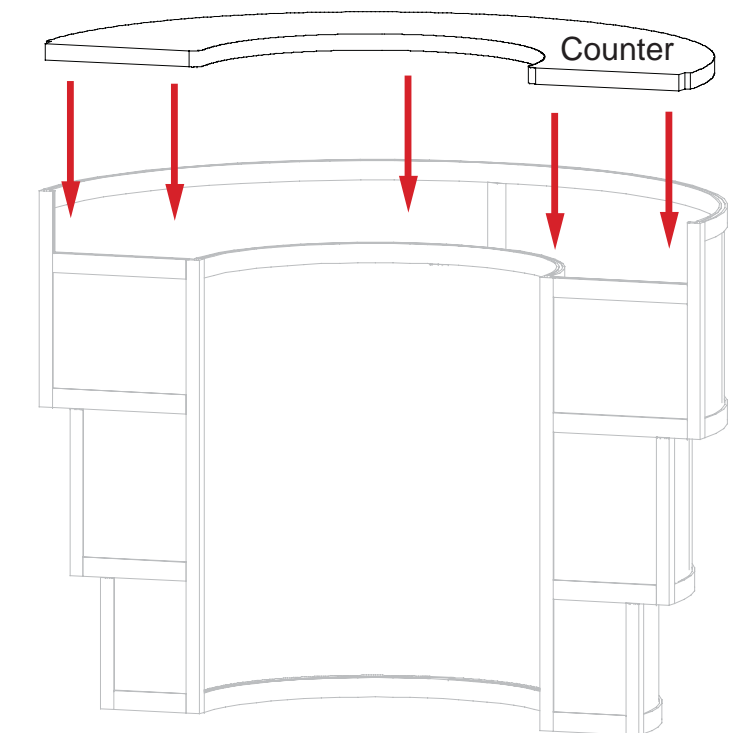

WHEN DISASSEMBLING ALUMINUM EXTRUSION, TIGHTEN ALL SETSCREWS AND LOCKS TO PREVENT LOSS DURING SHIPPING