

# euro It

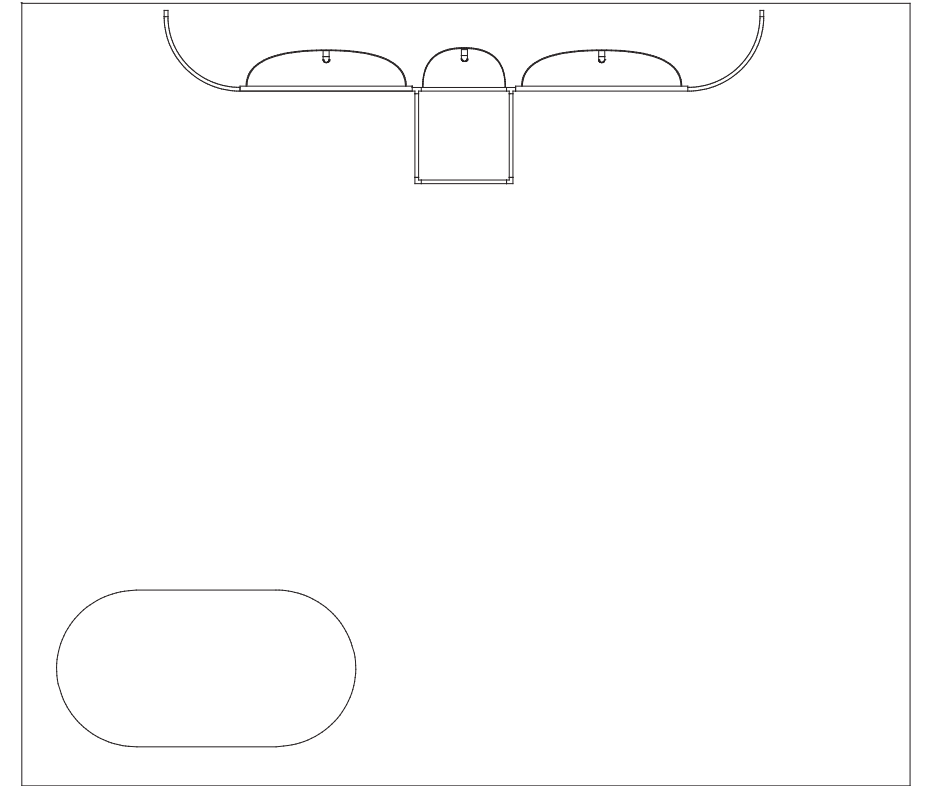
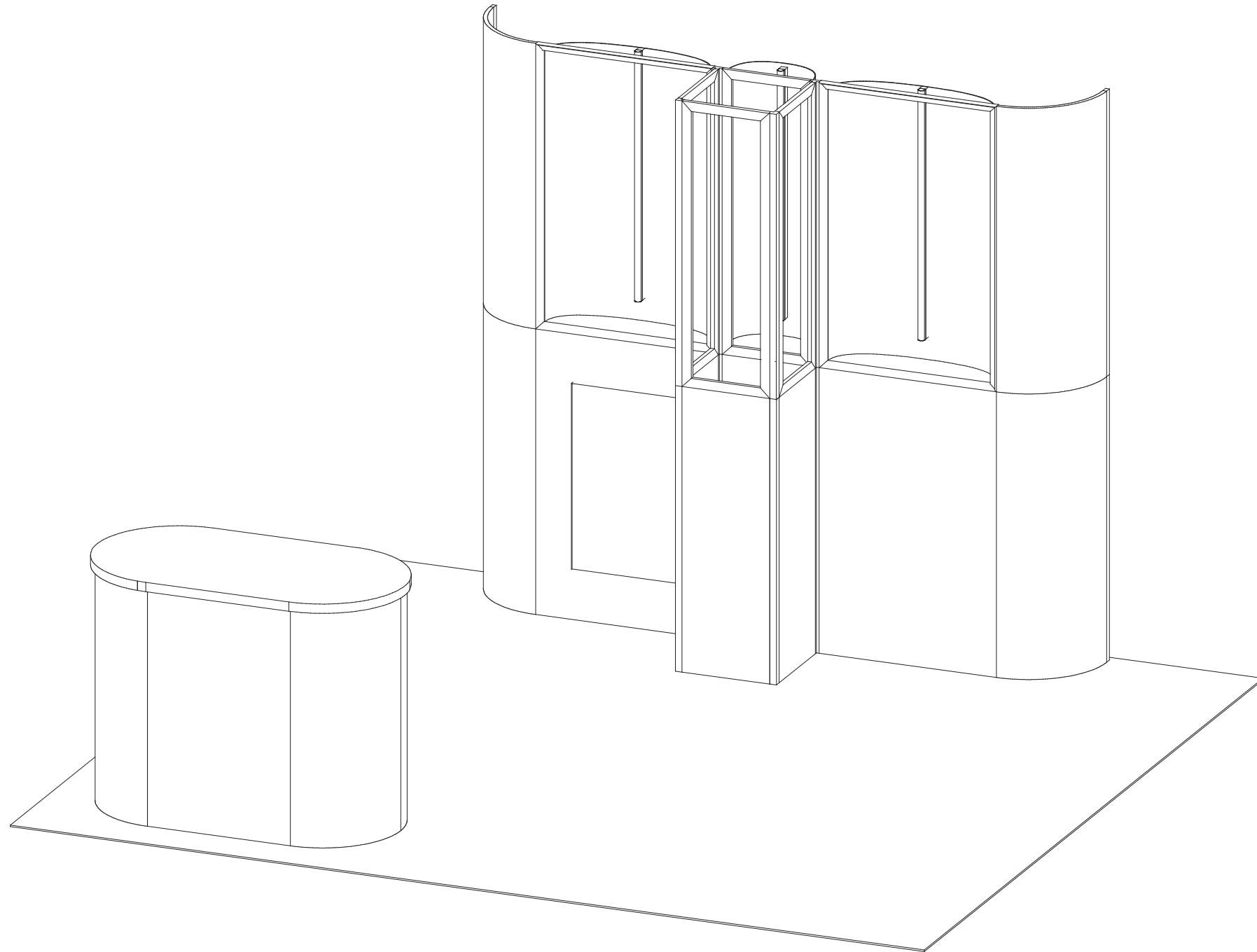

# euro It | HYBRIDS

## Euro LT Hybrids General Setup Instructions

### Using Your Setup Instructions

The Euro LT Hybrids Setup Instructions are created specifically for your configuration. They are laid out sequentially in levels, including exploded views, and a logical series of detailed steps to assemble the main structure and components. We encourage you to study the instructions **before** attempting to assemble your exhibit.

### Cleaning and Packing Your Display

- 1) When cleaning laminate countertops or panels use mild cleansers and a soft material such as cotton.
- 2) Keep all display components away from extreme heat and long exposure to sunlight to avoid warping and fading.
- 3) Retain all packing material. It will make re-packing much easier and will reduce the likelihood of shipping damage.

Level 1 = Blue  
 Level 2 = Red  
 Level 3 = Green  
 Level 4 = Black

#### Color Code

The top clip is color coded to distinguish the level. The color coded clip also contains the numbered label

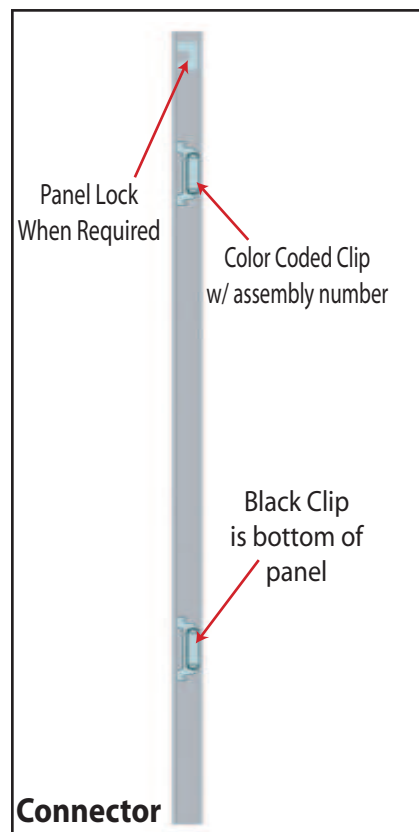

Each component has 2 clips, the lower clip is ALWAYS black..

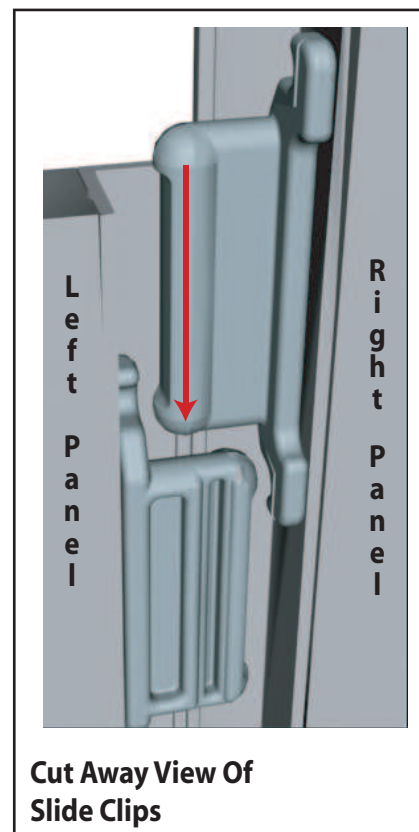

Components connect together by aligning them and sliding downward connecting clips together.

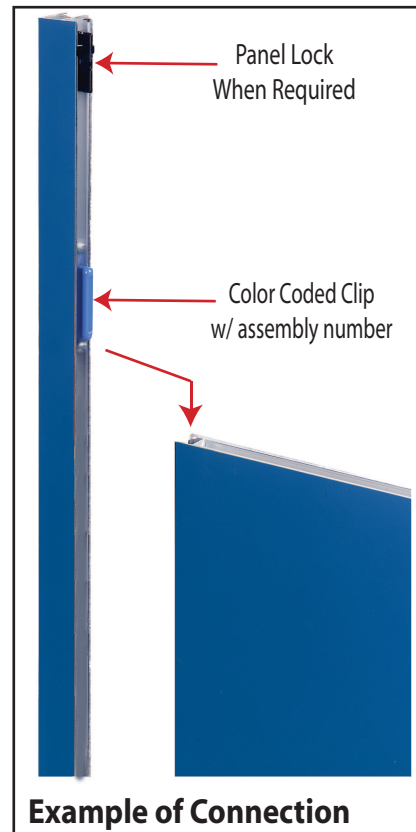

Configurations are assembled from left to right, usually starting with #1 and following the numbered sequence.

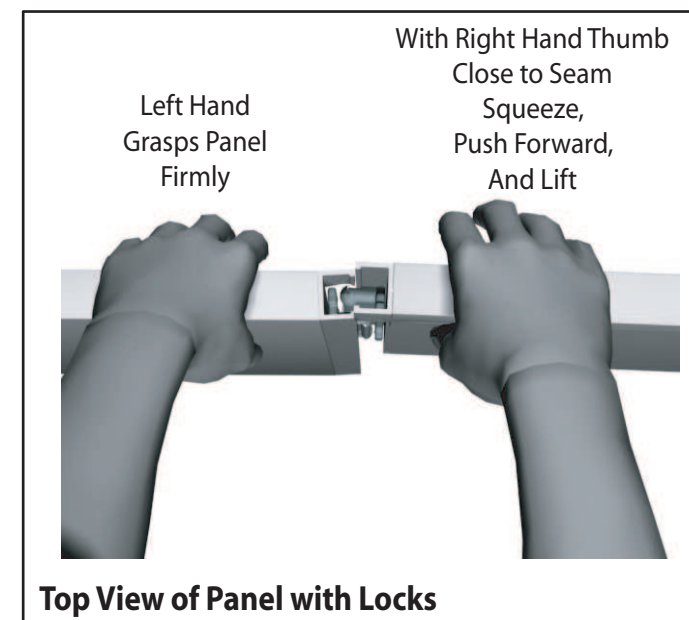

The first level of components contains panel locks that are located at the top of the panel for extra stability and a seamless connection. When disassembling panels, twist top connection slightly and lift right panel upward.

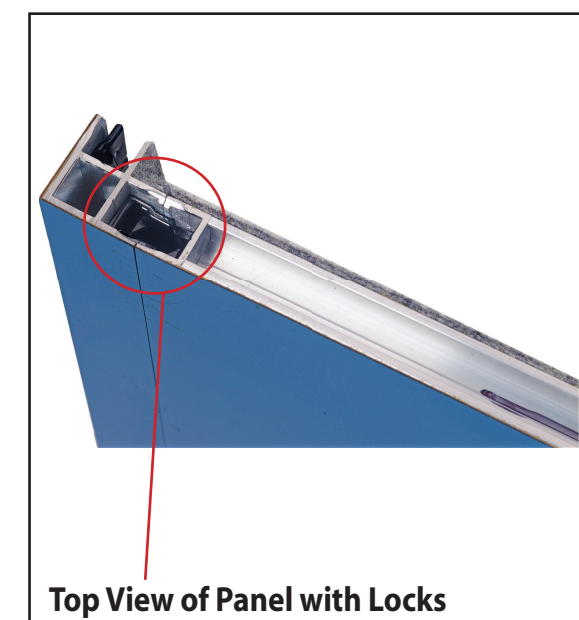

866.652.2100

| Item Number | Description                                |
|-------------|--|
| 1           | 46" h End Cap                              |
| 2           | 11.5" r x 46" h Quarter Curve panel        |
| 3           | 28.5" w x 46" h Flat Panel w/ Cut out Hole |
| 4           | 46" h T Connector                          |
| 5           | 14.125" w x 46" h Flat Panel               |
| 6           | 14.125" w x 46" h Flat Panel w/ Wood Fill  |
| 7           | 46" h 90° Connector                        |
| 8           | 14.125" w x 46" h Flat Panel               |
| 9           | 46" h 90° Connector                        |
| 10          | 14.125" w x 46" h Flat Panel w/ Wood Fill  |
| 11          | 46" h T Connector                          |
| 12          | 28.5" w x 46" h Flat Panel                 |
| 13          | 11.5" r x 46" h Quarter Curve panel        |
| 14          | 46" h End Cap                              |

Steps:  
 1) Assemble by starting at panel #1\* and continue in numerical order.

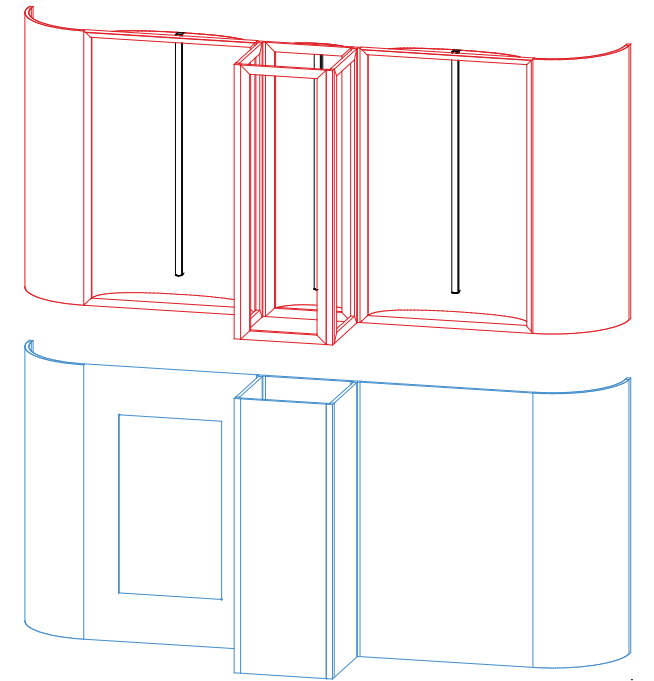

1\*

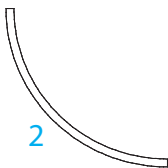

2

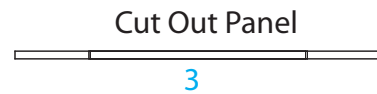

Cut Out Panel

3

4



5

11



12

14

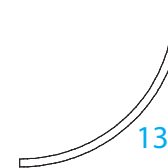

13

6  
Wood Core Panel



7

10  
Wood Core Panel



9



8

| Item Number | Description   |
|-------------|---|
| 1           | 46" h End Cap   |
| 2           | 11.5" r x 46" h Quarter Curve panel                         |
| 3           | 28.5" w x 46" h Window Frame                                |
| 4           | 46" h T Connector w/ Pins Attached to Inside of Connector   |
| 5           | 14.125" w x 46" h Window Frame                              |
| 6           | 14.125" w x 46" h Window Frame                              |
| 7           | 46" h 90° Connector w/ Pins Attached to Inside of Connector |
| 8           | 14.125" w x 46" h Window Frame                              |
| 9           | 46" h 90° Connector w/ Pins Attached to Inside of Connector |
| 10          | 14.125" w x 46" h Window Frame w/ Door                      |
| 11          | 46" h T Connector w/ Pins Attached to Inside of Connector   |
| 12          | 28.5" w x 46" h Window Frame                                |
| 13          | 11.5" r x 46" h Quarter Curve panel                         |
| 14          | 46" h End Cap   |

Steps:

1) Assemble by starting at panel #1\* and continue in numerical order.

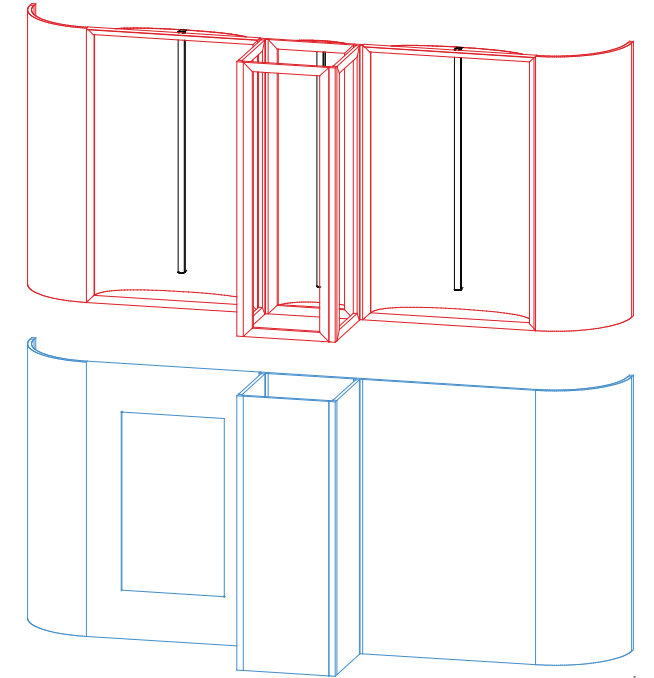

**Light Box Assembly**

Step 1: Making sure that velcro is facing to the front of the booth bend reflector and attach hinged portion to velcro attached to back of light box frame.

Step 2: Place light bars on velcro strips. Please note as every graphic is different some position adjustment may need to be made for optimum results.

Step 3: Using magnetic tape place graphic onto inside flange of frame.

1\*

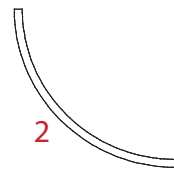

2

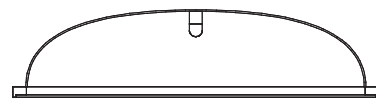

3

4

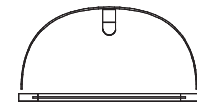

5

11

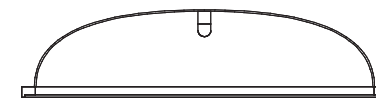

12

13

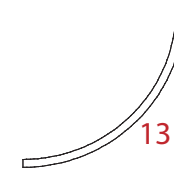

6



10



Door

7



8

9

14

866.652.2100

| Item Number | Description                   |
|-------------|-------------------------------|
| 15          | 19"w x 38"h Flat Panel        |
| 16          | 38"h Curved Panel             |
| 17          | 38"h Curved Panel             |
| 18          | 19"w x 38"h Flat Panel w/Door |
| 19          | 38"h Curved Panel             |
| 20          | 38"h Curved Panel             |

Steps:

1) Connect panels together in numerical order as shown in illustrations.

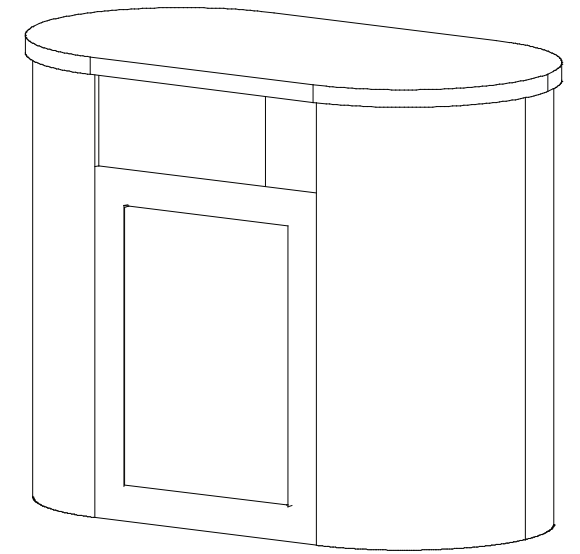

Set Counter atop assembled Pedestal.

