

# euro It | HYBRIDS

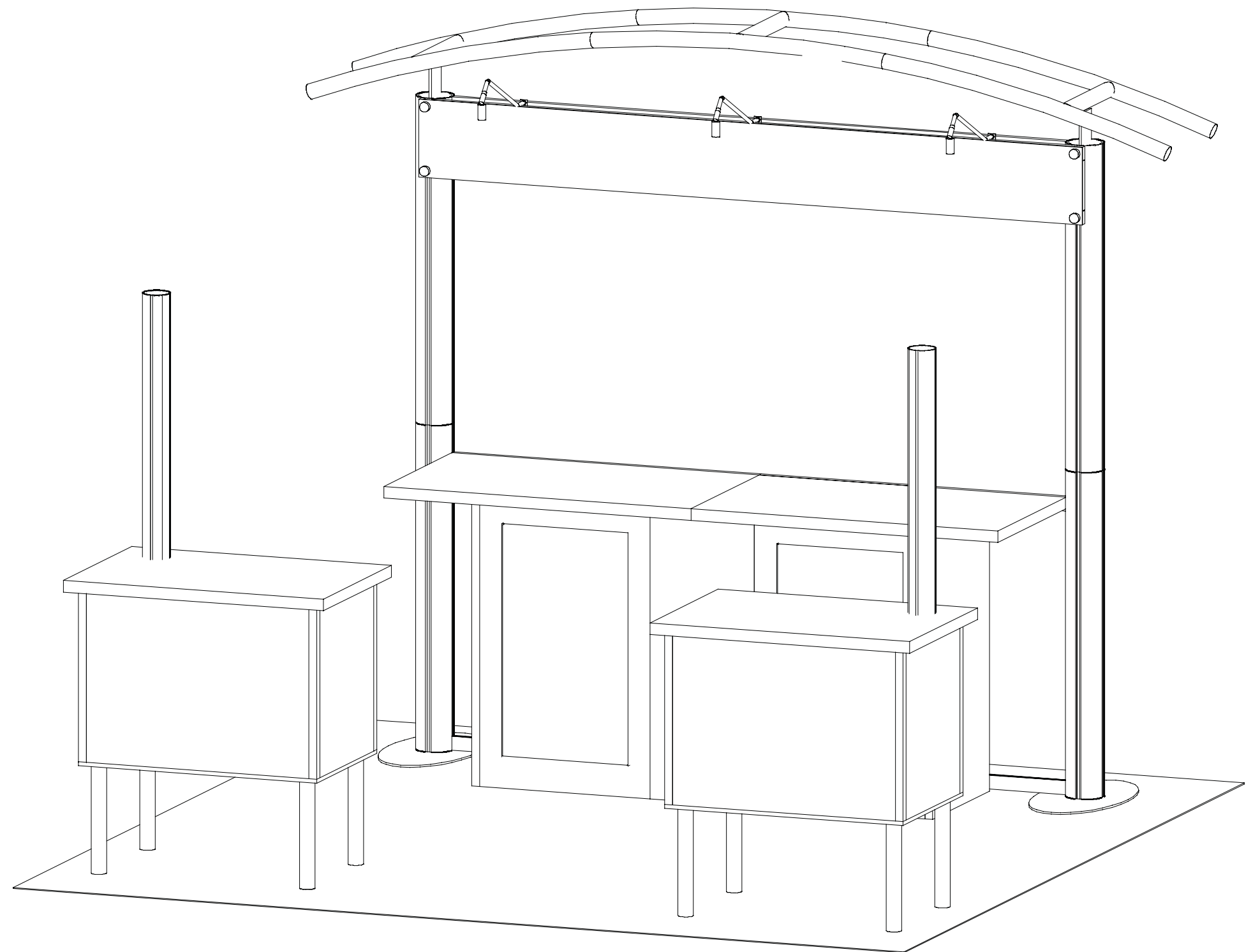
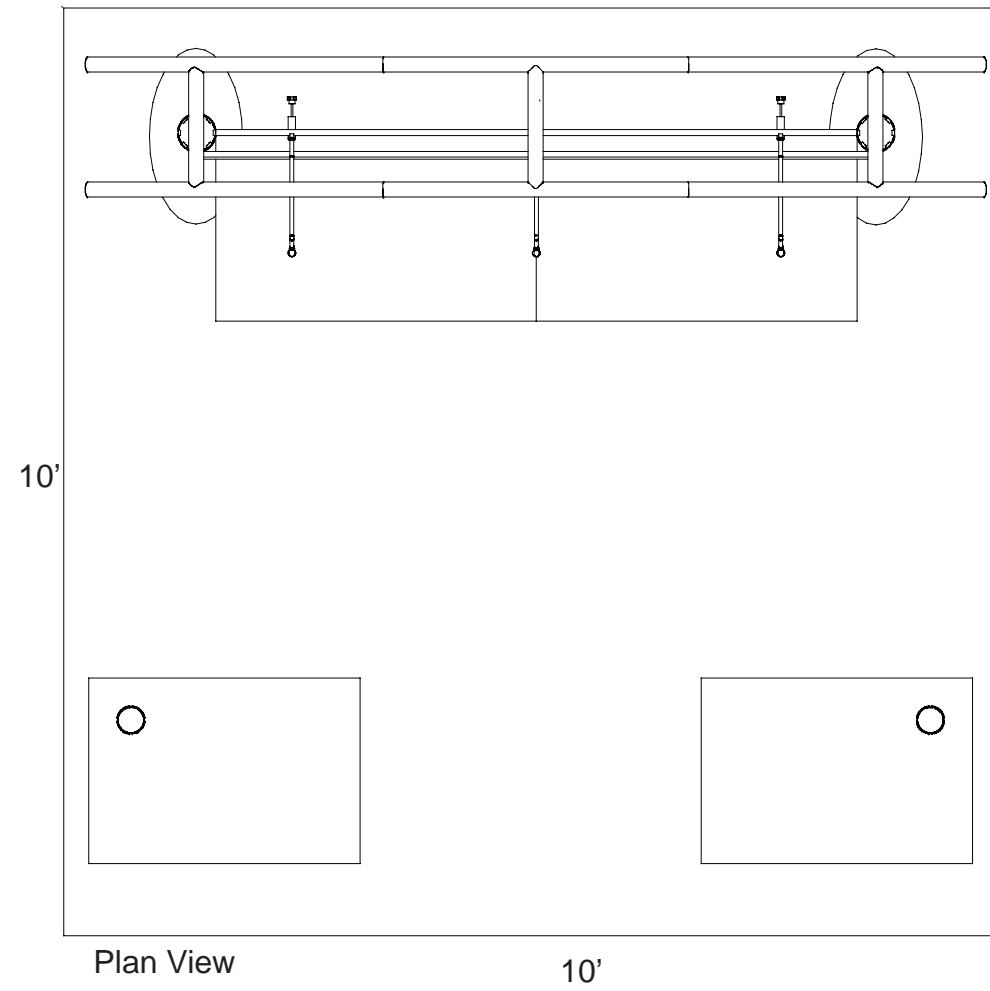

WHEN DISASSEMBLING ALUMINUM EXTRUSION, TIGHTEN ALL SETSCREWS AND LOCKS TO PREVENT LOSS DURING SHIPPING

# euro lt | HYBRIDS

## Using Your Setup Instructions

The Euro LT Hybrids Setup Instructions are created specifically for your configuration. They are laid out sequentially in levels, including exploded views, and a logical series of detailed steps to assemble the main structure and components. We encourage you to study the instructions **before** attempting to assemble your exhibit.

Each page reminds you to tighten the setscrews after disassembling your exhibit to prevent loss of the locks and setscrews (see below in RED). This is VERY IMPORTANT.

## Cleaning and Packing Your Display

- 1) Use care when cleaning aluminum extrusion or acrylic inserts. Use only non-abrasive cleaners.
- 2) When cleaning laminate inserts, countertops, or panels use mild cleansers and a soft material such as cotton.
- 3) Keep all display components away from extreme heat and long exposure to sunlight to avoid warping and fading.
- 4) Retain all packing material. It will make re-packing much easier and will reduce the likelihood of shipping damage.

## General Setup Instructions for Extrusion System



The Tool

Most exhibits can be assembled with the supplied Hex Key Tool. Occasionally, a flat head screwdriver may be required.



Typical Connection

Most horizontal extrusion connections have a patented expandable lock. This lock inserts into the groove of an opposing extrusion. Tightening the lock with the Hex Key Tool expands the lock and creates a strong positive connection.



Typical Connection (cont'd)

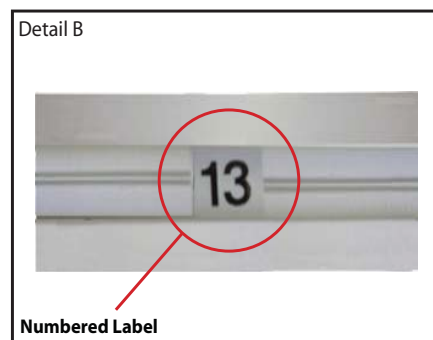

Numbered Label

Each extrusion contains a numbered label which corresponds with setup instructions. The label is located within a groove of the extrusion (when possible). With extrusion components the labels contain Black numbers unless otherwise specified.



Horizontal Inline Connection (remove only one setscrew)

Remove only (1) setscrew when disassembling. Replace setscrew in extrusion after assembling it. Before packing, replace setscrew in extrusion to avoid losing it.

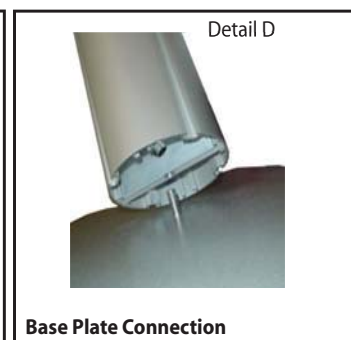

Base Plate Connection

Attach base plate to round or square vertical extrusion using the bolt provided. Be careful not to strip the threads.

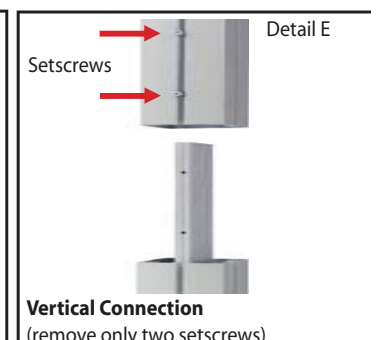

Vertical Connection (remove only two setscrews)

When vertical extrusions are packed in portable cases rather than crates or tubs, they must be broken down into smaller section which then require assembly.

Remove only (2) setscrews when disassembling. Replace setscrews in extrusion after assembling it. Before packing, replace setscrews in extrusion to avoid losing them.

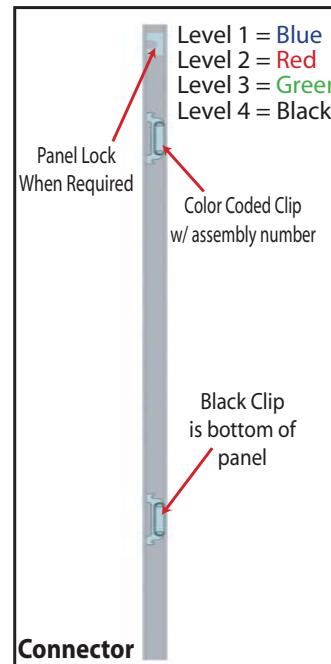

Connector

Each component has 2 clips, the lower clip is ALWAYS black. The top clip is color coded to distinguish which level. The color coded clip also contains the numbered label.

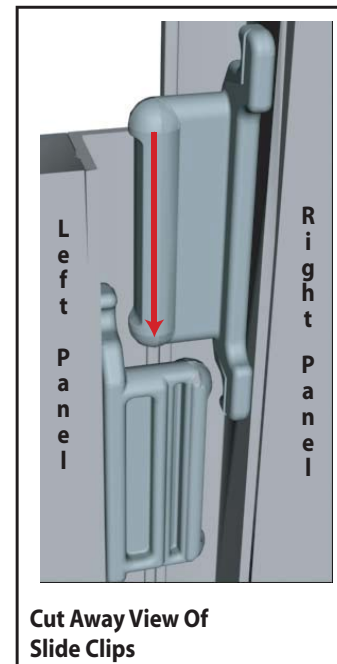

Cut Away View Of Slide Clips

Components connect together by aligning them and sliding downward connecting clips together.

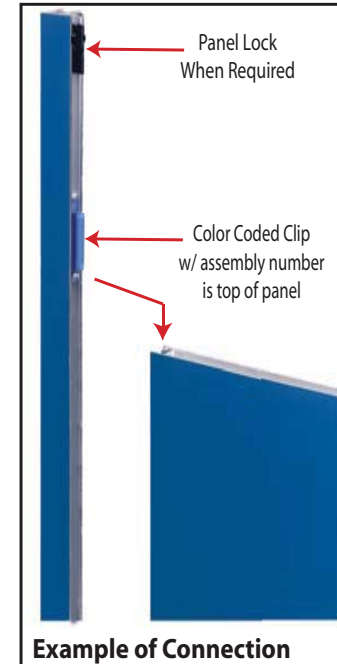

Example of Connection

Configurations are assembled from left to right, usually starting with #1 and following the numbered sequence.

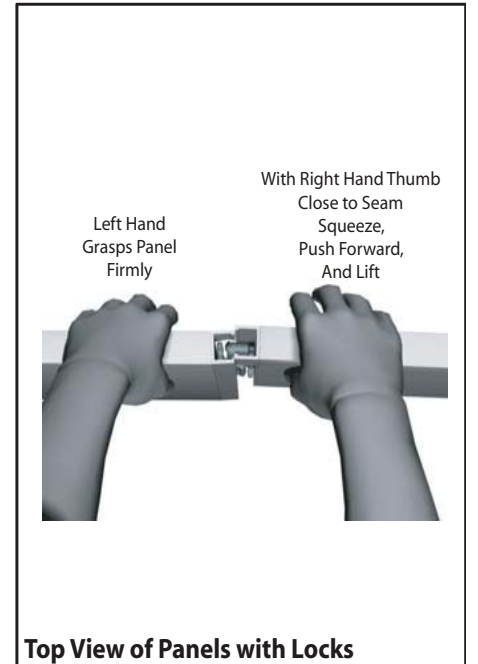

Top View of Panels with Locks

The first level of components contain panel locks that are located at the top of the panel for extra stability and seamless connection. When disassembling panels twist top connection slightly and lift right panel upward.

**WHEN DISASSEMBLING ALUMINUM EXTRUSION, TIGHTEN ALL SETSCREWS AND LOCKS TO PREVENT LOSS DURING SHIPPING**

866.652.2100

Part Number	Qty	Description
1	2	Base Plates
2	2	42" h Lower Vertical extrusion
3	2	42" h Upper Vertical extrusion
3a	2	Extrusion Cap w/ Canopy Connection
4a/4b	1/1	41.3596" Lower Horizontal w/ Velcro attached to Back of extrusion
5a/5b	1/1	41.3596" Middle Horizontal extrusion
6a/6a	1/1	41.3596" Upper Horizontal w/ Velcro attached to Back of extrusion

Steps

- 1) Attach Vertical extrusions [2] to the Oval base plates [1].
- 2) Attach Upper Vertical extrusions [3] atop of Lower Vertical extrusions [2].
- 3) Assemble all Horizontal extrusions [4a to 4b, 5a to 5b, and 6a to 6b].
- 4) Attach Lower Horizontal assemblies [4a/4b] between Vertical assemblies [2/3] as shown.  
note: Velcro on Lower Horizontals must face towards BACK.
- 5) Attach Middle Horizontal assemblies [5a/5b] between Vertical assemblies [2/3] as shown.  
note: Holes on Niddle Horizontals must face front for Counter attachment.
- 6) Attach Upper Horizontal assemblies [6a/6b] between Vertical assemblies [2/3] as shown.  
note: Velcro on Upper Horizontals must face towards BACK.
- 7) Place extrusion cap atop verticals for Canopy connection.

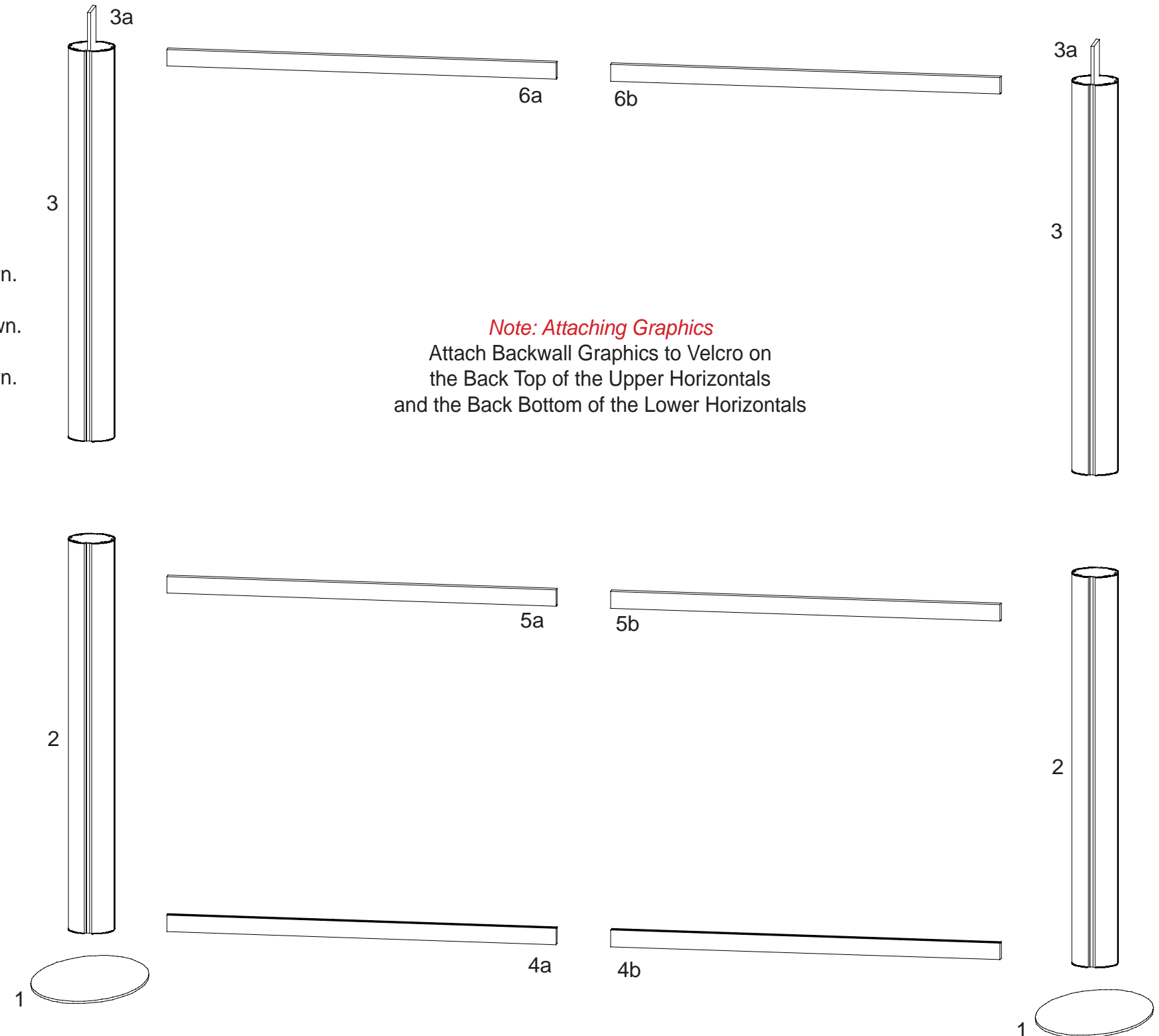

WHEN DISASSEMBLING ALUMINUM EXTRUSION, TIGHTEN ALL SETSCREWS AND LOCKS TO PREVENT LOSS DURING SHIPPING

Part Number	Qty	Description
7a/7b	1/1	44.6871" h Lower Horizontal extrusion
8a/8b	1/1	44.6871" h Upper Horizontal extrusion
9	2	6.4173" Vertical extrusion

Steps

- 1) Assemble all Horizontal extrusions [7a to 7b and 8a to 8b].
- 2) Attach Vertical extrusion [9] between Horizontal assemblies [7a/7b and 8a/8b].
- 3) Attach Sintra to assembled Header and Backwall using Standoff Caps provided by screwing them into the V20 located in the Round Vertical.
- 4) Attach Lights as shown.

Step 3) V20 Connection

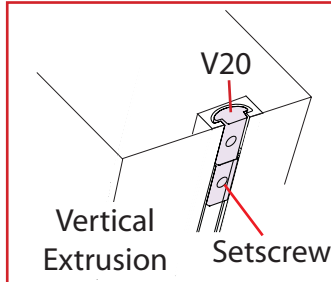

V20 Slides into groove of vertical extrusion then tightens into place by tightening the setscrew.

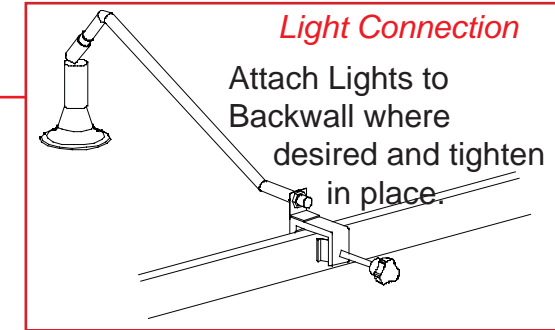
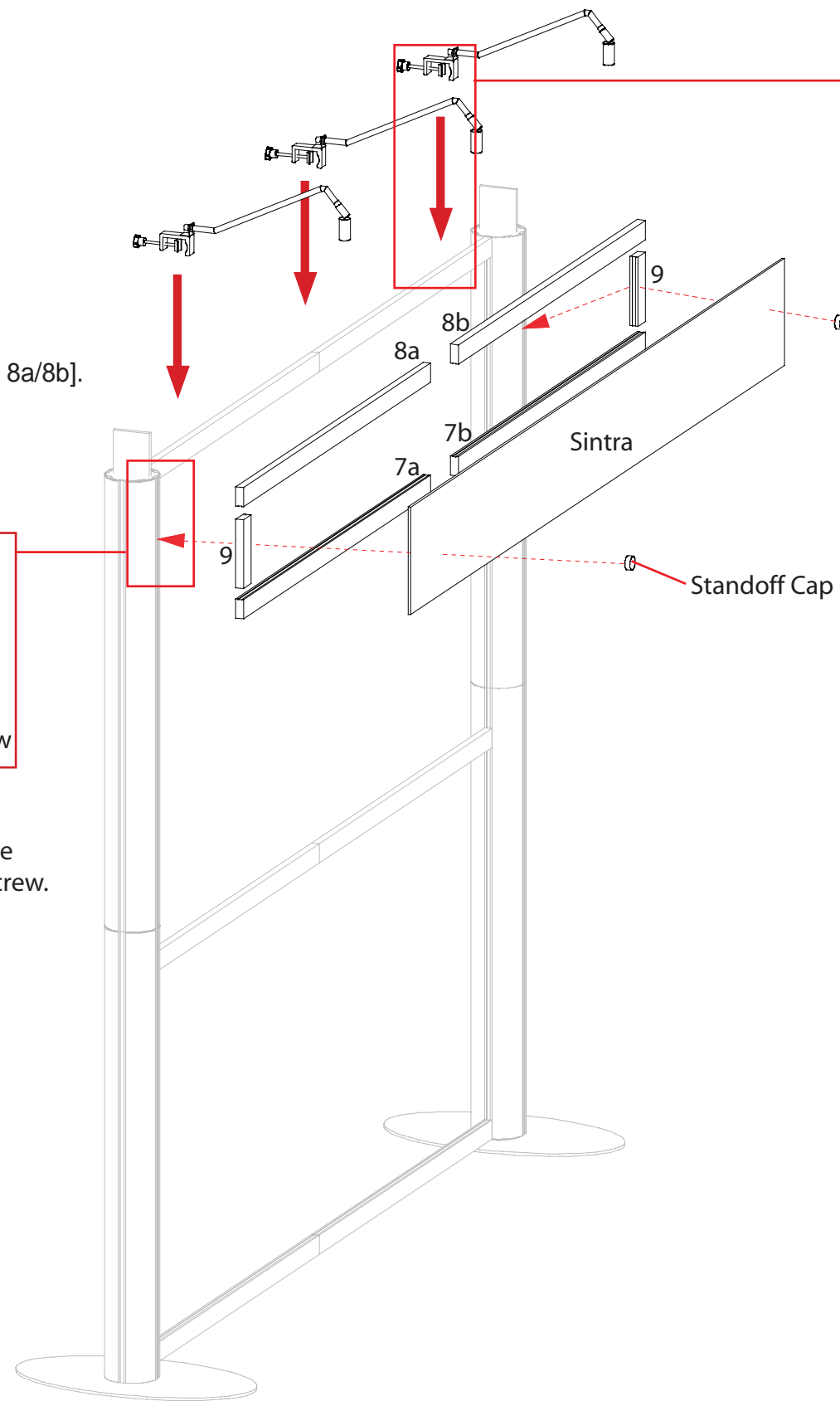

**WHEN DISASSEMBLING ALUMINUM EXTRUSION, TIGHTEN ALL SETSCREWS AND LOCKS TO PREVENT LOSS DURING SHIPPING**

Item	Quantity	Description
A	1	39" Round formed extrusion
AB	1	39" Round formed extrusion
B	1	39" Round fomred extrusion
C	1	39" Round formed extrusion
CD	1	39" Round formed extrusion
D	1	39" Round formed extrusion
E	2	14" Round extrusion
F	1	14" Round extrusion

Steps:

- 1) Connect 39" (A) round formed extrusion to 39" (A) round formed extrusion.
- 2) Connect 39" (B) round formed extrusion to 39" (B) round formed extrusion.
- 3) Connect 39" (C) round formed extrusion to 39" (C) round formed extrusion.
- 4) Connect 39" (D) round formed extrusion to 39" (D) round formed extrusion.
- 5) Connect (A) round formed extrusion and (D) round formed extrusion to 14" (E) extrusion.
- 6) Connect (B) round formed extrusion and (C) round formed extrusion to 14" (E) extrusion.
- 7) Connect (AB) round formed extrusion and (CD) round formed extrusion to 14" (F) extrusion.
- 8) Attach Canopy Assembly to Vertical extrusions with Canopy attachments.

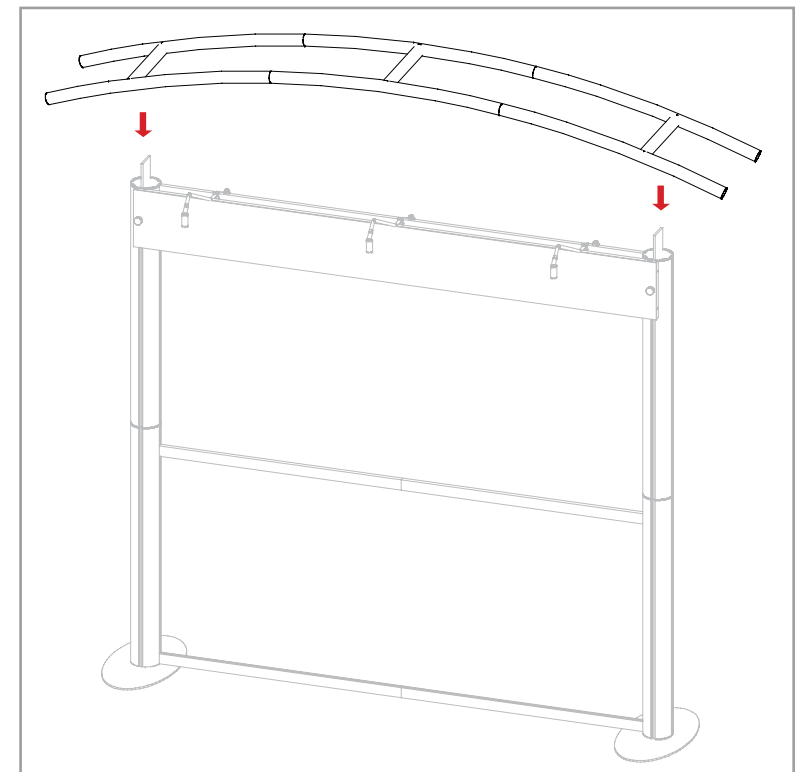
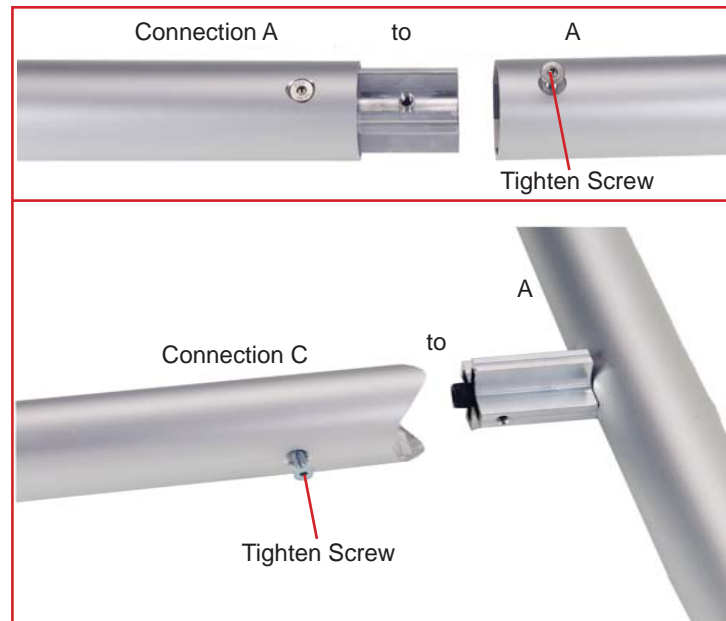
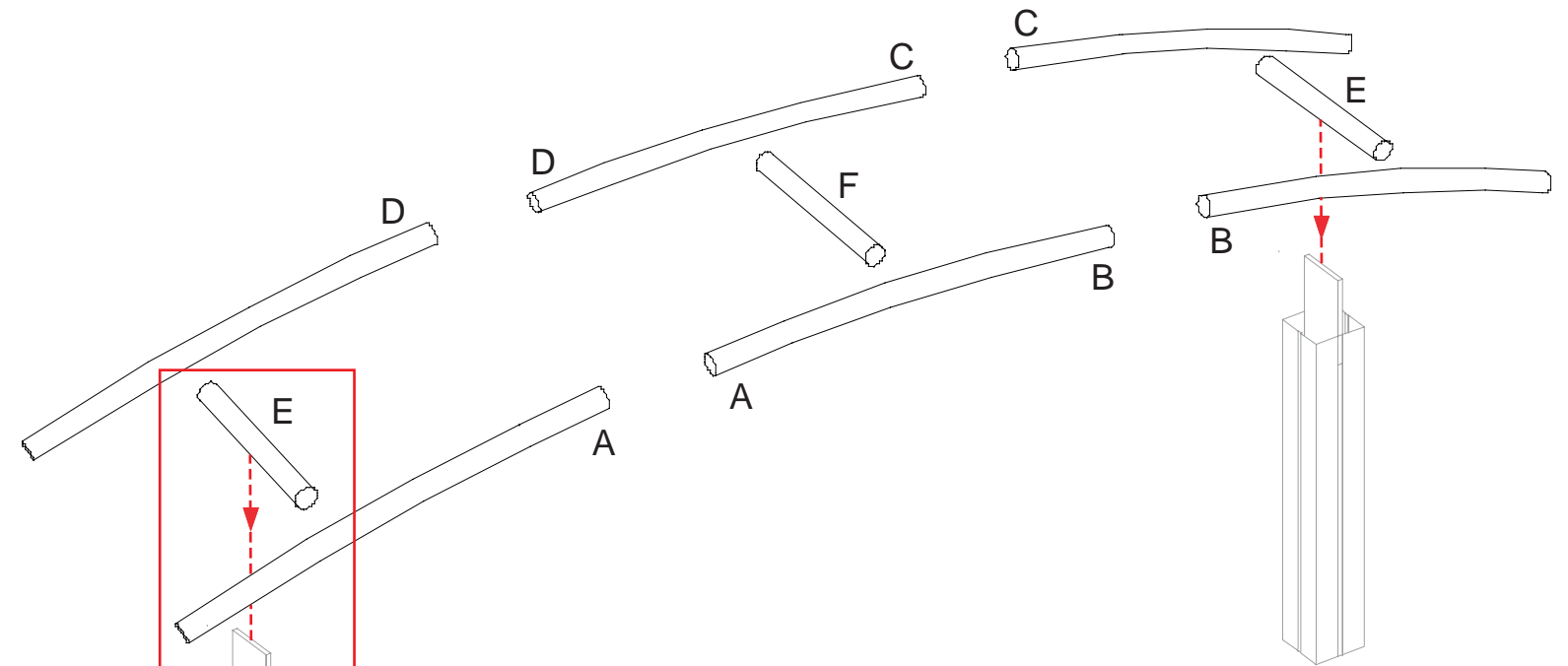

**WHEN DISASSEMBLING ALUMINUM EXTRUSION, TIGHTEN ALL SETSCREWS AND LOCKS TO PREVENT LOSS DURING SHIPPING**

866.652.2100

Part Number	Description
1	19" w x 38" h Flat Panel
2	38" h 90° Connector
3	23" w x 38" h Flat Door Panel
4	14.125" w x 38" h Flat Panel
5	23" w x 38" h Flat Door Panel
6	38" h 90° Connector
7	19" w x 38" h Flat Panel

Assemble panels in numerical order starting with #1.

Assembled panels should but up against backwall and counter attaches to middle horizontal extrusion using hardware provided.

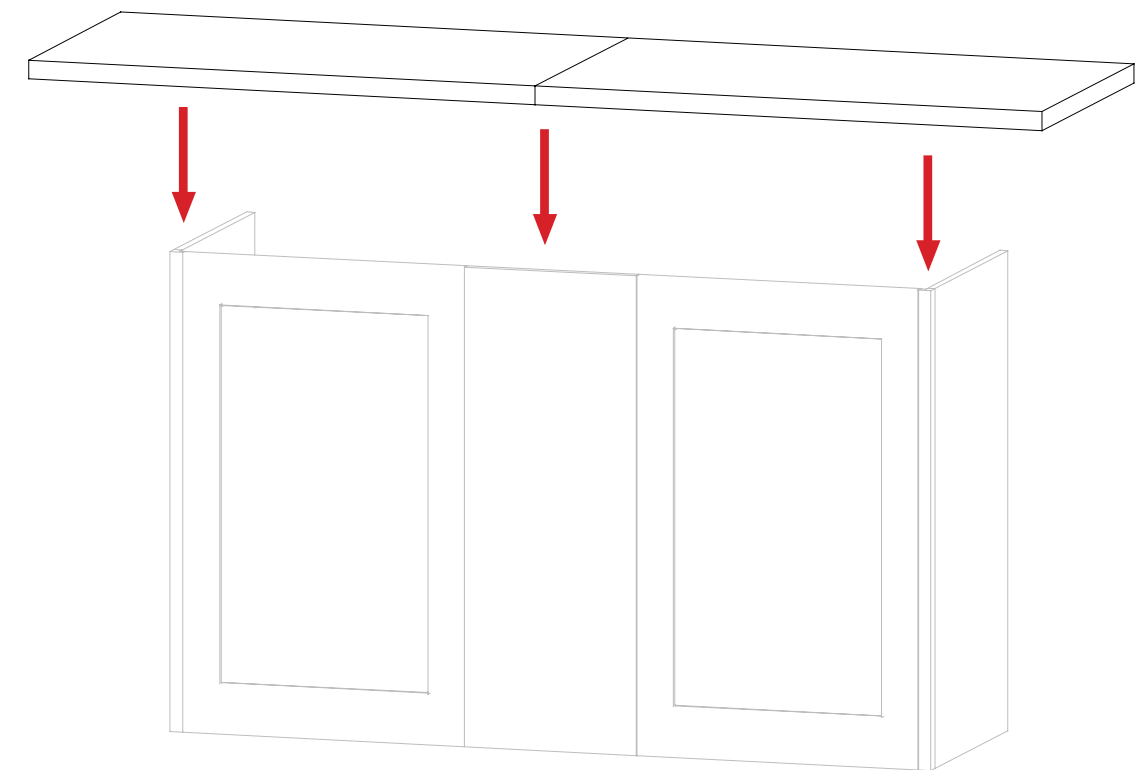
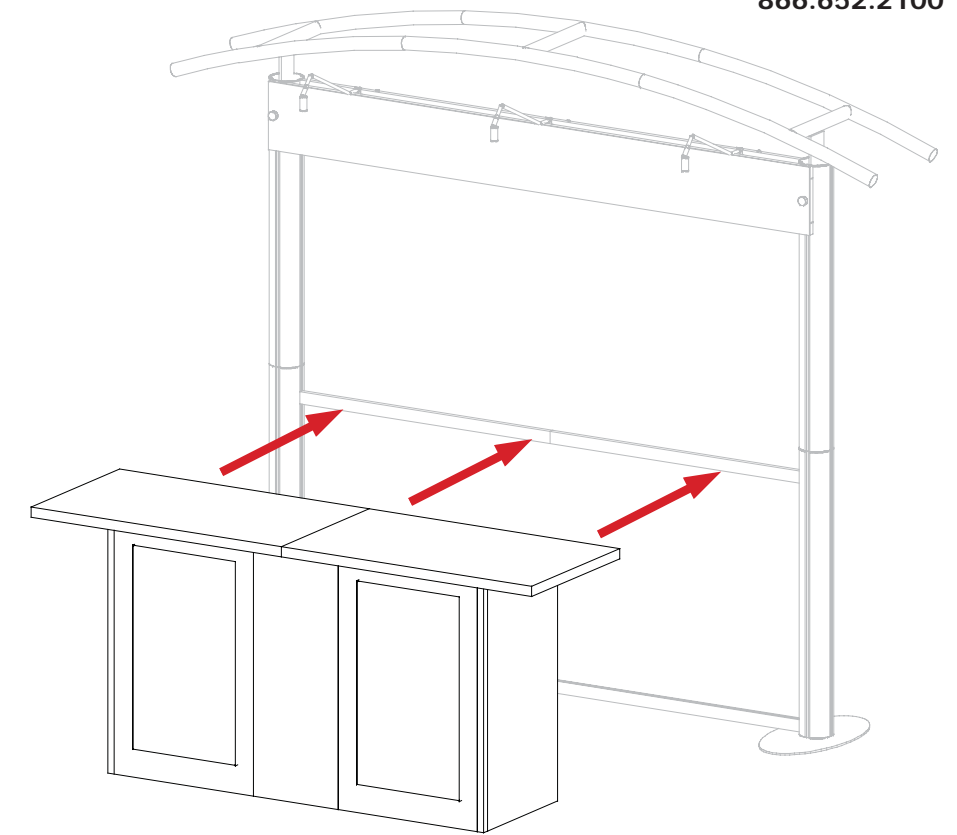

**WHEN DISASSEMBLING ALUMINUM EXTRUSION, TIGHTEN ALL SETSCREWS AND LOCKS TO PREVENT LOSS DURING SHIPPING**

866.652.2100

Part Number	Description
8	19" w x 23" h Flat Panel
9	23" h 90° Connector
10	30" w x 23" h Flat Door Panel
16	30" w x 23" h Flat Panel
17	23" h 90° Connector
18	23" h 90° Connector
19	19" w x 23" h Flat Panel
20	23" h 90° Connector
11A	14" h Round Extrusion
12A	44" h Round Extrusion

- 1) Attach vertical extrusions [10] to Floor by screwing into place.
- 2) Assemble panels in numerical order starting with #8 atop of assembled floor section.
- 3) Place Counter atop assembled Pedestal.
- 4) Assemble extrusions 11A to 12A and slide through Counter Top and attach to Floor.

**EX: MONITOR MOUNT**  
 Attach monitor mount to vertical extrusions after assembly.

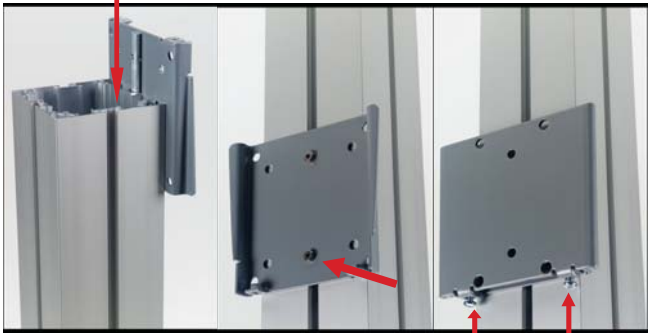

Slide Mount into Groove of Vertical Extrusion. Tighten Setscrew. Attach top Plate and tighten screws.

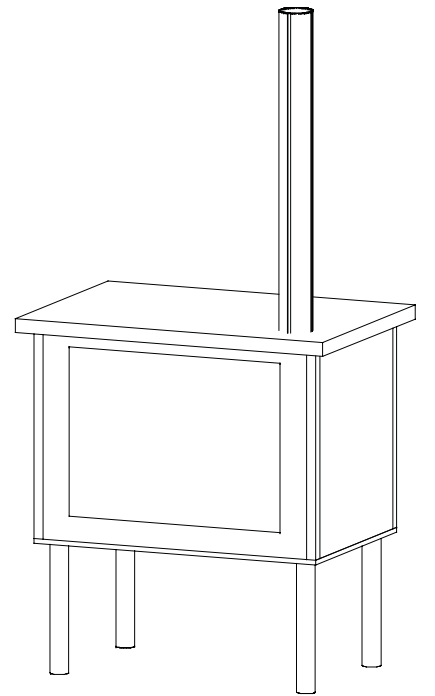
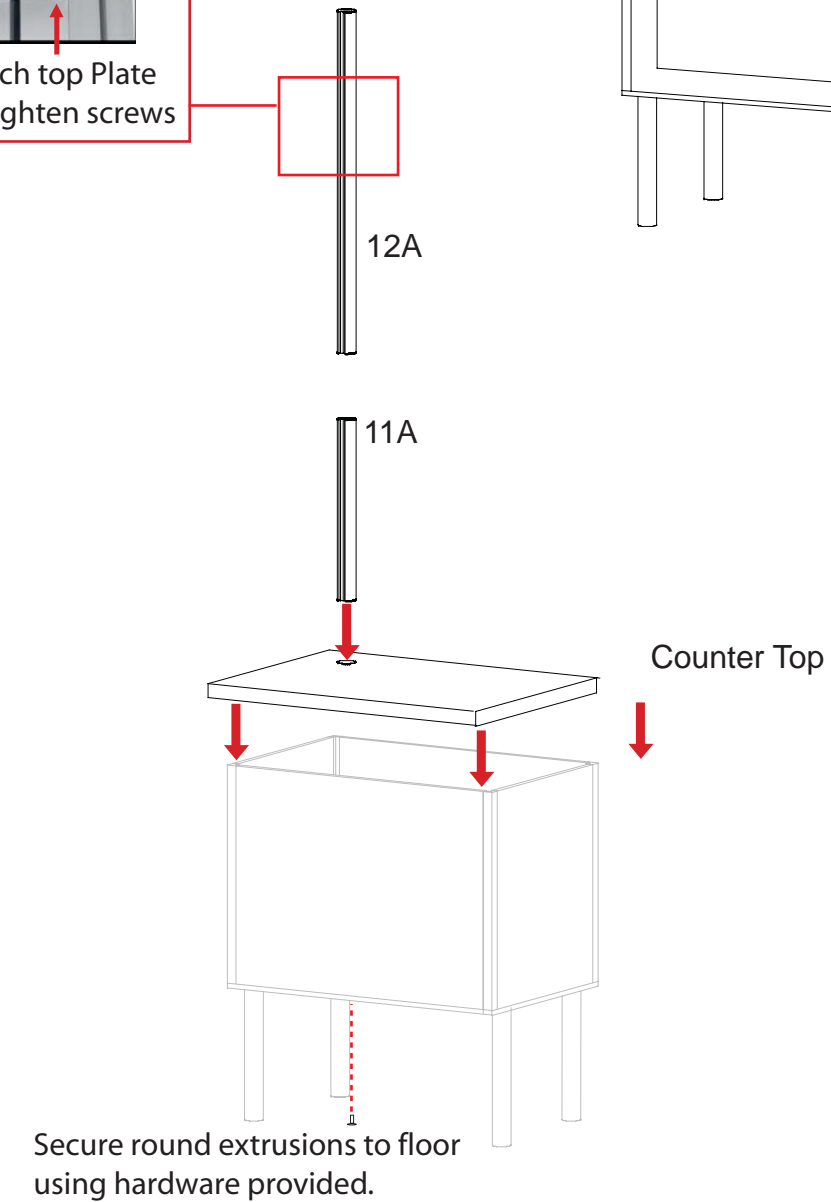
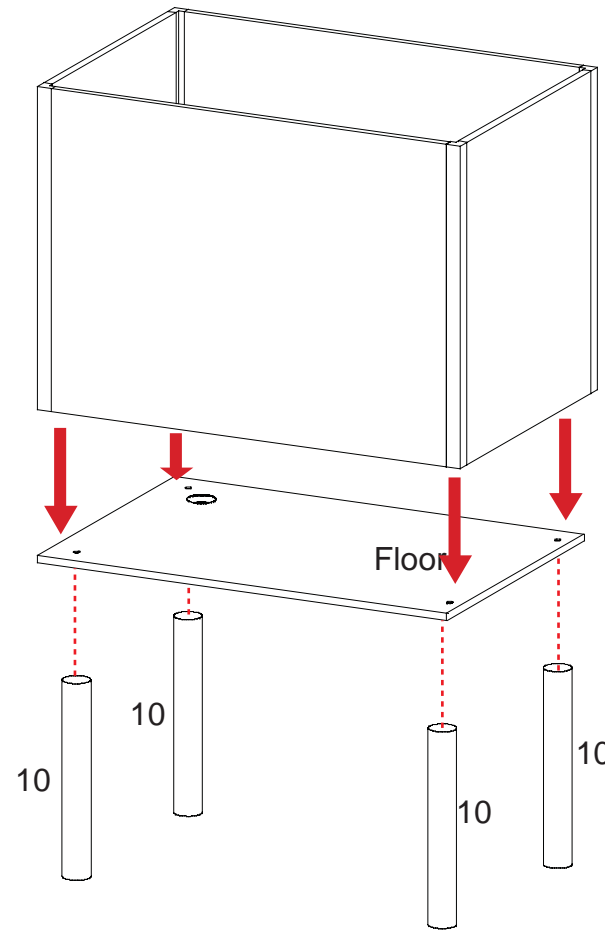
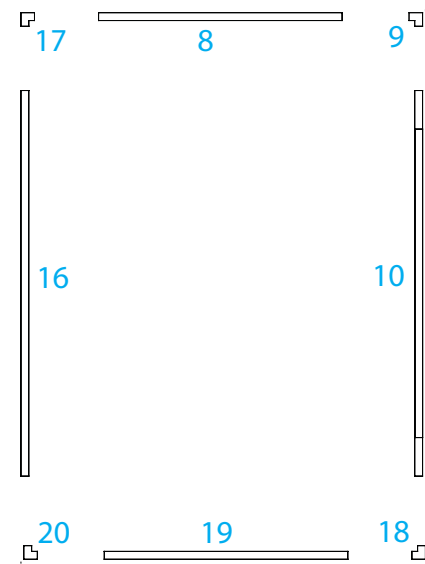

**WHEN DISASSEMBLING ALUMINUM EXTRUSION, TIGHTEN ALL SETSCREWS AND LOCKS TO PREVENT LOSS DURING SHIPPING**

Part Number	Description
11	30" w x 23" h Flat Door Panel
12	23" h 90° Connector
13	19" w x 23" h Flat Panel
14	23" h 90° Connector
15	30" w x 23" h Flat Panel
21	23" h 90° Connector
22	19" w x 23" h Flat Panel
23	23" h 90° Connector
11A	14" h Round Extrusion
12A	44" h Round Extrusion

- 1) Attach vertical extrusions [10] to Floor by screwing into place.
- 2) Assemble panels in numerical order starting with #11 atop of assembled floor section.
- 3) Place Counter atop assembled Pedestal.
- 4) Assemble extrusions 11A to 12A and slide through Counter Top and attach to Floor.

**EX: MONITOR MOUNT**  
 Attach monitor mount to vertical extrusions after assembly.

Slide Mount into Groove of Vertical Extrusion.    Tighten Setscrew    Attach top Plate and tighten screws

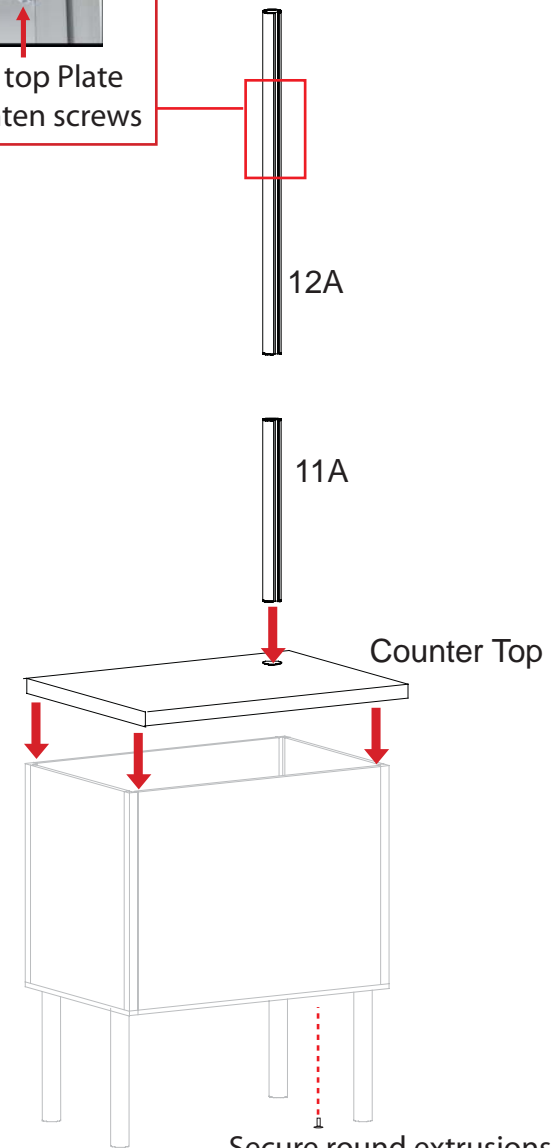
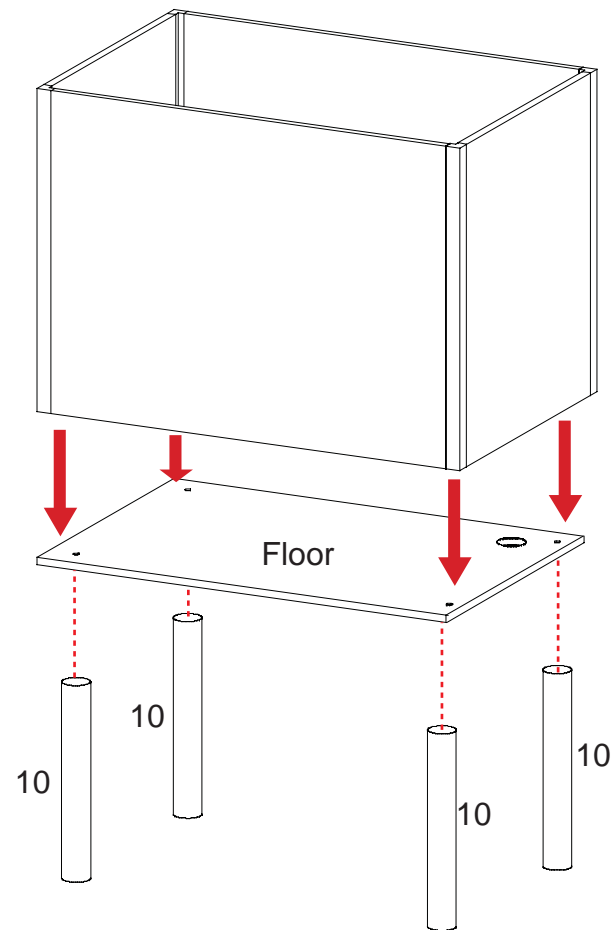
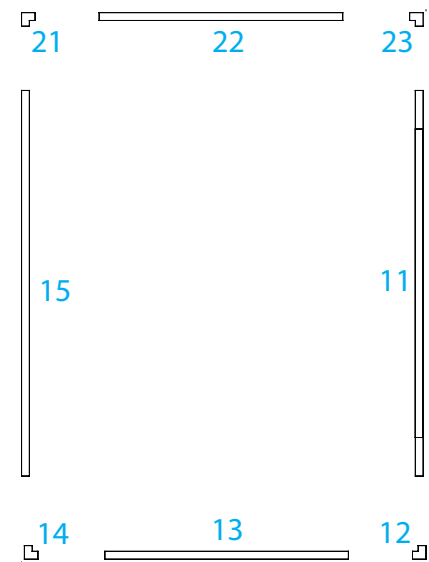

Secure round extrusions to floor using hardware provided.

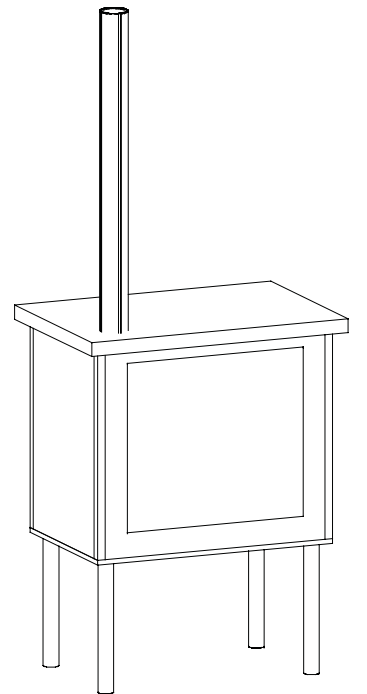

**WHEN DISASSEMBLING ALUMINUM EXTRUSION, TIGHTEN ALL SETSCREWS AND LOCKS TO PREVENT LOSS DURING SHIPPING**