

WHEN DISASSEMBLING ALUMINUM EXTRUSION, TIGHTEN ALL SETSCREWS AND LOCKS TO PREVENT LOSS DURING SHIPPING

visionary™ IDESIGNS

Using Your Setup Instructions

The Visionary Designs Setup Instructions are created specifically for your configuration. They are laid out sequentially, including an exploded view of the entire display, and then a logical series of detailed steps to assemble the main structure and components. We encourage you to study the instructions **before** attempting to assemble your exhibit.

Each page reminds you to tighten the setscrews after disassembling your exhibit to prevent loss of the locks and setscrews (see below in RED). This is **VERY IMPORTANT**.

Cleaning and Packing Your Display

- 1) Use care when cleaning aluminum extrusion or acrylic inserts. Use only non-abrasive cleaners.
- 2) When cleaning laminate inserts or countertops, use mild cleansers and a soft material such as cotton.
- 3) Keep all display components away from extreme heat and long exposure to sunlight to avoid warping and fading.
- 4) Retain all packing material. It will make re-packing much easier and will reduce the likelihood of shipping damage.



The Tool

Most Visionary Designs exhibits can be assembled with the supplied Hex Key Tool. Occasionally, a flat head screwdriver may be required.



Detail A

Typical Connection

Most horizontal extrusion connections have a patented expandable lock. This lock inserts into the groove of an opposing extrusion. Tightening the lock with the Hex Key Tool expands the lock and creates a strong positive connection.



Typical Connection (cont'd)

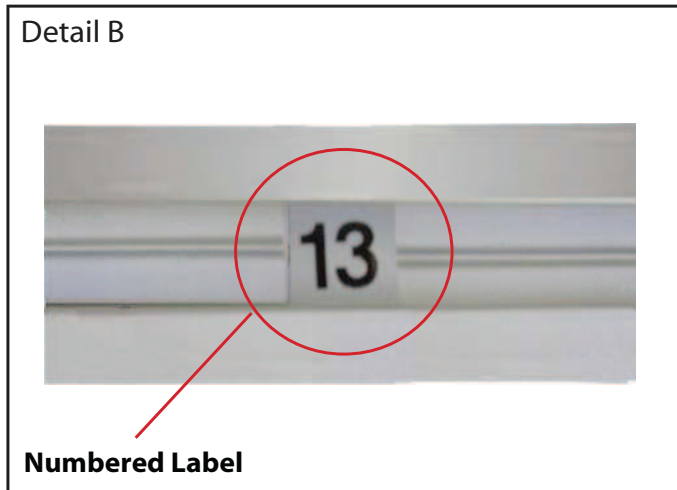

Detail B

Numbered Label

Each extrusion contains a numbered label which corresponds with setup instructions. The label is located within a groove of the extrusion (when possible). With Visionary Designs the labels contain Black numbers unless otherwise specified.



Detail C

Horizontal Inline Connection (remove only one setscrew)

Remove only (1) setscrew when disassembling. Replace setscrew in extrusion after assembling it. Before packing, replace setscrew in extrusion to avoid losing it.

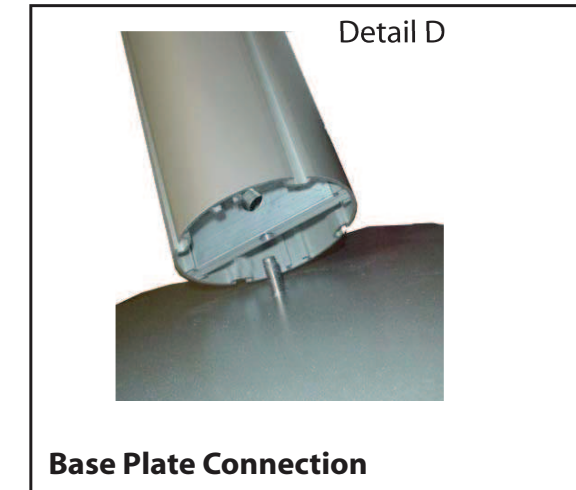

Detail D

Base Plate Connection

Attach base plate to round or square vertical extrusion using the bolt provided. Be careful not to strip the threads.

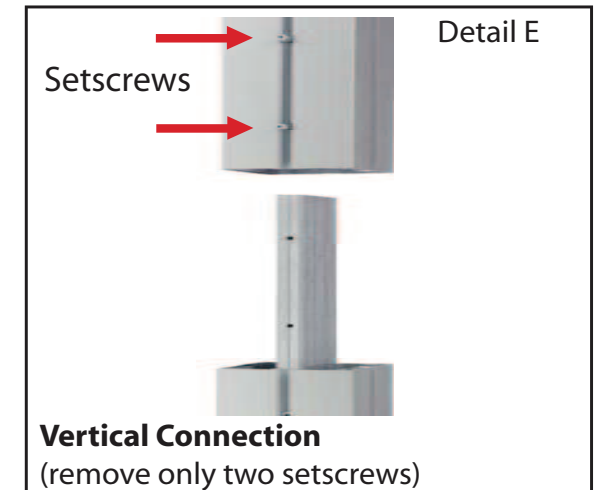

Detail E

Vertical Connection
(remove only two setscrews)

When vertical extrusions are packed in portable cases rather than crates or tubs, they must be broken down into smaller sections which then require assembly.

Remove only (2) setscrews when disassembling. Replace setscrews in extrusion after assembling it. Before packing, replace setscrews in extrusion to avoid losing them.

WHEN DISASSEMBLING ALUMINUM EXTRUSION, TIGHTEN ALL SETSCREWS AND LOCKS TO PREVENT LOSS DURING SHIPPING

866.652.2100

Item	Quantity	Description
1/1A/1B	1/1/1	96”h Vertical Extrusion
2	1	96”h Vertical Extrusion w/ Connection Holes
3	1	96”h Vertical Extrusion w/ Door Hinges
4	1	96”h Vertical Extrusion w/ Wire Management
5	1	96”h Vertical Extrusion w/ Attached Channel
6	3	39.84”w Curved Extrusion

Item	Quantity	Description
7	2	90.54”w Curved Extrusion
8	2	28.61”w Curved Extrusion
9	2	28.61”w Curved Extrusion
10	2	39.35”w Curved Extrusion
11	1	39.35”w Mid Curved Extrusion
12	1	27.9368”w Horizontal Extrusion

Steps:

- 1) Connect Lower horizontal extrusion 6 to 96”h vertical extrusions 1 and 2. Place Laminated insert where indicated.
- 2) Connect Middle and Upper horizontal extrusions 6 to 96”h vertical extrusions 1 and 2, placing Graphic insert where indicated. Attach diffuser to verticals 1 and 2 by velcro and attach lights to diffuser.
- 3) Connect horizontal extrusions 7 to verticals 2 and 3.
- 4) Connect horizontal extrusions 8 to verticals 3 and 4.
- 5) Connect horizontal extrusions 9 to verticals 4 and 1A.
- 6) Connect Lower horizontal extrusion 10 to 96”h vertical extrusions 1A and 1B. Place Laminated insert where indicated.
- 7) Connect Middle and Upper horizontal extrusions 10 to 96”h vertical extrusions 1A and 1B, placing Graphic insert where indicated.

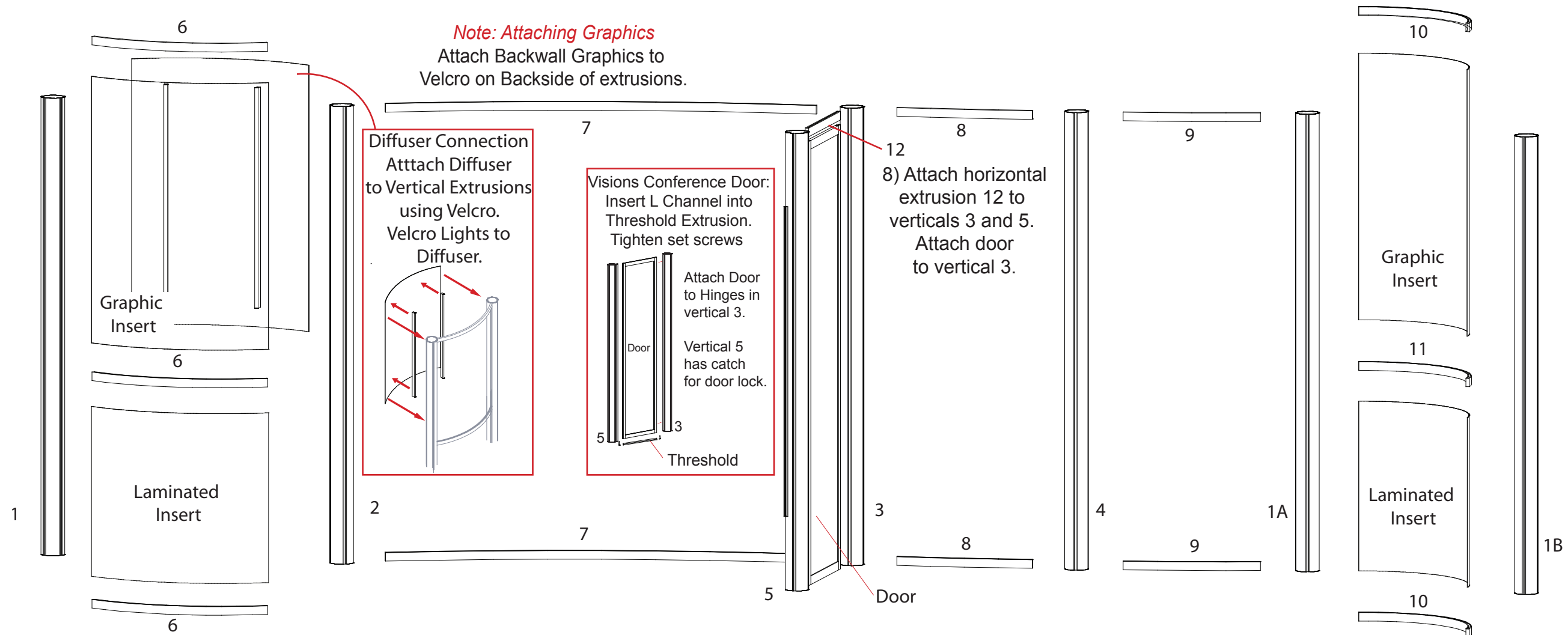

866.652.2100

Item	Quantity	Description
5A	1	96"h Vertical Extrusion w/ attached channel
13	2	39.35"w Curved Extrusion
13A	1	39.35"w Curved Extrusion
14	4	18"w Horizontal Extrusions
15	8	15"w Horizontal Extrusion

Steps:

- 1) Connect horizontal extrusions 13 and 13A to verticals 2 (from previous page) and 5A.
- 2) Connect horizontals 14 between verticals 5 (from previous page) and 5A placing laminated and white inserts where indicated.
- 3) Connect horizontals 15 to verticals 5 placing inserts where indicated.

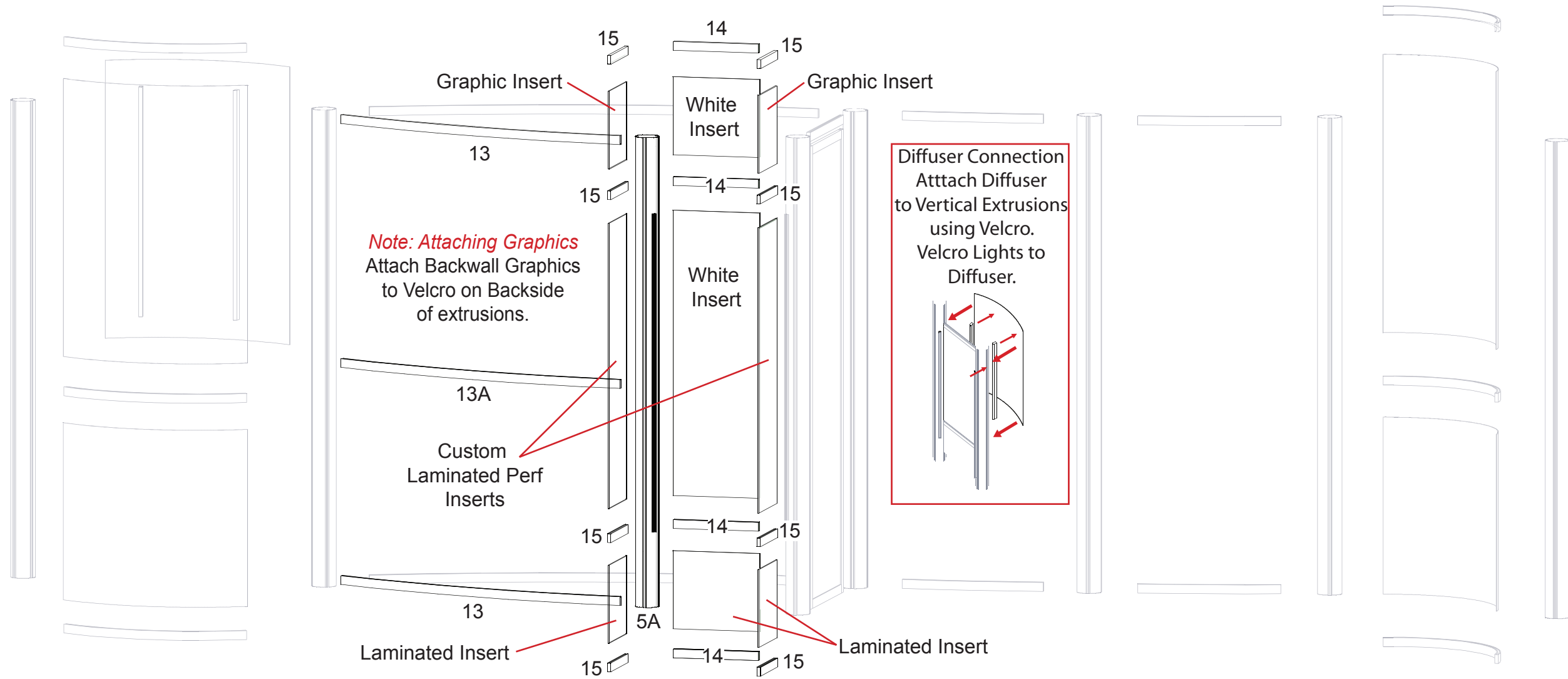

WHEN DISASSEMBLING ALUMINUM EXTRUSION, TIGHTEN ALL SETSCREWS AND LOCKS TO PREVENT LOSS DURING SHIPPING

866.652.2100

Item	Quantity	Description
5	2	96"h Vertical Extrusion w/ attached channel
14	4	15"w Horizontal Extrusion
16	2	74.6213"w Curved Extrusion
17	2	11.218"h Vertical Extrusion
18	2	94.8474"w Curved Extrusion
19	2	11.218"h Vertical Extrusion

Steps:

- 1) Connect vertical extrusions 5 to horizontal extrusions 15 (from previous page).
- 2) Connect horizontal extrusions 14 to vertical extrusions 5 placing inserts as indicated.
- 3) Connect curved horizontals 16 to vertical extrusions 17 as shown. This forms a header which then connects into vertical extrusion 5 where indicated, it hooks onto vertical extrusion 2 (from previous page) where indicated.
- 4) Connect curved horizontals 18 to vertical extrusions 19 as shown. This forms a header which then connects into vertical extrusion 5 where indicated, it hooks onto vertical extrusion 1B (from previous page) where indicated.

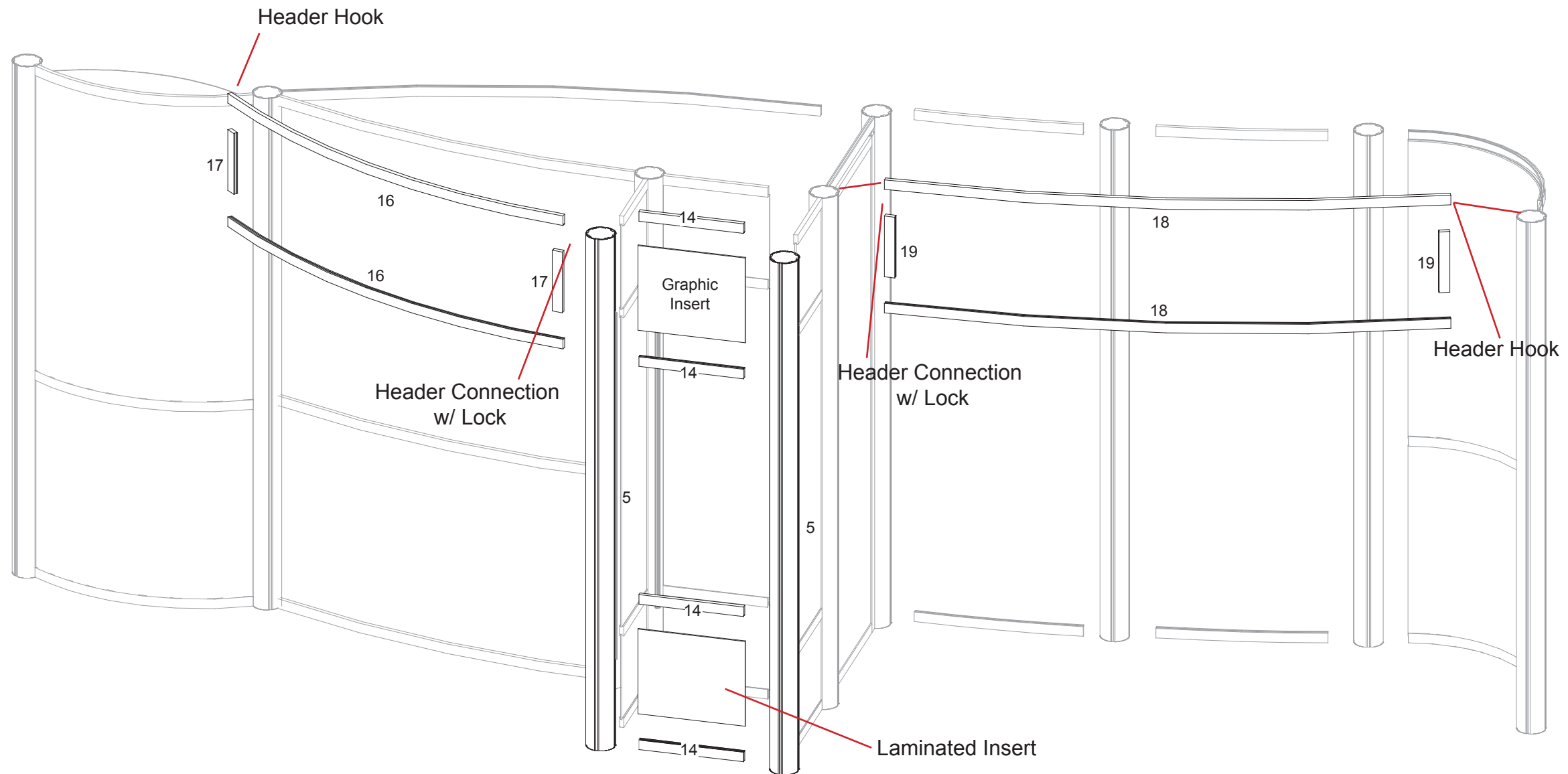

WHEN DISASSEMBLING ALUMINUM EXTRUSION, TIGHTEN ALL SETSCREWS AND LOCKS TO PREVENT LOSS DURING SHIPPING

866.652.2100

Item Number	Description
1	Curve Panel w/ Door
2	Curve Panel w/ Door

Steps:

- 1) Connector curve panels [1 and 2] together.
- 2) Place counter top atop assembled curve panels, then secure with thumbscrews to extrusion [13A].
- 3) Velcro shelf supports to backside of assembled curve panels, then set internal shelf atop supports, see internal shelf attachment detail.

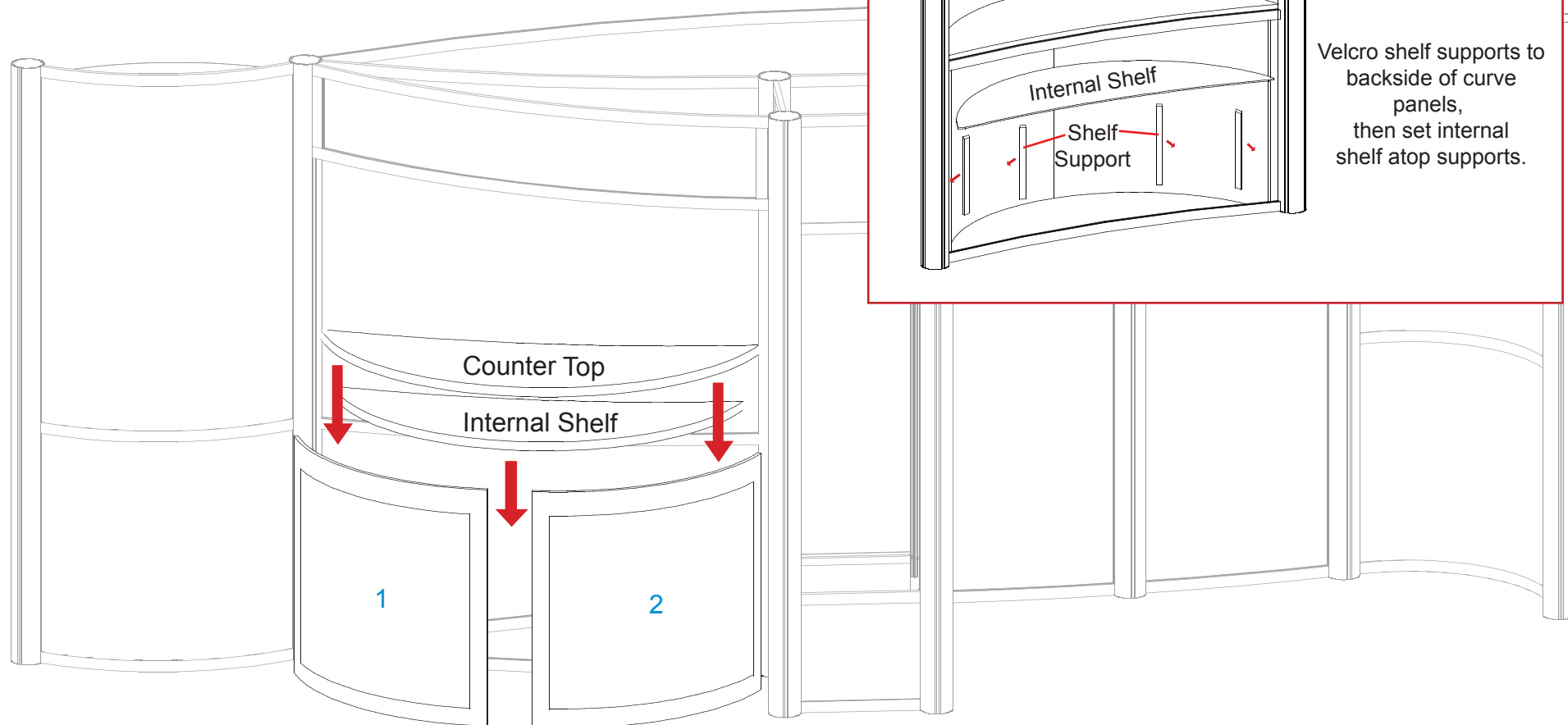

Example of Counter Top Attachment

Place Counter atop assembled curve panels and attach to curve extrusion [13A] using Thumbscrews as shown.

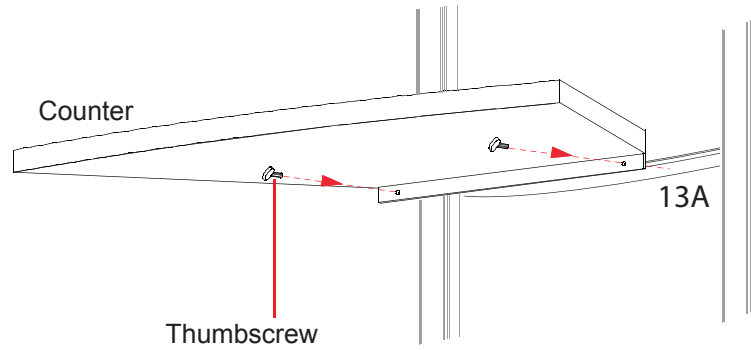

Internal Shelf Attachment

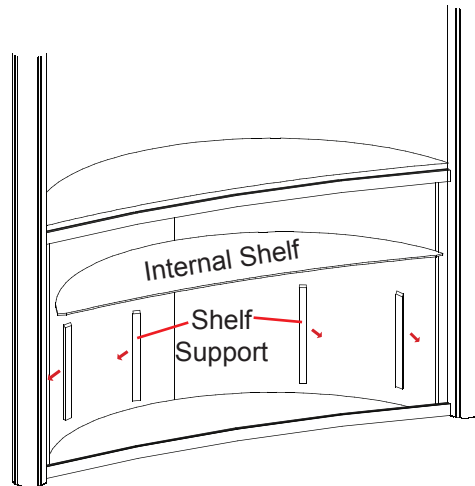

Velcro shelf supports to backside of curve panels, then set internal shelf atop supports.

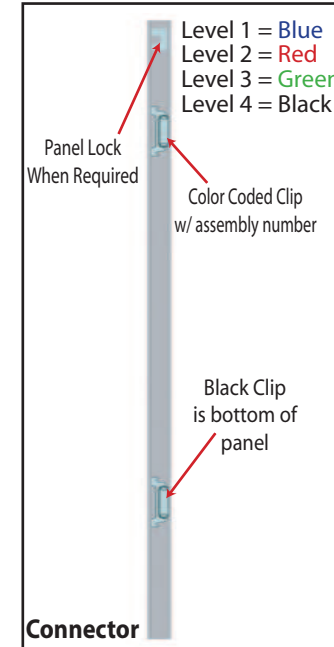

Each component has 2 clips, the lower clip is ALWAYS black. The top clip is color coded to distinguish the level. The color coded clip also contains the numbered label.

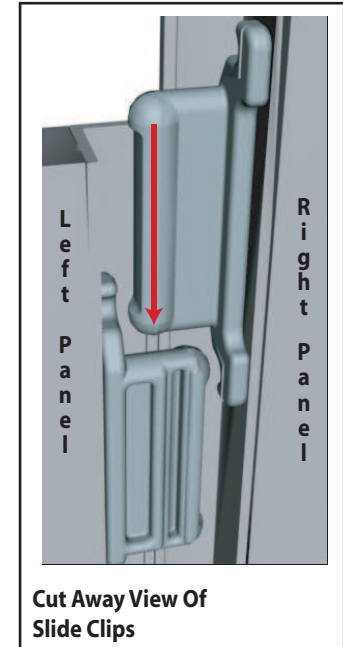

Components connect together by aligning them and sliding downward connecting clips together.

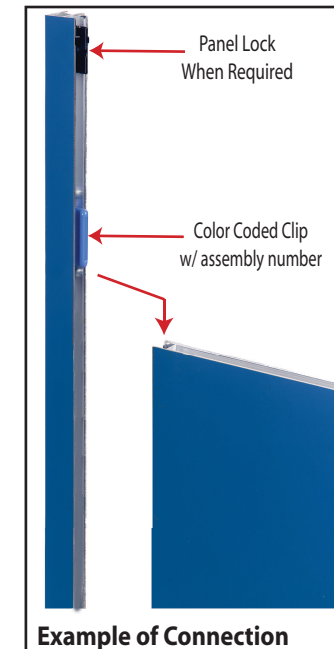

Configurations are assembled from left to right, usually starting with #1 and following the numbered sequence.

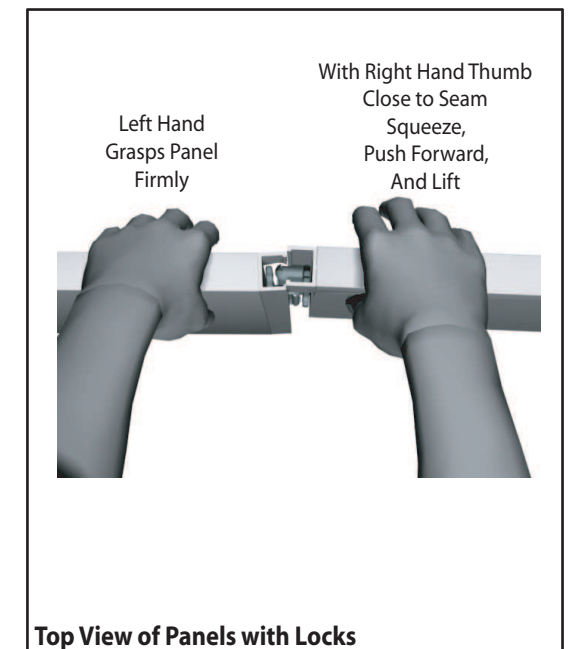

The first level of components contains panel locks that are located at the top of the panel for extra stability and a seamless connection. When disassembling panels, twist top connection slightly and lift right panel upward.

WHEN DISASSEMBLING ALUMINUM EXTRUSION, TIGHTEN ALL SETSCREWS AND LOCKS TO PREVENT LOSS DURING SHIPPING

866.652.2100

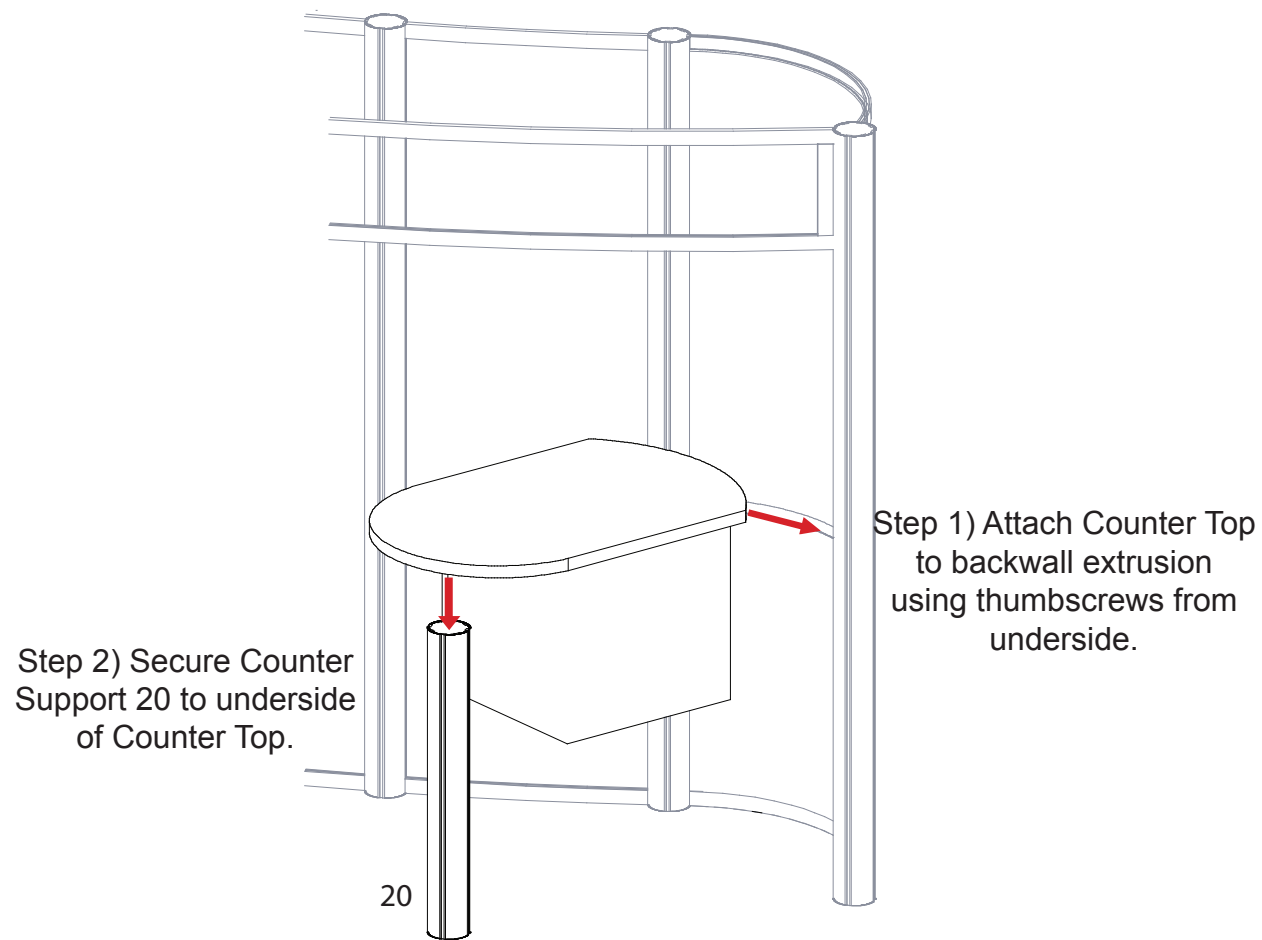
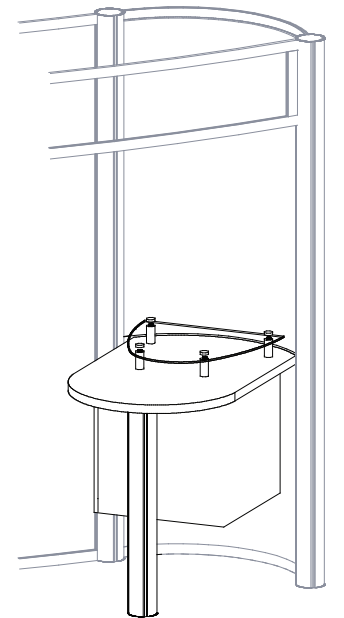

Step 2) Secure Counter Support 20 to underside of Counter Top.

Step 1) Attach Counter Top to backwall extrusion using thumbscrews from underside.

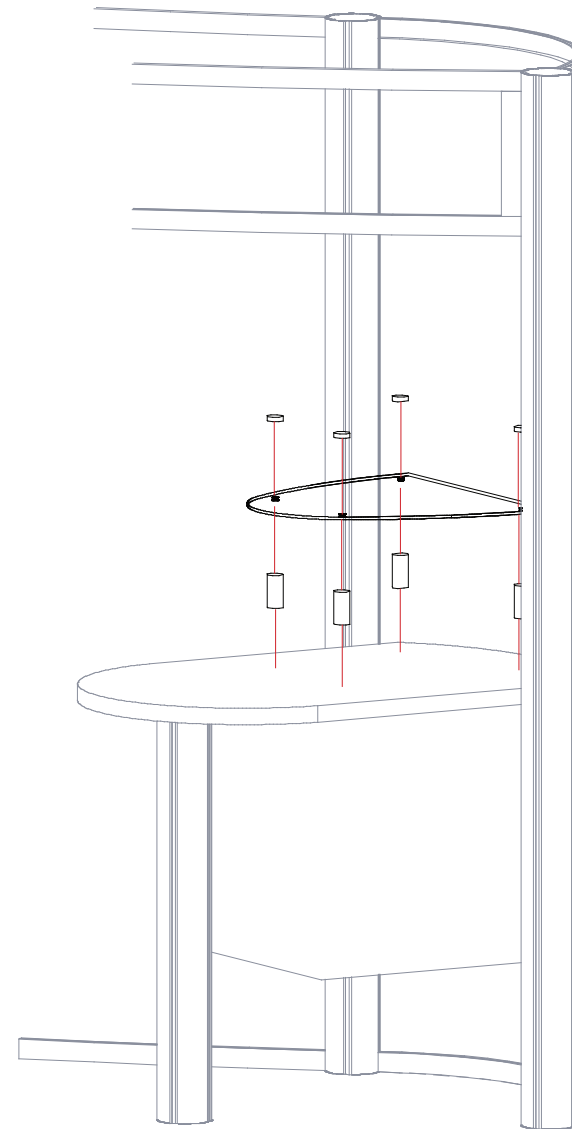

Step 3) Secure Plex Shelf to Counter Top using Standoff Barrels and Standoff Caps as shown..

WHEN DISASSEMBLING ALUMINUM EXTRUSION, TIGHTEN ALL SETSCREWS AND LOCKS TO PREVENT LOSS DURING SHIPPING

866.652.2100

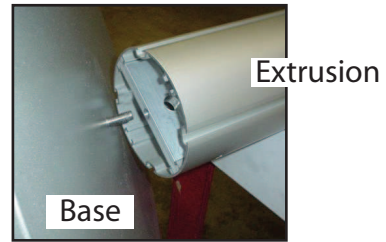

Step 1) Attach Base Plate 23 to Monitor Support 22 as shown.

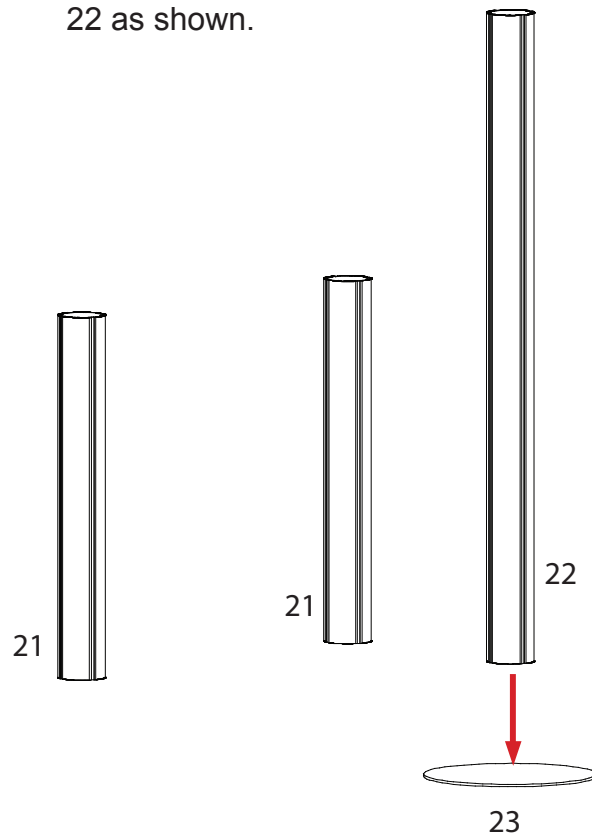

Step 2) Secure Counter Top to Counter Supports 21 and set atop pin on Monitor Support 22.

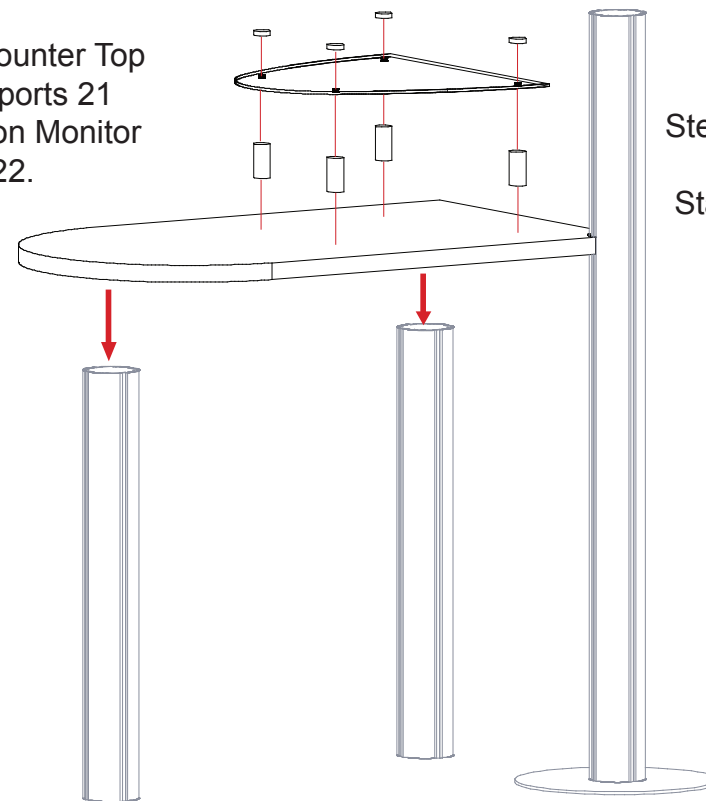

Step 3) Secure Plex Shelf to Counter Top using Standoff Barrels and Caps.

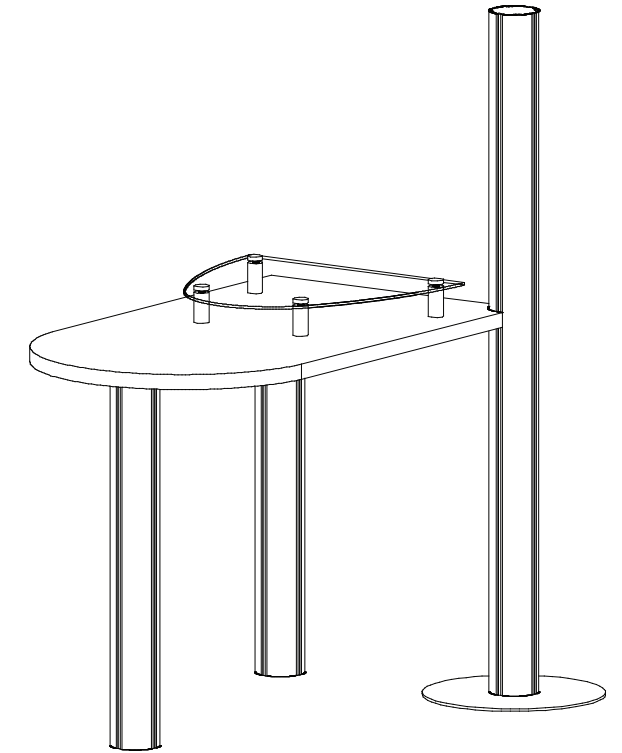

WHEN DISASSEMBLING ALUMINUM EXTRUSION, TIGHTEN ALL SETSCREWS AND LOCKS TO PREVENT LOSS DURING SHIPPING

866.652.2100

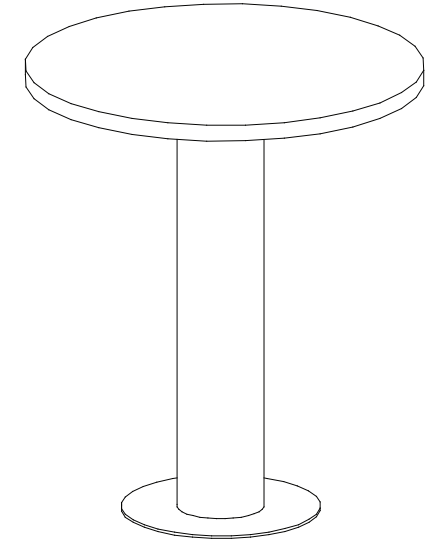

Attach Conference Table Leg 25 to Base Plate 24.
Attach counter to table leg with supplied hardware.

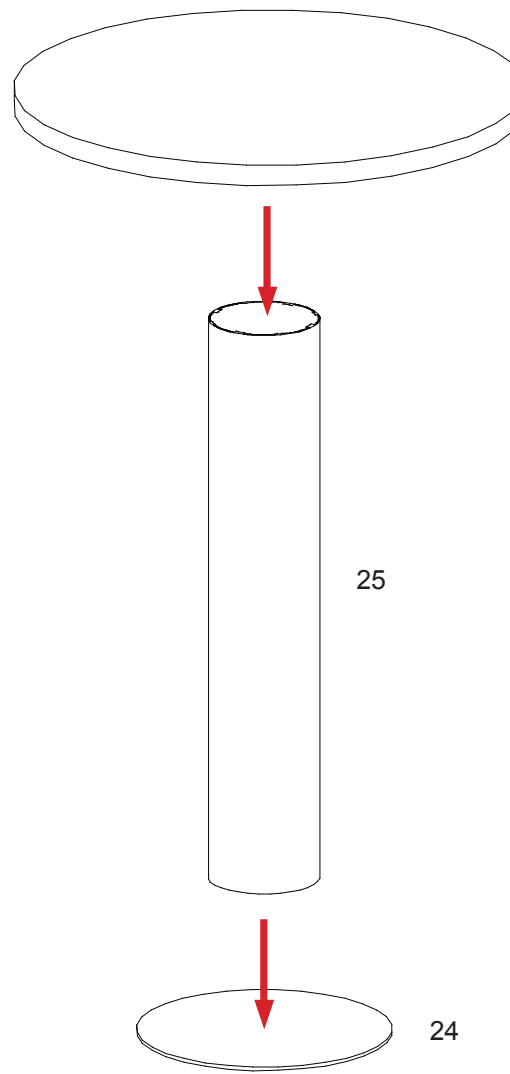

WHEN DISASSEMBLING ALUMINUM EXTRUSION, TIGHTEN ALL SETSCREWS AND LOCKS TO PREVENT LOSS DURING SHIPPING