

euro It | HYBRIDS

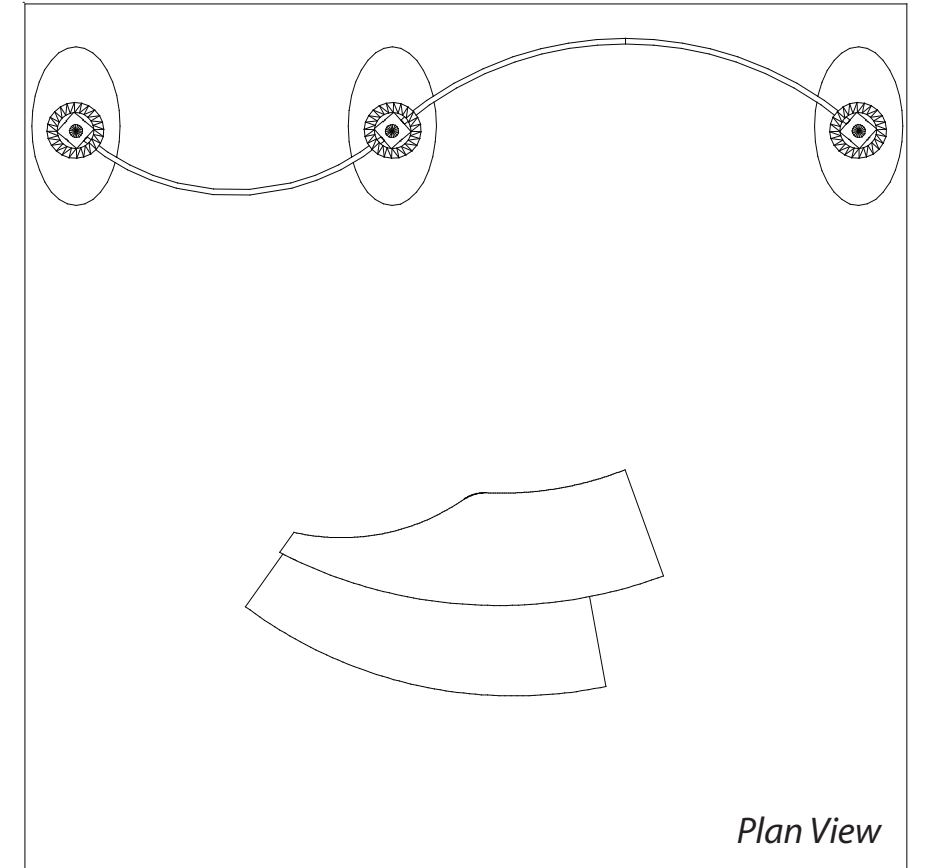
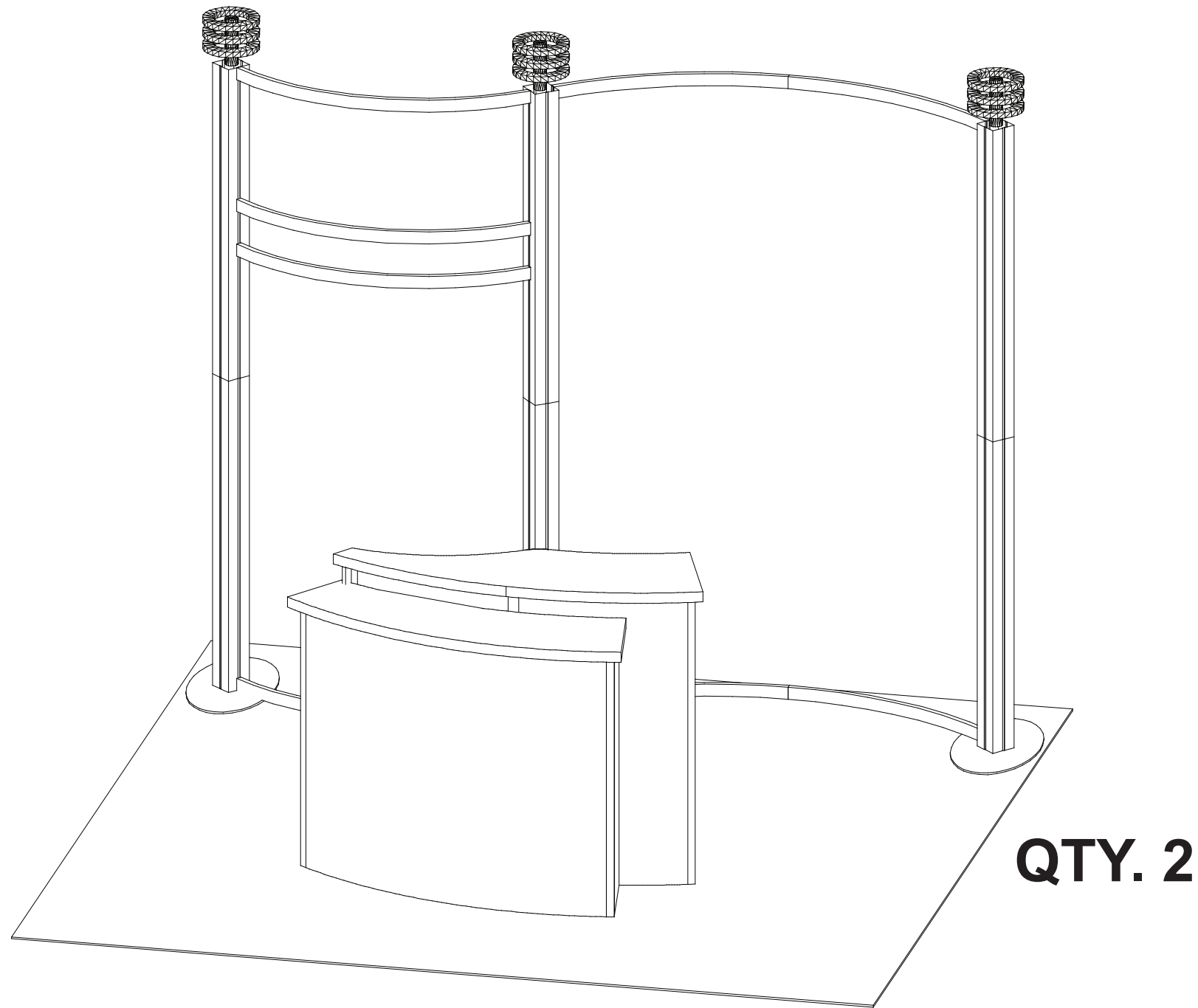

WHEN DISASSEMBLING ALUMINUM EXTRUSION, TIGHTEN ALL SETSCREWS AND LOCKS TO PREVENT LOSS DURING SHIPPING

euro lt | HYBRIDS

Using Your Setup Instructions

The Euro LT Hybrids Setup Instructions are created specifically for your configuration. They are laid out sequentially in levels, including exploded views, and a logical series of detailed steps to assemble the main structure and components. We encourage you to study the instructions **before** attempting to assemble your exhibit.

Each page reminds you to tighten the setscrews after disassembling your exhibit to prevent loss of the locks and setscrews (see below in RED). This is VERY IMPORTANT.

Cleaning and Packing Your Display

- 1) Use care when cleaning aluminum extrusion or acrylic inserts. Use only non-abrasive cleaners.
- 2) When cleaning laminate inserts, countertops, or panels use mild cleansers and a soft material such as cotton.
- 3) Keep all display components away from extreme heat and long exposure to sunlight to avoid warping and fading.
- 4) Retain all packing material. It will make re-packing much easier and will reduce the likelihood of shipping damage.

General Setup Instructions for Extrusion System



Most exhibits can be assembled with the supplied Hex Key Tool. Occasionally, a flat head screwdriver may be required.

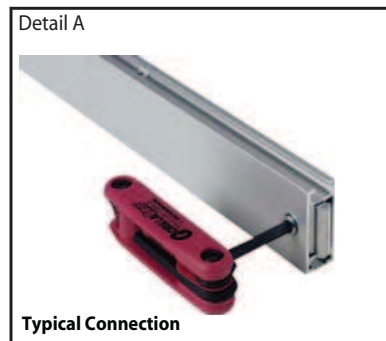

Most horizontal extrusion connections have a patented expandable lock. This lock inserts into the groove of an opposing extrusion. Tightening the lock with the Hex Key Tool expands the lock and creates a strong positive connection.

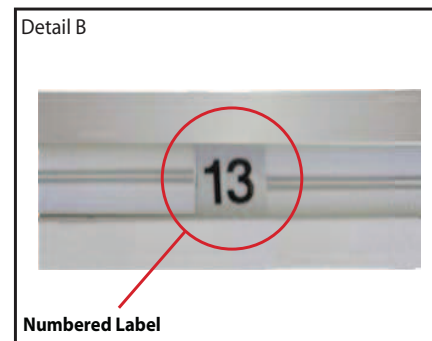

Each extrusion contains a numbered label which corresponds with setup instructions. The label is located within a groove of the extrusion (when possible). With extrusion components the labels contain Black numbers unless otherwise specified.



Remove only (1) setscrew when disassembling. Replace setscrew in extrusion after assembling it. Before packing, replace setscrew in extrusion to avoid losing it.

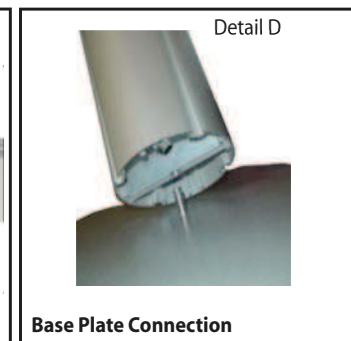

Attach base plate to round or square vertical extrusion using the bolt provided. Be careful not to strip the threads.

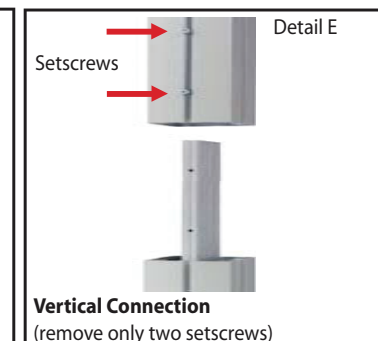

When vertical extrusions are packed in portable cases rather than crates or tubs, they must be broken down into smaller section which then require assembly.

Remove only (2) setscrews when disassembling. Replace setscrews in extrusion after assembling it. Before packing, replace setscrews in extrusion to avoid losing them.

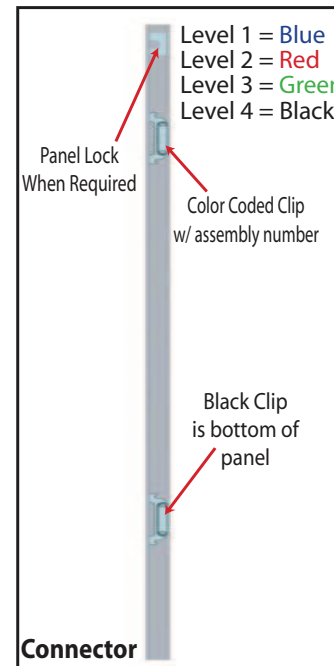

Each component has 2 clips, the lower clip is ALWAYS black. The top clip is color coded to distinguish which level. The color coded clip also contains the numbered label.

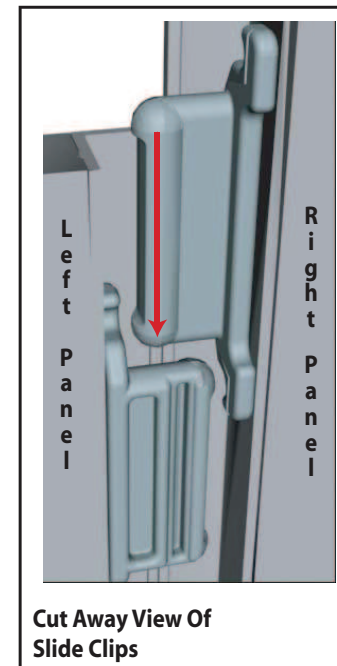

Components connect together by aligning them and sliding downward connecting clips together.

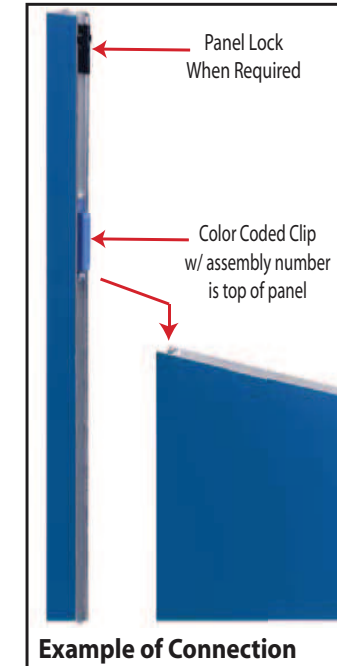

Configurations are assembled from left to right, usually starting with #1 and following the numbered sequence.

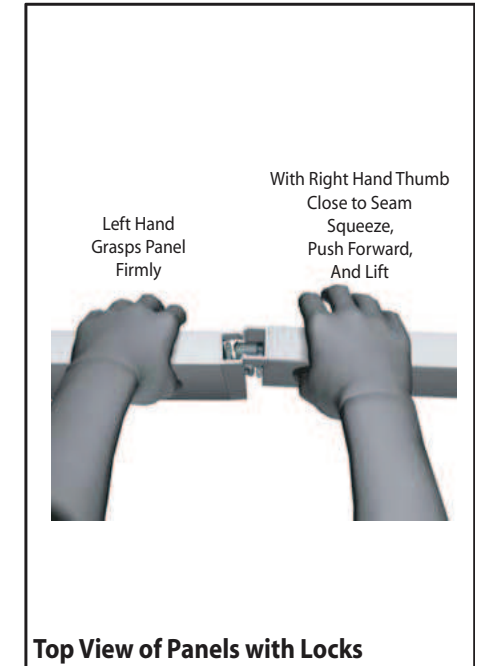

The first level of components contain panel locks that are located at the top of the panel for extra stability and seamless connection. When disassembling panels twist top connection slightly and lift right panel upward.

WHEN DISASSEMBLING ALUMINUM EXTRUSION, TIGHTEN ALL SETSCREWS AND LOCKS TO PREVENT LOSS DURING SHIPPING

866.652.2100

Item	Qty.	Description
35	3	Base Plate
36	3	46" h Lower Vertical Extrusion
37	3	46" h Upper Vertical Extrusion
38	1	44.0229" w Formed Horizontal Extrusion w/ Velcro Attached to Bottom Back of Extrusion
39	2	44.0229" w Formed Horizontal Extrusion
40	1	44.0229" w Formed Horizontal Extrusion
41a/41b	1/1	33" w Curved Horizontal Extrusion w/ Velcro Attached to Bottom Back of Extrusion
42a/42b	1/1	33" w Curved Horizontal Extrusion w/ Velcro Attached to Top Back of Extrusion

Steps:

- 1) Attach vertical extrusions [36] to base plates [35], see detail on general info page.
- 2) Attach upper vertical extrusions [37] atop lower vertical extrusions [36] as shown.
- 3) Connect horizontal extrusions [41a to 41b and 42a to 42b] together.
- 4) Attach horizontal extrusions [38, 39 and 40] and horizontal assemblies [41a/41b and 42a/42b] between vertical assemblies.
- 5) Attach monitor mount plate to horizontal extrusions [39] as shown, then attach monitor mount to plate.
- 6) Apply graphics to back of assembled backwall.

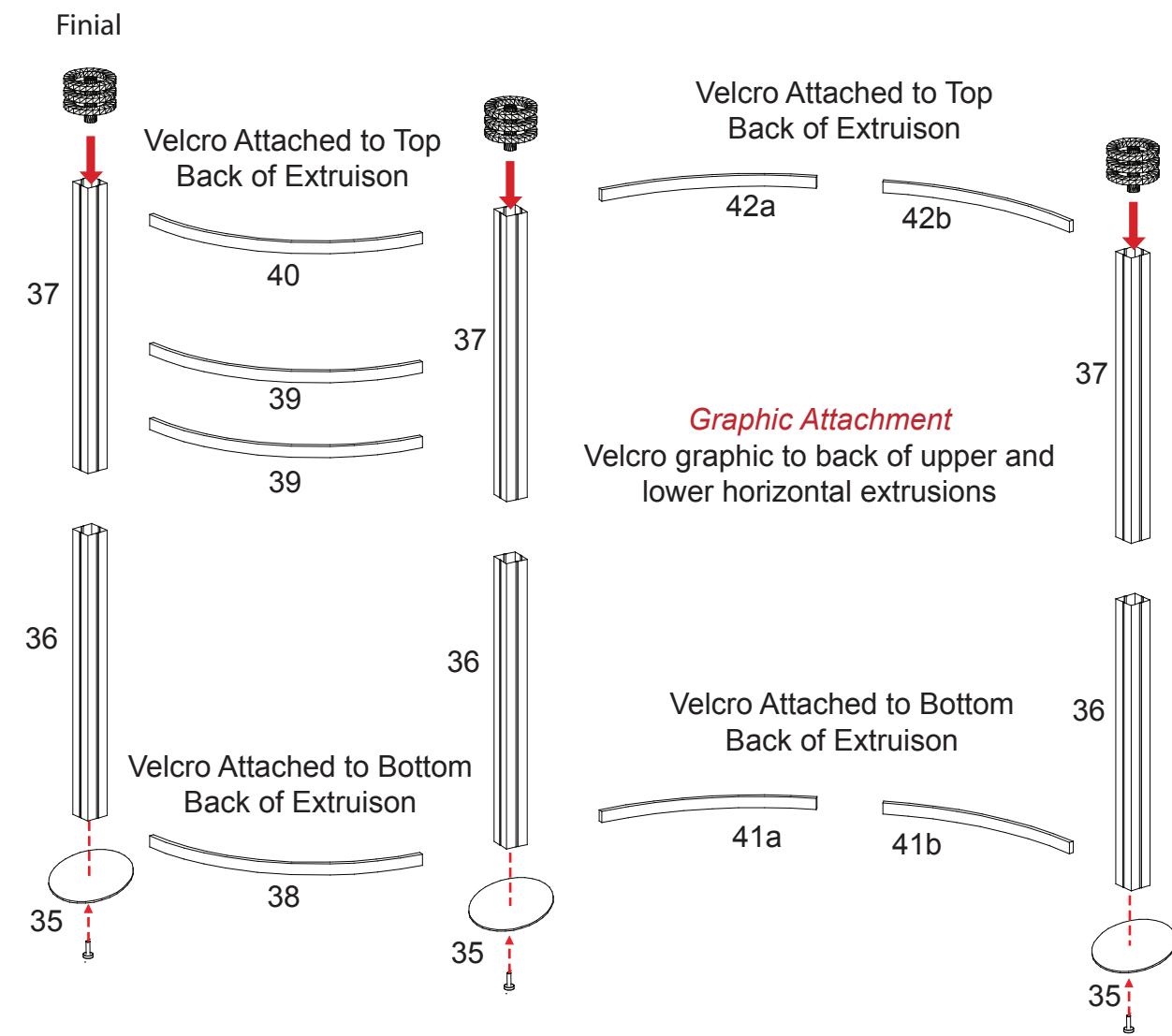
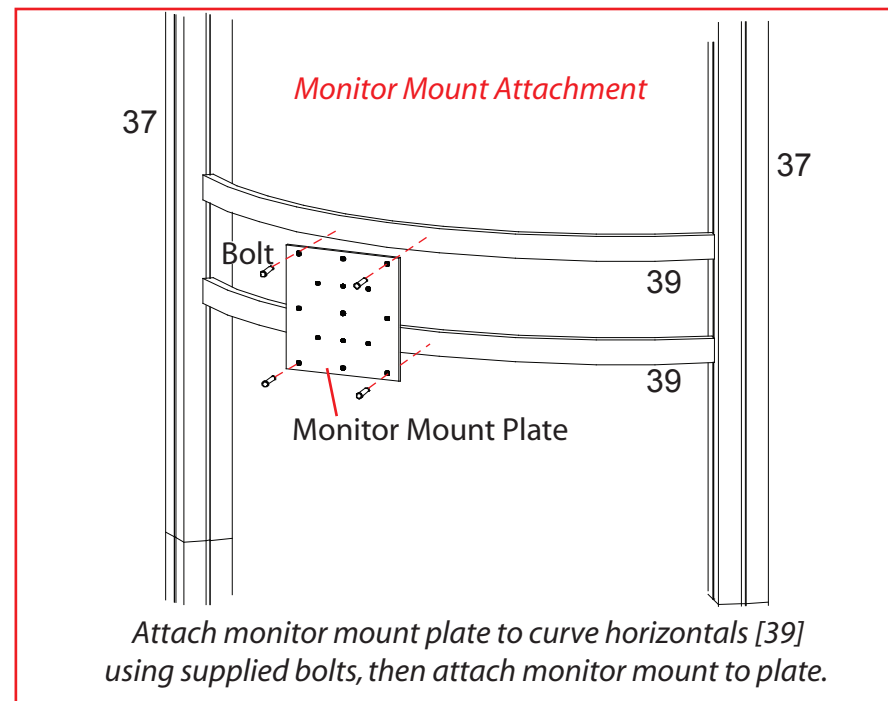
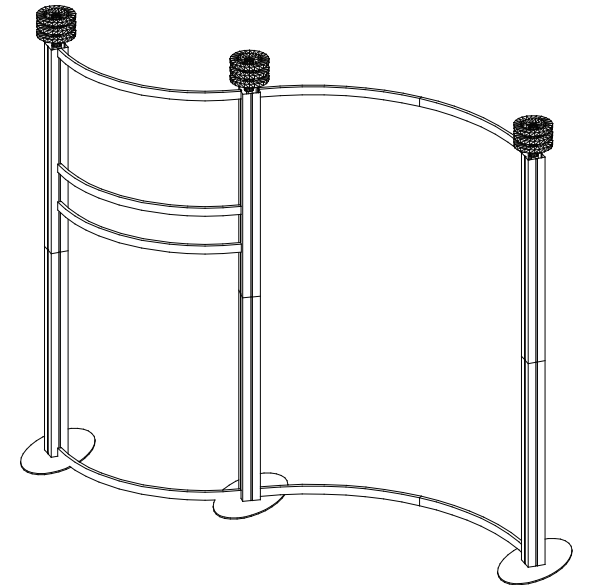

WHEN DISASSEMBLING ALUMINUM EXTRUSION, TIGHTEN ALL SETSCREWS AND LOCKS TO PREVENT LOSS DURING SHIPPING

866.652.2100

Item Number	Description
1	11.5"w x 42"h Flat Panel
2	42"h 90° Connector
3	46"r x 42"h Door Panel
4	42"h 90° Connector
5	11.5"w x 42"h Flat Panel
6	42"h 90° Connector
7	57.5"r x 42"h Curve Panel
8	42"h T Connector
9	57.5"r x 42"h Curve Panel
10	42"h Flex Connector
11	6.5"w x 38"h Flat Panel
12	38"h Flex Connector
13	57.5"r x 38"h Curve Panel
14	38"h 90° Connector
15	11.5"w x 38"h Flat Panel

- Steps:
- 1) Assemble by starting at panel #1* and continue in numerical order.
 - 2) Velcro shelf supports inside assembled base, then set internal shelf atop supports.
 - 3) Place counters atop assembled pedestal.

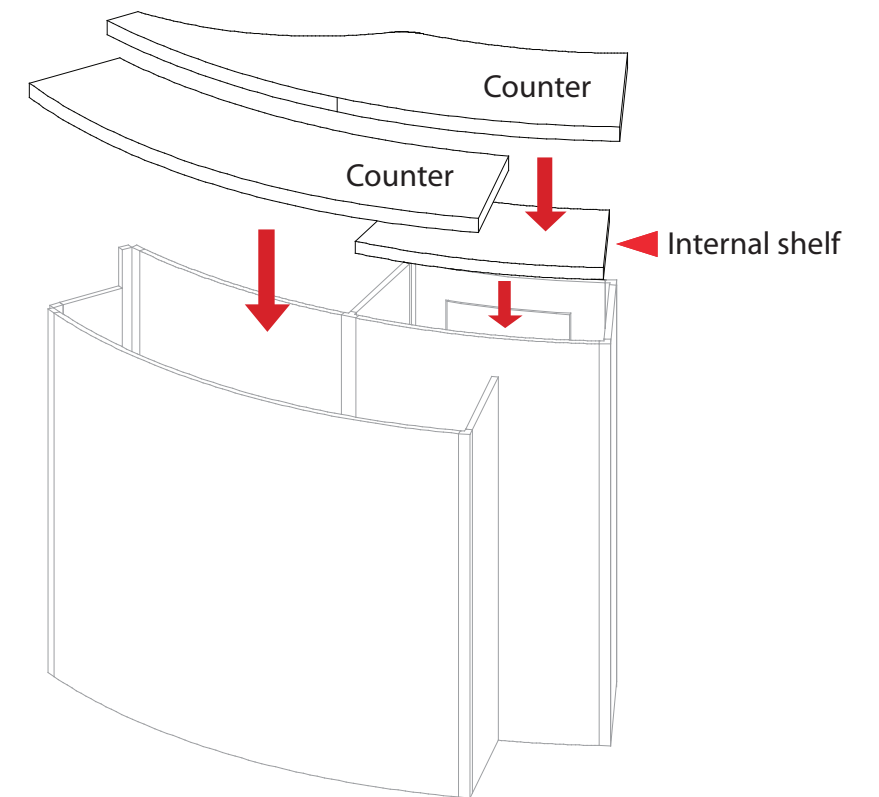
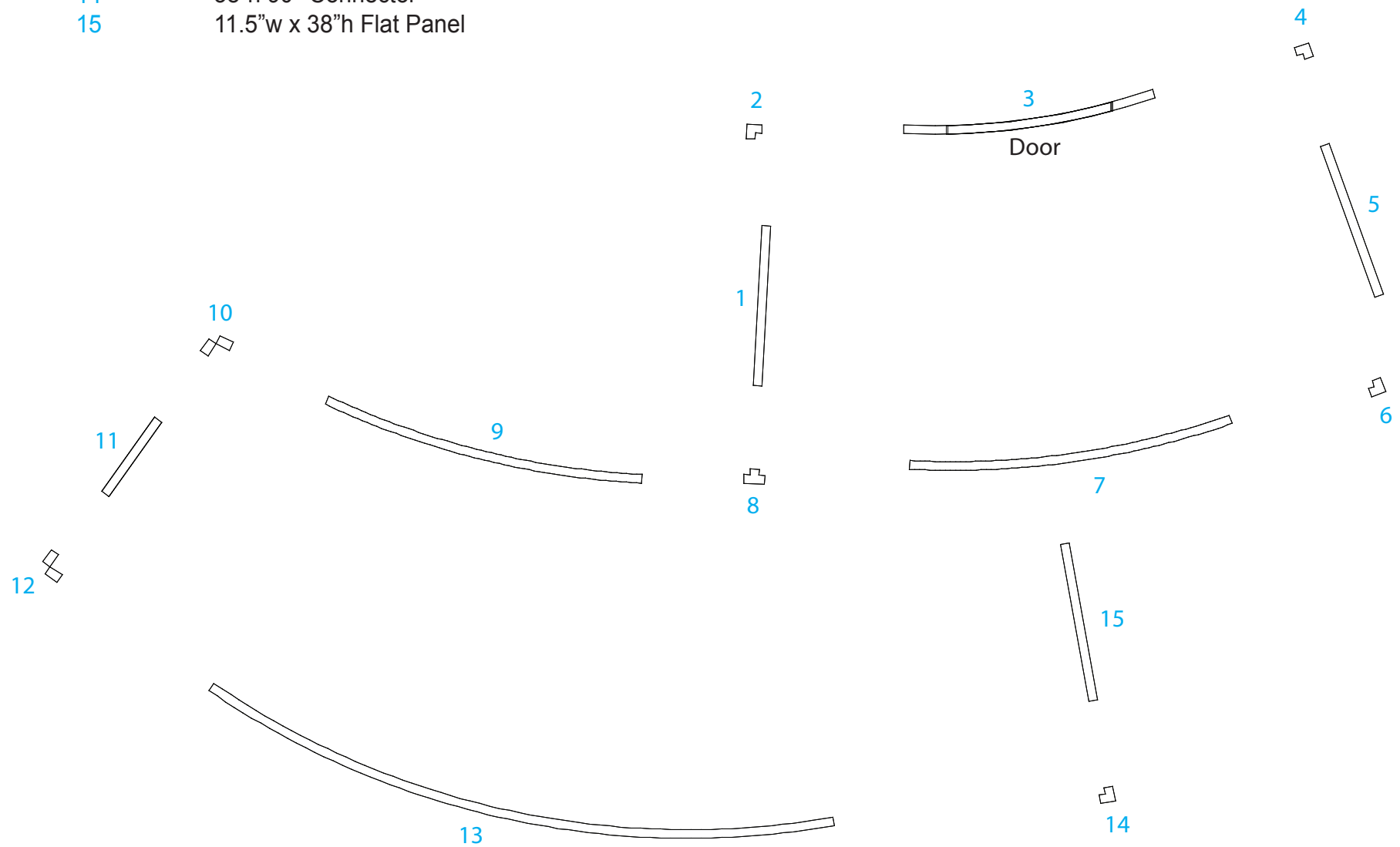
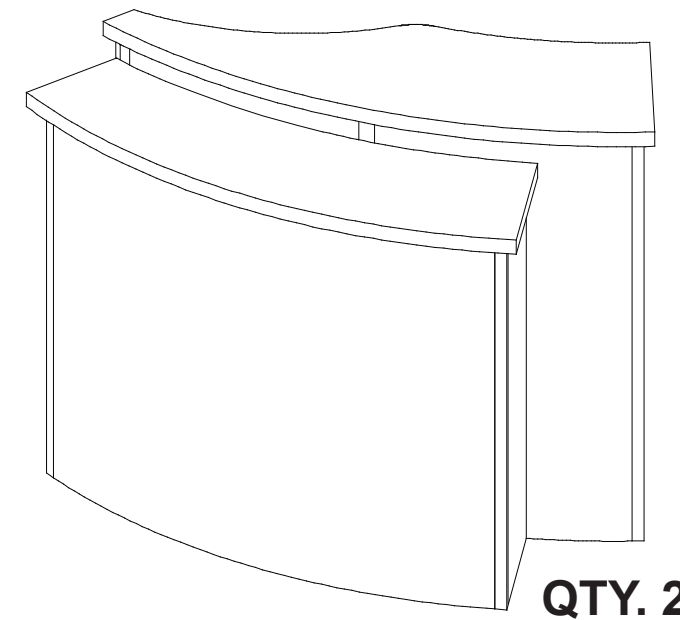

WHEN DISASSEMBLING ALUMINUM EXTRUSION, TIGHTEN ALL SETSCREWS AND LOCKS TO PREVENT LOSS DURING SHIPPING

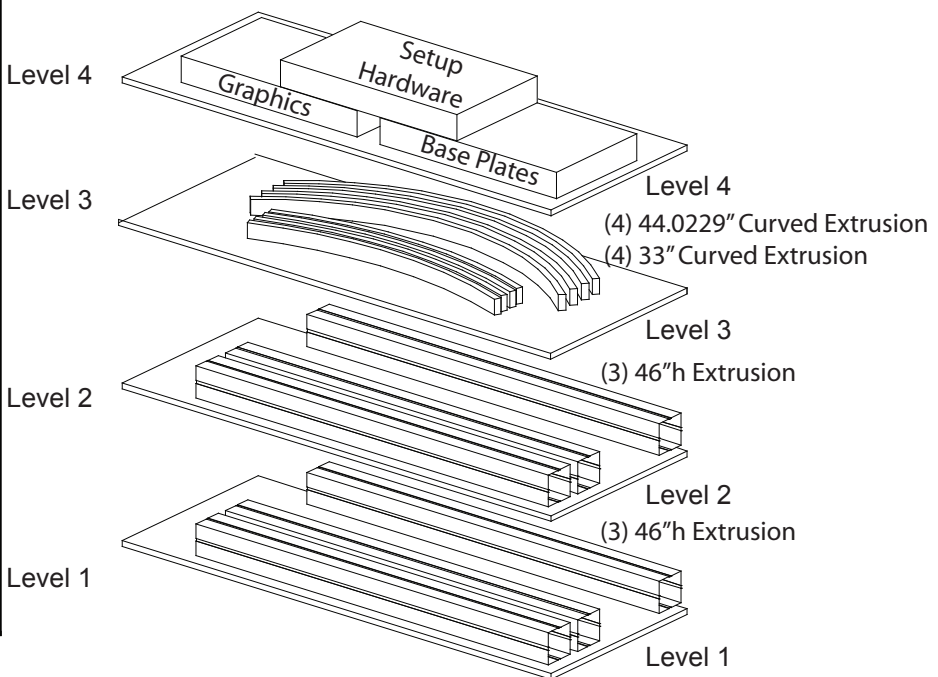
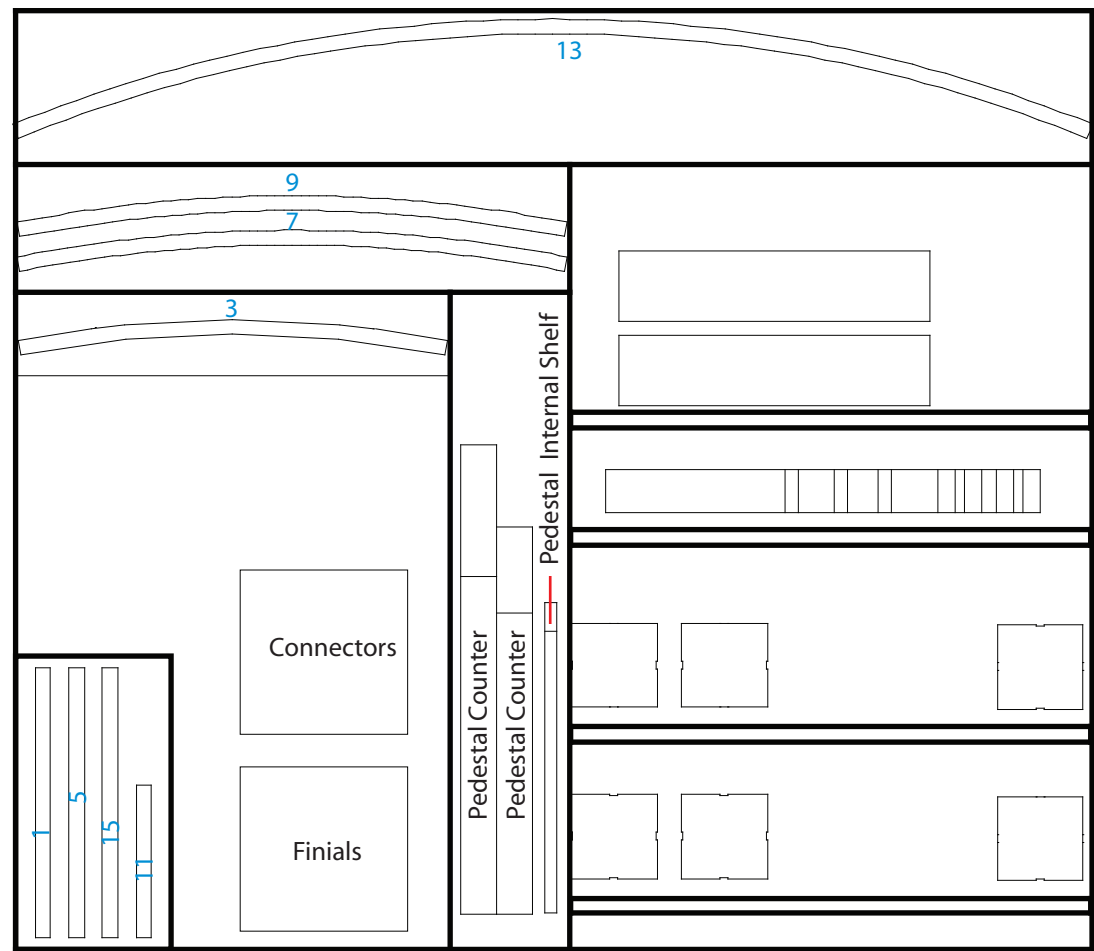

WHEN DISASSEMBLING ALUMINUM EXTRUSION, TIGHTEN ALL SETSCREWS AND LOCKS TO PREVENT LOSS DURING SHIPPING

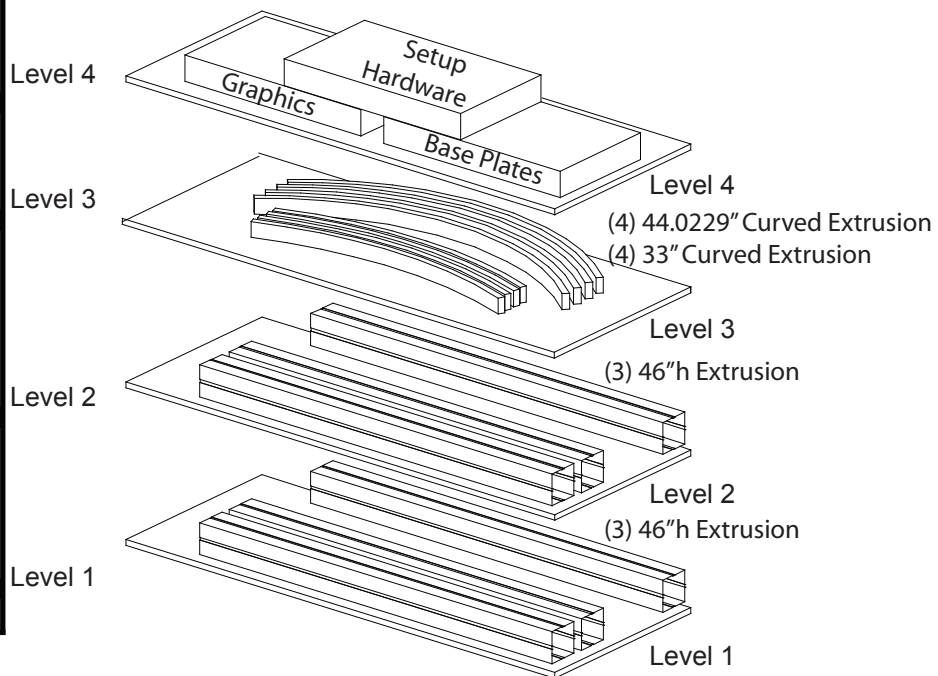
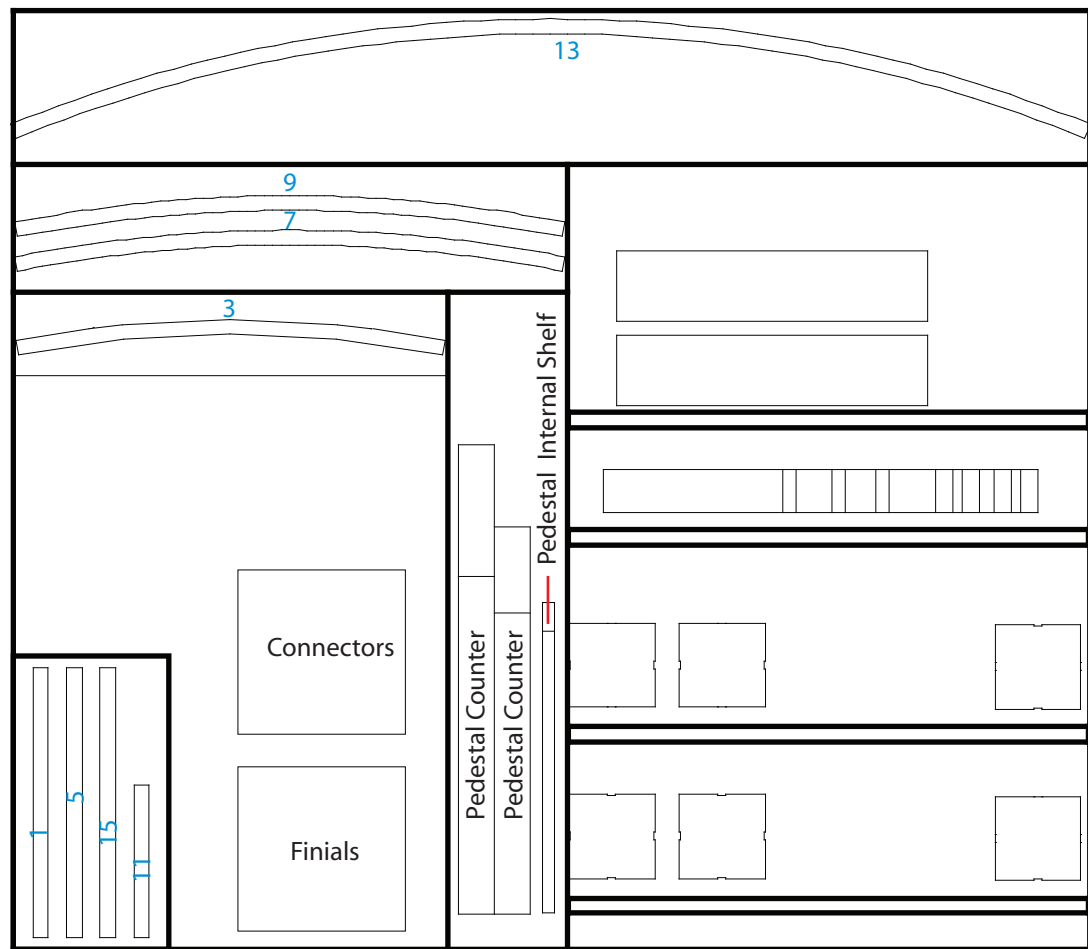

Pedestal Rollable Graphic



Crate Front View

WHEN DISASSEMBLING ALUMINUM EXTRUSION, TIGHTEN ALL SETSCREWS AND LOCKS TO PREVENT LOSS DURING SHIPPING