

Perfect 10 Hybrid Displays

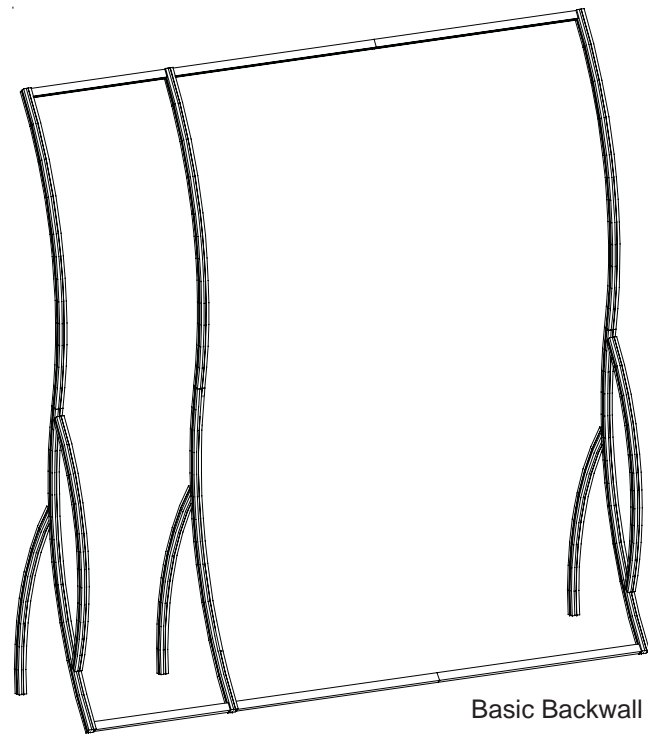

Basic Backwall Frame Only



WHEN DISASSEMBLING ALUMINUM EXTRUSION, TIGHTEN ALL SETSCREWS AND LOCKS TO PREVENT LOSS DURING SHIPPING

866.652.2100

Part Number	Qty for Step	Description
1	1	Left Leg Assembly
2	1	Middle Leg Assembly
3	1	Right Leg Assembly
4	3	Upper Curved Vertical
5	2	23" w Horizontal
6	2	69" w Horizontal

Steps:

NOTE: Assembly may be easiest if assembled face down on floor then lifted upright.

- 1) Connect vertical extrusions [4] to leg assemblies [1 - 3] as shown.
- 2) Connect horizontal extrusions [5, 6 and 7] between vertical assemblies by slightly tightening BLACK knobs on backside of extrusion as shown.

NOTE: Make sure Velcro faces toward back and knobs face horizontally as shown in detail.

**** Various Accessories Available ****

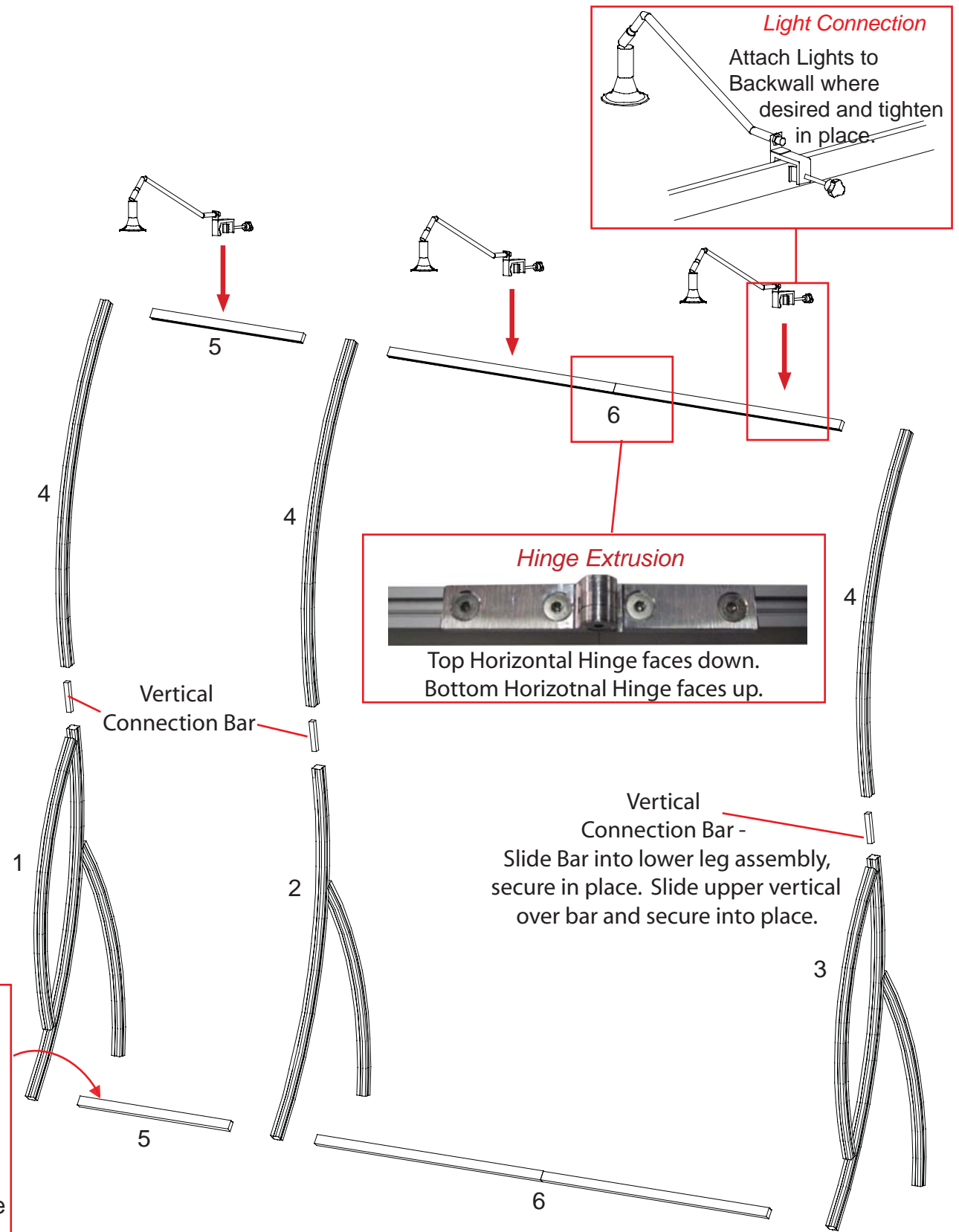
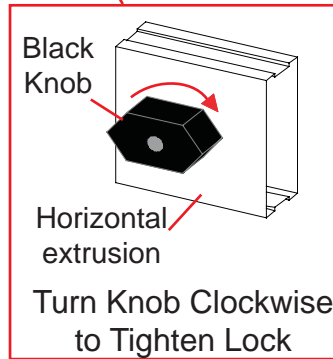
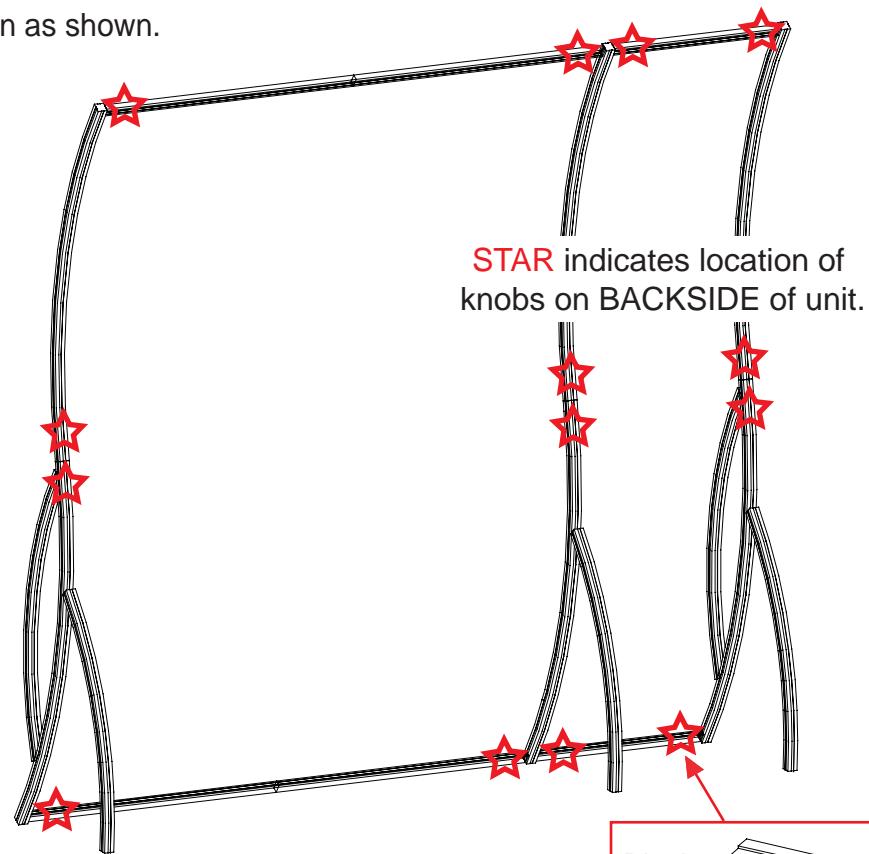
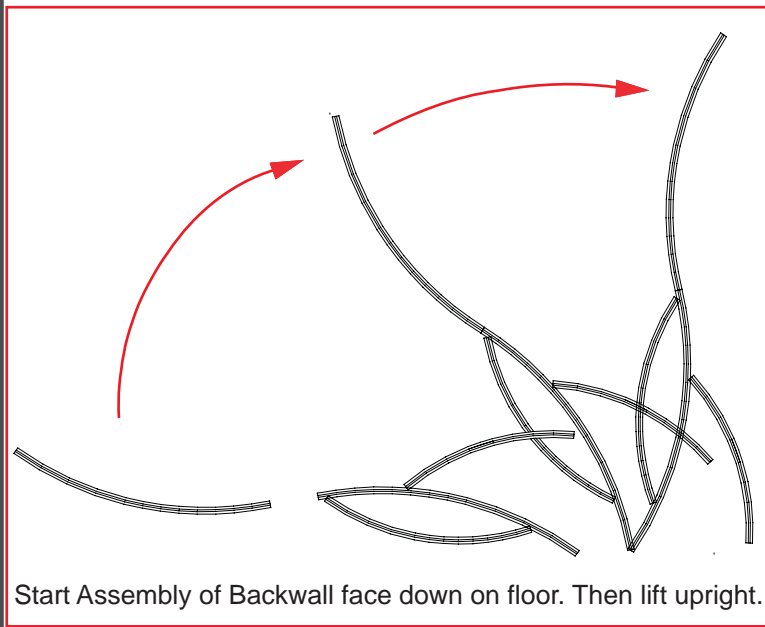

WHEN DISASSEMBLING ALUMINUM EXTRUSION, TIGHTEN ALL SETSCREWS AND LOCKS TO PREVENT LOSS DURING SHIPPING

Accessory Attachment - Attach Header support then slide header into groove of extrusion.

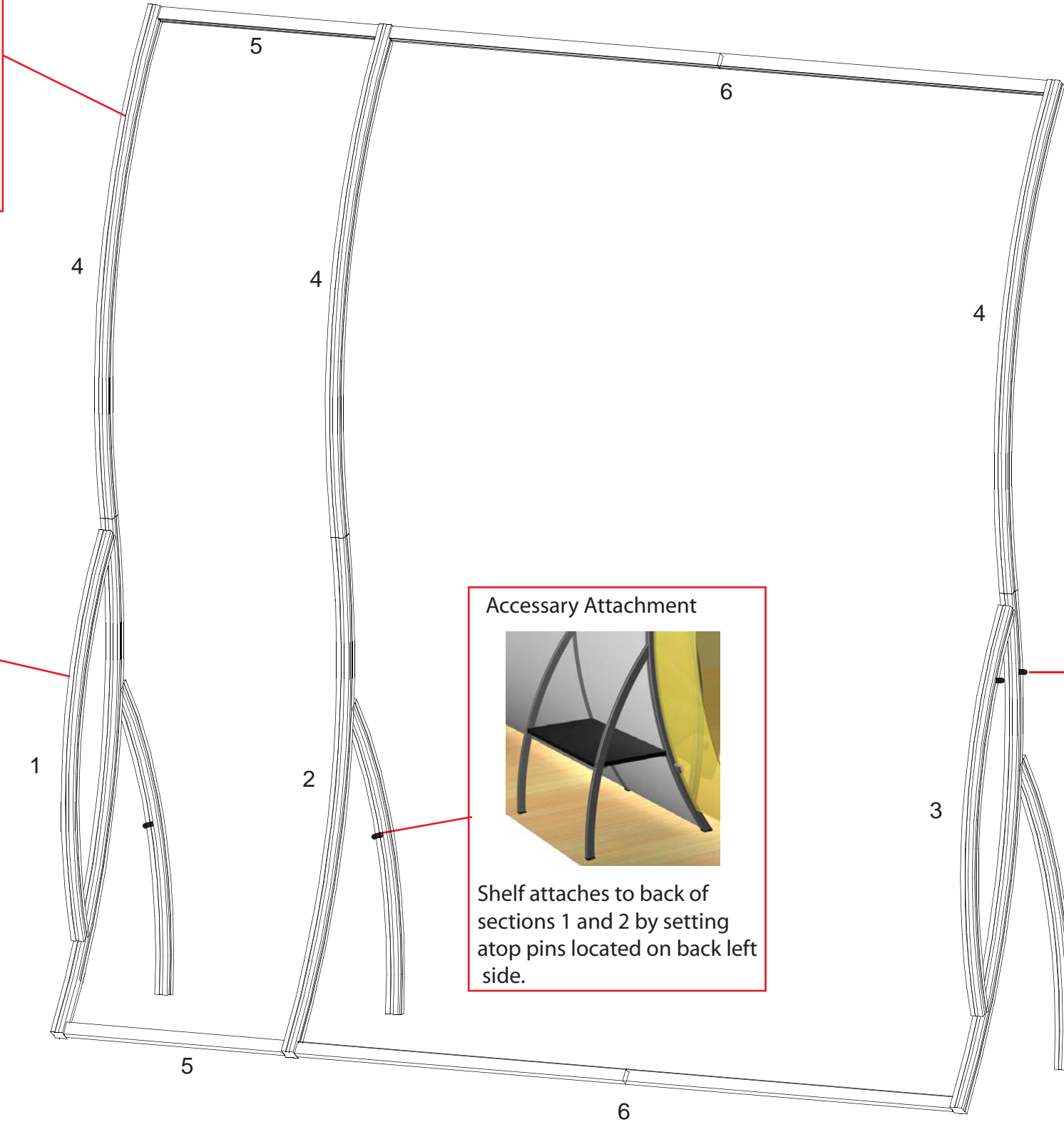
Accessory Attachment



Shelf attaches to section 3 by setting atop pins located on right side and securing into place with thumbscrew on left.

Accessory Attachment



Shelf attaches to back of sections 1 and 2 by setting atop pins located on back left side.



When attaching counter you will need to first slide shelf onto back pin then set down on front pin.

Decorative Blade Attachment

Slide A10 Clamp into groove of square extrusion.

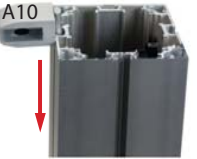

When desired location is found, tighten set screw to secure.



Attach decorative wing and blade by attaching A10's then wing.



Tighten black plastic set screw to secure Wing in place.



WHEN DISASSEMBLING ALUMINUM EXTRUSION, TIGHTEN ALL SETSCREWS AND LOCKS TO PREVENT LOSS DURING SHIPPING

866.652.2100

Part Number	Qty for Step	Description
A	1	Left Leg Assembly
B	1	Right Leg Assembly
C	3	Horizontal Extrusion
D	1	Horizontal Extrusion w/ Door Stopper

Steps:

NOTE: Assembly may be easiest if assembled face down on floor then lifted upright.

- 1) Connect lower horizontal extrusions [C] between leg assemblies [A and B] as shown.
- 2) Insert laminated infill into grooves of leg extrusions and set atop lower horizontal extrusion [C].
- 3) Attach upper horizontal extrusion w/ door stopper [D] between leg assemblies [A and B], and set flush with top of legs [A and B].
- 4) Attach extrusion door between leg assemblies [A and B] and atop laminated infill.
- 5) Attach lower horizontal extrusions [C] between leg assemblies [A and B] as shown.
- 6) Insert laminated infill into grooves of leg extrusions and set atop lower horizontal extrusion [C].
- 7) Attach upper horizontal extrusion [C] between leg assemblies [A and B] and atop laminated infill as shown.

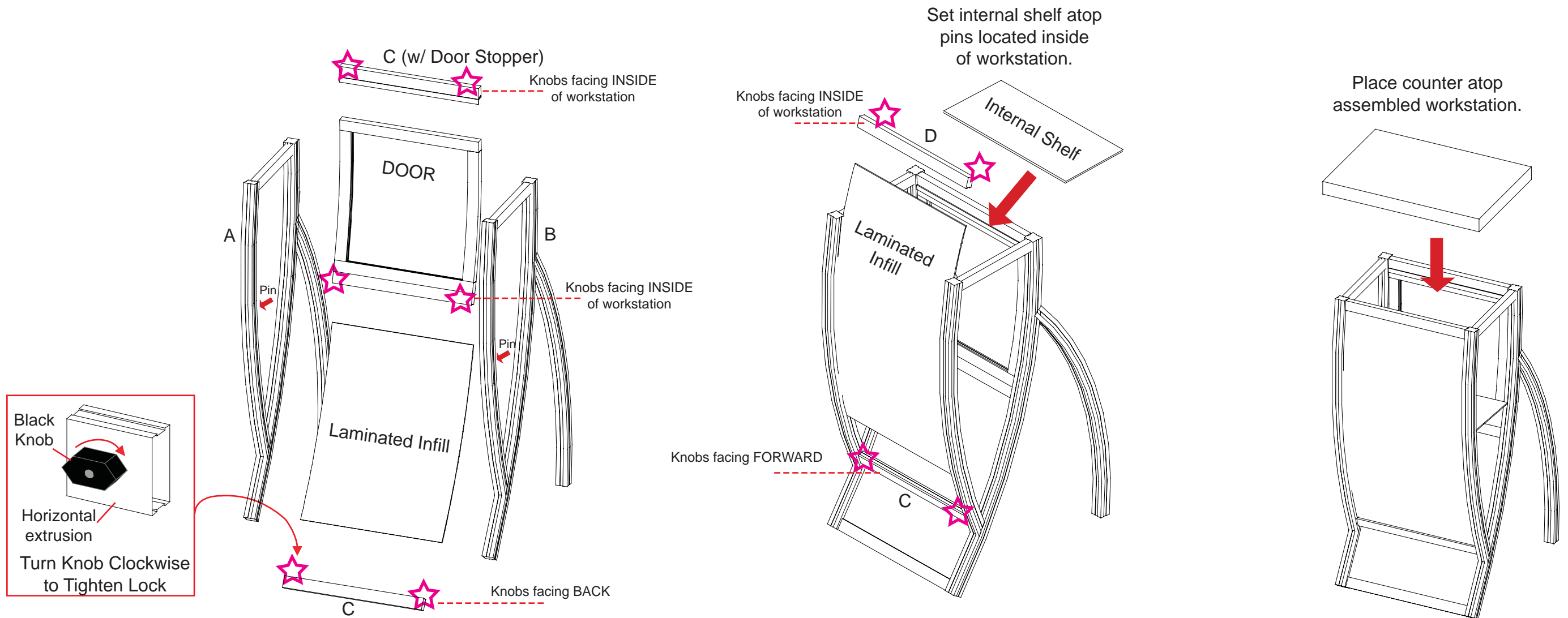
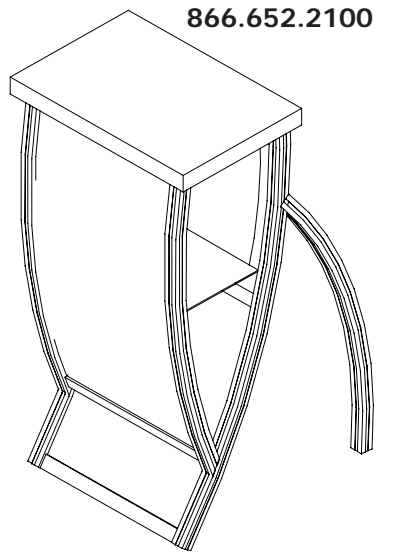

WHEN DISASSEMBLING ALUMINUM EXTRUSION, TIGHTEN ALL SETSCREWS AND LOCKS TO PREVENT LOSS DURING SHIPPING