

euro It | *HYBRIDS*

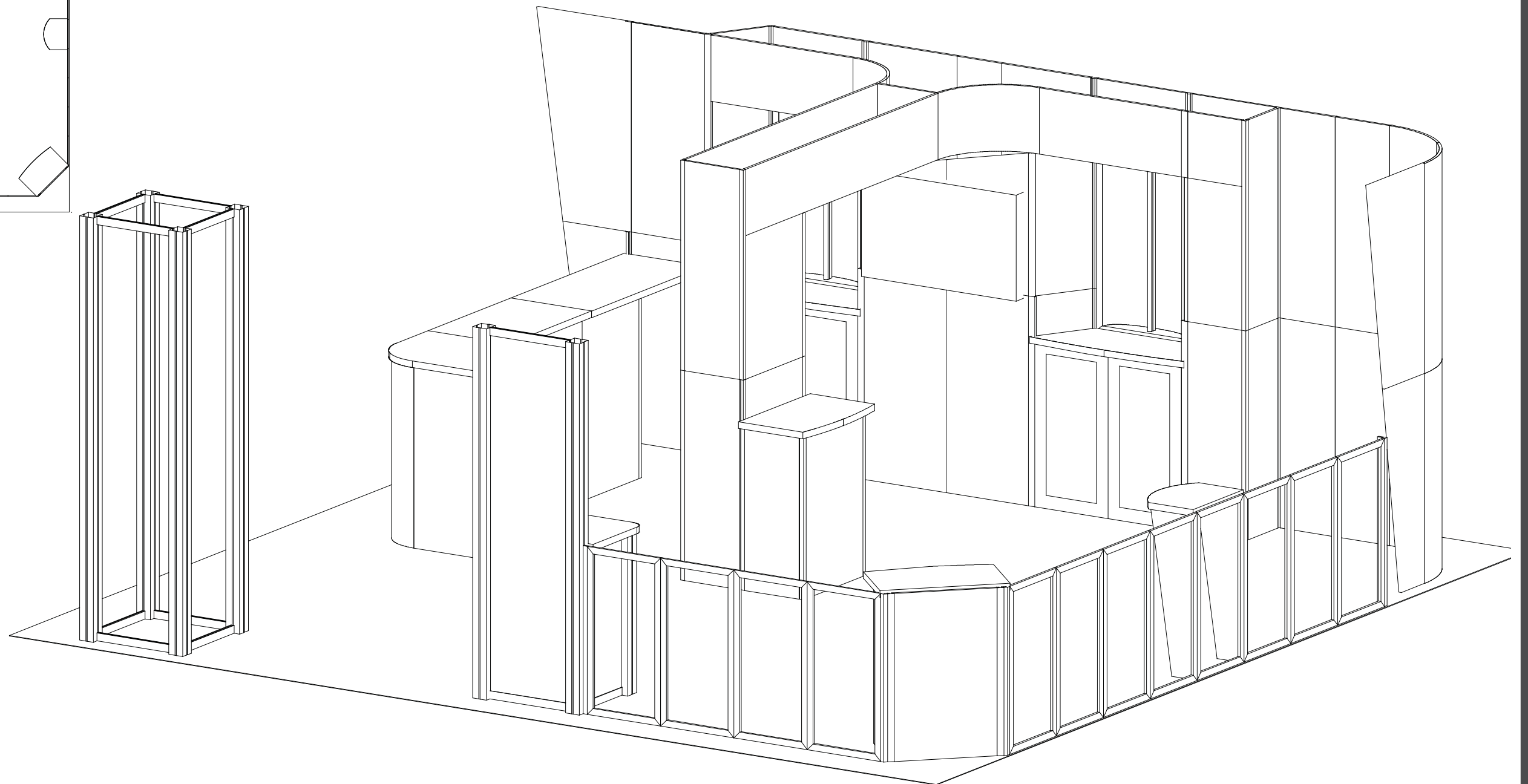
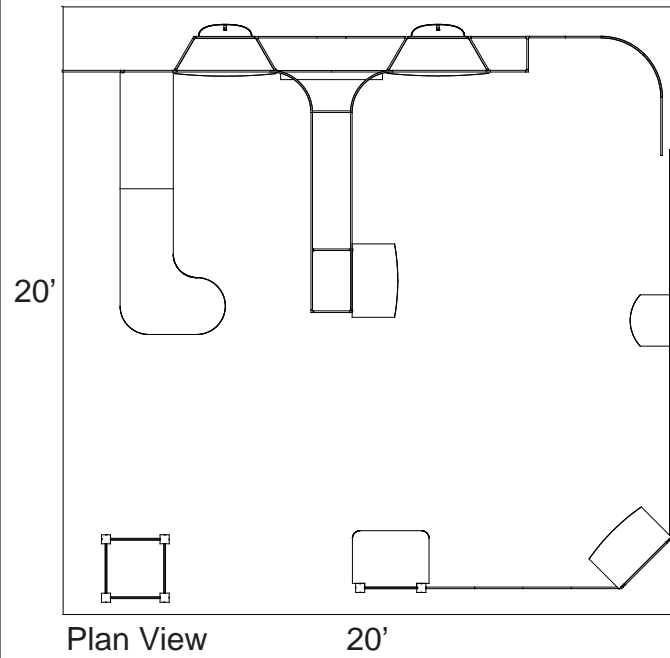

WHEN DISASSEMBLING ALUMINUM EXTRUSION, TIGHTEN ALL SETSCREWS AND LOCKS TO PREVENT LOSS DURING SHIPPING

euro lt | HYBRIDS

Using Your Setup Instructions

The Euro LT Hybrids Setup Instructions are created specifically for your configuration. They are laid out sequentially in levels, including exploded views, and a logical series of detailed steps to assemble the main structure and components. We encourage you to study the instructions **before** attempting to assemble your exhibit.

Each page reminds you to tighten the setscrews after disassembling your exhibit to prevent loss of the locks and setscrews (see below in RED). This is VERY IMPORTANT.

Cleaning and Packing Your Display

- 1) Use care when cleaning aluminum extrusion or acrylic inserts. Use only non-abrasive cleaners.
- 2) When cleaning laminate inserts, countertops, or panels use mild cleansers and a soft material such as cotton.
- 3) Keep all display components away from extreme heat and long exposure to sunlight to avoid warping and fading.
- 4) Retain all packing material. It will make re-packing much easier and will reduce the likelihood of shipping damage.

General Setup Instructions for Extrusion System



Most exhibits can be assembled with the supplied Hex Key Tool. Occasionally, a flat head screwdriver may be required.



Most horizontal extrusion connections have a patented expandable lock. This lock inserts into the groove of an opposing extrusion. Tightening the lock with the Hex Key Tool expands the lock and creates a strong positive connection.

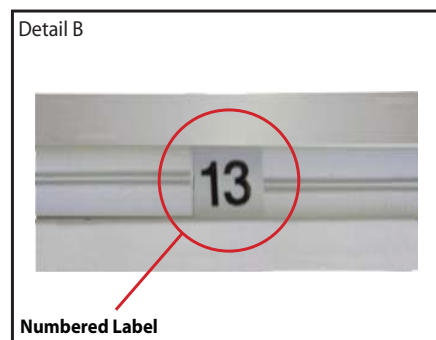

Each extrusion contains a numbered label which corresponds with setup instructions. The label is located within a groove of the extrusion (when possible). With extrusion components the labels contain Black numbers unless otherwise specified.



Remove only (1) setscrew when disassembling. Replace setscrew in extrusion after assembling it. Before packing, replace setscrew in extrusion to avoid losing it.

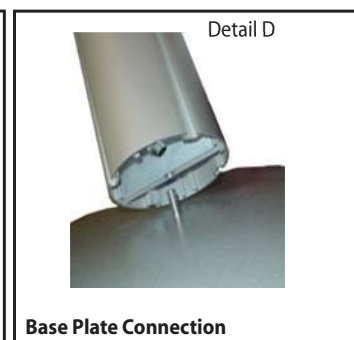

Attach base plate to round or square vertical extrusion using the bolt provided. Be careful not to strip the threads.

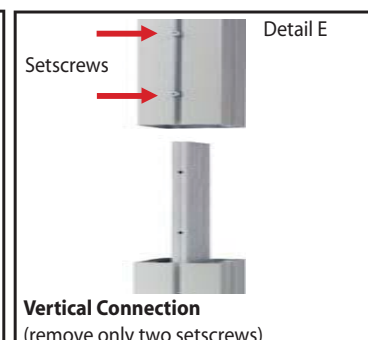

When vertical extrusions are packed in portable cases rather than crates or tubs, they must be broken down into smaller section which then require assembly.

Remove only (2) setscrews when disassembling. Replace setscrews in extrusion after assembling it. Before packing, replace setscrews in extrusion to avoid losing them.

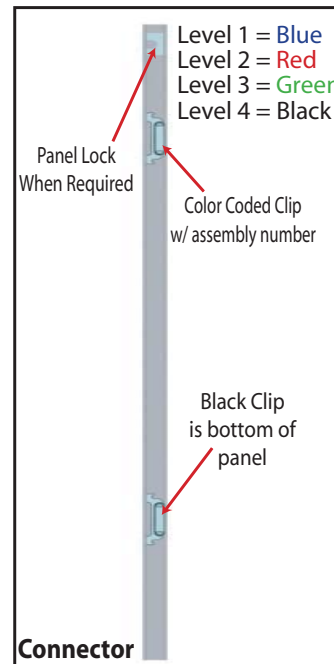

Each component has 2 clips, the lower clip is ALWAYS black. The top clip is color coded to distinguish which level. The color coded clip also contains the numbered label.

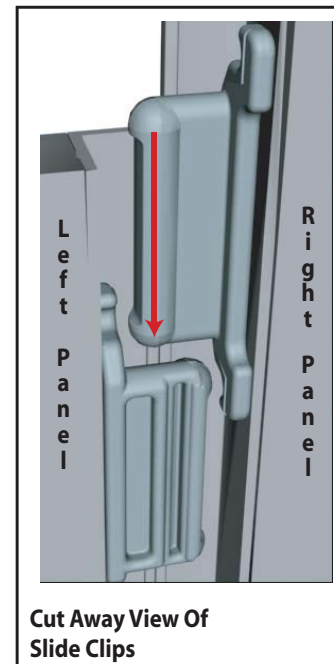

Components connect together by aligning them and sliding downward connecting clips together.

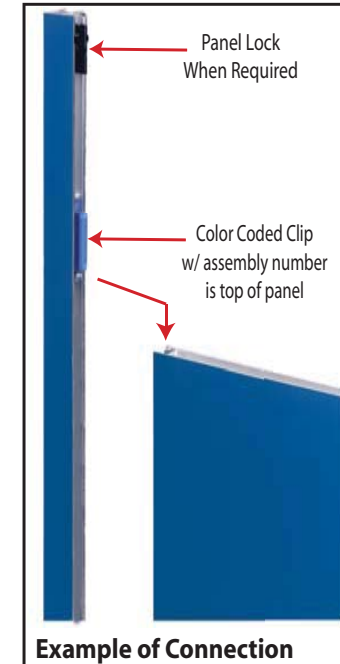

Configurations are assembled from left to right, usually starting with #1 and following the numbered sequence.

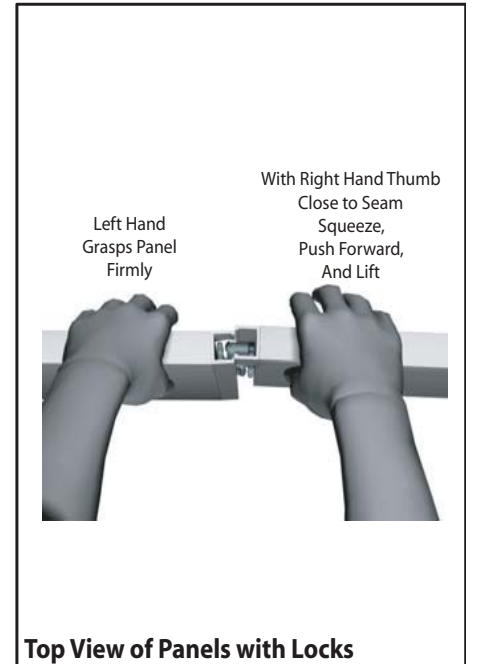

The first level of components contain panel locks that are located at the top of the panel for extra stability and seamless connection. When disassembling panels twist top connection slightly and lift right panel upward.

WHEN DISASSEMBLING ALUMINUM EXTRUSION, TIGHTEN ALL SETSCREWS AND LOCKS TO PREVENT LOSS DURING SHIPPING

Item Number	Description
1	16.25" x 47.5" Angle Cut Panel
2	47.5" T-Connector
3	19" x 47.5" Flat Panel
4	47.5" Combo Connector**Milled**
5	14.125" x 47.5" Flat Panel
6	47.5" 120 Degree Connector
7	23" x 38" Flat panel
8	47.5" Combo Connector**Milled**
9	23" x 47.5" Flat Panel
10	11.5" x 47.5" Flat Panel
11	23" x 47.5" Flat Panel
12	47.5" Combo Connector**Milled**
13	23" x 38" Flat Panel
14	47.5" Combo Connector**Milled**
15	21.428" x 47.5" Flat Panel
16	47.5" T-Connector
17	14.120" x 47.5" Flat Panel
18	14.120" x 47.5" Flat Panel
19	23"r x 47.5" Eighth Curve
20	23"r x 47.5" Eighth Curve
21	16.20" x 47.5" Angle Cut Panel
22	11.970" x 47.5" Flat Panel
23	47.5" 90 Degree Connector
24	13.938" x 47.5" Flat Panel
25	47.5" Combo Connector**Milled**
26	14.125" x 47.5" Flat Panel
27	18.995" x 38" Flat Panel w/ Door
28	18.995" x 38" Flat Panel
29	47.5" Combo Connector**Milled**
30	14.125" x 47.5" Flat Panel
32	21.255" x 47.5" Flat Panel
33	21.255" x 47.5" Flat Panel
34	47.5" Combo Connector**Milled**
35	14.125" x 47.5" Flat Panel
36	18.995" x 38" Flat Panel w/ Door
37	18.995" x 38" Flat Panel
38	23" x 42" Flat Panel
39	23" x 42" Flat Panel
40	9.5"r x 42" Curve Panel
41	19" x 42" Flat Panel
42	9.5"r x 42" Curve Panel
43	9.5"r x 42" Curve Panel
44	9.5"r x 42" Curve Panel
45	42" Square Endcap

Assemble Panels in order starting with #1* as shown in illustration.

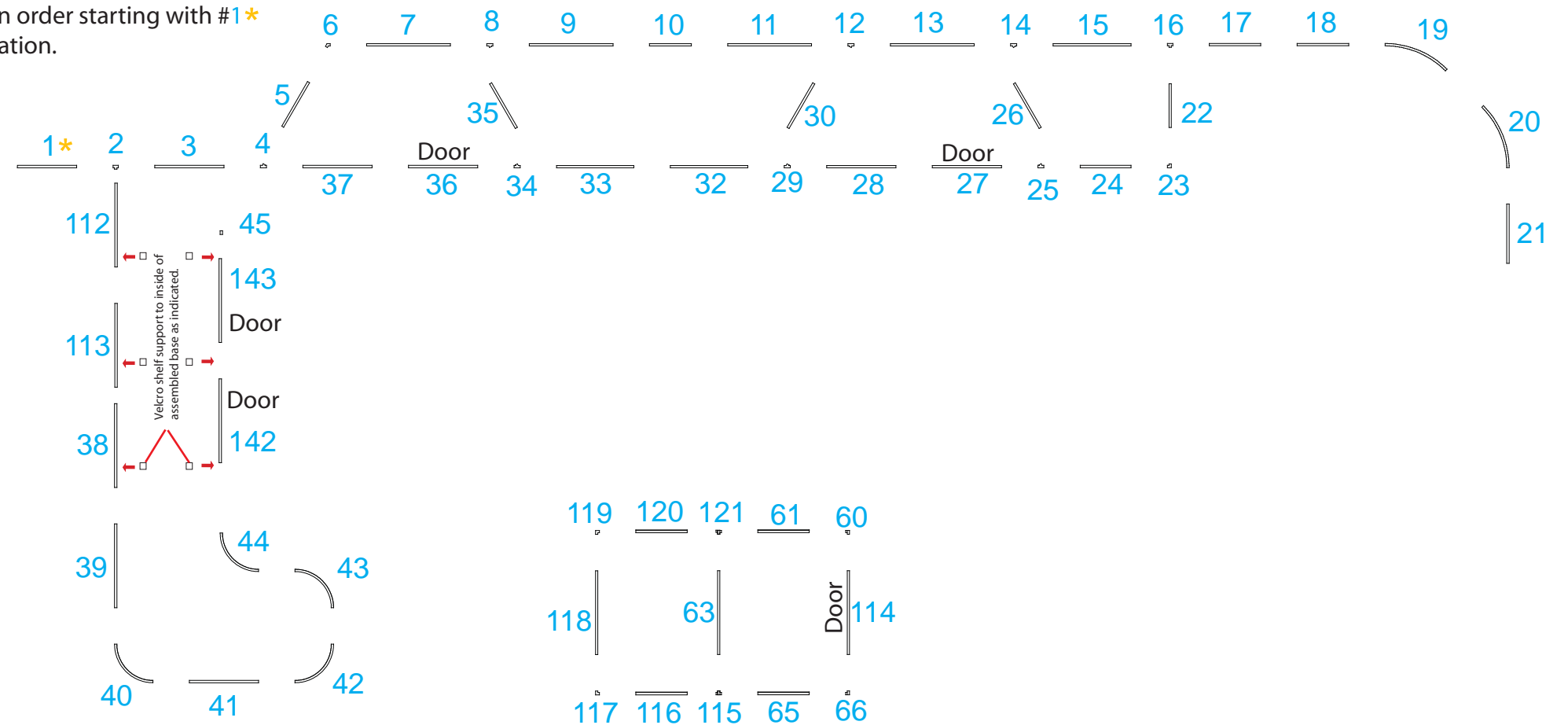

Item Number	Description
60	38" 90 Degree Connector
61	14.125" X 38" Flat Panel
63	23" x 47.5" Flat Panel
65	14.125" X 38" Flat Panel
66	38" 90 Degree Connector
112	23" x 42" Flat Panel
113	23" x 42" Flat Panel
114	23" x 38" Flat Panel w/ Door
115	47.5' T-Connector ***MILLED OFF***
116	14.125" X 47.5" Flat Panel
117	47.5" 90 Degree Connector
118	23" x 47.5" Flat Panel
119	47.5" 90 Degree Connector
120	14.125" X 47.5" Flat Panel
121	47.5' T-Connector ***MILLED OFF***

Item Number	Description
142	23" x 42" Flat Panel w/ Door
143	23" x 42" Flat Panel w/ Door

WHEN DISASSEMBLING ALUMINUM EXTRUSION, TIGHTEN ALL SETSCREWS AND LOCKS TO PREVENT LOSS DURING SHIPPING

Item Number	Description
1	23" x 47.5" Angle Cut Panel
2	47.5" 180 Degree Connector
3	19" x 47.5" Flat Panel
4	47.5" Combo Connector**Milled**
5	14.125" x 47.5" Flat Panel
6	47.5" 120 Degree Connector
7	23" x 42" Flat Lightbox panel
8	47.5" Combo Connector**Milled**
9	23" x 47.5" Flat Panel
10	11.5" x 47.5" Flat Panel
11	23" x 47.5" Flat Panel
12	47.5" Combo Connector**Milled**
13	23" x 42" Flat Lightbox Panel
14	47.5" Combo Connector**Milled**
15	21.428" x 47.5" Flat Panel
16	47.5" T-Connector
17	14.120" x 47.5" Flat Panel
18	14.120" x 47.5" Flat Panel
19	23"r x 47.5" Eighth Curve
20	23"r x 47.5" Eighth Curve
21	23" x 47.5" Angle Cut Panel
22	11.970" x 47.5" Flat Panel
23	47.5" 90 Degree Connector
26	14.125" x 32.5" Flat Panel
29	32.5" 120 Degree Connector
30	14.125" x 32.5" Flat Panel
32	21.255" x 32.5" Angle Cut Flat Panel
33	21.255" x 32.5" Angle Cut Flat Panel
34	23" 120 Degree Connector
35	14.125" x 23" Flat Panel
63	23" x 32.5" Flat Panel
115	47.5" 90° Connector
116	14.125" x 47.5" Flat Panel
117	47.5" 90° Connector
118	23" x 32.5" Flat Panel
119	32.5" 90° Connector
120	14.125" x 32.5" Flat Panel
121	32.5" 90° Connector
144	47.5" 120 Degree Connector
145	13.938" x 47.5" Flat Panel

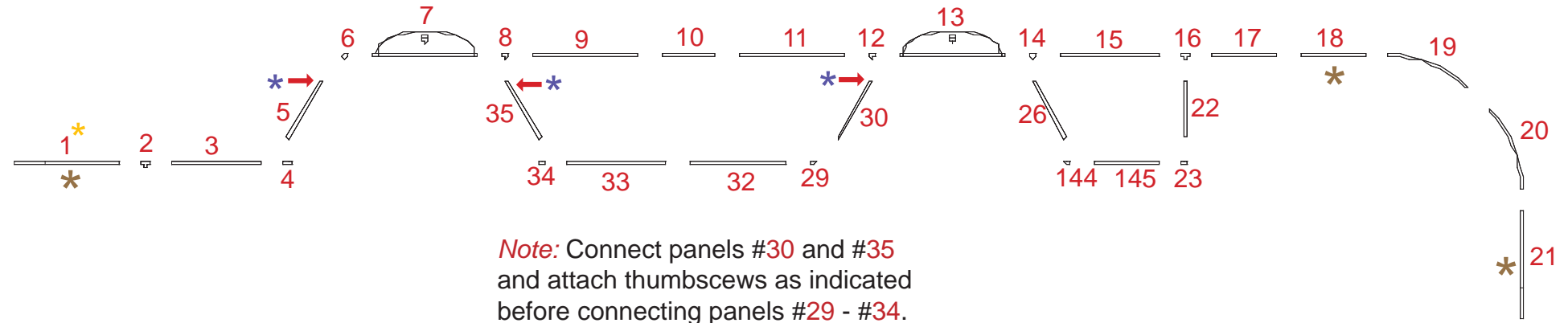

Steps:

- 1) Assemble Panels in order starting with #1* as shown in illustration.
- 2) Attach thumbscrews as indicated for stability.

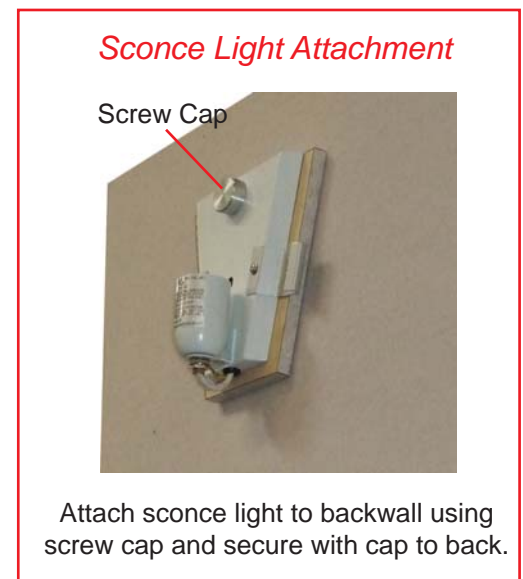
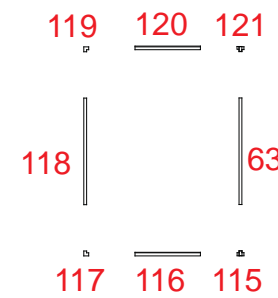

* = Indicates Sconce Light Attachment
 * = Indicates Thumbscrew Attachment

WHEN DISASSEMBLING ALUMINUM EXTRUSION, TIGHTEN ALL SETSCREWS AND LOCKS TO PREVENT LOSS DURING SHIPPING

Item Number	Description
7	23" w x 15" h Flat Panel
13	23" w x 15" h Flat Panel
118	15" h Graphic Frame
118A	15" h Graphic Frame
146	15" h Curved Panel
147	15" h Flat Panel
150	15" High Curved Panel
151	15" Flat Panel
154	Center Connecting Flat Panel

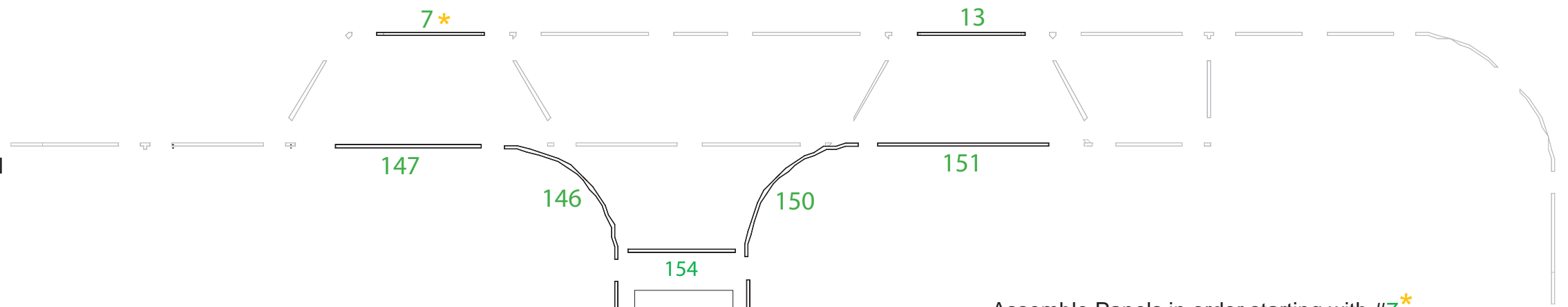

Place ceiling atop lower lip of window panels.

Assemble Panels in order starting with #7* as shown in illustration.

Attach Light Support Bar to tops of panels as shown and attach lights.

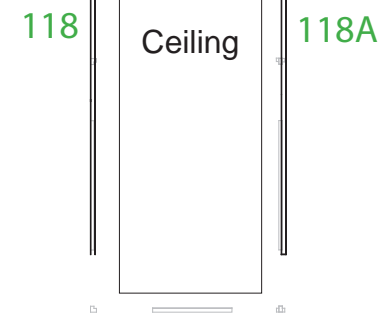
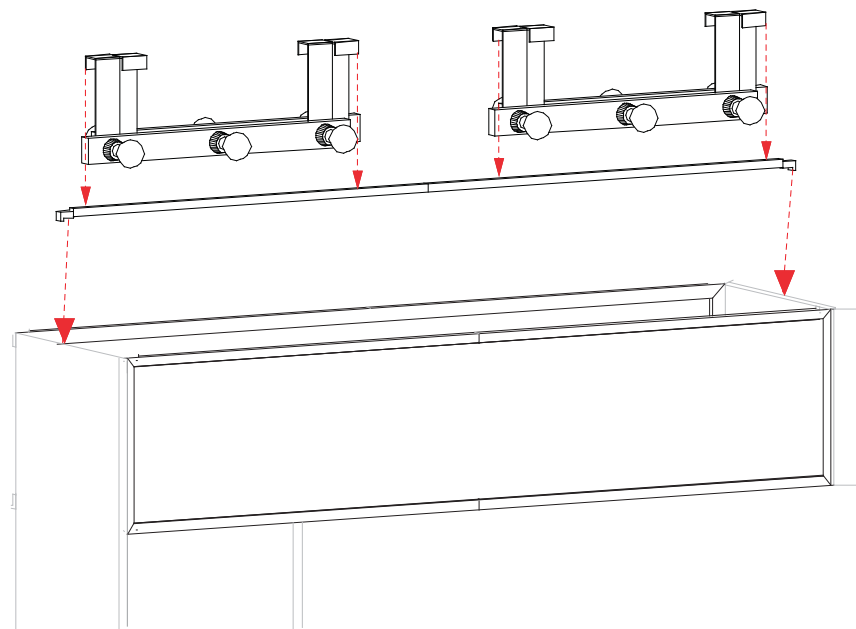

WHEN DISASSEMBLING ALUMINUM EXTRUSION, TIGHTEN ALL SETSCREWS AND LOCKS TO PREVENT LOSS DURING SHIPPING



WHEN DISASSEMBLING ALUMINUM EXTRUSION, TIGHTEN ALL SETSCREWS AND LOCKS TO PREVENT LOSS DURING SHIPPING

866.652.2100

Item Number	Description	Item Number	Description
46	38" End Cap	67	38" T-Connector
47	38" 90° Connector	68	23" x 38" Flat Panel
48	19" x 38" Window Panel	69	38" T-Connector
49	19" x 38" Window Panel	70	14.125" x 38" Flat Panel
50	19" x 38" Window Panel	71	38" 90° Connector
51	19" x 38" Graphic Panel	72	23" x 38" Flat Panel
		73	38" 90° Connector
53	19" x 38" Window Panel	74	14.125" x 38" Flat Panel
54	19" x 38" Window Panel	75	19" x 38" Window Panel
55	19" x 38" Graphic Panel	76	19" x 38" Window Panel
		77	19" x 38" Window Panel
58	19" x 38" Window Panel	79	19" x 38" Window Panel
		80	38" Tapered Panel
		81	38" Tapered Panel
		110	38" 135° Connector
		111	38" 135° Connector

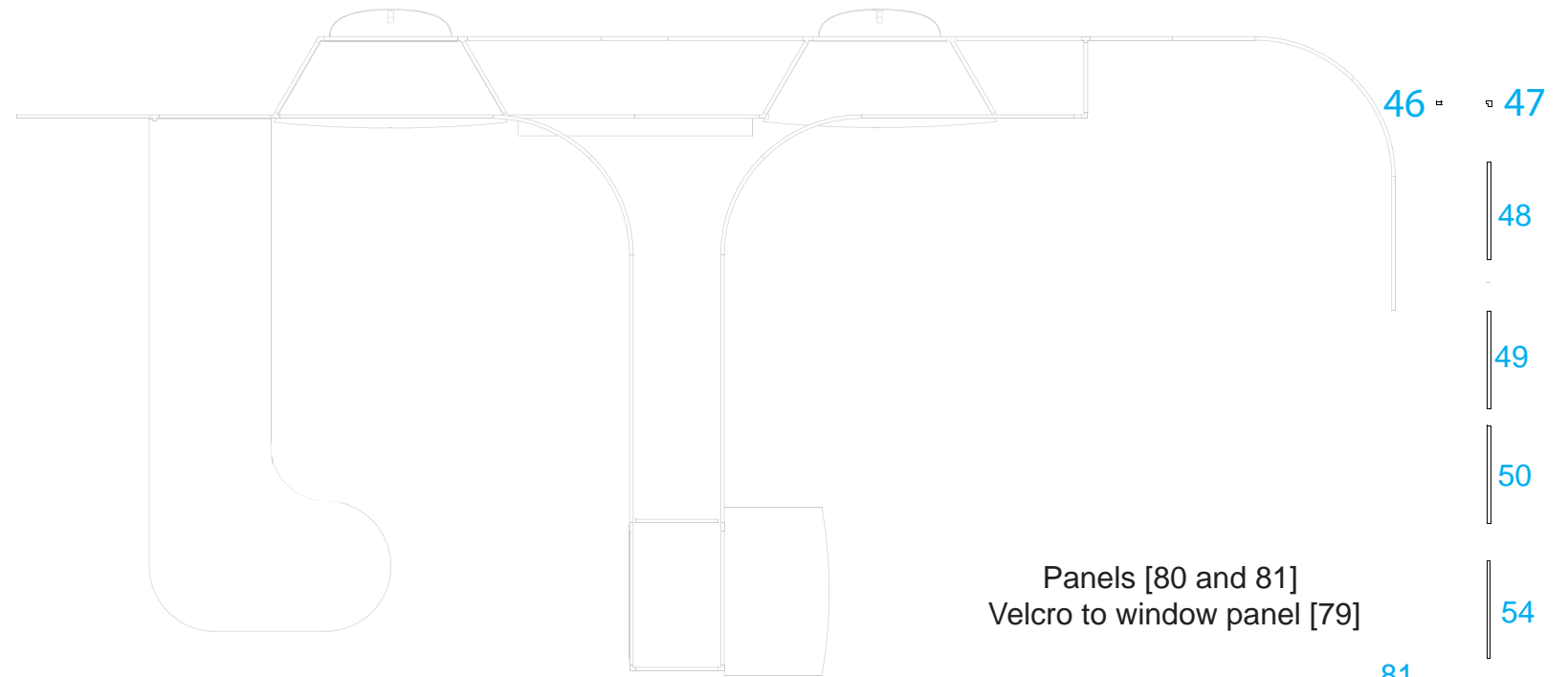

Place decorative cap [C, E, B, F and G] on top of assembled wall as shown. Then place Counters atop assembled Pedestals.

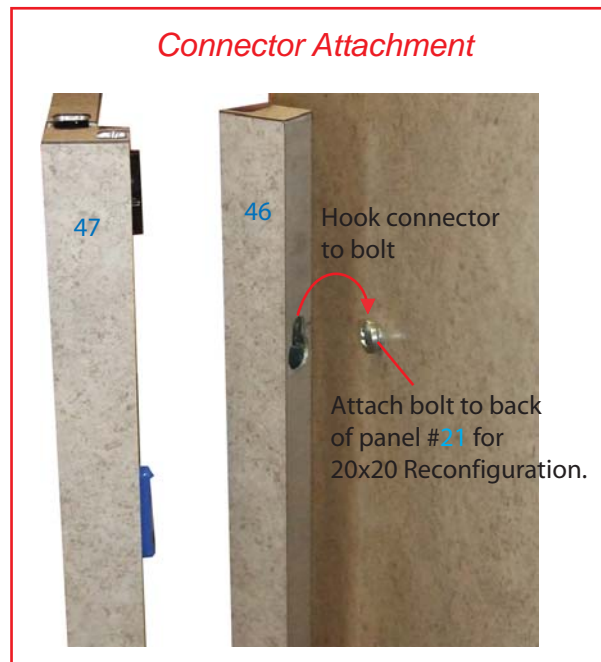
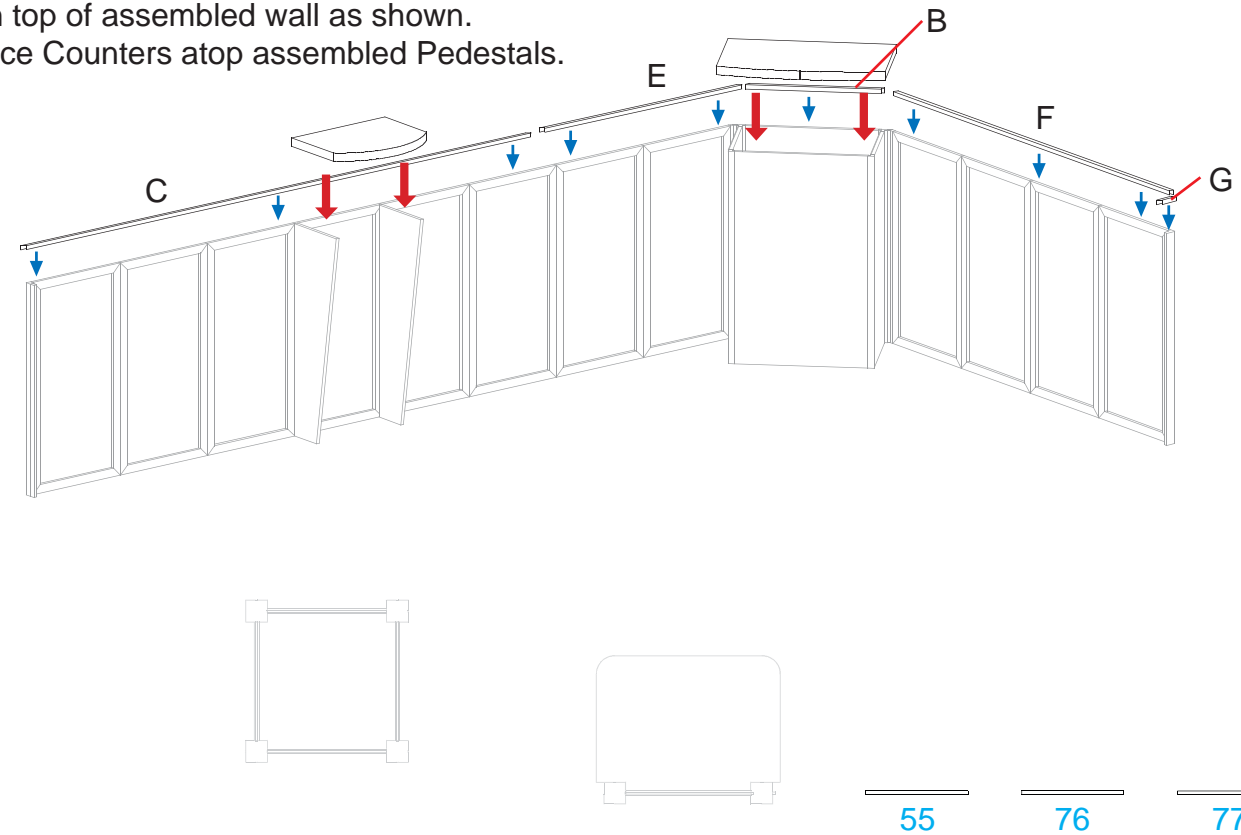

WHEN DISASSEMBLING ALUMINUM EXTRUSION, TIGHTEN ALL SETSCREWS AND LOCKS TO PREVENT LOSS DURING SHIPPING

866.652.2100

Part Number	Qty for Step	Description
13	1	84"h Vertical Extrusion
13A	1	38"h Vertical Extrusion w/ Door Stop
13B	1	38"h Vertical Extrusion w/ Door Hinges
13C	1	84"h Vertical Extrusion w/ Attached Endcap
14	4	20.5" Horizontal Extrusion
15	4	16" Horizontal Extrusion

Steps

- 1) Attach lower horizontal extrusions [14 and 15] between vertical extrusions [13, 13A, 13B and 13C] as shown below.
- 2) Place large insert and attach upper horizontal [14] between vertical extrusions [13 and 13C] and atop insert.
- 3) Place smaller inserts and door as indicated below.
- 4) Attach upper horizontals [14 and 15] between verticals [13, 13A, 13B and 13C] and atop inserts and door as shown.
- 5) Place Counter atop assembled pedestal.

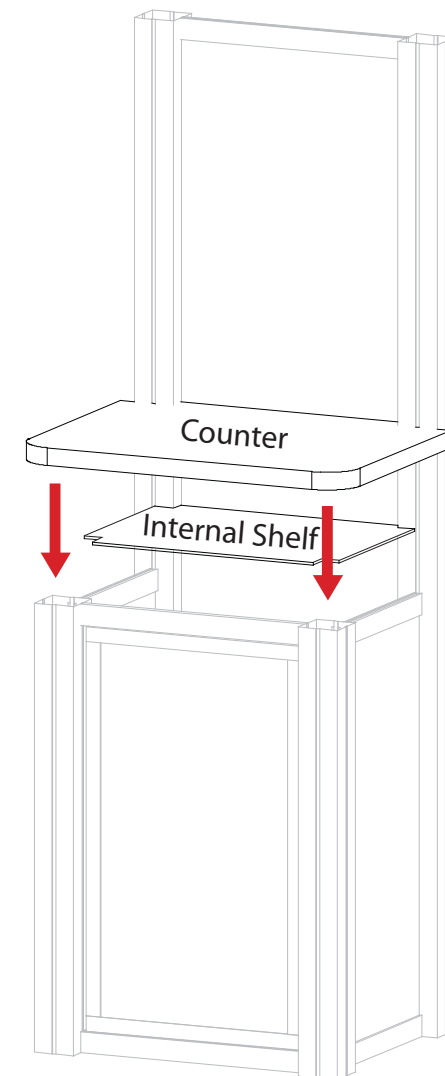
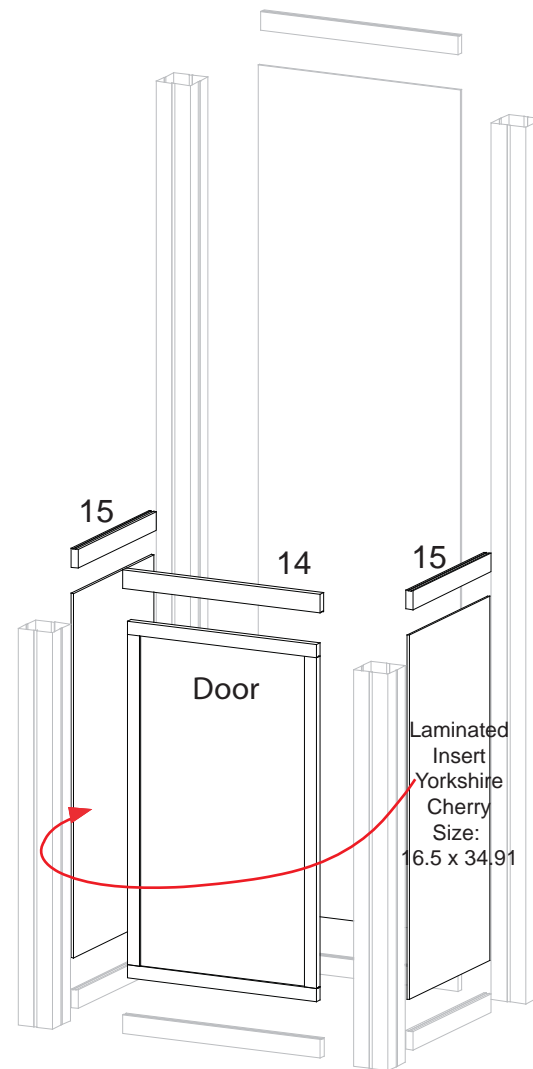
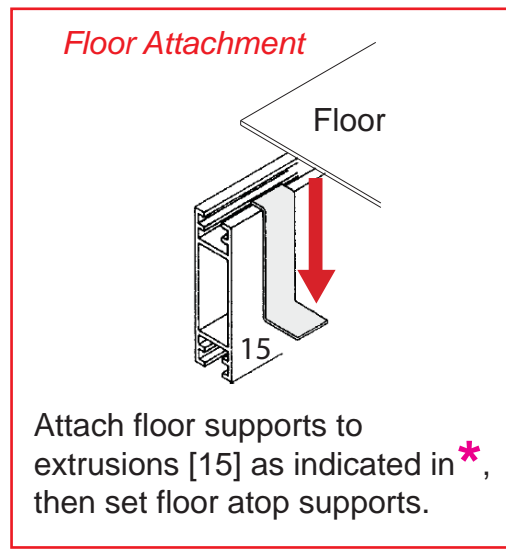
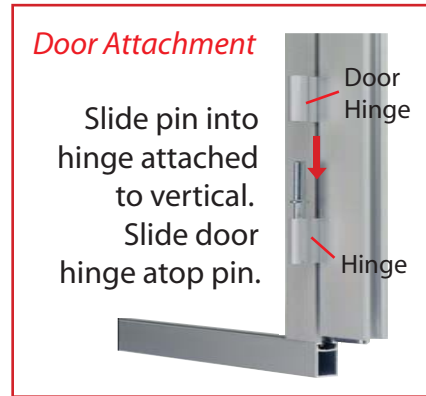
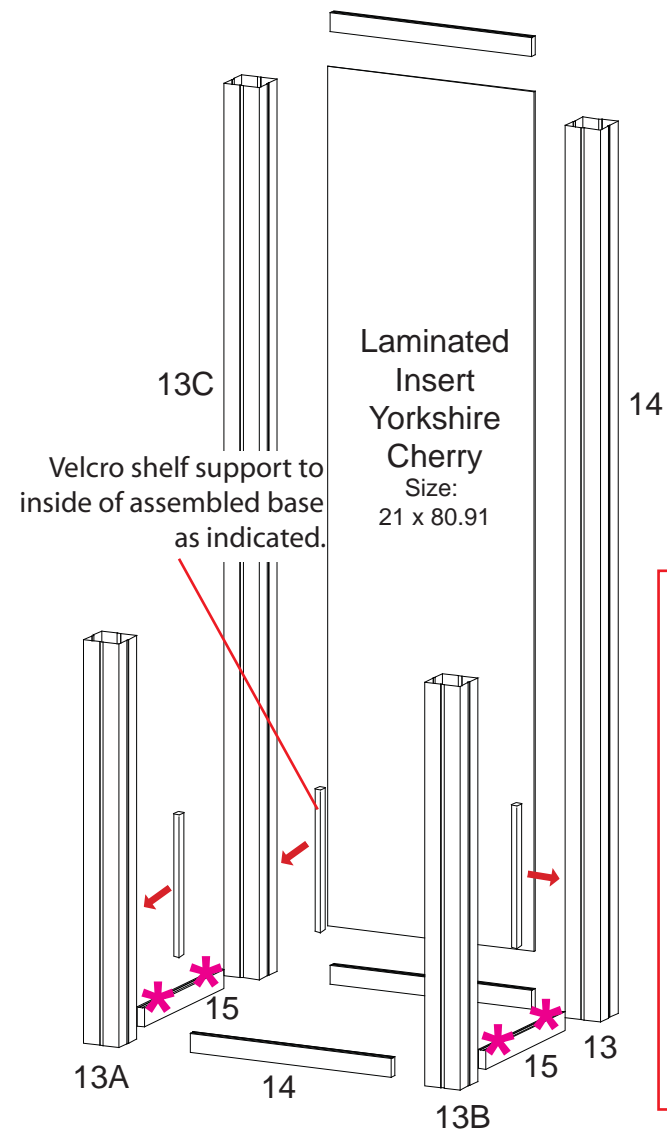
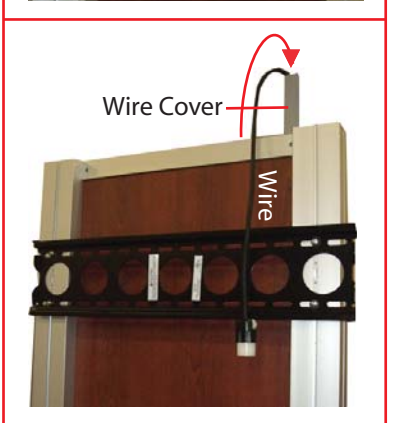
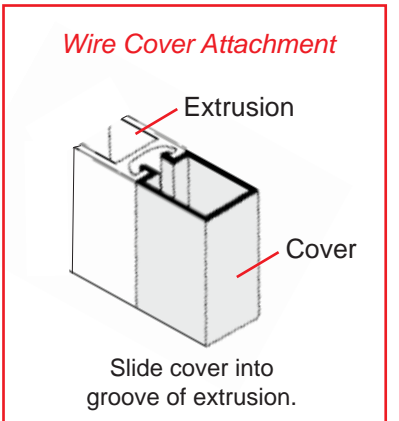
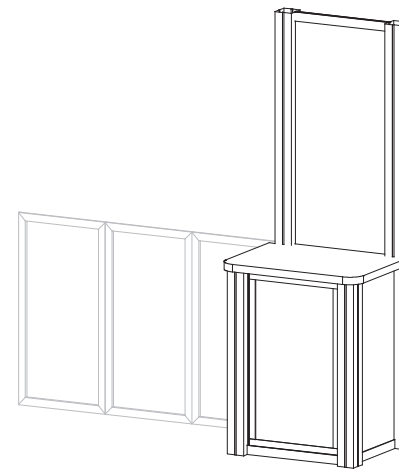

WHEN DISASSEMBLING ALUMINUM EXTRUSION, TIGHTEN ALL SETSCREWS AND LOCKS TO PREVENT LOSS DURING SHIPPING

866.652.2100

Part Number	Qty for Step	Description
16	4	96" Vertical Extrusion w/ Slideable Connectors Attached
17	4	19.5" Horizontal Extrusion
18	4	19.5" Horizontal Extrusion

Steps

- 1) Attach lower horizontal extrusions [17] between vertical extrusions [16] as shown below.
Note: Slide connector UP to allow horizontal bar to attach to vertical post.
- 2) Attach upper horizontal extrusions [18] between vertical extrusions [16].
- 3) Attach Graphics.

Velcro facing outside of tower.

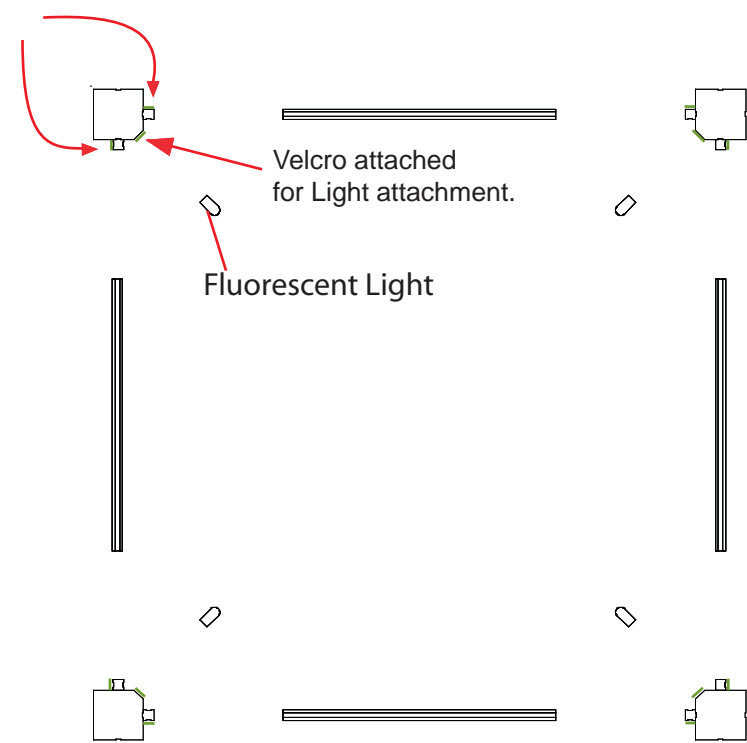

Fluorescent Light

Plan View

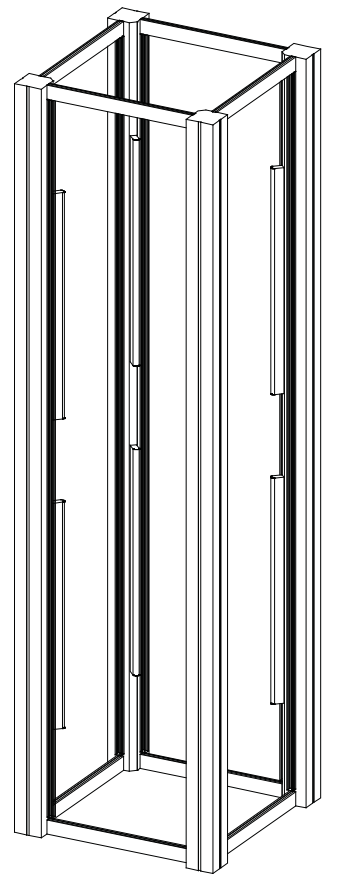
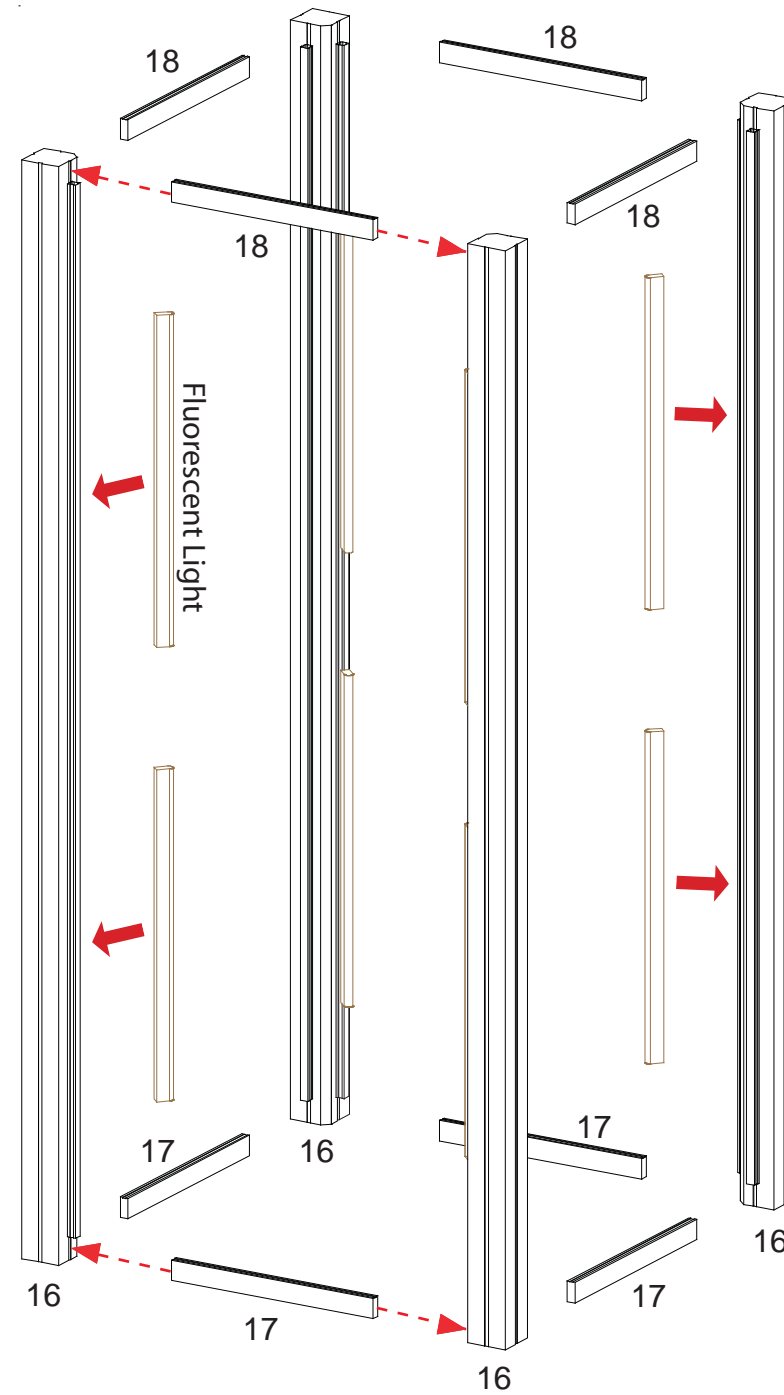

WHEN DISASSEMBLING ALUMINUM EXTRUSION, TIGHTEN ALL SETSCREWS AND LOCKS TO PREVENT LOSS DURING SHIPPING