

euro It | *HYBRIDS*

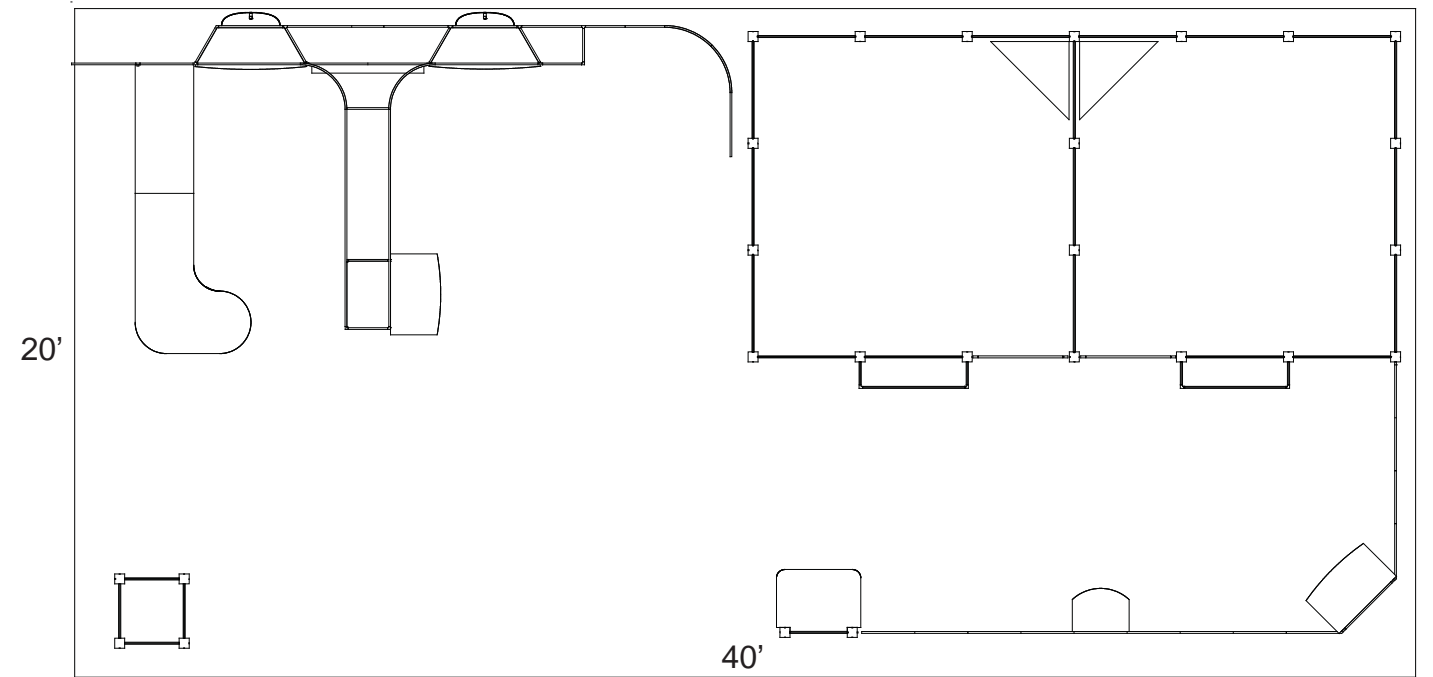

Plan View

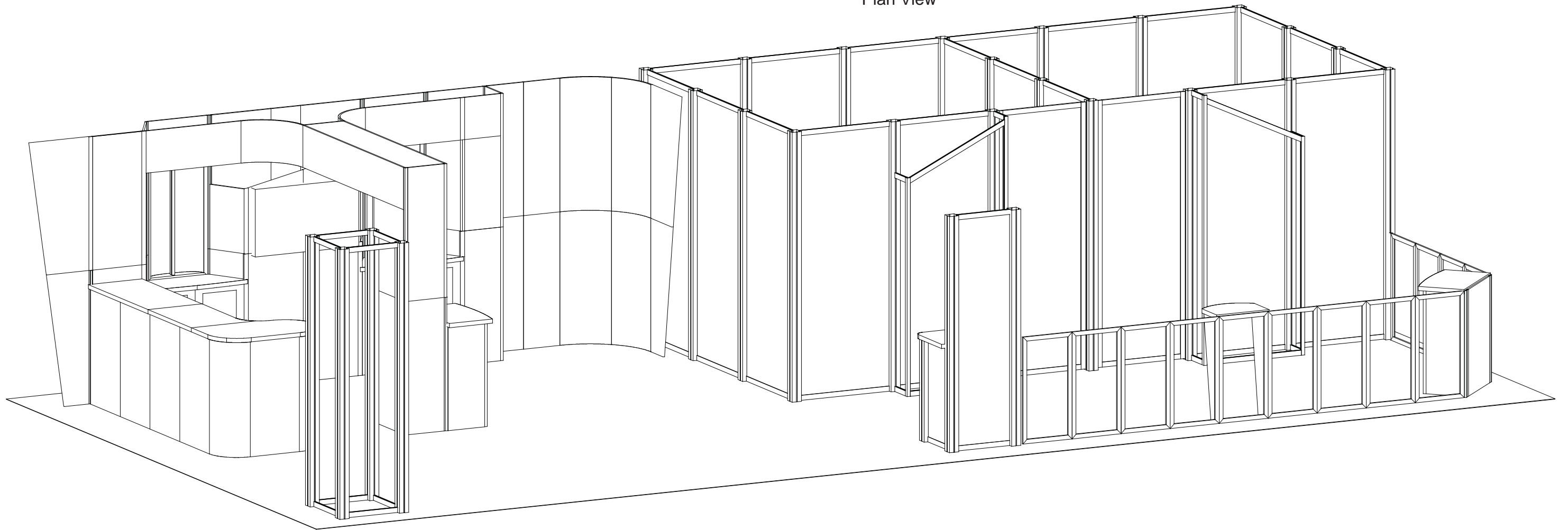

WHEN DISASSEMBLING ALUMINUM EXTRUSION, TIGHTEN ALL SETSCREWS AND LOCKS TO PREVENT LOSS DURING SHIPPING

euro lt | HYBRIDS

Using Your Setup Instructions

The Euro LT Hybrids Setup Instructions are created specifically for your configuration. They are laid out sequentially in levels, including exploded views, and a logical series of detailed steps to assemble the main structure and components. We encourage you to study the instructions **before** attempting to assemble your exhibit.

Each page reminds you to tighten the setscrews after disassembling your exhibit to prevent loss of the locks and setscrews (see below in RED). This is VERY IMPORTANT.

Cleaning and Packing Your Display

- 1) Use care when cleaning aluminum extrusion or acrylic inserts. Use only non-abrasive cleaners.
- 2) When cleaning laminate inserts, countertops, or panels use mild cleansers and a soft material such as cotton.
- 3) Keep all display components away from extreme heat and long exposure to sunlight to avoid warping and fading.
- 4) Retain all packing material. It will make re-packing much easier and will reduce the likelihood of shipping damage.

General Setup Instructions for Extrusion System



The Tool

Most exhibits can be assembled with the supplied Hex Key Tool. Occasionally, a flat head screwdriver may be required.



Typical Connection

Most horizontal extrusion connections have a patented expandable lock. This lock inserts into the groove of an opposing extrusion. Tightening the lock with the Hex Key Tool expands the lock and creates a strong positive connection.



Typical Connection (cont'd)

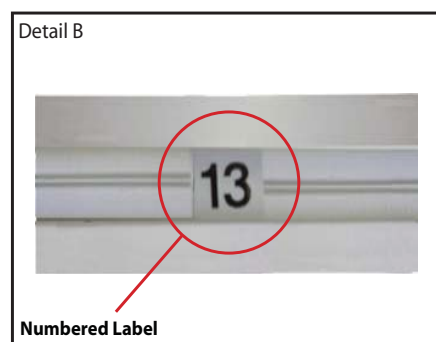

Numbered Label

Each extrusion contains a numbered label which corresponds with setup instructions. The label is located within a groove of the extrusion (when possible). With extrusion components the labels contain Black numbers unless otherwise specified.

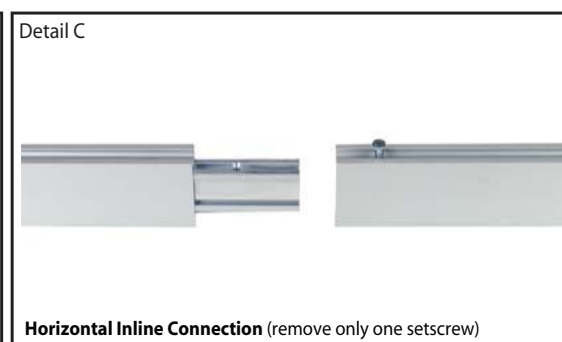

Horizontal Inline Connection (remove only one setscrew)

Remove only (1) setscrew when disassembling. Replace setscrew in extrusion after assembling it. Before packing, replace setscrew in extrusion to avoid losing it.

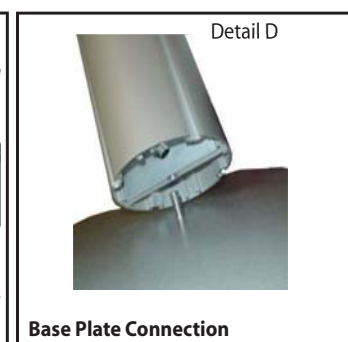

Base Plate Connection

Attach base plate to round or square vertical extrusion using the bolt provided. Be careful not to strip the threads.

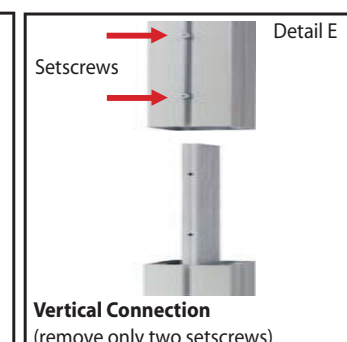

Vertical Connection (remove only two setscrews)

When vertical extrusions are packed in portable cases rather than crates or tubs, they must be broken down into smaller section which then require assembly.

Remove only (2) setscrews when disassembling. Replace setscrews in extrusion after assembling it. Before packing, replace setscrews in extrusion to avoid losing them.

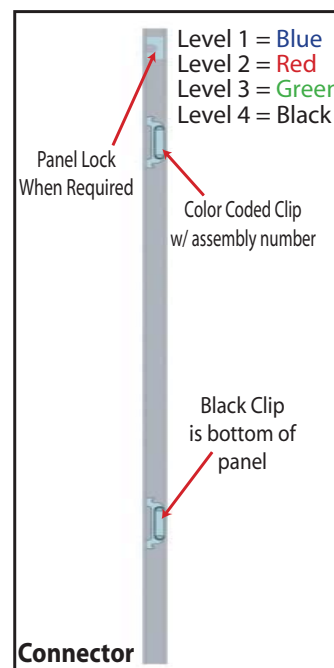

Connector

Each component has 2 clips, the lower clip is ALWAYS black. The top clip is color coded to distinguish which level. The color coded clip also contains the numbered label.

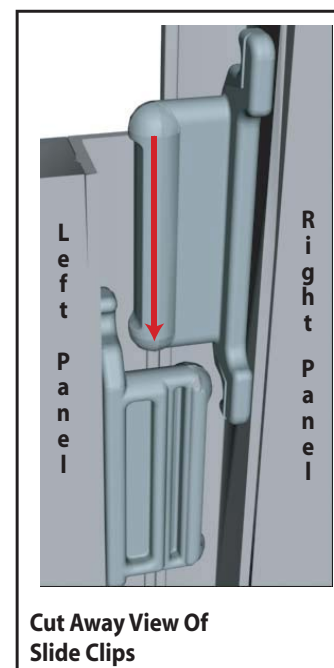

Cut Away View Of Slide Clips

Components connect together by aligning them and sliding downward connecting clips together.

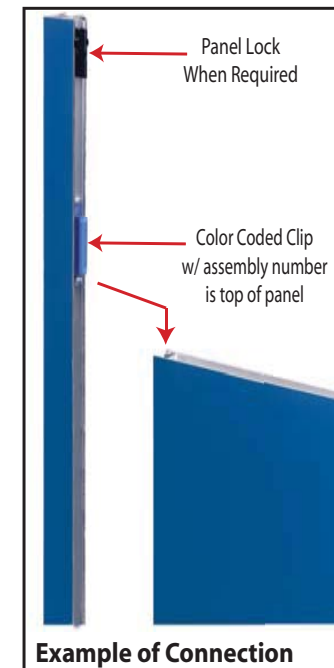

Example of Connection

Configurations are assembled from left to right, usually starting with #1 and following the numbered sequence.

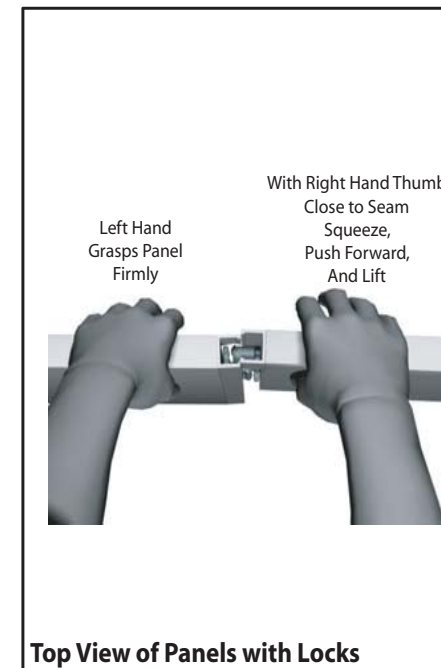

Top View of Panels with Locks

The first level of components contain panel locks that are located at the top of the panel for extra stability and seamless connection. When disassembling panels twist top connection slightly and lift right panel upward.

WHEN DISASSEMBLING ALUMINUM EXTRUSION, TIGHTEN ALL SETSCREWS AND LOCKS TO PREVENT LOSS DURING SHIPPING

Item Number	Description
1	16.25" x 47.5" Angle Cut Panel
2	47.5" T-Connector
3	19" x 47.5" Flat Panel
4	47.5" Combo Connector**Milled**
5	14.125" x 47.5" Flat Panel
6	47.5" 120 Degree Connector
7	23" x 38" Flat panel
8	47.5" Combo Connector**Milled**
9	23" x 47.5" Flat Panel
10	11.5" x 47.5" Flat Panel
11	23" x 47.5" Flat Panel
12	47.5" Combo Connector**Milled**
13	23" x 38" Flat Panel
14	47.5" Combo Connector**Milled**
15	21.428" x 47.5" Flat Panel
16	47.5" T-Connector
17	14.120" x 47.5" Flat Panel
18	14.120" x 47.5" Flat Panel
19	23"r x 47.5" Eighth Curve
20	23"r x 47.5" Eighth Curve
21	16.20" x 47.5" Angle Cut Panel
22	11.970" x 47.5" Flat Panel
23	47.5" 90 Degree Connector
24	13.938" x 47.5" Flat Panel
25	47.5" Combo Connector**Milled**
26	14.125" x 47.5" Flat Panel
27	18.995" x 38" Flat Panel w/ Door
28	18.995" x 38" Flat Panel
29	47.5" Combo Connector**Milled**
30	14.125" x 47.5" Flat Panel
32	21.255" x 47.5" Flat Panel
33	21.255" x 47.5" Flat Panel
34	47.5" Combo Connector**Milled**
35	14.125" x 47.5" Flat Panel
36	18.995" x 38" Flat Panel w/ Door
37	18.995" x 38" Flat Panel
38	23" x 42" Flat Panel
39	23" x 42" Flat Panel
40	9.5"r x 42" Curve Panel
41	19" x 42" Flat Panel
42	9.5"r x 42" Curve Panel
43	9.5"r x 42" Curve Panel
44	9.5"r x 42" Curve Panel
45	42" Square Endcap

Assemble Panels in order starting with #1* as shown in illustration.

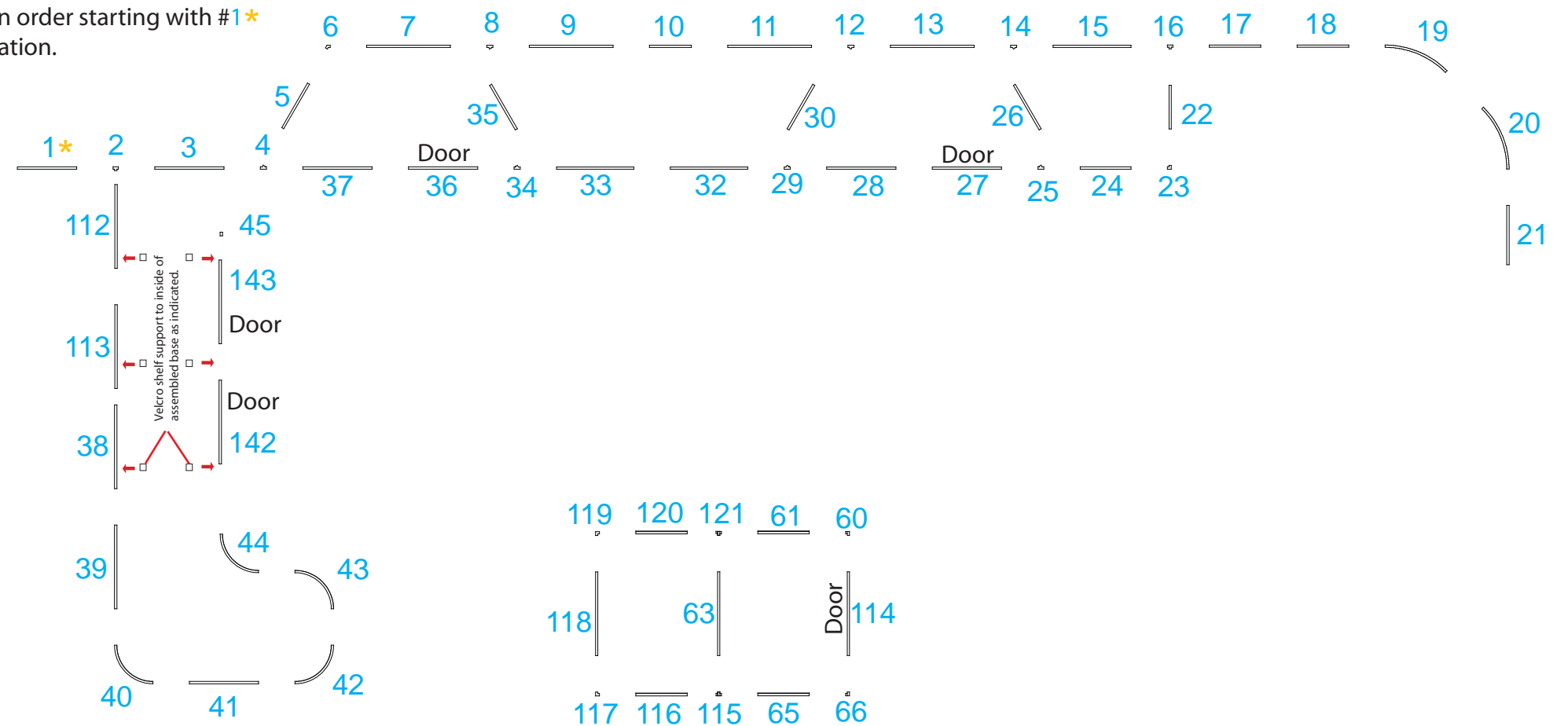

Item Number	Description
60	38" 90 Degree Connector
61	14.125" X 38" Flat Panel
63	23" x 47.5" Flat Panel
65	14.125" X 38" Flat Panel
66	38" 90 Degree Connector
112	23" x 42" Flat Panel
113	23" x 42" Flat Panel
114	23" x 38" Flat Panel w/ Door
115	47.5" T-Connector ***MILLED OFF***
116	14.125" X 47.5" Flat Panel
117	47.5" 90 Degree Connector
118	23" x 47.5" Flat Panel
119	47.5" 90 Degree Connector
120	14.125" X 47.5" Flat Panel
121	47.5" T-Connector ***MILLED OFF***

Item Number	Description
142	23" x 42" Flat Panel w/ Door
143	23" x 42" Flat Panel w/ Door

WHEN DISASSEMBLING ALUMINUM EXTRUSION, TIGHTEN ALL SETSCREWS AND LOCKS TO PREVENT LOSS DURING SHIPPING

Item Number	Description
1	23" x 47.5" Angle Cut Panel
2	47.5" 180 Degree Connector
3	19" x 47.5" Flat Panel
4	47.5" Combo Connector**Milled**
5	14.125" x 47.5" Flat Panel
6	47.5" 120 Degree Connector
7	23" x 42" Flat Lightbox panel
8	47.5" Combo Connector**Milled**
9	23" x 47.5" Flat Panel
10	11.5" x 47.5" Flat Panel
11	23" x 47.5" Flat Panel
12	47.5" Combo Connector**Milled**
13	23" x 42" Flat Lightbox Panel
14	47.5" Combo Connector**Milled**
15	21.428" x 47.5" Flat Panel
16	47.5" T-Connector
17	14.120" x 47.5" Flat Panel
18	14.120" x 47.5" Flat Panel
19	23"r x 47.5" Eighth Curve
20	23"r x 47.5" Eighth Curve
21	23" x 47.5" Angle Cut Panel
22	11.970" x 47.5" Flat Panel
23	47.5" 90 Degree Connector
26	14.125" x 32.5" Flat Panel
29	32.5" 120 Degree Connector
30	14.125" x 32.5" Flat Panel
32	21.255" x 32.5" Angle Cut Flat Panel
33	21.255" x 32.5" Angle Cut Flat Panel
34	23" 120 Degree Connector
35	14.125" x 23" Flat Panel
63	23" x 32.5" Flat Panel
115	47.5" 90° Connector
116	14.125" x 47.5" Flat Panel
117	47.5" 90° Connector
118	23" x 32.5" Flat Panel
119	32.5" 90° Connector
120	14.125" x 32.5" Flat Panel
121	32.5" 90° Connector
144	47.5" 120 Degree Connector
145	13.938" x 47.5" Flat Panel

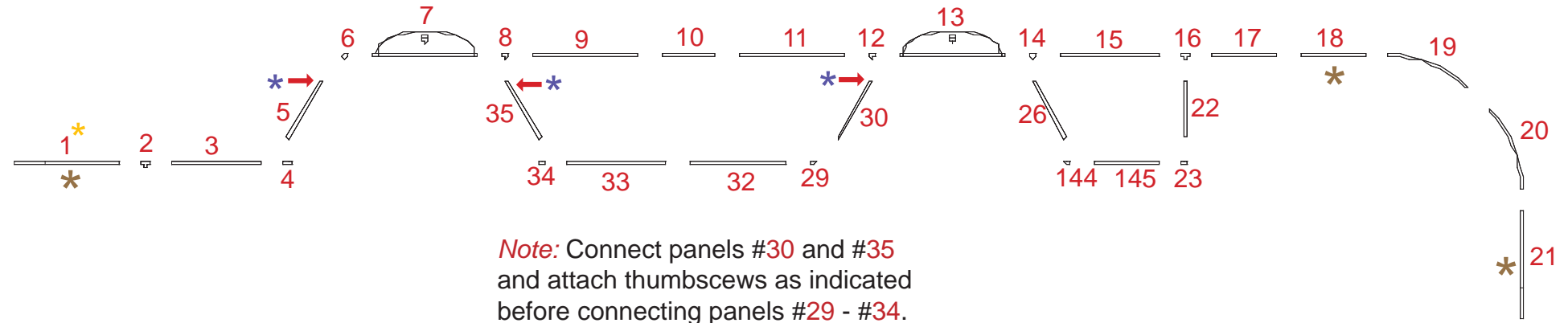

Steps:

- 1) Assemble Panels in order starting with #1* as shown in illustration.
- 2) Attach thumbscrews as indicated for stability.

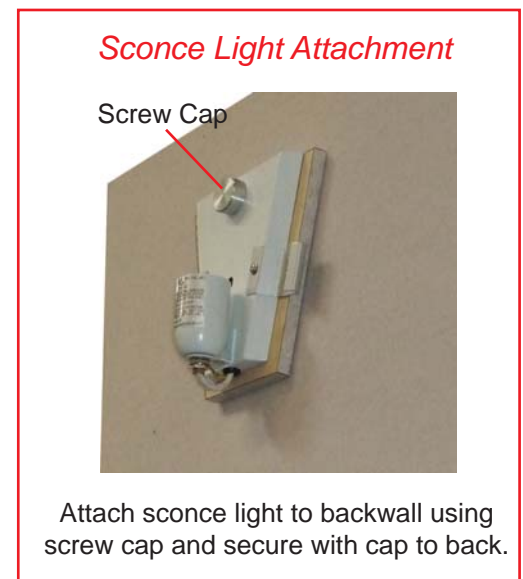
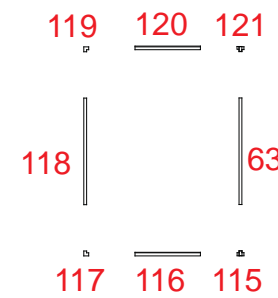

* = Indicates Sconce Light Attachment
 * = Indicates Thumbscrew Attachment

WHEN DISASSEMBLING ALUMINUM EXTRUSION, TIGHTEN ALL SETSCREWS AND LOCKS TO PREVENT LOSS DURING SHIPPING

Item Number	Description
7	23" w x 15" h Flat Panel
13	23" w x 15" h Flat Panel
118	15" h Graphic Frame
118A	15" h Graphic Frame
146	15" h Curved Panel
147	15" h Flat Panel
150	15" High Curved Panel
151	15" Flat Panel
154	Center Connecting Flat Panel

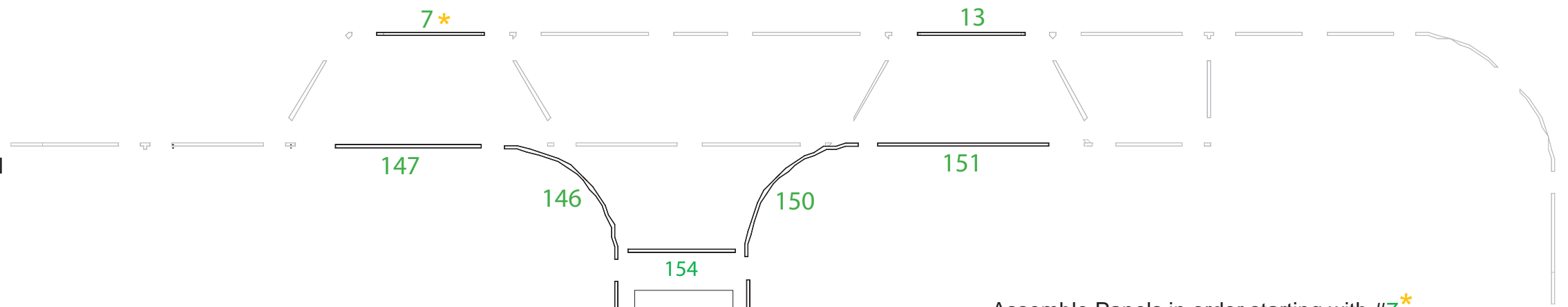

Place ceiling atop lower lip of window panels.

Assemble Panels in order starting with #7* as shown in illustration.

Attach Light Support Bar to tops of panels as shown and attach lights.

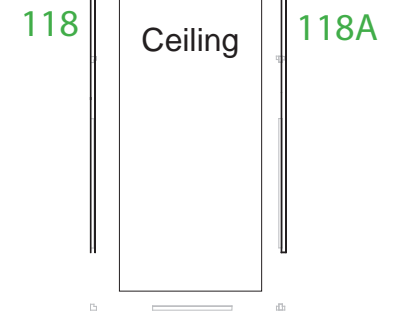
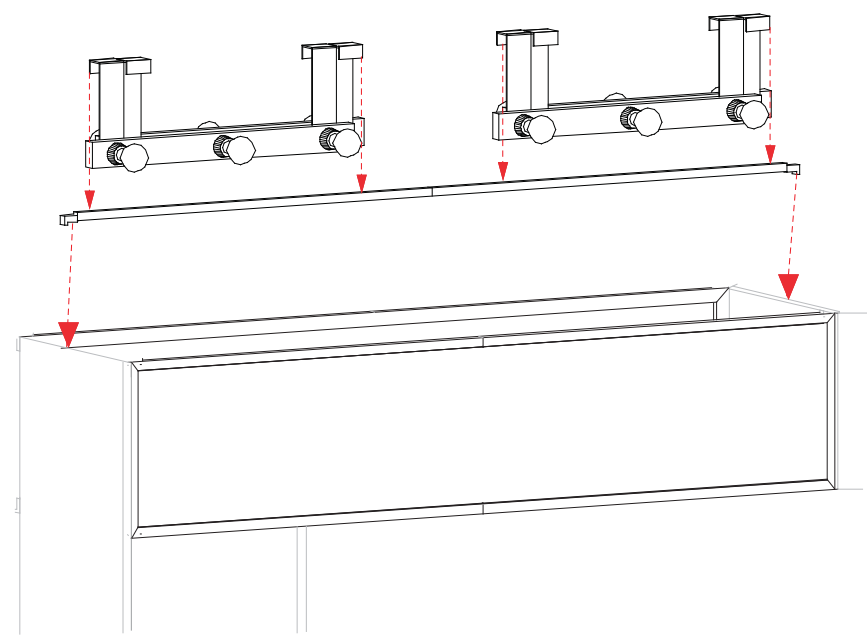

WHEN DISASSEMBLING ALUMINUM EXTRUSION, TIGHTEN ALL SETSCREWS AND LOCKS TO PREVENT LOSS DURING SHIPPING



WHEN DISASSEMBLING ALUMINUM EXTRUSION, TIGHTEN ALL SETSCREWS AND LOCKS TO PREVENT LOSS DURING SHIPPING

866.652.2100

Part Number	Qty for Step	Description
1	7	96" h Vertical Extrusion
2	12	34.75" Horizontal Extrusion

Steps

- 1) Attach lower horizontal extrusions [2] between vertical extrusions [1] as shown below.
- 2) Place inserts as indicated.
- 3) Attach upper horizontal extrusions [2] between vertical extrusions [1] and atop inserts.

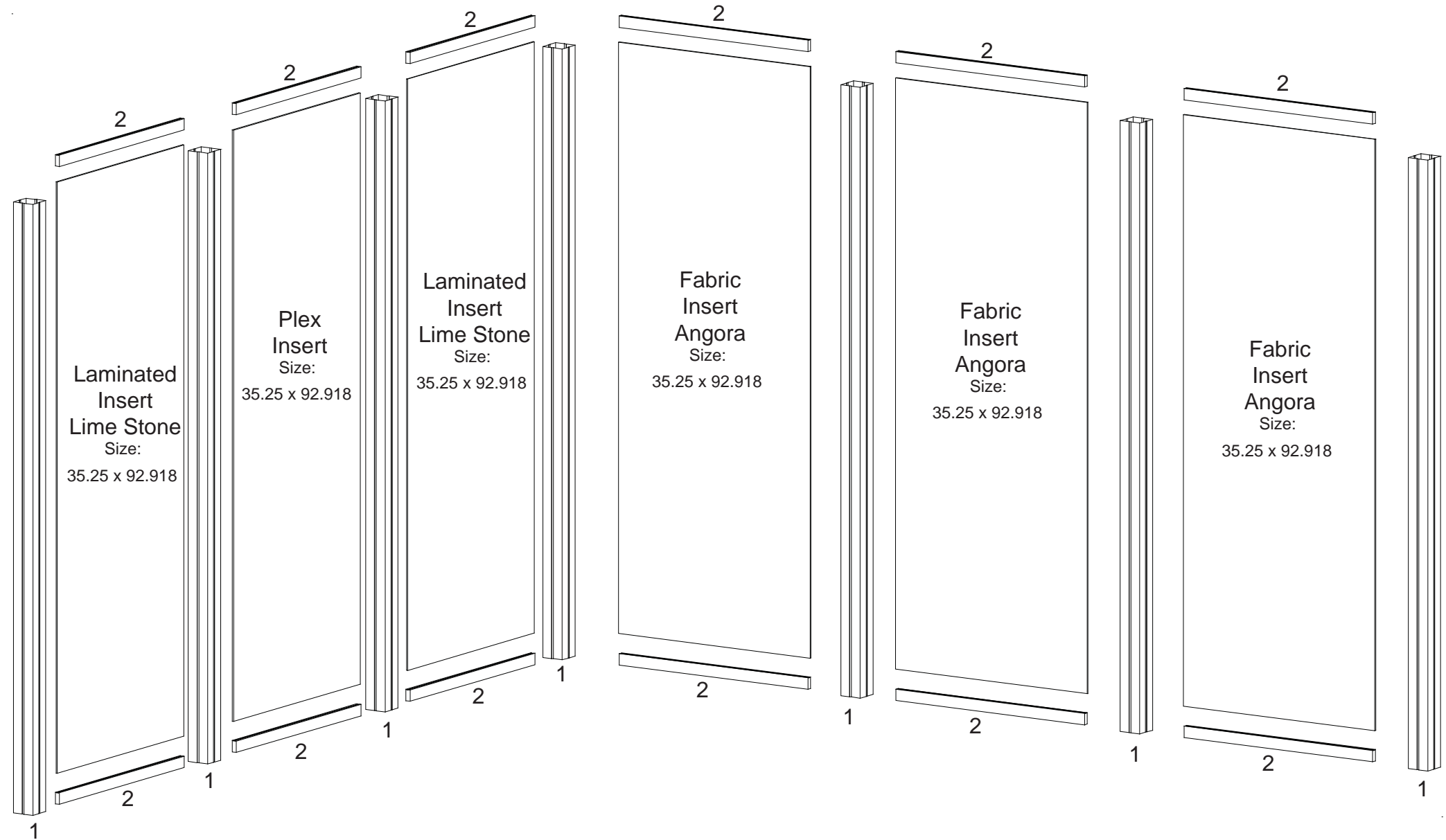
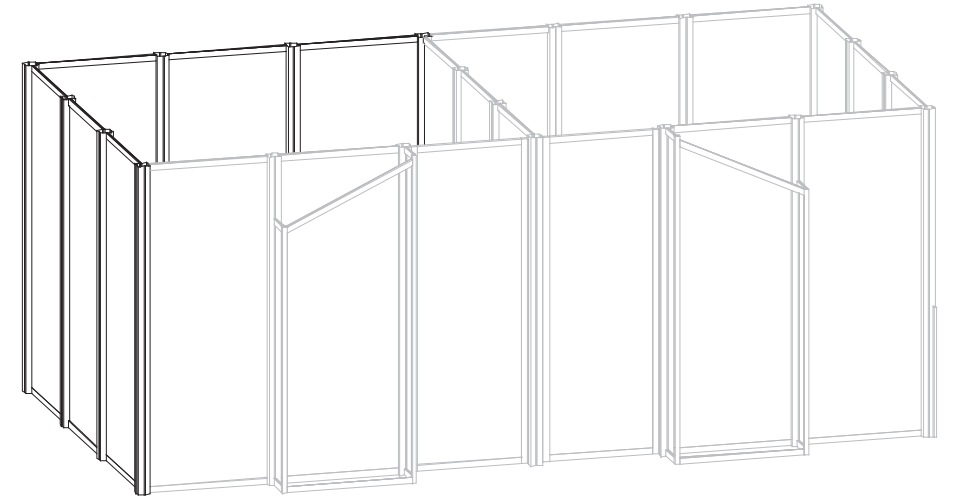

WHEN DISASSEMBLING ALUMINUM EXTRUSION, TIGHTEN ALL SETSCREWS AND LOCKS TO PREVENT LOSS DURING SHIPPING

866.652.2100

Part Number	Qty for Step	Description
1	3	96"h Vertical Extrusion
1A/1B	1/1	96"h Vertical Extrusion w/ Door Hardware
2	11	34.75" Horizontal Extrusion
3	4	12" Horizontal Extrusion
4	1	77.776"h 90° Vertical Extrusion Tapered at Top
5	1	96"h 90° Vertical Extrusion Tapered at Top
6	1	36.541" Horizontal Extrusion
7	1	40.319" Horizontal Extrusion Tapered at Both Ends

Steps

- 1) Attach lower horizontal extrusions [2] between vertical extrusions [1, 1A and 1B] as shown below.
- 2) Place inserts and Door as indicated.
- 3) Attach upper horizontal extrusions [2] between vertical extrusions [1, 1A and 1B] and atop inserts.
- 4) Attach lower extrusions [3 and 6] between vertical extrusions [1, 1B, 4 and 5].
- 5) Place inserts as indicated.
- 6) Connect upper horizontal extrusions [3] between vertical extrusions [1, 1B, 4 and 5] and atop inserts.
- 7) Connect tapered extrusion [7] between verticals [4 and 5] making sure it is flush with top of extrusions.
- 8) Apply Graphics to Velcro on Backside of verticals [4, 5, 6 and 7].

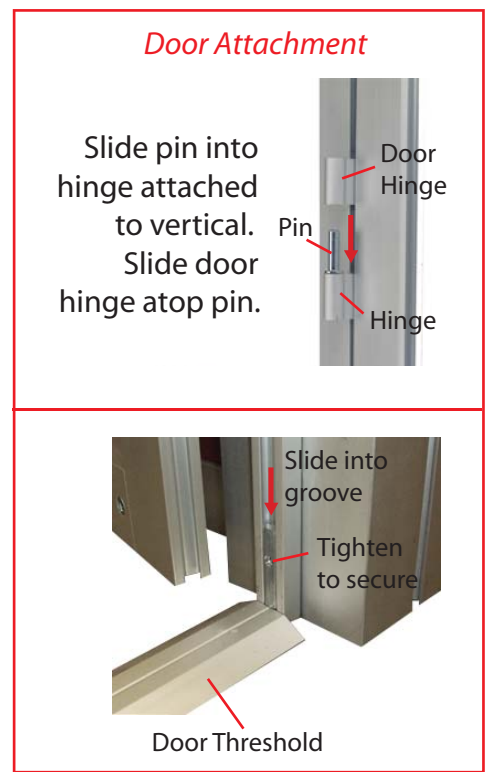
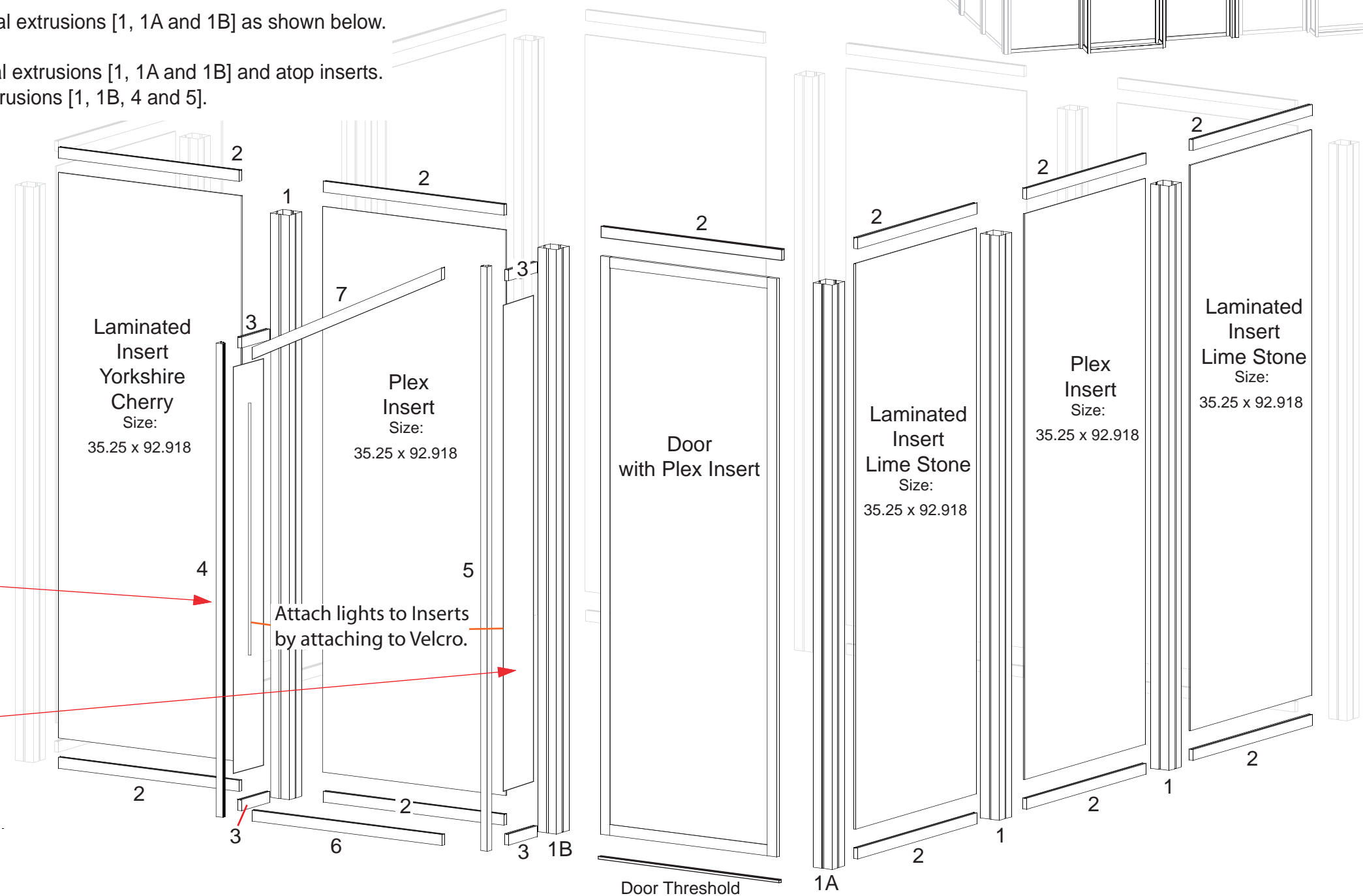
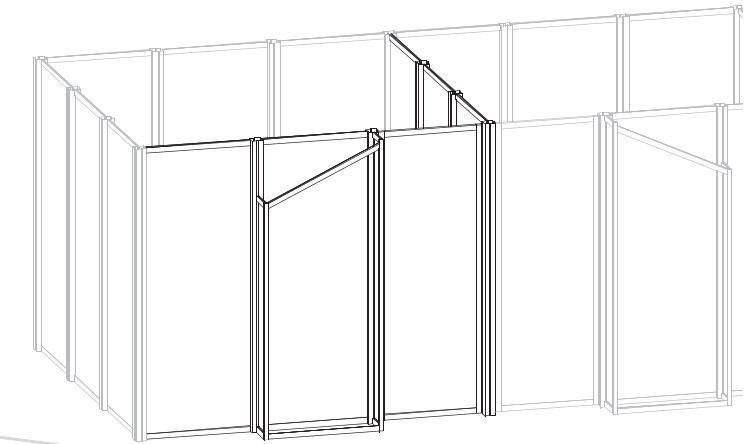

WHEN DISASSEMBLING ALUMINUM EXTRUSION, TIGHTEN ALL SETSCREWS AND LOCKS TO PREVENT LOSS DURING SHIPPING

866.652.2100

Part Number	Qty for Step	Description
1	7	96"h Vertical Extrusion
2	12	34.75" Horizontal Extrusion

Steps

- 1) Attach lower horizontal extrusions [2] between vertical extrusions [1] as shown below.
- 2) Place inserts as indicated.
- 3) Attach upper horizontal extrusions [2] between vertical extrusions [1] and atop inserts.

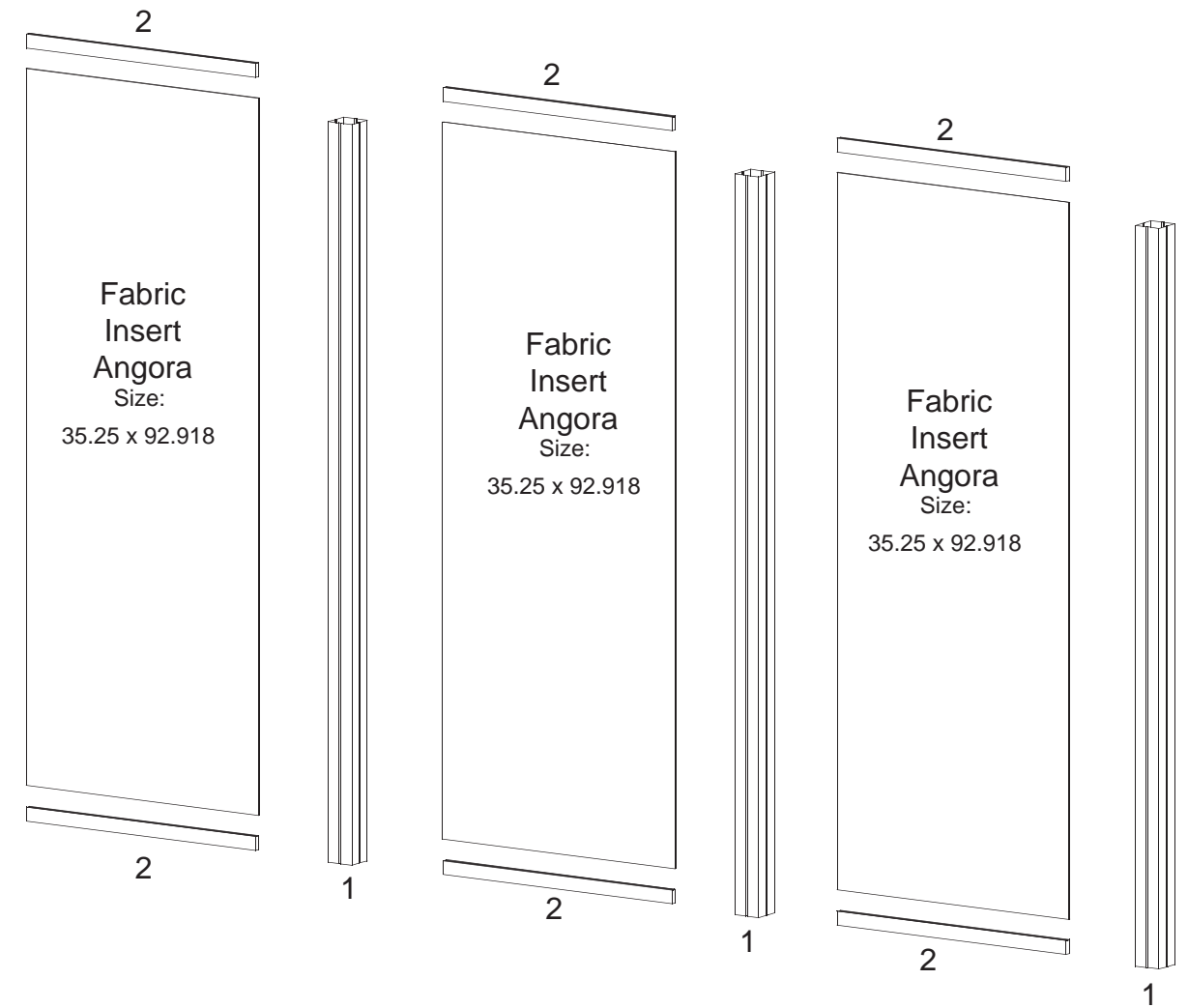
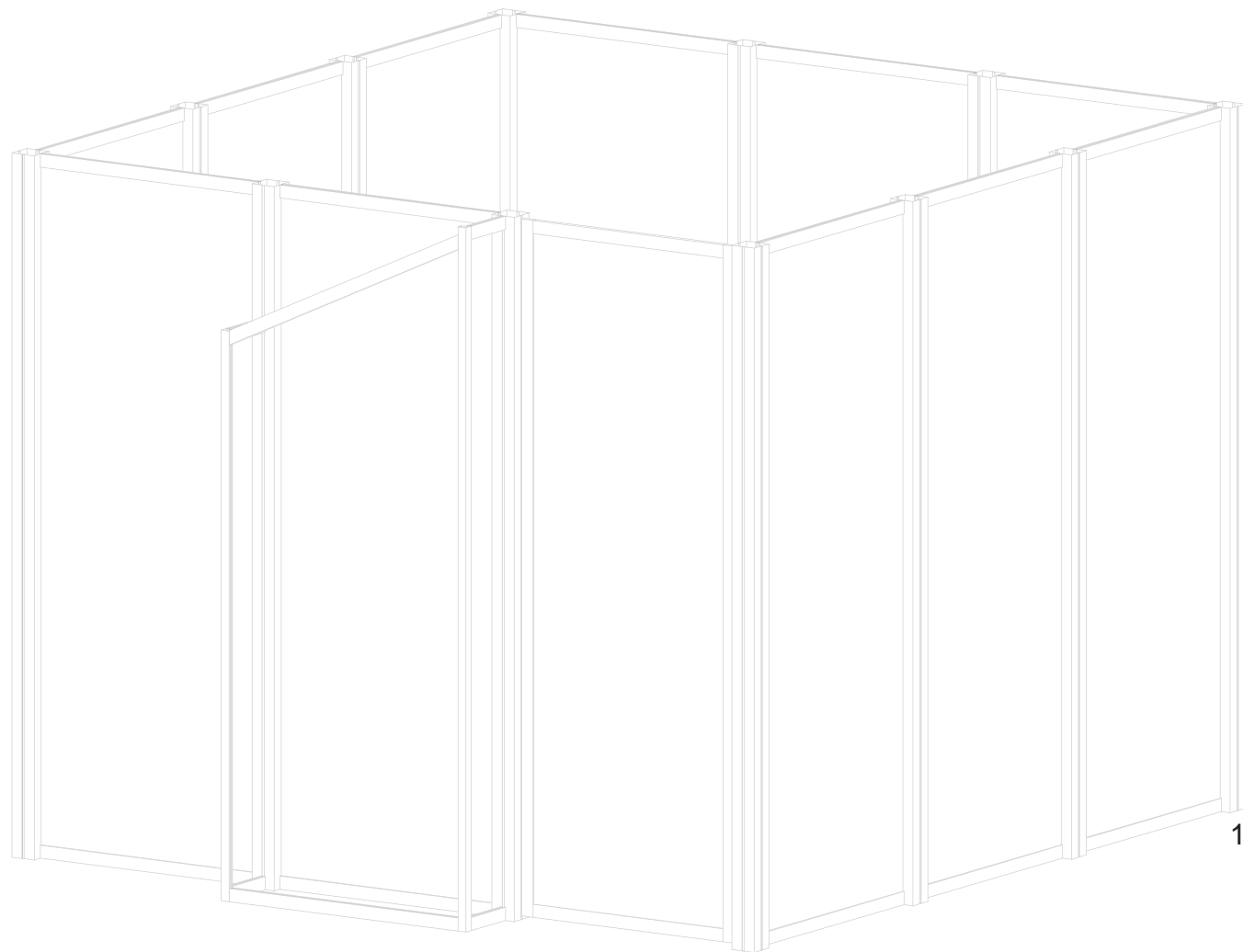
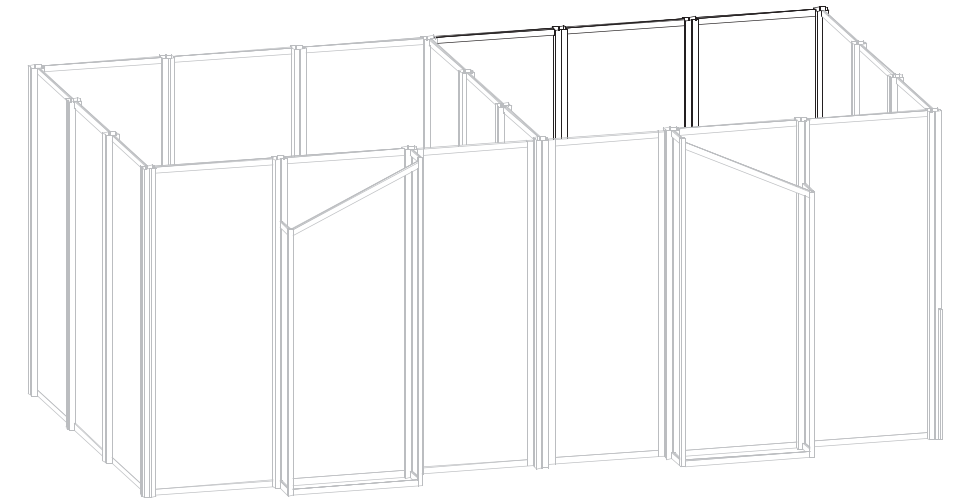

WHEN DISASSEMBLING ALUMINUM EXTRUSION, TIGHTEN ALL SETSCREWS AND LOCKS TO PREVENT LOSS DURING SHIPPING

866.652.2100

Part Number	Qty for Step	Description
1	3	96" Vertical Extrusion
1C	1	96" Vertical Extrusion w/ Door Hardware
2	11	34.75" Horizontal Extrusion
3	4	12" Horizontal Extrusion
6	1	36.541" Horizontal Extrusion
8	1	96" Vertical Extrusion w/ Attached Endcap
9	1	96" 90° Vertical Extrusion Tapered at Top
10	1	77.776" 90° Vertical Extrusion Tapered at Top
11	1	40.319" Horizontal Extrusion Tapered at Both Ends

Steps

- 1) Attach lower horizontal extrusions [2] between vertical extrusions [1, 8 and 1C] as shown below.
- 2) Place inserts and Door as indicated.
- 3) Attach upper horizontal extrusions [2] between vertical extrusions [1, 8 and 1C] and atop inserts.
- 4) Attach lower extrusions [3 and 6] between vertical extrusions [1, 1C, 9 and 10].
- 5) Place inserts as indicated.
- 6) Connect upper horizontal extrusions [3] between vertical extrusions [1, 1C, 9 and 10] and atop inserts.
- 7) Connect tapered extrusion [11] between verticals [9 and 10] making sure it is flush with top of extrusions.
- 8) Apply Graphics to Velcro on Backside of verticals [6, 9, 10 and 11].

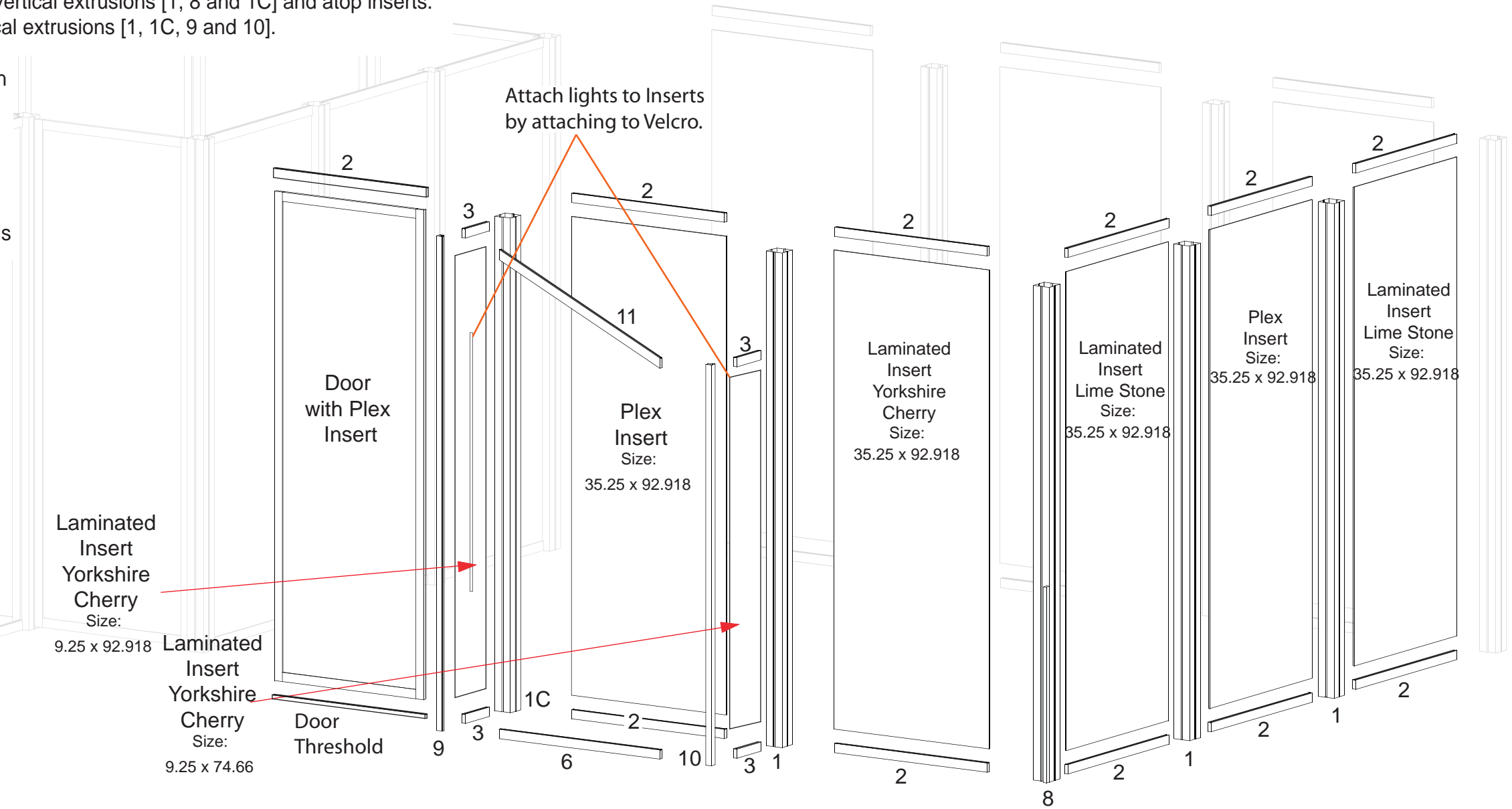
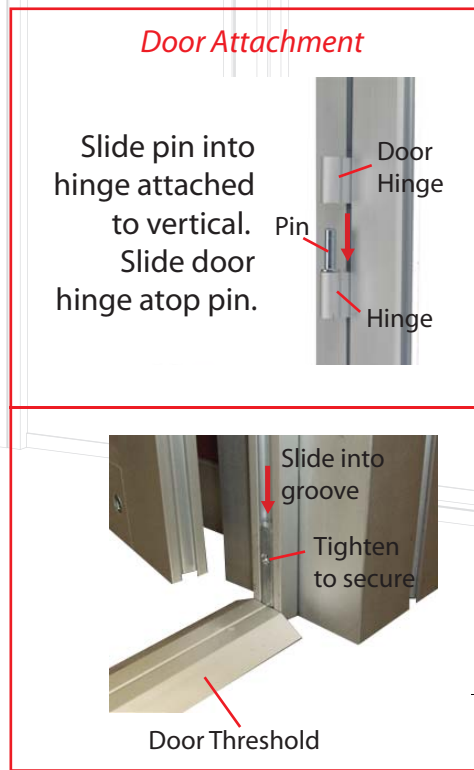
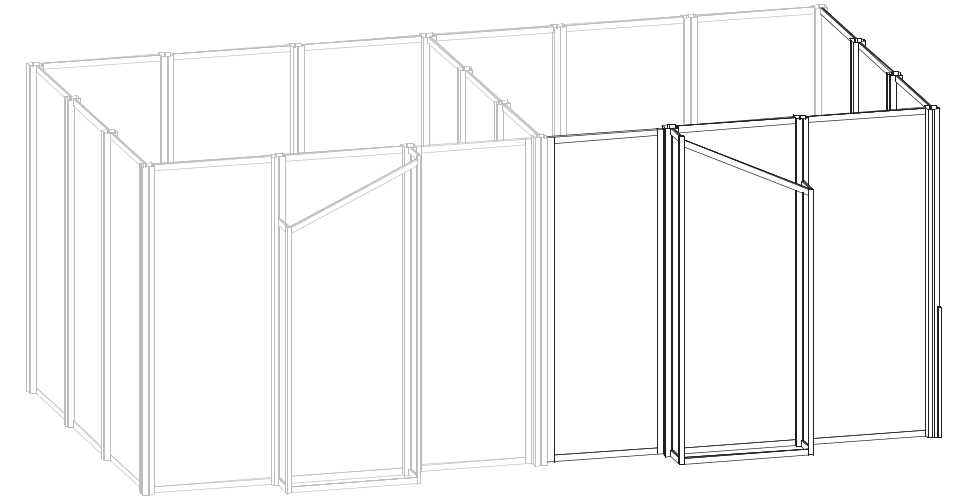

WHEN DISASSEMBLING ALUMINUM EXTRUSION, TIGHTEN ALL SETSCREWS AND LOCKS TO PREVENT LOSS DURING SHIPPING

Item Number	Description
130	23" x 42" Flat Panel
131	42" 90° Connector
132	23" x 42" Flat Panel
133	42" 45° Connector
134	32.944" x 42" Door Panel
135	42" 45° Connector
136	23" x 42" Flat Panel
137	42" 45° Connector
138	32.944" x 42" Door Panel
139	42" 45° Connector
140	23" x 42" Flat Panel
141	42" 90° Connector

Assemble Panels in order starting with #130* as shown in illustration.

Place internal shelf into assembled pedestal atop Velcroed Counter supports.

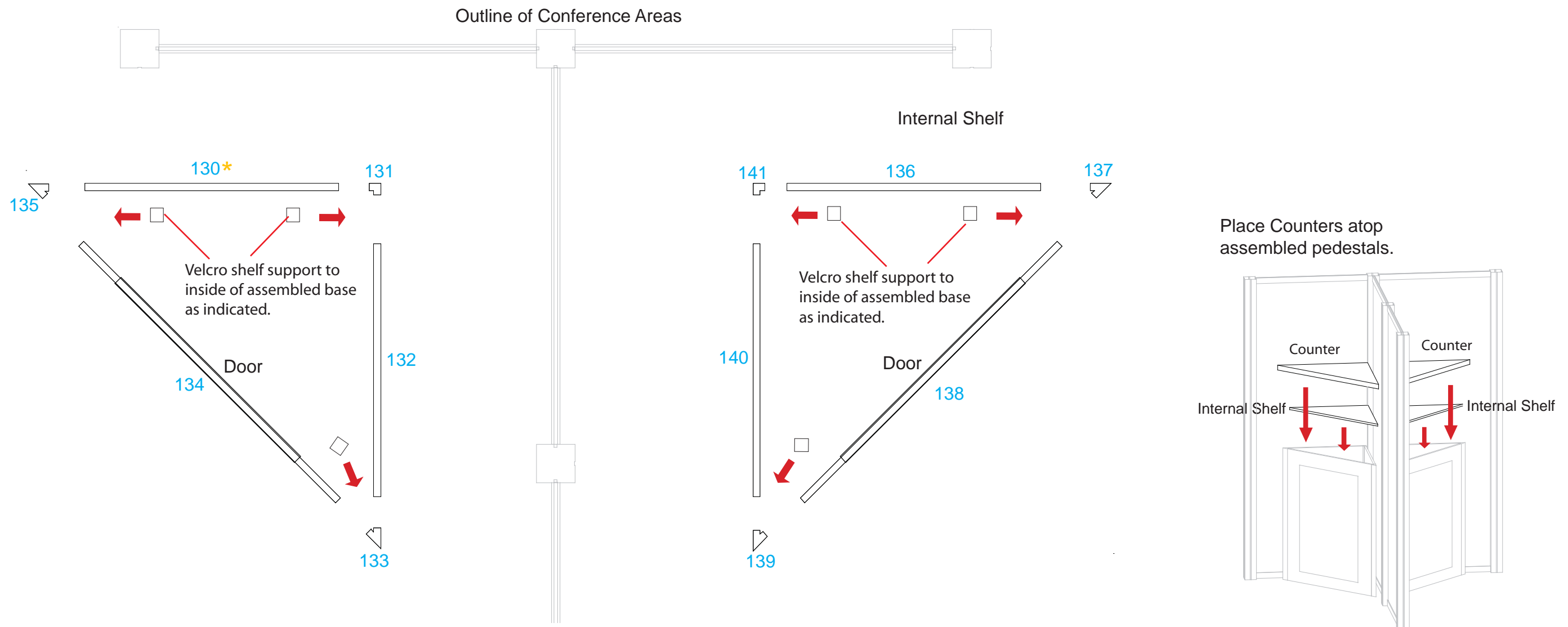

WHEN DISASSEMBLING ALUMINUM EXTRUSION, TIGHTEN ALL SETSCREWS AND LOCKS TO PREVENT LOSS DURING SHIPPING

866.652.2100

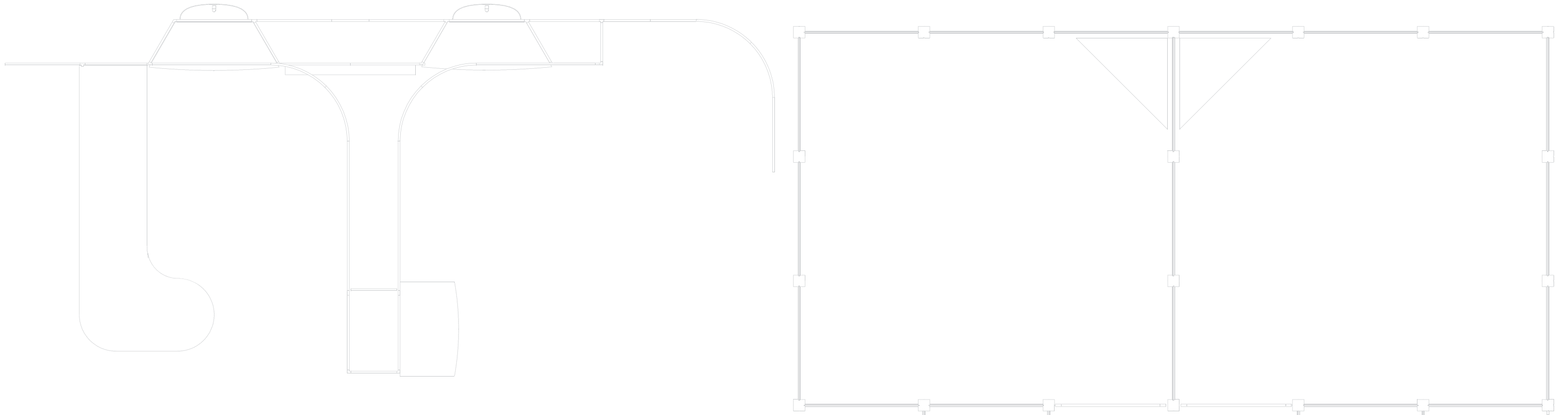

- | Item Number | Description |
|-------------|-------------------------|
| 48 | 19" x 38" Window Panel |
| 49 | 19" x 38" Window Panel |
| 50 | 19" x 38" Window Panel |
| 51 | 19" x 38" Graphic Panel |
| 52 | 38" 90 Degree Connector |
| 53 | 19" x 38" Grpahic Panel |
| 54 | 19" x 38" Window Panel |
| 55 | 19" x 38" Window Panel |
| 56 | 19" x 38" Window Panel |
| 58 | 19" x 38" Window Panel |

- | Item Number | Description |
|-------------|--------------------------|
| 67 | 38" T-Connector |
| 68 | 23" x 38" Flat Panel |
| 69 | 38" T-Connector |
| 70 | 14.125" x 38" Flat Panel |
| 71 | 38" 90° Connector |
| 72 | 23" x 38" Flat Panel |
| 73 | 38" 90° Connector |
| 74 | 14.125" x 38" Flat Panel |
| 75 | 19" x 38" Window Panel |
| 76 | 19" x 38" Window Panel |
| 77 | 19" x 38" Window Panel |
| 79 | 19" x 38" Window Panel |
| 80 | 38" Tapered Panel |
| 81 | 38" Tapered Panel |

Place decorative cap [A, B, C and D] on top of assembled wall as shown. Then place Counters atop assembled Pedestals.

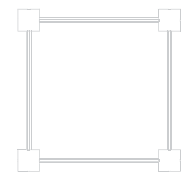
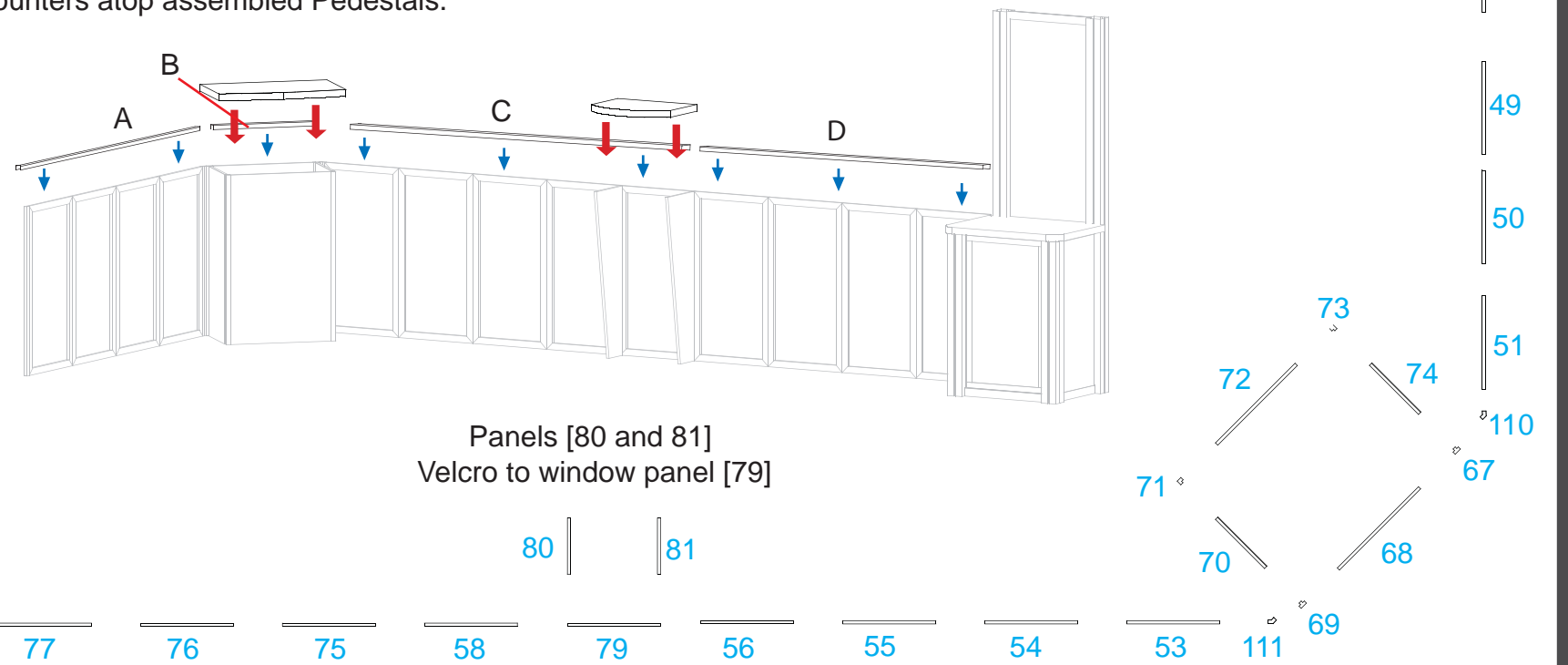

- | | |
|-----|--------------------|
| 110 | 38" 135° Connector |
| 111 | 38" 135° Connector |



WHEN DISASSEMBLING ALUMINUM EXTRUSION, TIGHTEN ALL SETSCREWS AND LOCKS TO PREVENT LOSS DURING SHIPPING

Part Number	Qty for Step	Description
13	1	84"h Vertical Extrusion
13A	1	38"h Vertical Extrusion w/ Door Stop
13B	1	38"h Vertical Extrusion w/ Door Hinges
13C	1	84"h Vertical Extrusion w/ Attached Endcap
14	4	20.5" Horizontal Extrusion
15	4	16" Horizontal Extrusion

Steps

- 1) Attach lower horizontal extrusions [14 and 15] between vertical extrusions [13, 13A, 13B and 13C] as shown below.
- 2) Place large insert and attach upper horizontal [14] between vertical extrusions [13 and 13C] and atop insert.
- 3) Place smaller inserts and door as indicated below.
- 4) Attach upper horizontals [14 and 15] between verticals [13, 13A, 13B and 13C] and atop inserts and door as shown.
- 5) Place Counter atop assembled pedestal.

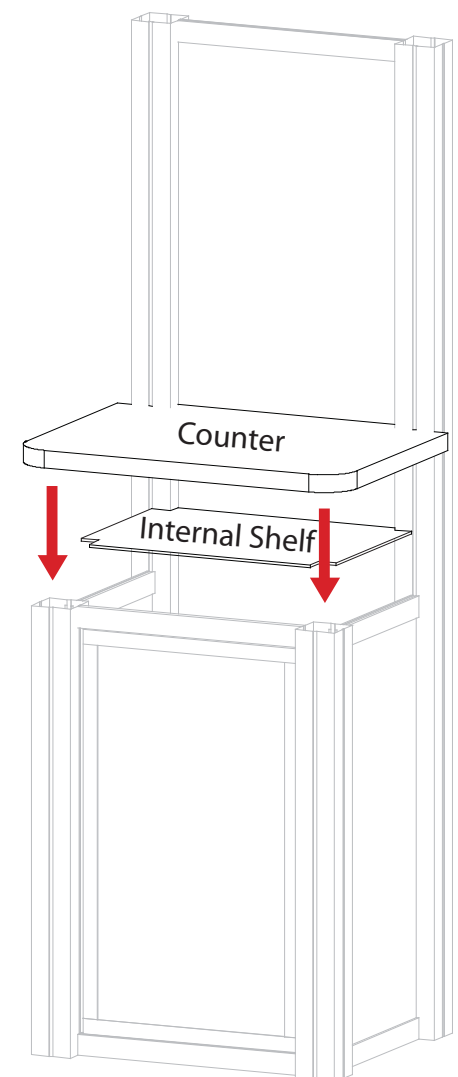
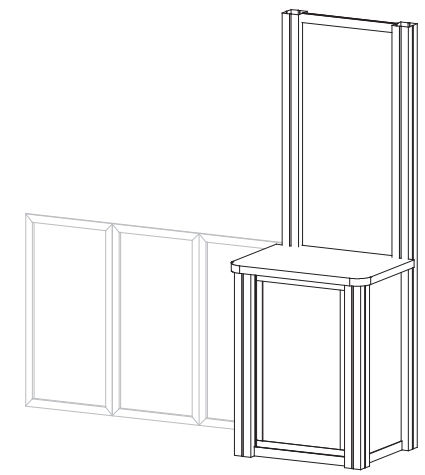
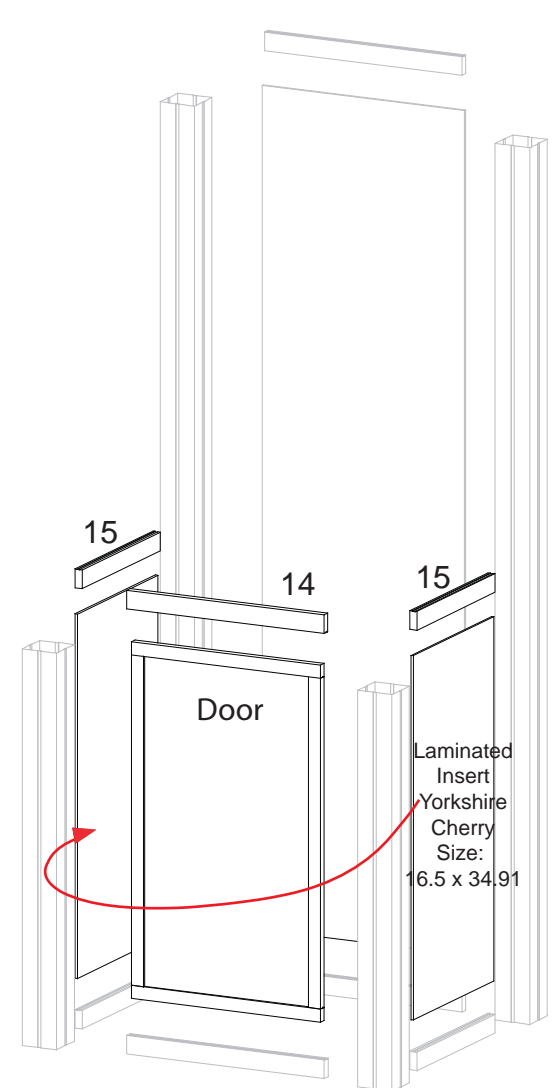
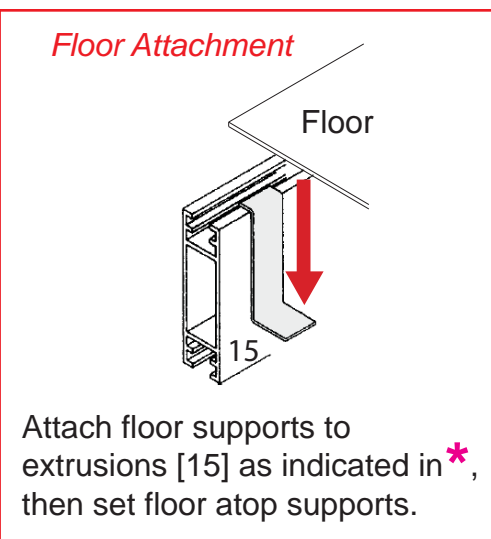
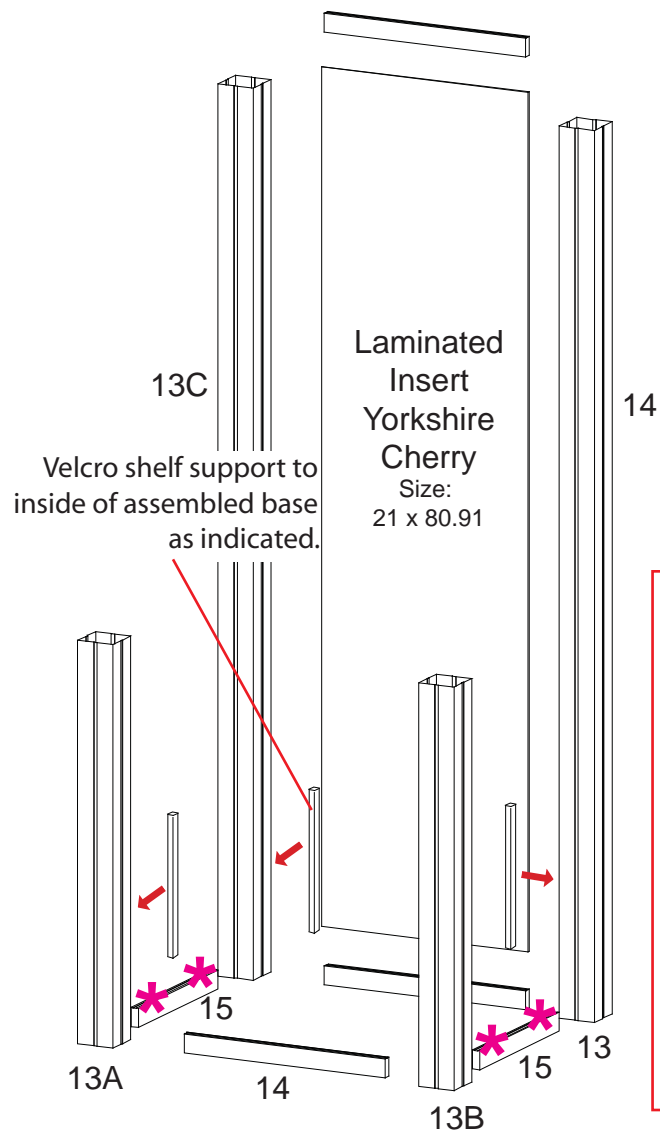

866.652.2100

Wire Cover Attachment

Slide cover into groove of extrusion.

Slide cover into groove of extrusions

Wire Cover

Wire Cover

WHEN DISASSEMBLING ALUMINUM EXTRUSION, TIGHTEN ALL SETSCREWS AND LOCKS TO PREVENT LOSS DURING SHIPPING

866.652.2100

Part Number	Qty for Step	Description
16	4	96" Vertical Extrusion w/ Slideable Connectors Attached
17	4	19.5" Horizontal Extrusion
18	4	19.5" Horizontal Extrusion

Steps

- 1) Attach lower horizontal extrusions [17] between vertical extrusions [16] as shown below.
Note: Slide connector UP to allow horizontal bar to attach to vertical post.
- 2) Attach upper horizontal extrusions [18] between vertical extrusions [16].
- 3) Attach Graphics.

Velcro facing outside of tower.

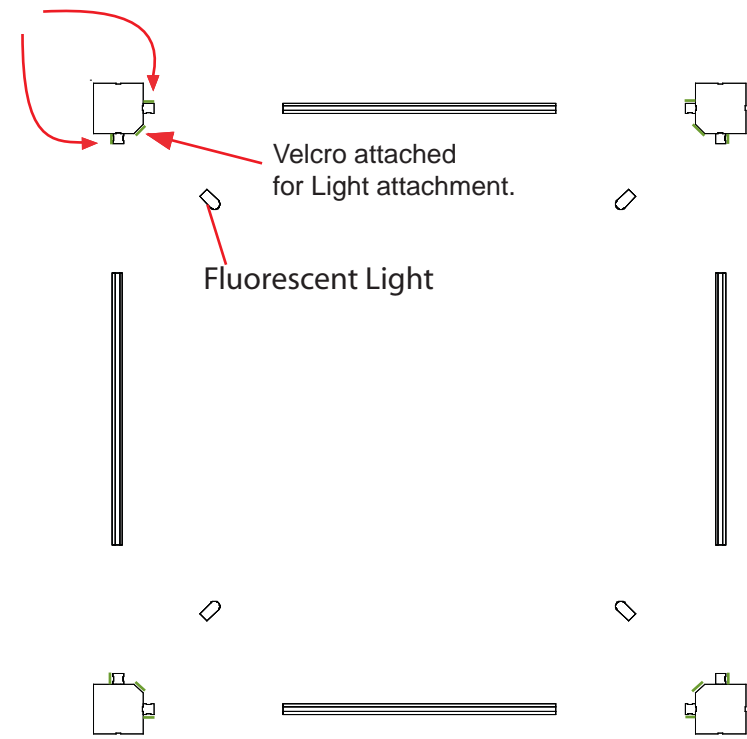

Plan View

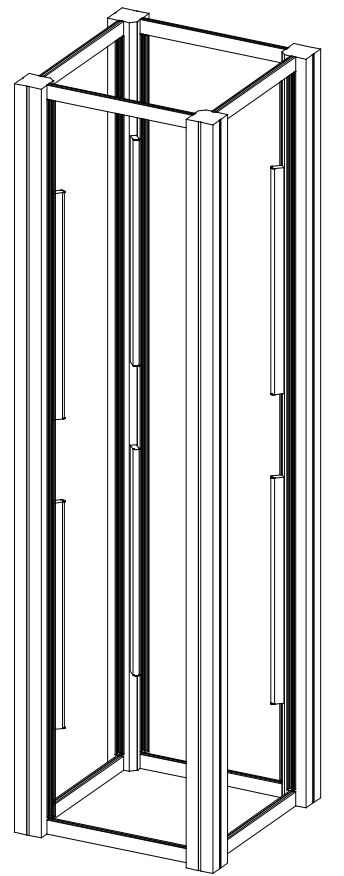
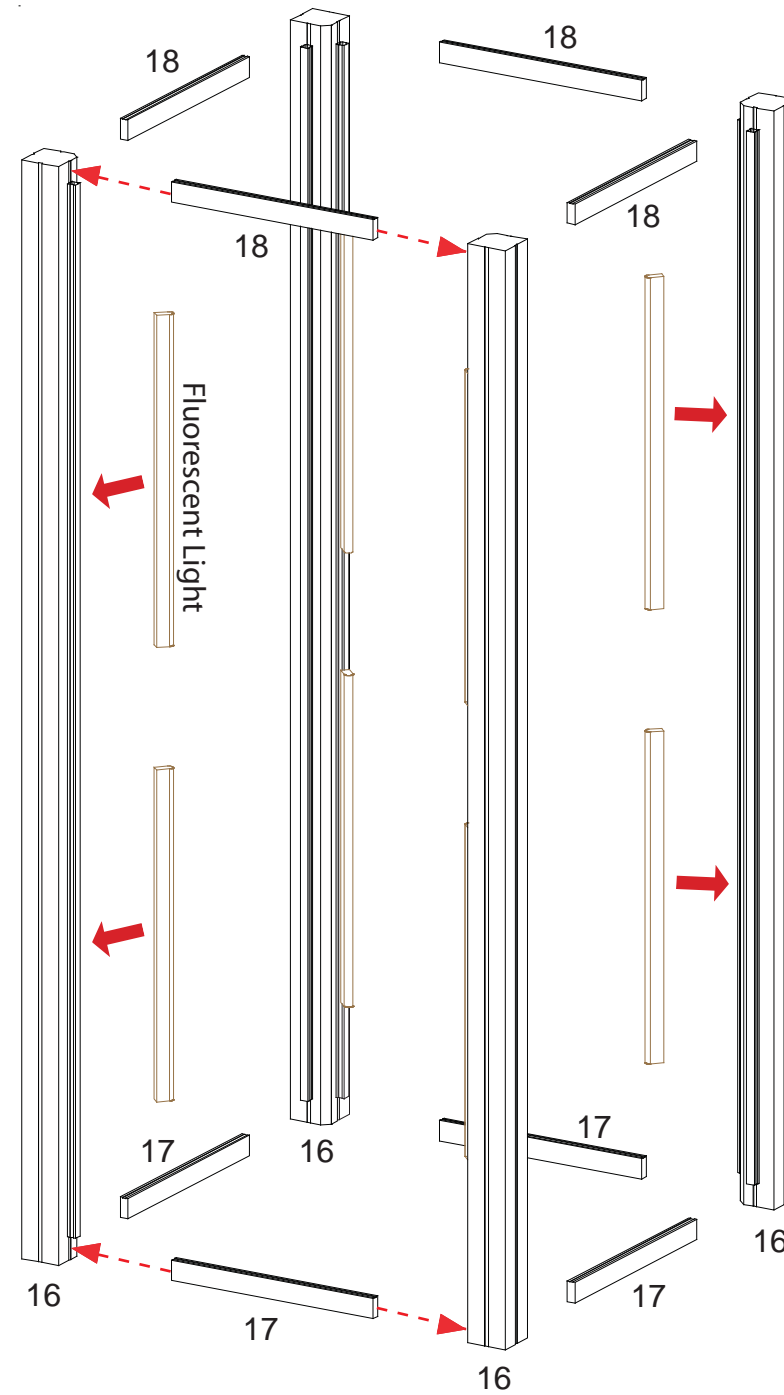

WHEN DISASSEMBLING ALUMINUM EXTRUSION, TIGHTEN ALL SETSCREWS AND LOCKS TO PREVENT LOSS DURING SHIPPING

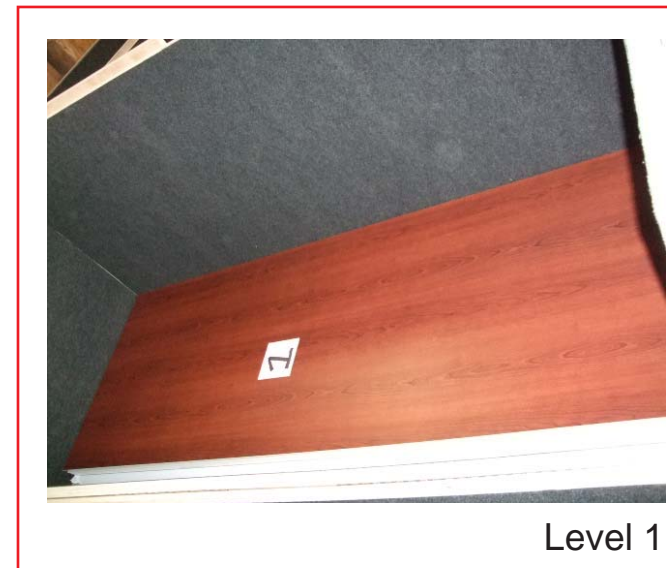
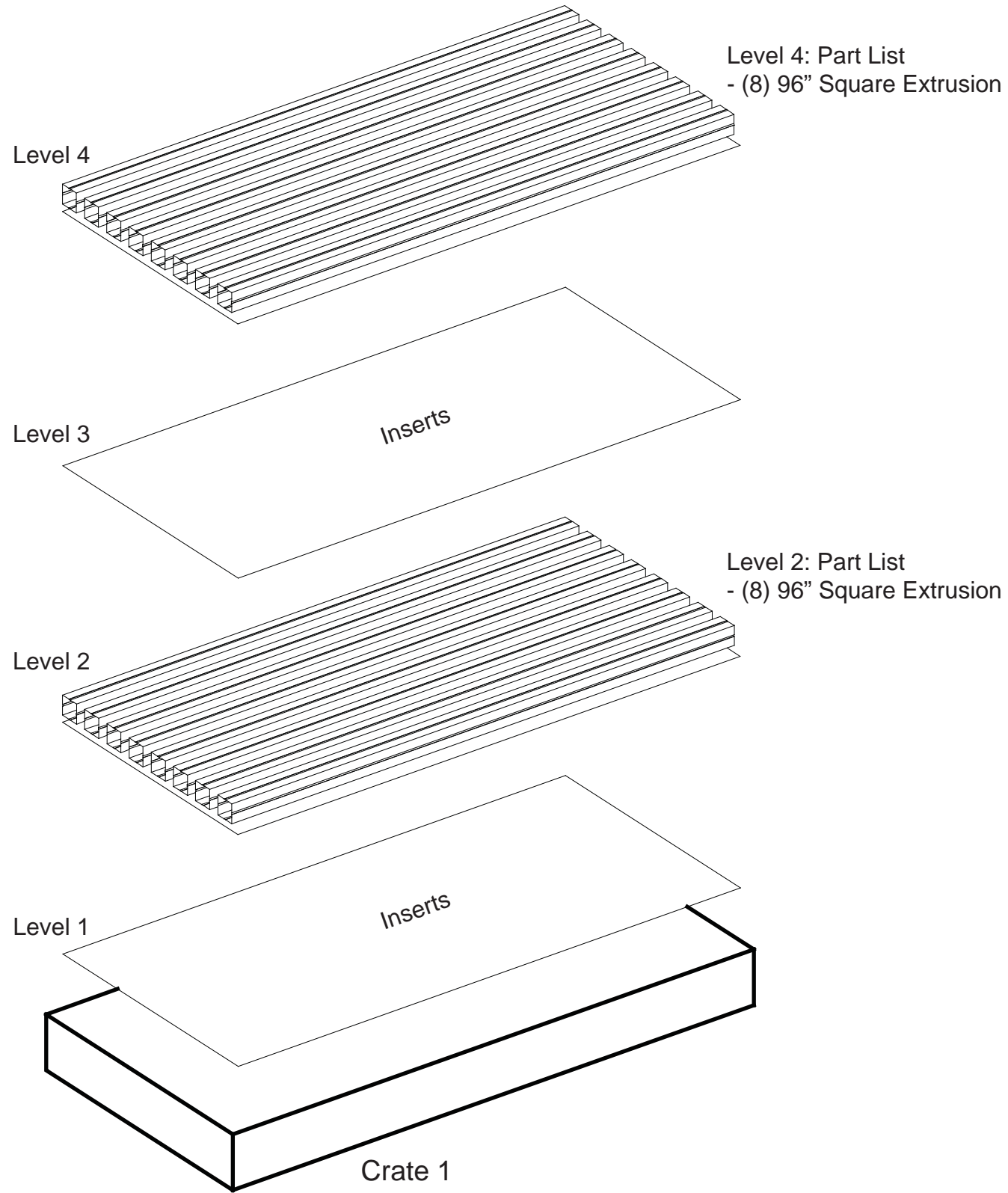

WHEN DISASSEMBLING ALUMINUM EXTRUSION, TIGHTEN ALL SETSCREWS AND LOCKS TO PREVENT LOSS DURING SHIPPING

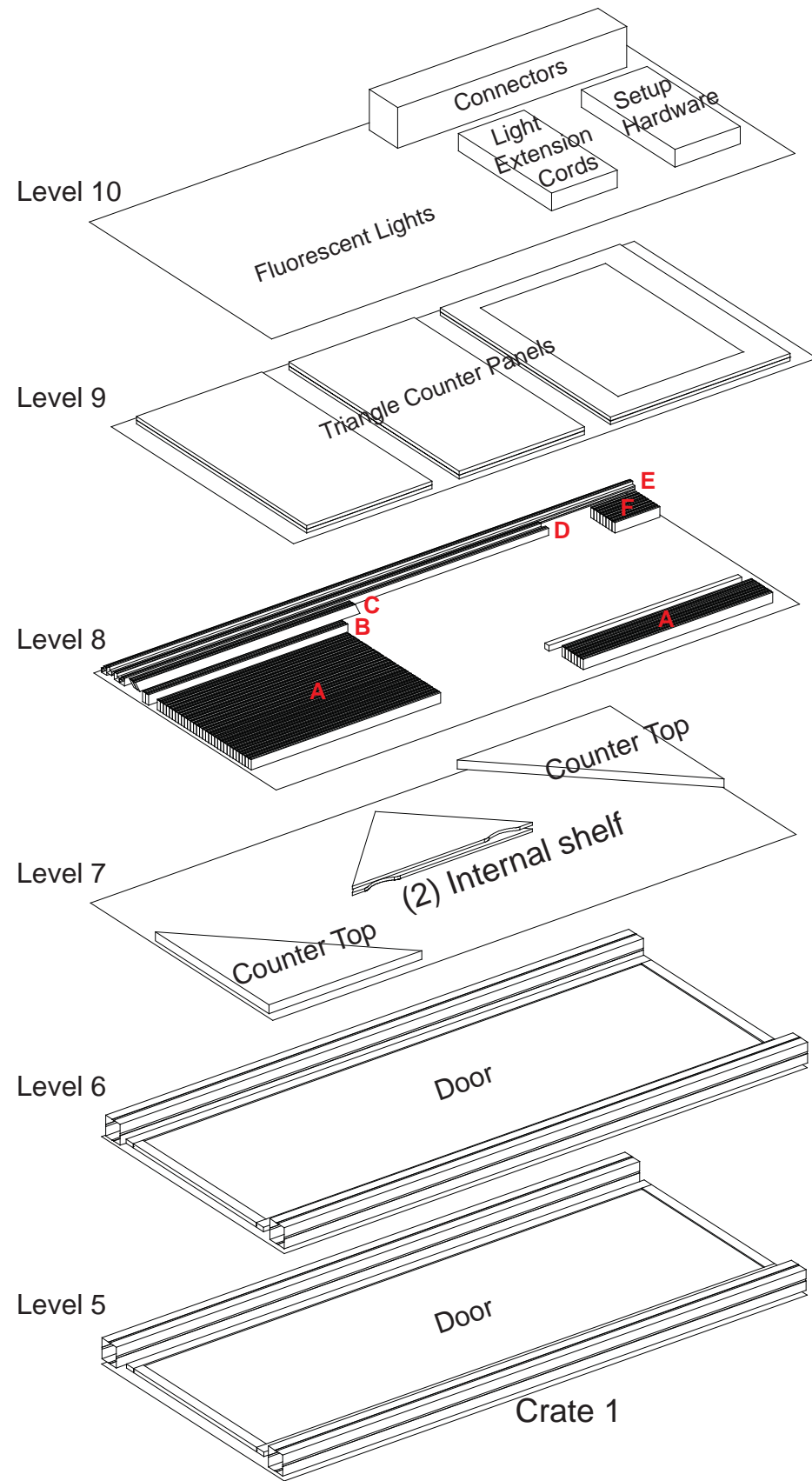

- Level 8: Part List
 A - (38) 34.75" Extrusion
 - (1) Door Threshold
 B - (2) 36.54" Extrusion
 C - (2) 41.3" Extrusion
 D - (2) 77.77" Extrusion
 E - (2) 96" Extrusion
 F - (8) 8.25" Extrusion

- Level 6: Part List
 - (2) 96" Square Extrusion
 - (1) Door

- Level 5: Part List
 - (2) 96" Square Extrusion
 - (1) Door



Level 9



Level 10



Level 8



Level 7



Level 6



Level 5

WHEN DISASSEMBLING ALUMINUM EXTRUSION, TIGHTEN ALL SETSCREWS AND LOCKS TO PREVENT LOSS DURING SHIPPING

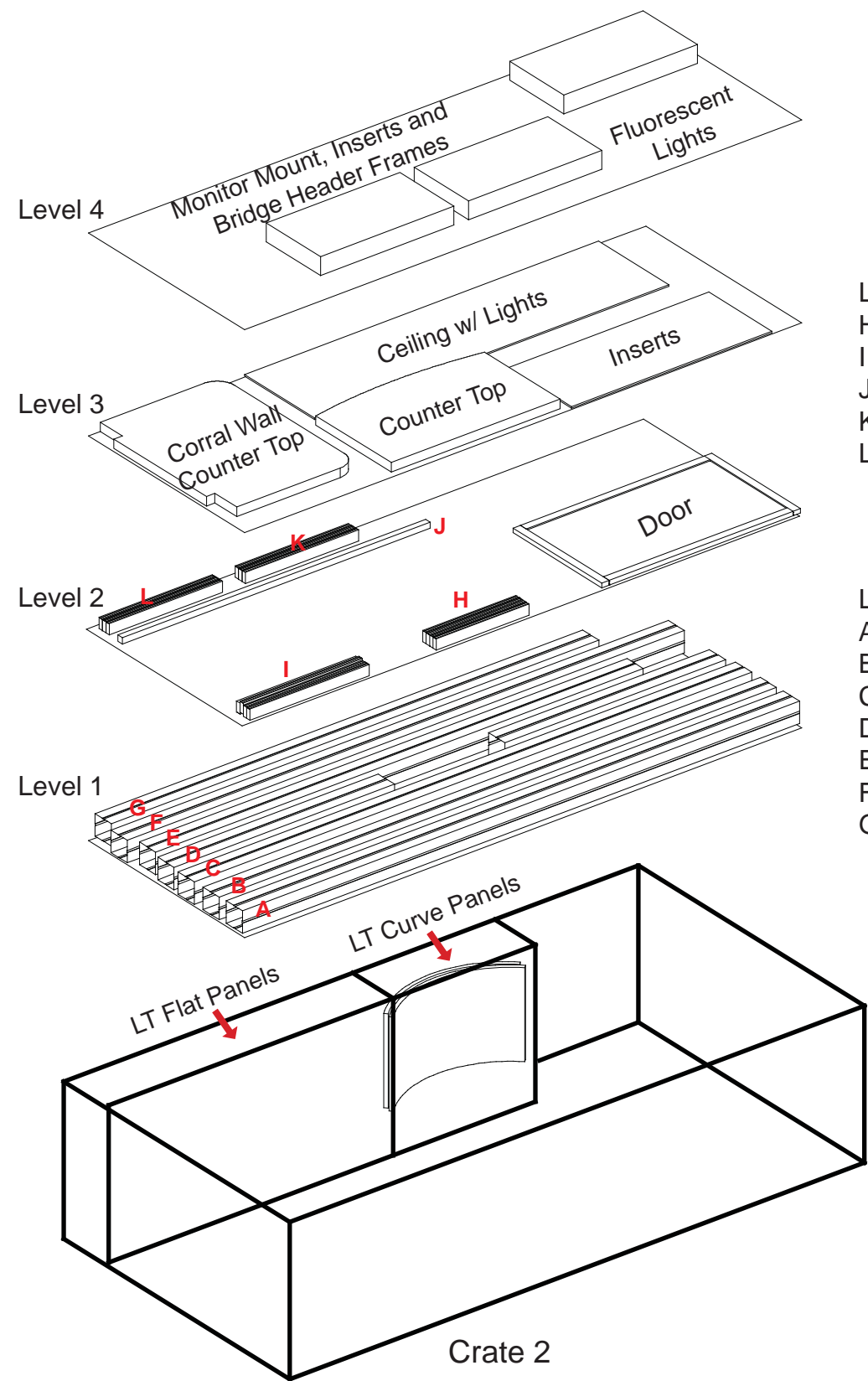

- Level 2: Part List
 H - (4) 16" Extrusion
 I - (4) 20.5" Extrusion
 J - Light Support Bar
 K - (3) 19.5" Extrusion
 L - (3) 19.5" Extrusion

- Level 1: Part List
 A - (1) 96" Extrusion
 B - (1) 96" Extrusion
 C - (1) 96" Extrusion
 D - (2) 38" Extrusion
 E - (1) 96" Extrusion
 F - (1) 84" Extrusion
 G - (1) 96" Extrusion



Setup Hardware Boxes



Level 4



Level 3



Level 2



Level 1

WHEN DISASSEMBLING ALUMINUM EXTRUSION, TIGHTEN ALL SETSCREWS AND LOCKS TO PREVENT LOSS DURING SHIPPING