

Perfect 10 Hybrid Displays

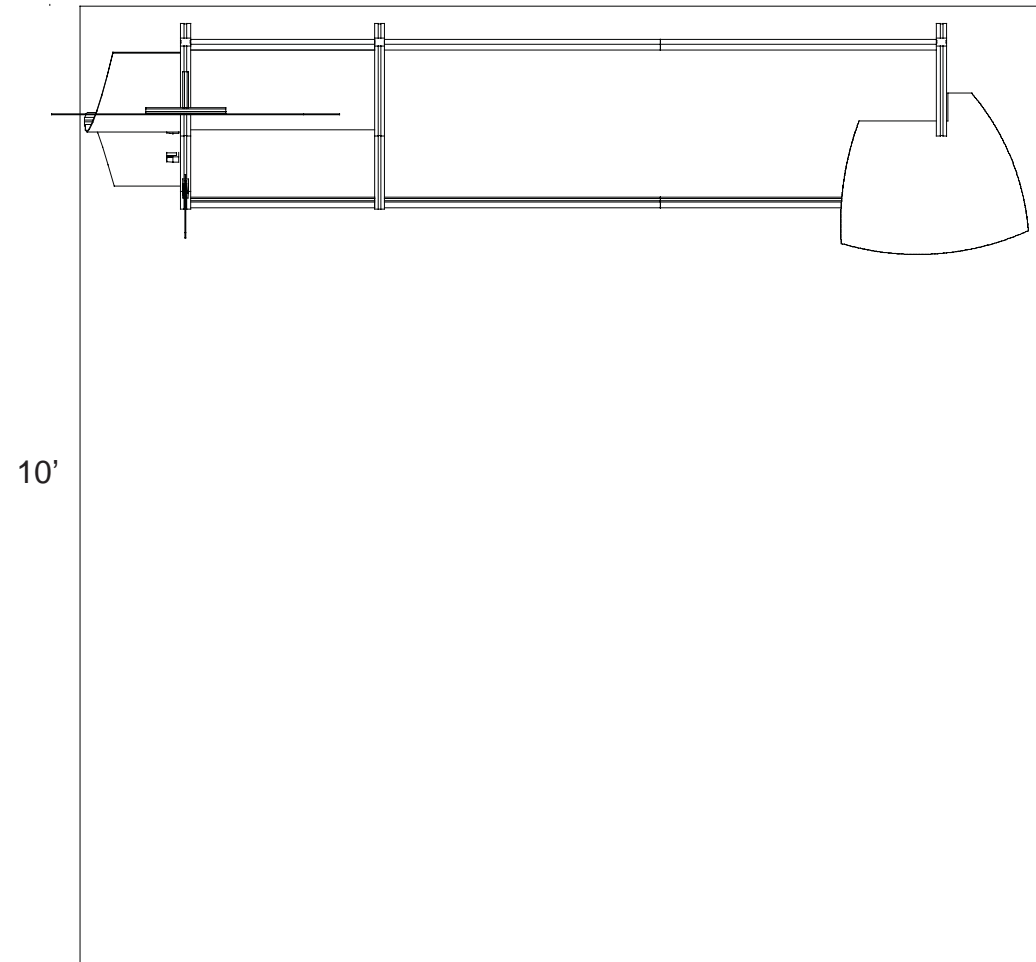

10'

Plan View

10'

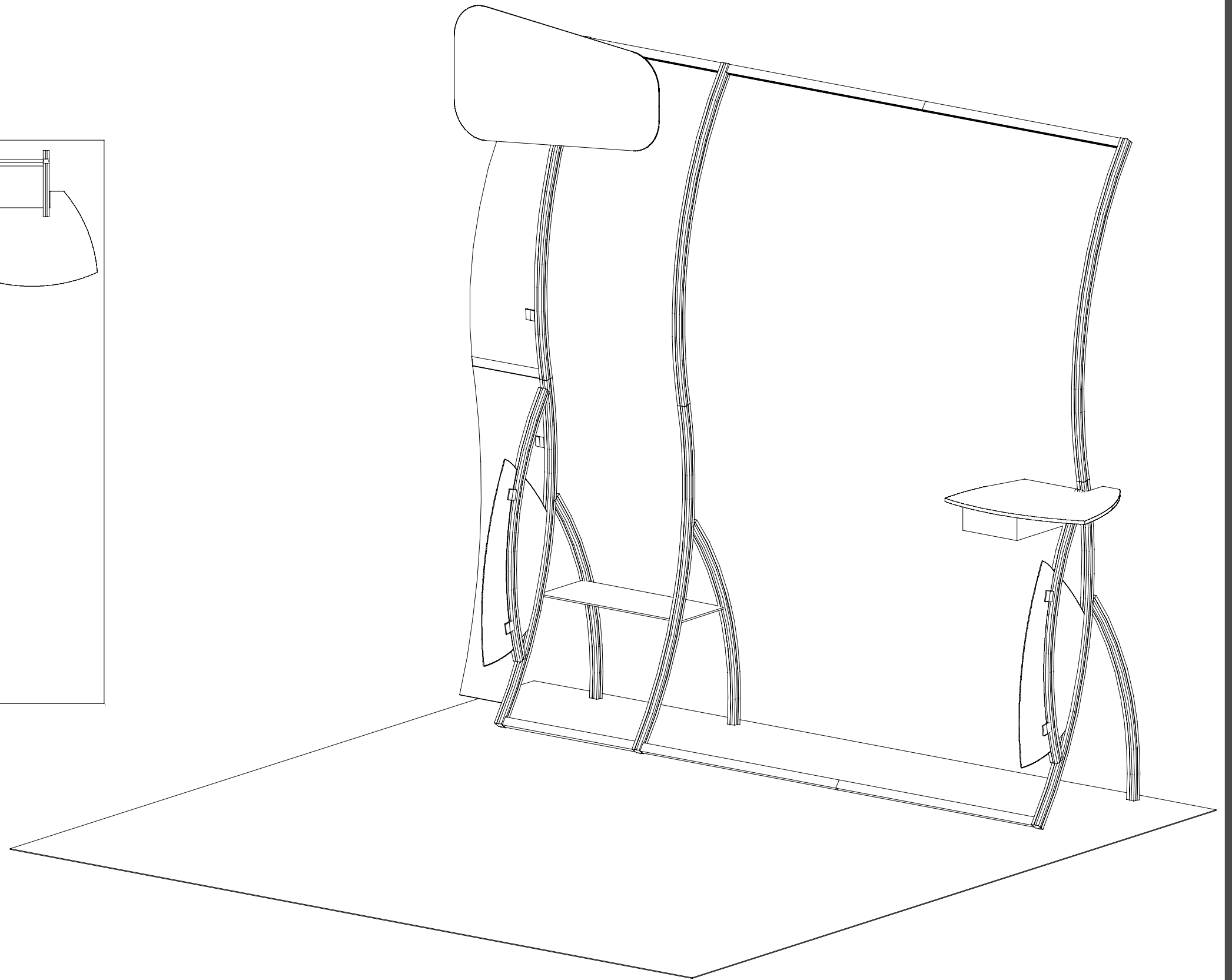

WHEN DISASSEMBLING ALUMINUM EXTRUSION, TIGHTEN ALL SETSCREWS AND LOCKS TO PREVENT LOSS DURING SHIPPING

866.652.2100

Part Number	Description
1	Left Leg Assembly w/ A10 Clamps Attached
2	Middle Leg Assembly
3A	Upper Curved Vertical w/ A10 Clamps Attached
3	Upper Curved Vertical
4	23" w Horizontal
5	Right Leg Assembly
6	Upper Curved Vertical
7	69" w Horizontal w/ Hinge Facing UP
8	69" w Horizontal w/ Hinge Facing DOWN

NOTE: When assembling horizontals they should be placed approximately one inch from TOP and BOTTOM.

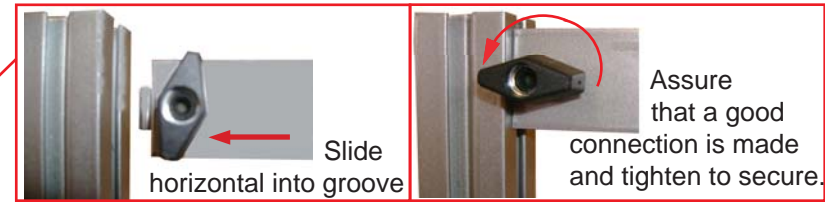

Steps:

NOTE: Assembly may be easiest if assembled face down on floor then lifted upright.

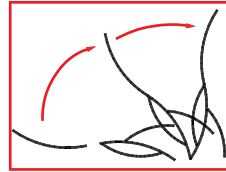

- 1) Connect vertical extrusions [3 and 3A] to leg assemblies [1 and 2] using vertical connection bar as shown.
- 2) Connect horizontal extrusions [4] between vertical assemblies by slightly tightening BLACK knobs on backside of extrusion making sure Velcro faces toward BACK.
- 3) Connect vertical extrusion [6] to leg assembly [5] using vertical connection bar as shown.
- 4) Connect horizontal extrusions [4] between vertical assemblies by slightly tightening BLACK knobs on backside of extrusion making sure Velcro faces toward BACK.

NOTE: Make sure the lock is flush to groove in extrusion before tightening, to avoid the extrusion from popping out.

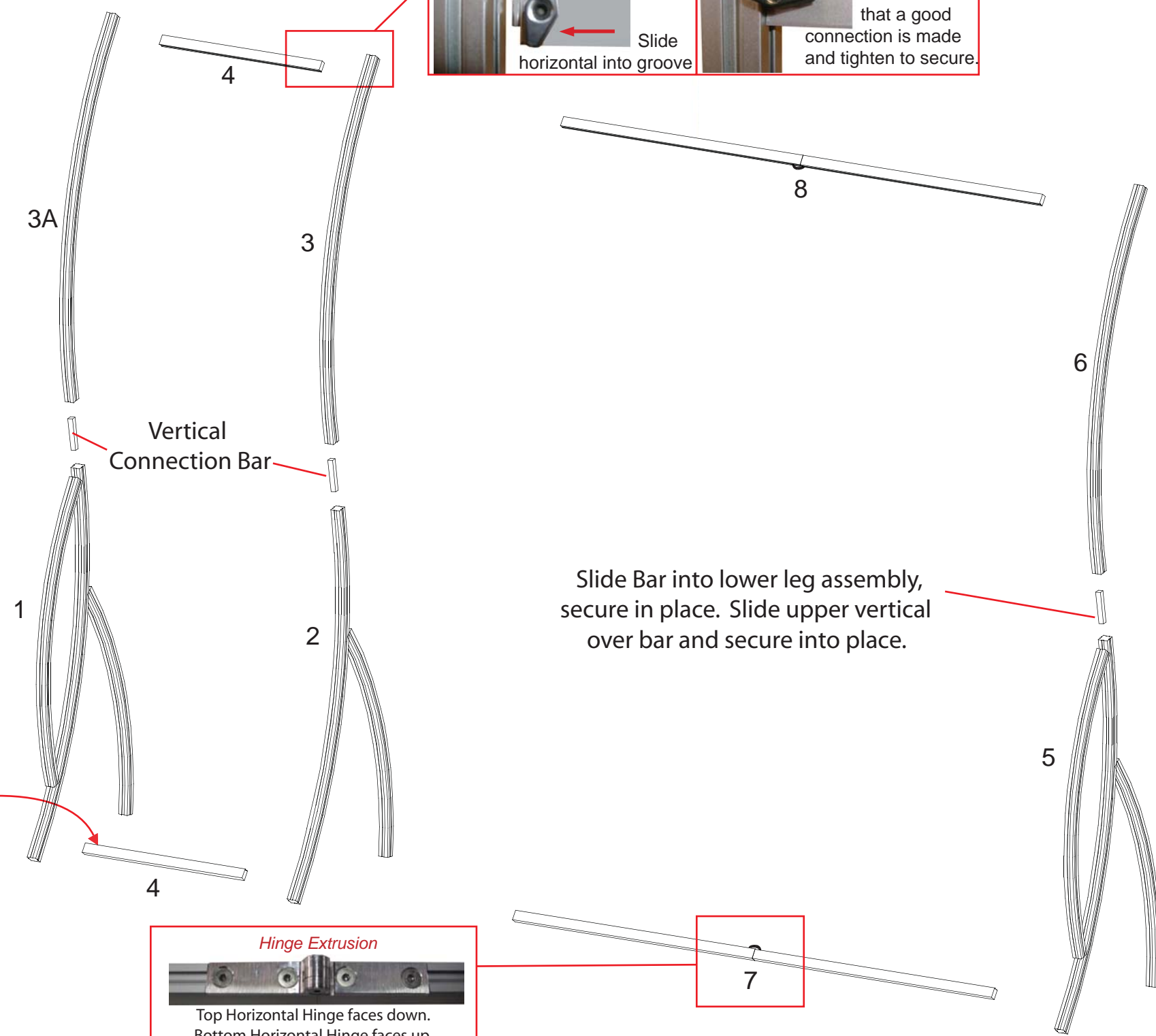

Slide Bar into lower leg assembly, secure in place. Slide upper vertical over bar and secure into place.

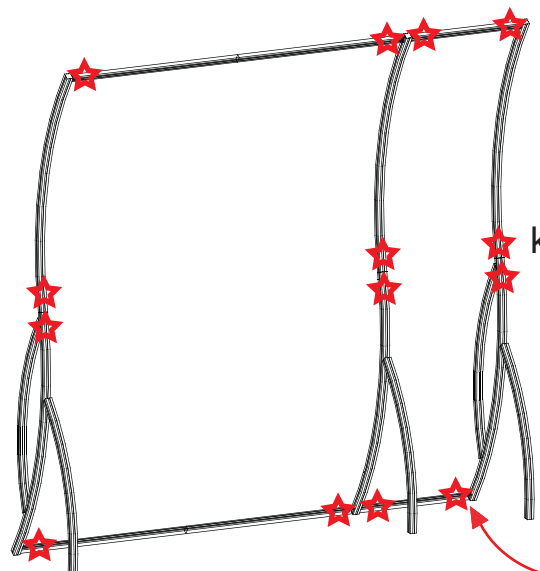

STAR indicates location of knobs on BACKSIDE of unit.

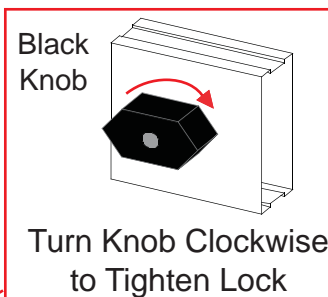

WHEN DISASSEMBLING ALUMINUM EXTRUSION, TIGHTEN ALL SETSCREWS AND LOCKS TO PREVENT LOSS DURING SHIPPING

866.652.2100

Header Attachment -
Attach Header support to Backwall then attach header to velcro on support.

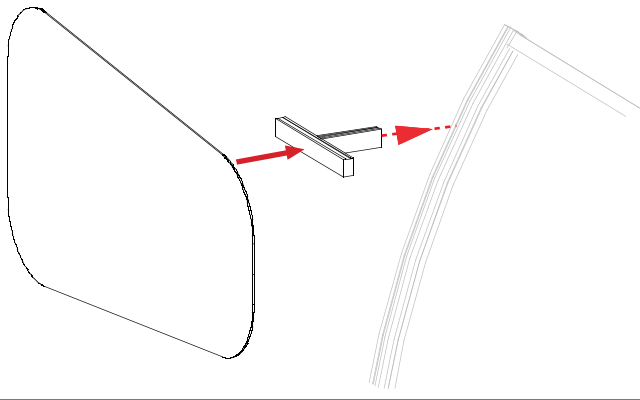

Light Connection
Attach Lights to Backwall where desired and tighten in place.

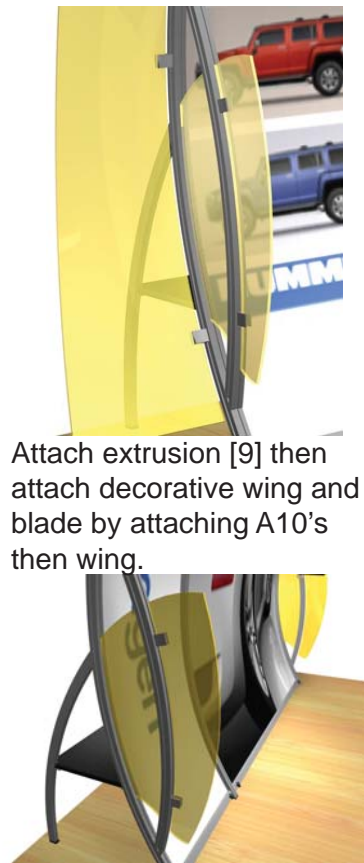
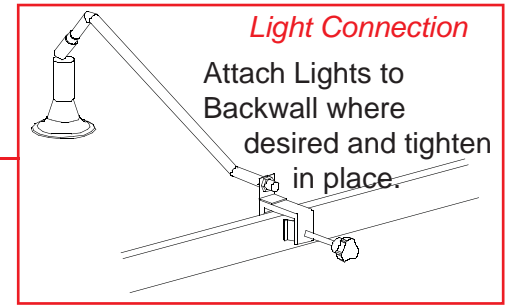

Attach extrusion [9] then attach decorative wing and blade by attaching A10's then wing.

Decorative Blade Attachment

Slide A10 Clamp into groove of square extrusion.

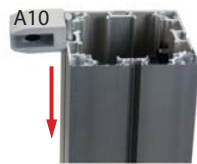

When desired location is found, tighten set screw to secure.

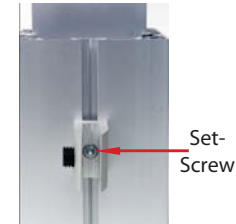

Tighten black plastic set screw to secure Wing in place.

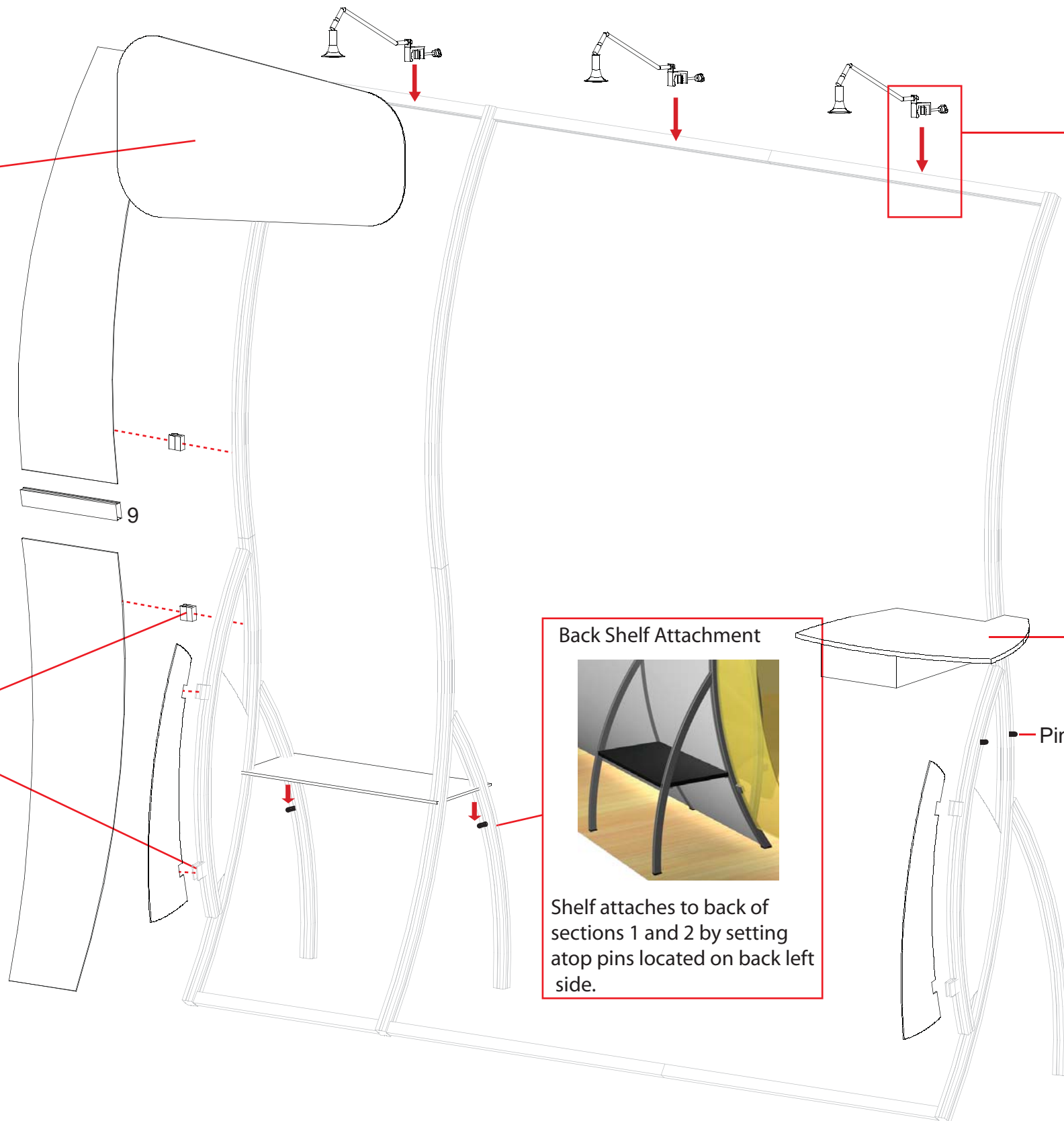

Back Shelf Attachment



Shelf attaches to back of sections 1 and 2 by setting atop pins located on back left side.

Cubby Attachment
Shelf attaches to section 5 by setting atop pins located on right side and securing into place with thumbscrew on left.

Slide onto back pin first.
When attaching counter you will need to first slide shelf onto back pin then set down on front pin.

WHEN DISASSEMBLING ALUMINUM EXTRUSION, TIGHTEN ALL SETSCREWS AND LOCKS TO PREVENT LOSS DURING SHIPPING