

WHEN DISASSEMBLING ALUMINUM EXTRUSION, TIGHTEN ALL SETSCREWS AND LOCKS TO PREVENT LOSS DURING SHIPPING

visionary™ IDESIGNS

Using Your Setup Instructions

The Visionary Designs Setup Instructions are created specifically for your configuration. They are laid out sequentially, including an exploded view of the entire display, and then a logical series of detailed steps to assemble the main structure and components. We encourage you to study the instructions **before** attempting to assemble your exhibit.

Each page reminds you to tighten the setscrews after disassembling your exhibit to prevent loss of the locks and setscrews (see below in RED). This is VERY IMPORTANT.

Cleaning and Packing Your Display

- 1) Use care when cleaning aluminum extrusion or acrylic inserts. Use only non-abrasive cleaners.
- 2) When cleaning laminate inserts or countertops, use mild cleansers and a soft material such as cotton.
- 3) Keep all display components away from extreme heat and long exposure to sunlight to avoid warping and fading.
- 4) Retain all packing material. It will make re-packing much easier and will reduce the likelihood of shipping damage.



The Tool

Most Visionary Designs exhibits can be assembled with the supplied Hex Key Tool. Occasionally, a flat head screwdriver may be required.



Typical Connection

Most horizontal extrusion connections have a patented expandable lock. This lock inserts into the groove of an opposing extrusion. Tightening the lock with the Hex Key Tool expands the lock and creates a strong positive connection.



Typical Connection (cont'd)

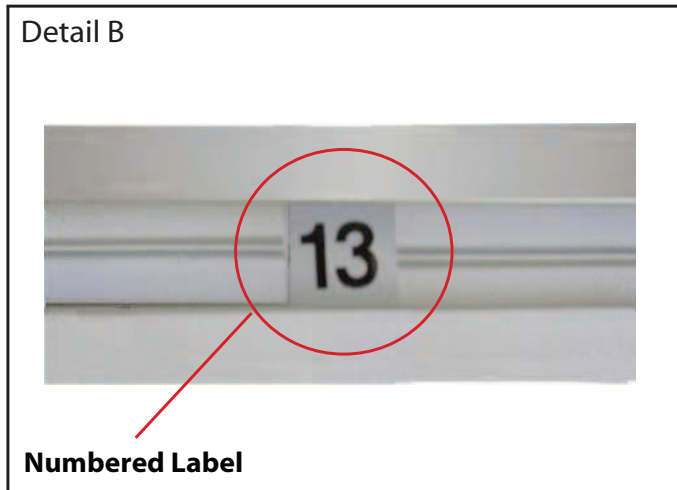

Detail B

Numbered Label

Each extrusion contains a numbered label which corresponds with setup instructions. The label is located within a groove of the extrusion (when possible). With Visionary Designs the labels contain Black numbers unless otherwise specified.



Detail C

Horizontal Inline Connection (remove only one setscrew)

Remove only (1) setscrew when disassembling. Replace setscrew in extrusion after assembling it. Before packing, replace setscrew in extrusion to avoid losing it.

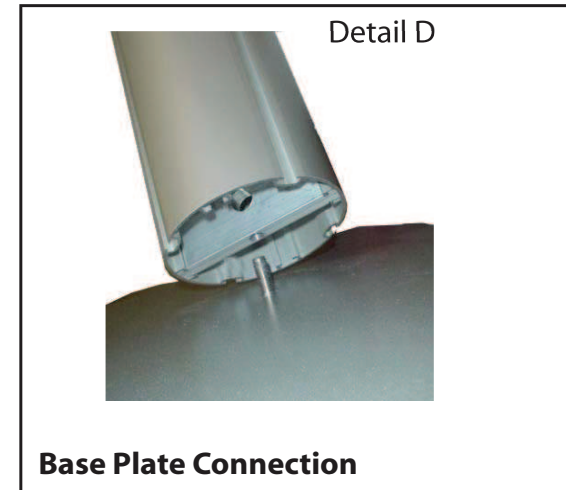

Detail D

Base Plate Connection

Attach base plate to round or square vertical extrusion using the bolt provided. Be careful not to strip the threads.

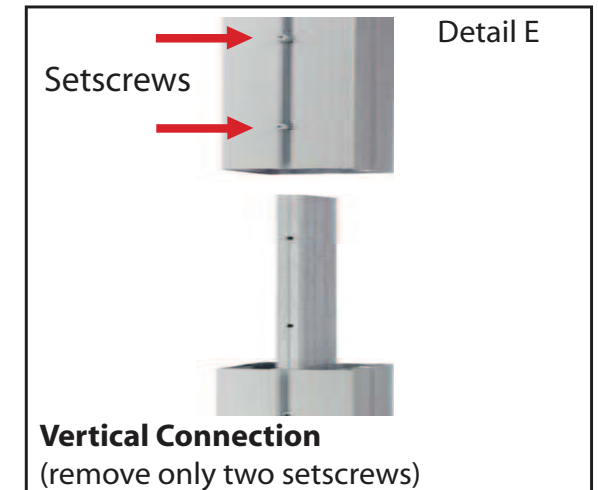

Detail E

Vertical Connection
(remove only two setscrews)

When vertical extrusions are packed in portable cases rather than crates or tubs, they must be broken down into smaller sections which then require assembly.

Remove only (2) setscrews when disassembling. Replace setscrews in extrusion after assembling it. Before packing, replace setscrews in extrusion to avoid losing them.

WHEN DISASSEMBLING ALUMINUM EXTRUSION, TIGHTEN ALL SETSCREWS AND LOCKS TO PREVENT LOSS DURING SHIPPING

866.652.2100

Item	Qty.	Description
1	1	Base Plate
2	1	47.5"h Lower Round Extrusion
3	1	48"h Upper Round Extrusion
4	3	48"h Lower Extrusion
5	2	48"h Upper Extrusion
5a/5b	2/2	25.209"h Vertical Extrusion
6a/6b/6c/6d	1/1/1/1	31.306"w Curved Horizontal Extrusion
6e/6f	2/2	31.306"w Curved Horizontal Extrusion
7	1	31.25"w Curved Horizontal Extrusion
8	2	48"w Horizontal Extrusion
9a/9b	2/2	46.23"h Vertical Extrusion
10	1	10"w Horizontal Extrusion
11	2	8"w Horizontal Extrusion
12a/12b	2/2	31.306"w Curved Horizontal Extrusion
13	1	37.918"h Vertical Extrusion w/ Door Hinges
14	1	37.918"h Vertical Extrusion w/ Door Stop
15	1	37.918"h Vertical Extrusion w/ Door Stop
16	1	37.918"h Vertical Extrusion w/ Door Hinges

Steps:

- 1) Attach vertical extrusion [2] to base plate [1], see detail D on general info. page.
- 2) Attach upper vertical extrusions to lower vertical extrusions [3 to 2 and 5 to 4].
- 3) Attach curved extrusion [7] between vertical assemblies [2/3 and 4/5] with flush to top of verticals
- 4) Attach horizontal extrusions together [6a to 6b, 6c to 6d, 6e to 6f].
- 5) Attach vertical extrusions together [5a to 5b].
- 6) Attach vertical extrusions [5a/5b] between horizontal assemblies as shown, then attach frame assemblies between vertical assemblies [4/5] as shown.
Note: Set extrusion [6e/6f] atop extrusion [6c and 6d].
- 7) Attach vertical extrusions together [9a to 9b].
- 8) Attach vertical assemblies [9a and 9b] between horizontals [8], then attach assembled frame between vertical extrusions [4/5] as shown.
- 9) Assemble shelf support, see shelf support assembly detail.
- 10) Attach curved horizontal extrusions together [12a to 12b], and attach between vertical assemblies [4/5].
- 11) Attach vertical extrusions [13, 14, 15 and 16] to horizontal assembly [12a/12b], leave loose.
- 12) Attach doors between vertical extrusions and place insert as shown, then tighten verticals in place.
- 13) Attach horizontal assembly [12a/12b] between vertical assemblies [4/5] and atop doors and insert, then tightened vertical extrusions to secure.

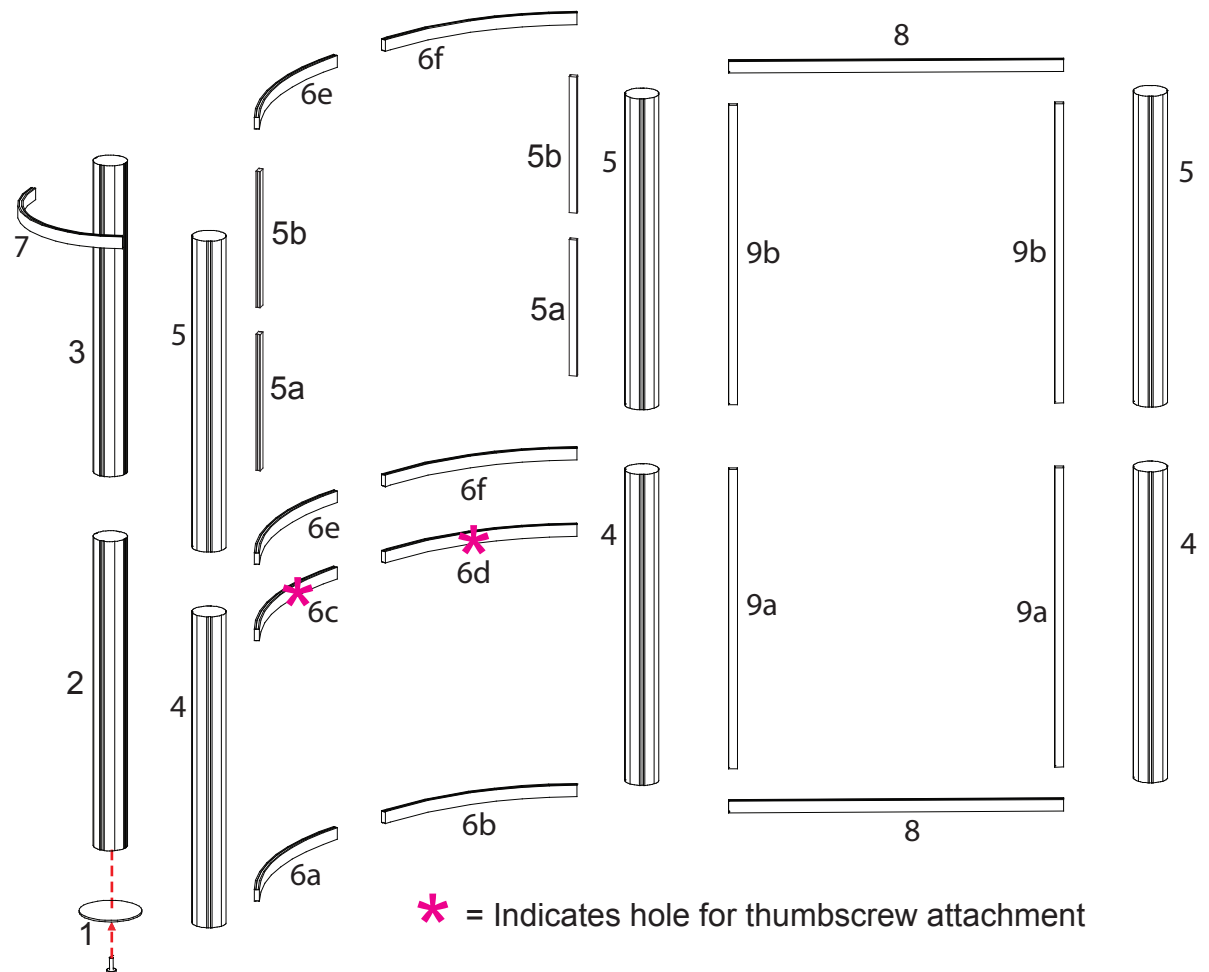
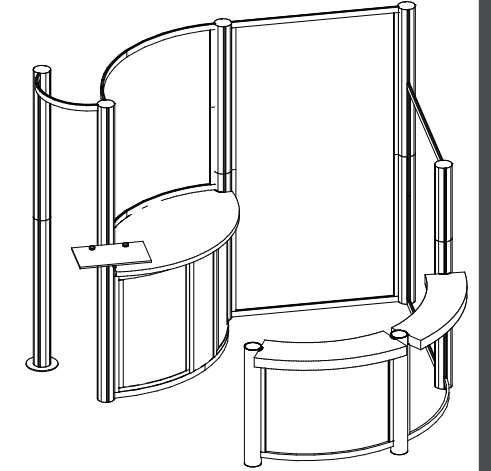

* = Indicates hole for thumbscrew attachment

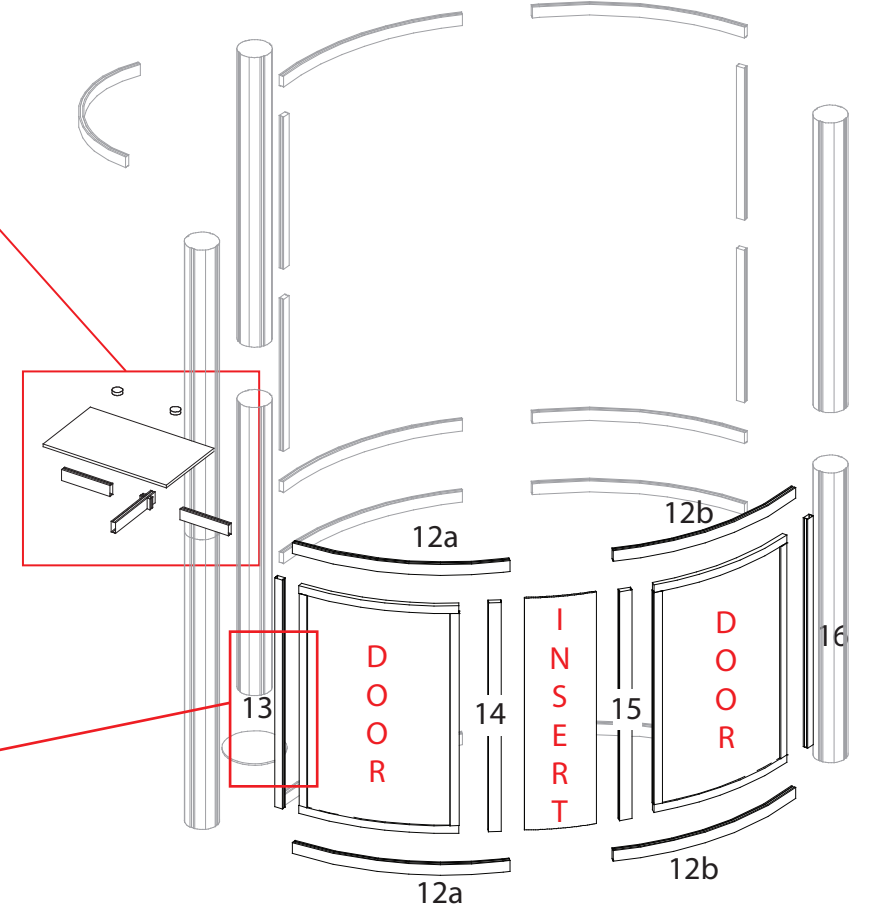
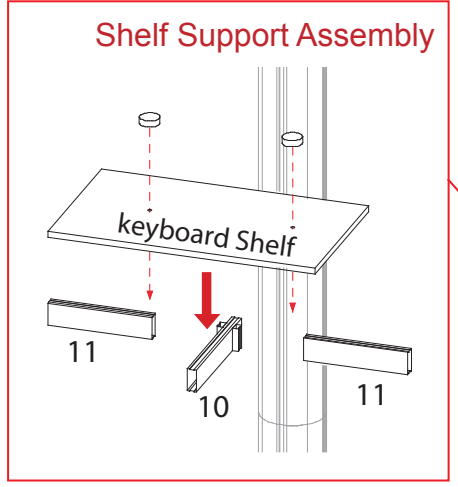

WHEN DISASSEMBLING ALUMINUM EXTRUSION, TIGHTEN ALL SETSCREWS AND LOCKS TO PREVENT LOSS DURING SHIPPING

866.652.2100

Item	Qty.	Description
17	1	48”h Lower Round Extrusion
18	1	24”h Upper Round Extrusion
19	1	38”h Round Extrusion
20	1	38”h Round Extrusion
21	2	48”w Horizontal Extrusion
22a/22b	2/2	34.21”h Vertical Extrusion
23	1	39.6”w Curved Horizontal Extrusion
24	1	39.6”w Curved Horizontal Extrusion
25	2	34.25”h Vertical Extrusion
26	1	39.6”w Curved Horizontal Extrusion
27	1	39.6”w Curved Horizontal Extrusion
28	2	34.25”h Vertical Extrusion
29	4	4”h Horizontal Extrusion
29a	4	4”h Horizontal Extrusion w/ Hole for Thumbscrew Attachment

Steps:

- 1) Attach upper vertical extrusion to lower vertical extrusion [18 to 17].
- 2) Connect vertical extrusions together [22a to 22b].
- 3) Attach vertical assemblies [22a/22b] between horizontal extrusions [17/18 and 4/5] as shown.
- 4) Attach vertical extrusions [25 and 28] between curve horizontal extrusion [23&24 and 26&27].
- 5) Attach assembled frames from previous step between vertical extrusions [17/18, 19 and 20].
- 6) Attach extrusions [29 and 29a] to upper curved horizontal extrusions [24 and 27] to create counter supports.
- 7) Place curve counters atop counter supports and secure with thumbscrews as shown .
- 8) Set alcove counter top on assembled base and secure with thumbscrews to curved horizontal.

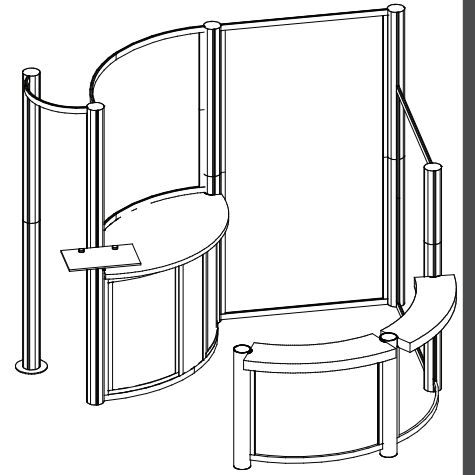

Counter Support Detail

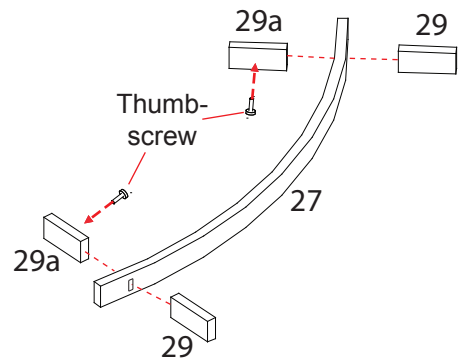

Attach thumbscrews to L-extrusions located at underside of counter tops

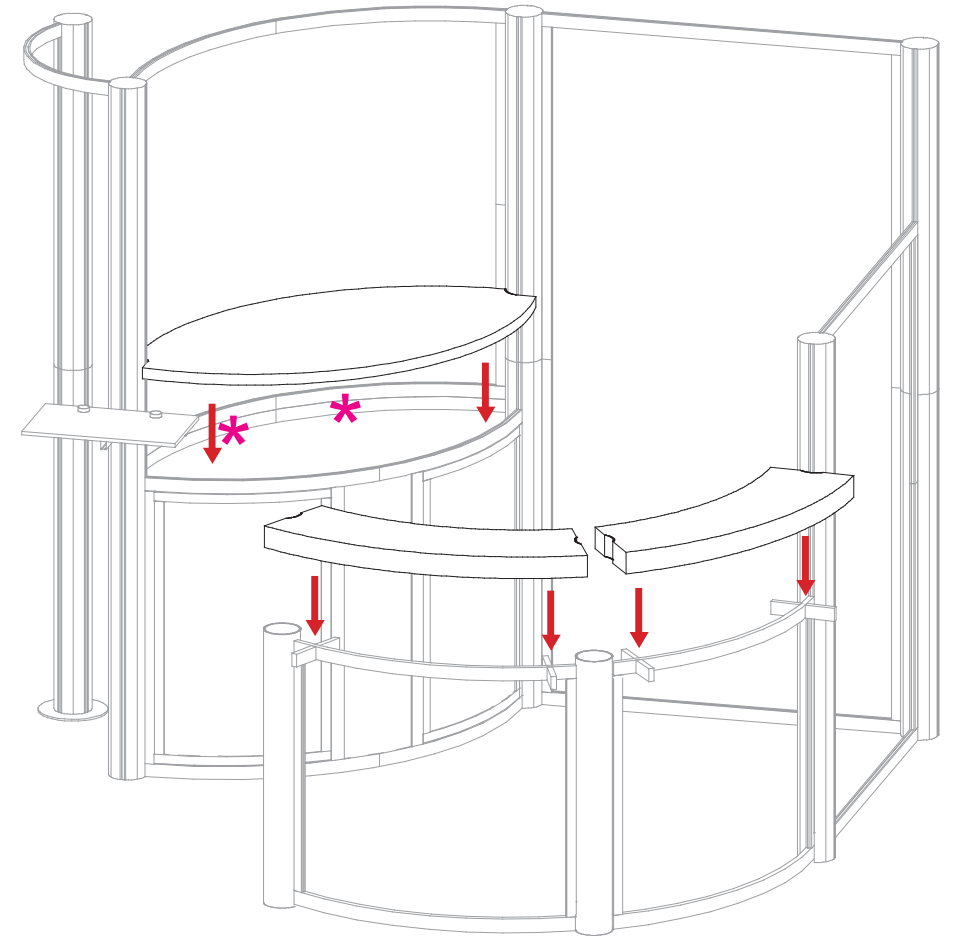
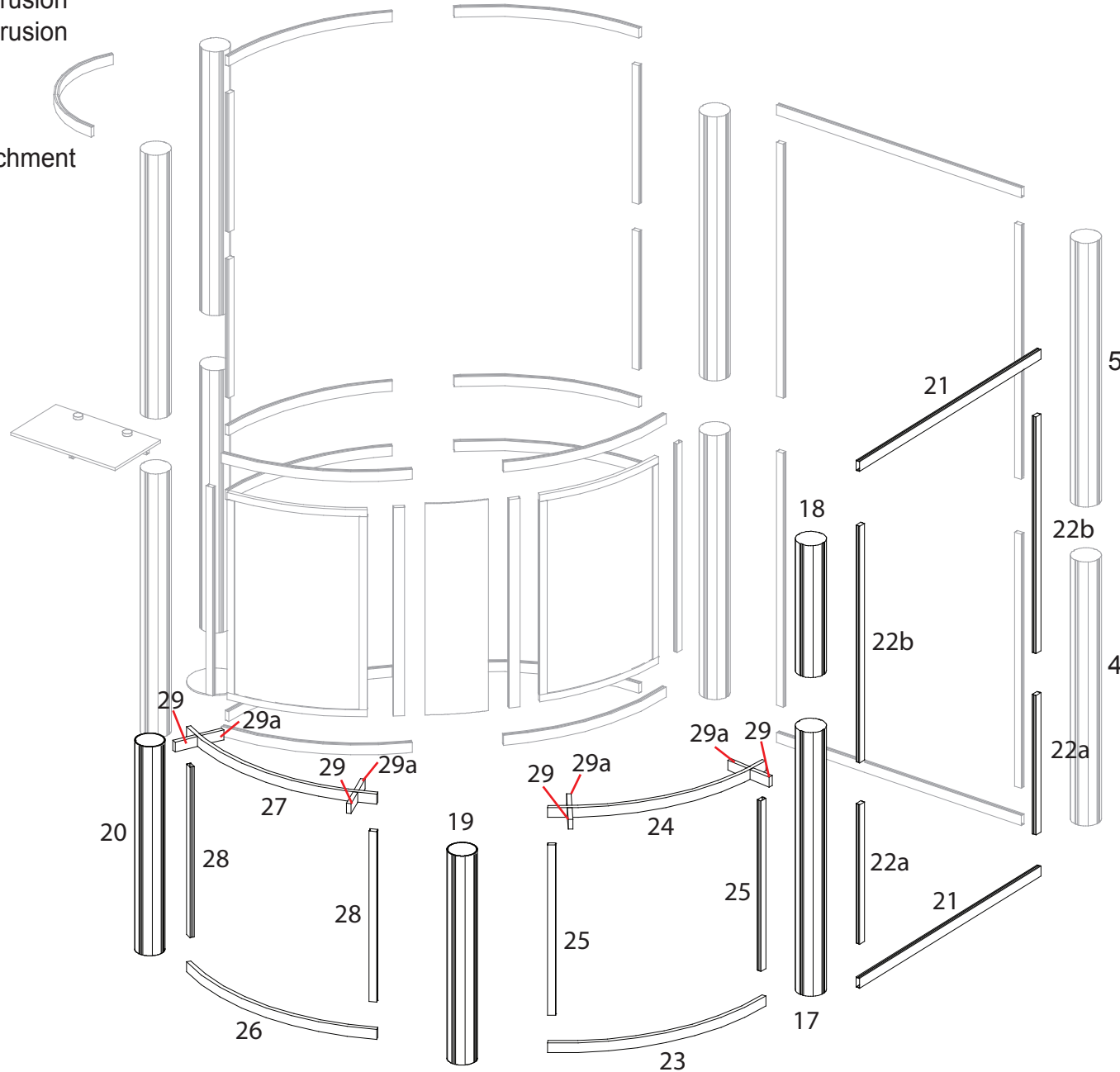

* = Indicates hole for thumbscrew attachment

WHEN DISASSEMBLING ALUMINUM EXTRUSION, TIGHTEN ALL SETSCREWS AND LOCKS TO PREVENT LOSS DURING SHIPPING



8" Extrusion

Qty. : 2
Located in Case : 2

10" Extrusion

Qty. : 1
Located in Case : 2

4" Extrusion

Qty. : 8
Located in Case : 2

31.25" Curved Extrusion

Qty. : 1
Located in Case : 1

31.306" Curved Extrusion

Qty. : 12
Located in Case : 1

48" Extrusion

Qty. : 4
Located in Case : 4

37.918" Extrusion

Qty. : 1
Located in Case : 2

37.918" Extrusion

Qty. : 3
Located in Case : 3

39.6" Curved Extrusion

Qty. : 4
Located in Case : 2

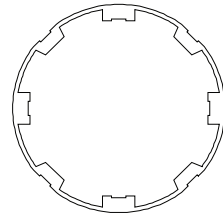

48" Round Extrusion

Qty. : 3
Located in Case : 2

48" Round Extrusion

Qty. : 2
Located in Case : 3

48" Round Extrusion

Qty. : 3
Located in Case : 4

47.75" Round Extrusion

Qty. : 1
Located in Case : 3

38" Round Extrusion

Qty. : 2
Located in Case : 1

24" Round Extrusion

Qty. : 1
Located in Case : 1



34.25" Extrusion

Qty. : 4
Located in Case : 2

34.21" Extrusion

Qty. : 4
Located in Case : 4

25.209" Extrusion

Qty. : 4
Located in Case : 3

46.23" Extrusion

Qty. : 4
Located in Case : 4

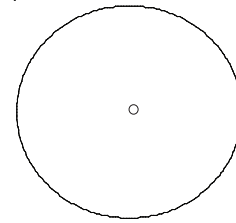

Base Plate

Qty. : 1
Located in Case : 1



Keyboard Shelf

Qty. : 1
Located in Case : 5

Additional Accessories:

Setup Hardware Box

Located in case 1

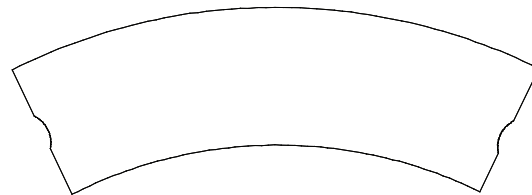

Curve Counter Top

Qty. : 2
Located in Case : 5

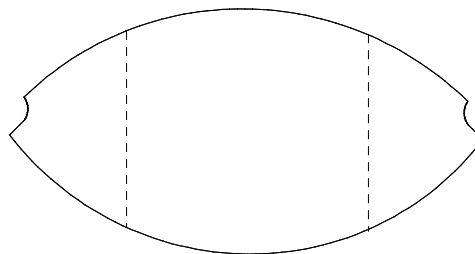

Alcove Counter Top

Qty. : 1
Located in Case : 5

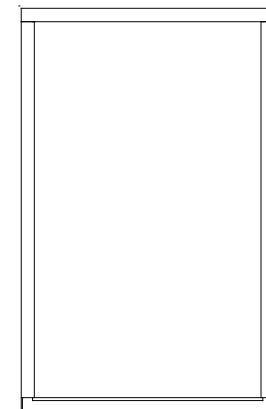

Curved Door

Qty. : 1
Located in Case : 1

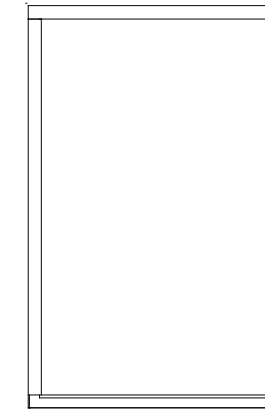

Curved Door

Qty. : 1
Located in Case : 2



Insert

Qty. : 1
Located in Case : 2

WHEN DISASSEMBLING ALUMINUM EXTRUSION, TIGHTEN ALL SETSCREWS AND LOCKS TO PREVENT LOSS DURING SHIPPING



8" Extrusion

Qty. : 2
Located in Case : 2

10" Extrusion

Qty. : 1
Located in Case : 2

4" Extrusion

Qty. : 8
Located in Case : 2

31.25" Curved Extrusion

Qty. : 1
Located in Case : 1

31.306" Curved Extrusion

Qty. : 12
Located in Case : 1

48" Extrusion

Qty. : 4
Located in Case : 4

37.918" Extrusion

Qty. : 1
Located in Case : 2

37.918" Extrusion

Qty. : 3
Located in Case : 3

39.6" Curved Extrusion

Qty. : 4
Located in Case : 2

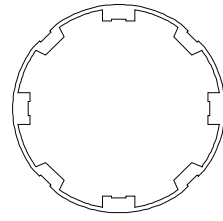

48" Round Extrusion

Qty. : 3
Located in Case : 2

48" Round Extrusion

Qty. : 2
Located in Case : 3

48" Round Extrusion

Qty. : 3
Located in Case : 4

47.75" Round Extrusion

Qty. : 1
Located in Case : 3

38" Round Extrusion

Qty. : 2
Located in Case : 1

24" Round Extrusion

Qty. : 1
Located in Case : 1



34.25" Extrusion

Qty. : 4
Located in Case : 2

34.21" Extrusion

Qty. : 4
Located in Case : 4

25.209" Extrusion

Qty. : 4
Located in Case : 3

46.23" Extrusion

Qty. : 4
Located in Case : 4

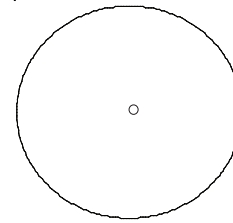

Base Plate

Qty. : 1
Located in Case : 1



Keyboard Shelf

Qty. : 1
Located in Case : 5

Additional Accessories:

Setup Hardware Box

Located in case 1

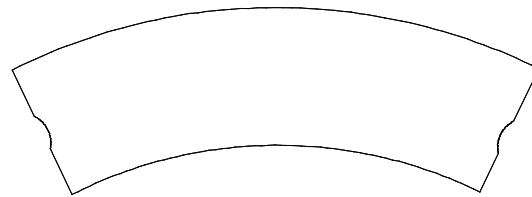

Curve Counter Top

Qty. : 2
Located in Case : 5

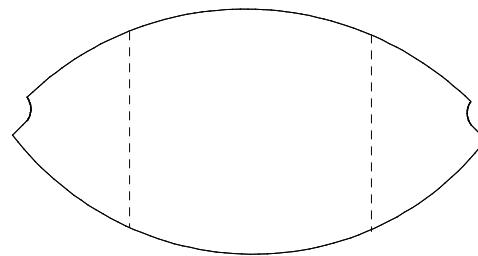

Alcove Counter Top

Qty. : 1
Located in Case : 5

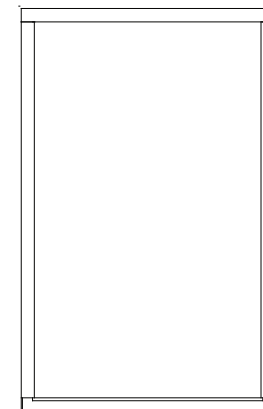

Curved Door

Qty. : 1
Located in Case : 1

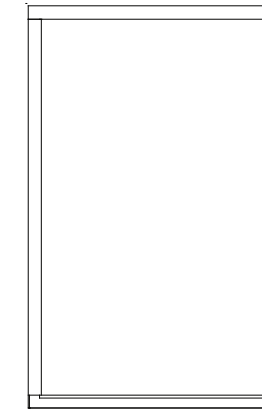

Curved Door

Qty. : 1
Located in Case : 2



Insert

Qty. : 1
Located in Case : 2

WHEN DISASSEMBLING ALUMINUM EXTRUSION, TIGHTEN ALL SETSCREWS AND LOCKS TO PREVENT LOSS DURING SHIPPING



8" Extrusion

Qty. : 2
Located in Case : 2

10" Extrusion

Qty. : 1
Located in Case : 2

4" Extrusion

Qty. : 8
Located in Case : 2

31.25" Curved Extrusion

Qty. : 1
Located in Case : 1

31.306" Curved Extrusion

Qty. : 12
Located in Case : 1

48" Extrusion

Qty. : 4
Located in Case : 4

37.918" Extrusion

Qty. : 1
Located in Case : 2

37.918" Extrusion

Qty. : 3
Located in Case : 3

39.6" Curved Extrusion

Qty. : 4
Located in Case : 2

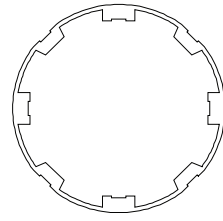

48" Round Extrusion

Qty. : 3
Located in Case : 2

48" Round Extrusion

Qty. : 2
Located in Case : 3

48" Round Extrusion

Qty. : 3
Located in Case : 4

47.75" Round Extrusion

Qty. : 1
Located in Case : 3

38" Round Extrusion

Qty. : 2
Located in Case : 1

24" Round Extrusion

Qty. : 1
Located in Case : 1

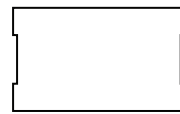

34.25" Extrusion

Qty. : 4
Located in Case : 2

34.21" Extrusion

Qty. : 4
Located in Case : 4

25.209" Extrusion

Qty. : 4
Located in Case : 3

46.23" Extrusion

Qty. : 4
Located in Case : 4

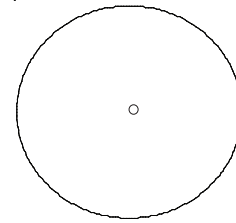

Base Plate

Qty. : 1
Located in Case : 1



Keyboard Shelf

Qty. : 1
Located in Case : 5

Additional Accessories:

Setup Hardware Box

Located in case 1

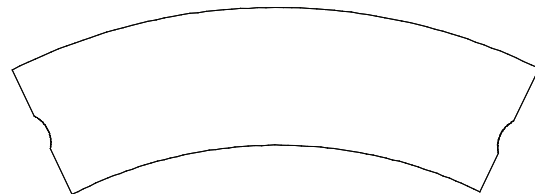

Curve Counter Top

Qty. : 2
Located in Case : 5

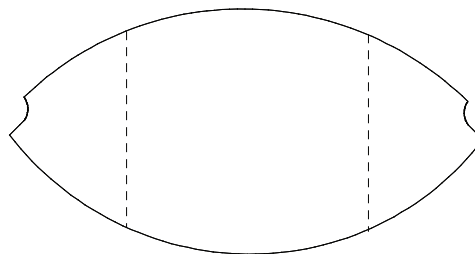

Alcove Counter Top

Qty. : 1
Located in Case : 5

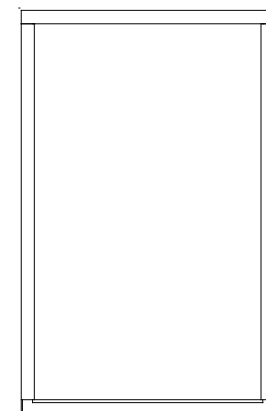

Curved Door

Qty. : 1
Located in Case : 1

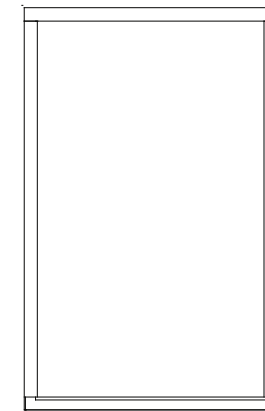

Curved Door

Qty. : 1
Located in Case : 2

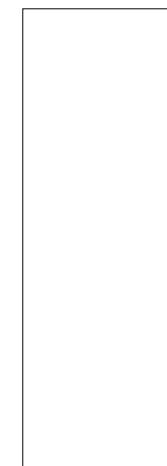

Insert

Qty. : 1
Located in Case : 2

WHEN DISASSEMBLING ALUMINUM EXTRUSION, TIGHTEN ALL SETSCREWS AND LOCKS TO PREVENT LOSS DURING SHIPPING



8" Extrusion

Qty. : 2
Located in Case : 2

10" Extrusion

Qty. : 1
Located in Case : 2

4" Extrusion

Qty. : 8
Located in Case : 2

31.25" Curved Extrusion

Qty. : 1
Located in Case : 1

31.306" Curved Extrusion

Qty. : 12
Located in Case : 1

48" Extrusion

Qty. : 4
Located in Case : 4

37.918" Extrusion

Qty. : 1
Located in Case : 2

37.918" Extrusion

Qty. : 3
Located in Case : 3

39.6" Curved Extrusion

Qty. : 4
Located in Case : 2

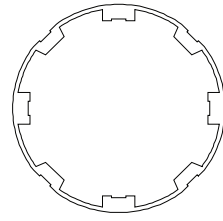

48" Round Extrusion

Qty. : 3
Located in Case : 2

48" Round Extrusion

Qty. : 2
Located in Case : 3

48" Round Extrusion

Qty. : 3
Located in Case : 4

47.75" Round Extrusion

Qty. : 1
Located in Case : 3

38" Round Extrusion

Qty. : 2
Located in Case : 1

24" Round Extrusion

Qty. : 1
Located in Case : 1

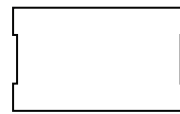

34.25" Extrusion

Qty. : 4
Located in Case : 2

34.21" Extrusion

Qty. : 4
Located in Case : 4

25.209" Extrusion

Qty. : 4
Located in Case : 3

46.23" Extrusion

Qty. : 4
Located in Case : 4

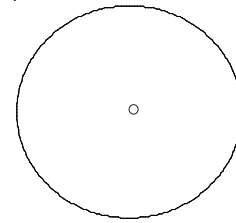

Base Plate

Qty. : 1
Located in Case : 1



Keyboard Shelf

Qty. : 1
Located in Case : 5

Additional Accessories:

Setup Hardware Box

Located in case 1

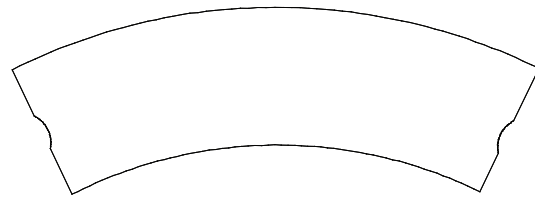

Curve Counter Top

Qty. : 2
Located in Case : 5

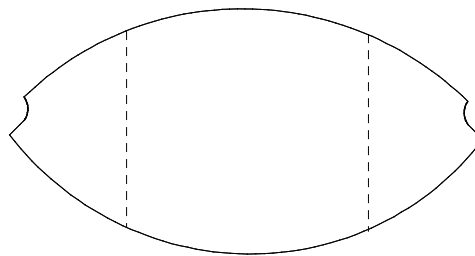

Alcove Counter Top

Qty. : 1
Located in Case : 5

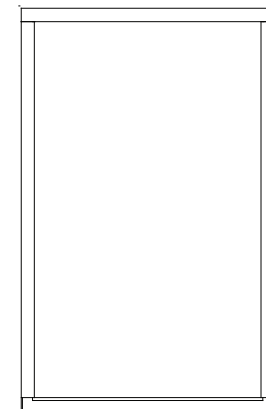

Curved Door

Qty. : 1
Located in Case : 1

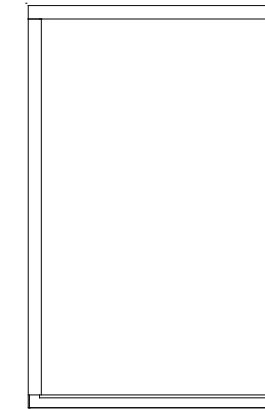

Curved Door

Qty. : 1
Located in Case : 2

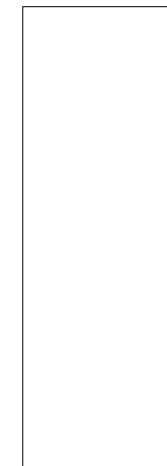

Insert

Qty. : 1
Located in Case : 2

WHEN DISASSEMBLING ALUMINUM EXTRUSION, TIGHTEN ALL SETSCREWS AND LOCKS TO PREVENT LOSS DURING SHIPPING



8" Extrusion

Qty. : 2
Located in Case : 2

10" Extrusion

Qty. : 1
Located in Case : 2

4" Extrusion

Qty. : 8
Located in Case : 2

31.25" Curved Extrusion

Qty. : 1
Located in Case : 1

31.306" Curved Extrusion

Qty. : 12
Located in Case : 1

48" Extrusion

Qty. : 4
Located in Case : 4

37.918" Extrusion

Qty. : 1
Located in Case : 2

37.918" Extrusion

Qty. : 3
Located in Case : 3

39.6" Curved Extrusion

Qty. : 4
Located in Case : 2

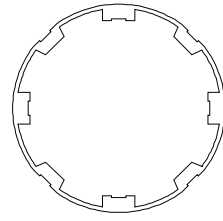

48" Round Extrusion

Qty. : 3
Located in Case : 2

48" Round Extrusion

Qty. : 2
Located in Case : 3

48" Round Extrusion

Qty. : 3
Located in Case : 4

47.75" Round Extrusion

Qty. : 1
Located in Case : 3

38" Round Extrusion

Qty. : 2
Located in Case : 1

24" Round Extrusion

Qty. : 1
Located in Case : 1



34.25" Extrusion

Qty. : 4
Located in Case : 2

34.21" Extrusion

Qty. : 4
Located in Case : 4

25.209" Extrusion

Qty. : 4
Located in Case : 3

46.23" Extrusion

Qty. : 4
Located in Case : 4

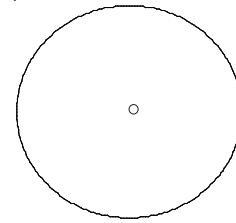

Base Plate

Qty. : 1
Located in Case : 1



Keyboard Shelf

Qty. : 1
Located in Case : 5

Additional Accessories:

Setup Hardware Box

Located in case 1

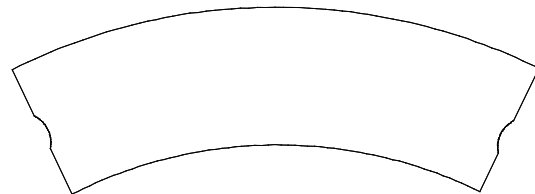

Curve Counter Top

Qty. : 2
Located in Case : 5

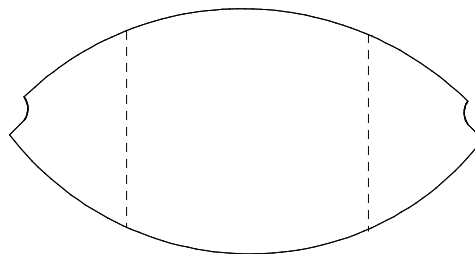

Alcove Counter Top

Qty. : 1
Located in Case : 5

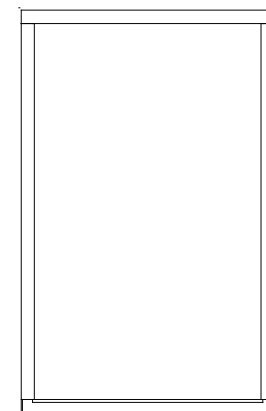

Curved Door

Qty. : 1
Located in Case : 1

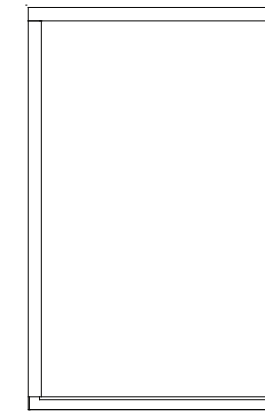

Curved Door

Qty. : 1
Located in Case : 2



Insert

Qty. : 1
Located in Case : 2

WHEN DISASSEMBLING ALUMINUM EXTRUSION, TIGHTEN ALL SETSCREWS AND LOCKS TO PREVENT LOSS DURING SHIPPING