

euro It | HYBRIDS

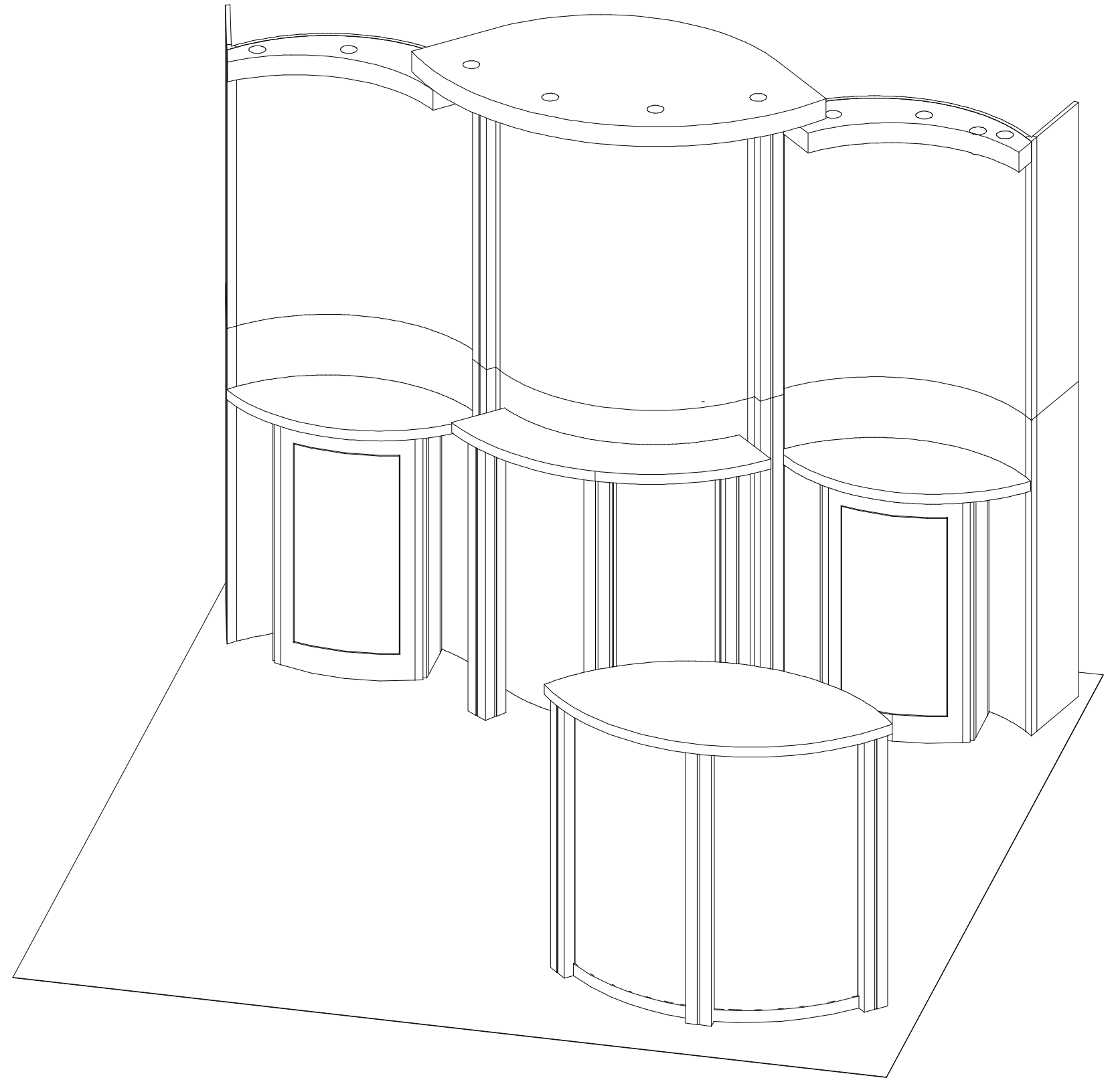
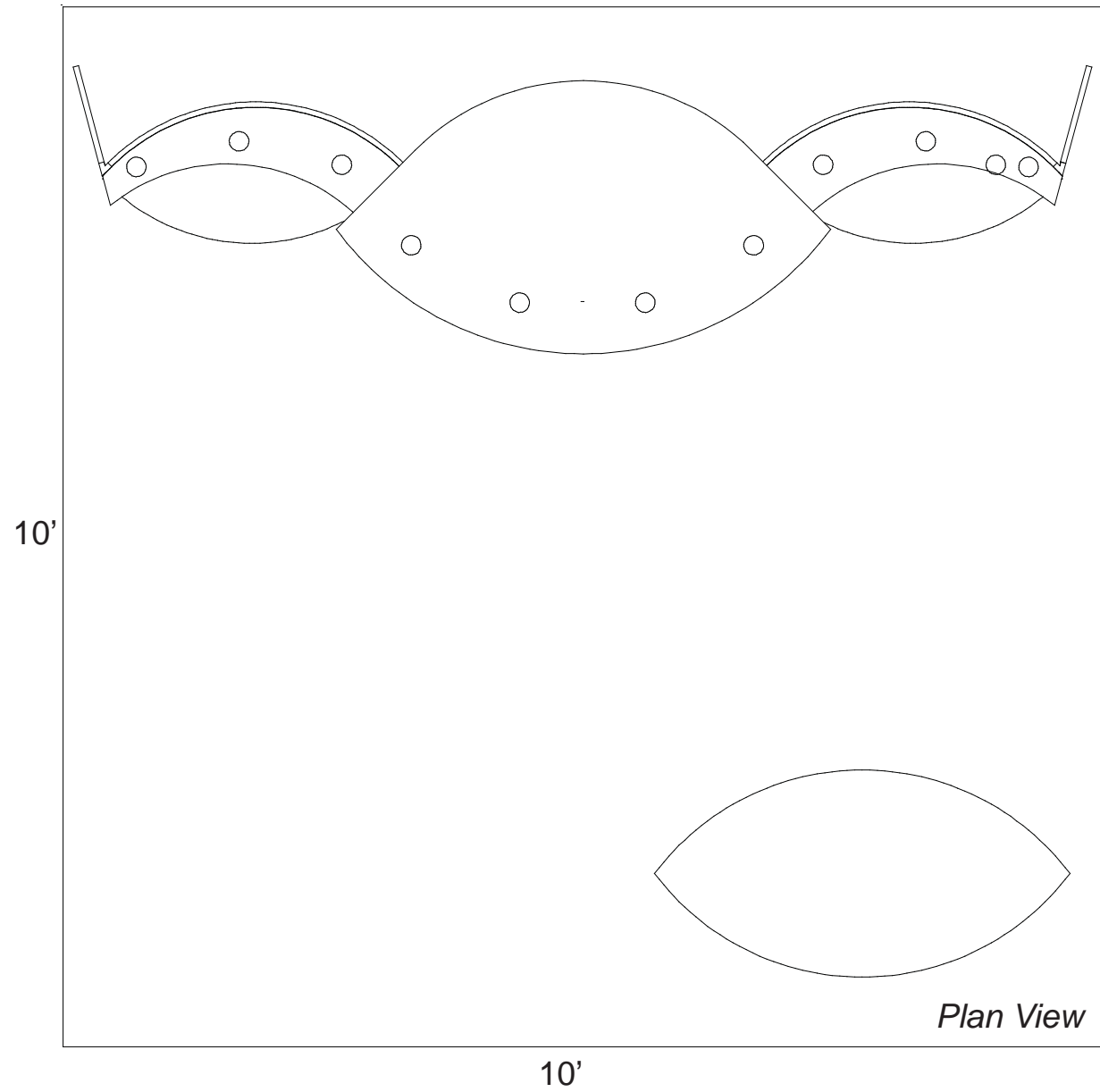

WHEN DISASSEMBLING ALUMINUM EXTRUSION, TIGHTEN ALL SETSCREWS AND LOCKS TO PREVENT LOSS DURING SHIPPING

euro lt | HYBRIDS

Using Your Setup Instructions

The Euro LT Hybrids Setup Instructions are created specifically for your configuration. They are laid out sequentially in levels, including exploded views, and a logical series of detailed steps to assemble the main structure and components. We encourage you to study the instructions **before** attempting to assemble your exhibit.

Each page reminds you to tighten the setscrews after disassembling your exhibit to prevent loss of the locks and setscrews (see below in RED). This is VERY IMPORTANT.

Cleaning and Packing Your Display

- 1) Use care when cleaning aluminum extrusion or acrylic inserts. Use only non-abrasive cleaners.
- 2) When cleaning laminate inserts, countertops, or panels use mild cleansers and a soft material such as cotton.
- 3) Keep all display components away from extreme heat and long exposure to sunlight to avoid warping and fading.
- 4) Retain all packing material. It will make re-packing much easier and will reduce the likelihood of shipping damage.

General Setup Instructions for Extrusion System



The Tool

Most exhibits can be assembled with the supplied Hex Key Tool. Occasionally, a flat head screwdriver may be required.



Typical Connection

Most horizontal extrusion connections have a patented expandable lock. This lock inserts into the groove of an opposing extrusion. Tightening the lock with the Hex Key Tool expands the lock and creates a strong positive connection.



Typical Connection (cont'd)

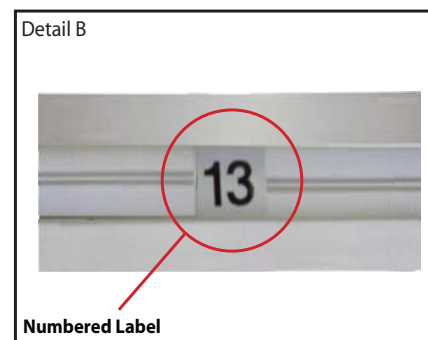

Numbered Label

Each extrusion contains a numbered label which corresponds with setup instructions. The label is located within a groove of the extrusion (when possible). With extrusion components the labels contain Black numbers unless otherwise specified.



Horizontal Inline Connection (remove only one setscrew)

Remove only (1) setscrew when disassembling. Replace setscrew in extrusion after assembling it. Before packing, replace setscrew in extrusion to avoid losing it.

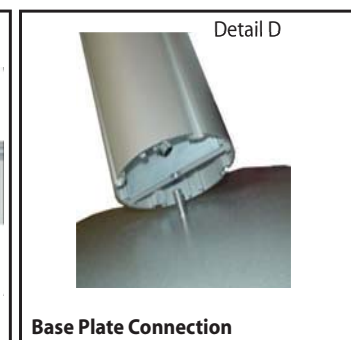

Base Plate Connection

Attach base plate to round or square vertical extrusion using the bolt provided. Be careful not to strip the threads.

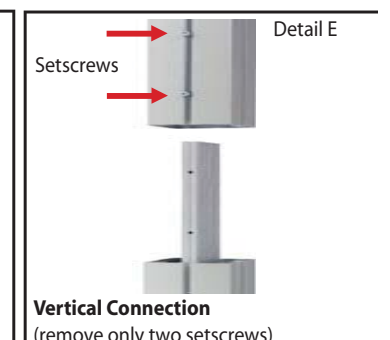

Vertical Connection (remove only two setscrews)

When vertical extrusions are packed in portable cases rather than crates or tubs, they must be broken down into smaller section which then require assembly.

Remove only (2) setscrews when disassembling. Replace setscrews in extrusion after assembling it. Before packing, replace setscrews in extrusion to avoid losing them.

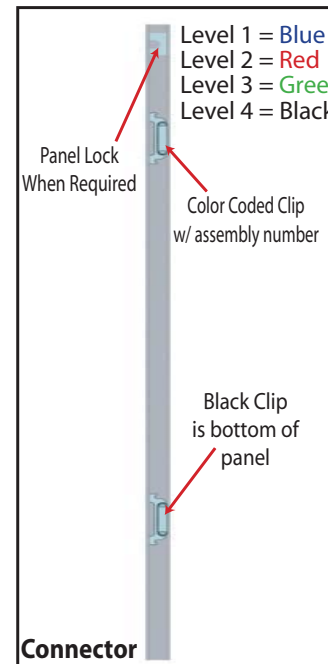

Connector

Each component has 2 clips, the lower clip is ALWAYS black. The top clip is color coded to distinguish which level. The color coded clip also contains the numbered label.

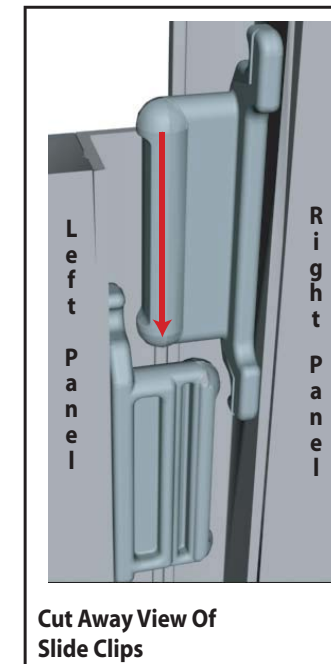

Cut Away View Of Slide Clips

Components connect together by aligning them and sliding downward connecting clips together.

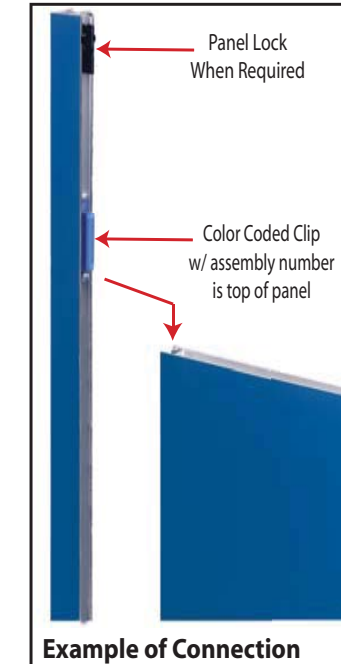

Example of Connection

Configurations are assembled from left to right, usually starting with #1 and following the numbered sequence.

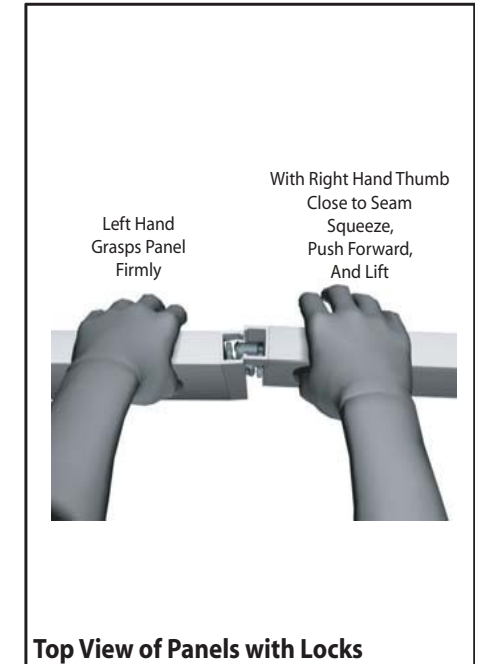

Top View of Panels with Locks

The first level of components contain panel locks that are located at the top of the panel for extra stability and seamless connection. When disassembling panels twist top connection slightly and lift right panel upward.

WHEN DISASSEMBLING ALUMINUM EXTRUSION, TIGHTEN ALL SETSCREWS AND LOCKS TO PREVENT LOSS DURING SHIPPING

866.652.2100

EURO LT Panel System: Part List

Item Number	Description
1	11.5"w x 47.5"h Flat Panel
2	47.5"h 60° Connector
3	23"r x 47.5"h Curved Panel
6	23"r x 47.5"h Curved Panel
7	23"r x 47.5"h Curved Panel
10	23"r x 47.5"h Curved Panel
11	47.5"h 60° Connector
12	11.5"w x 47.5"h Flat Panel

Modul Extrusion System: Part List

Item Number	QTY.	Description
4	1	47.5"h Vertical Extrusion w/ Connector Attached
5	1	47.5"h Vertical Extrusion w/ Connector Attached
8	1	47.5"h Vertical Extrusion w/ Connector Attached
9	1	47.5"h Vertical Extrusion w/ Connector Attached

Steps:

- 1) Connect Vertical Extrusions 5 to 4 and 9 to 8.
- 2) Connect panels together in numerical order, attaching to vertical extrusions as shown in illustrations.

Top View of Vertical Extrusion w/ Connectors Attached

Top View of Vertical Extrusion w/ Connectors Attached

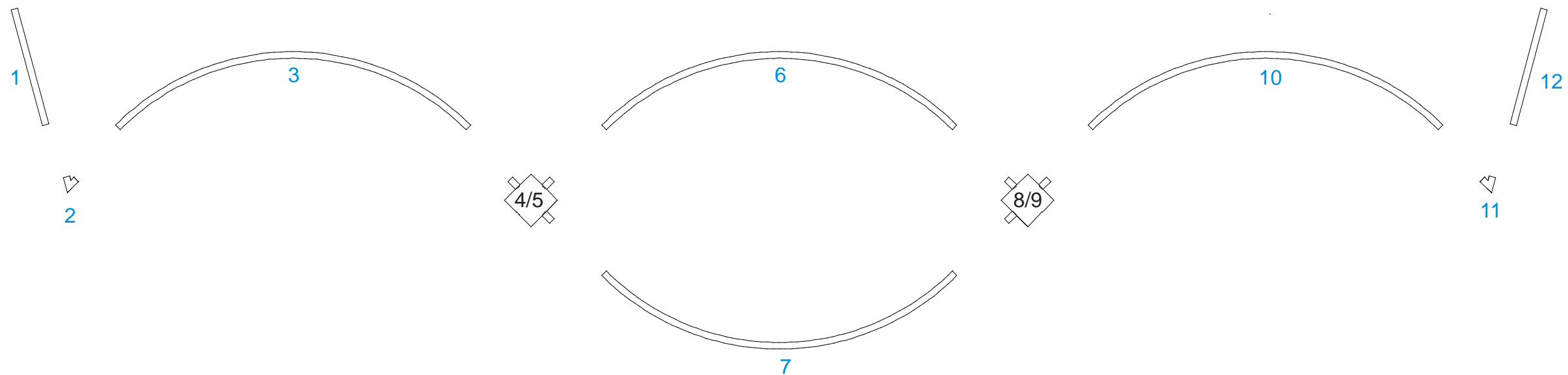
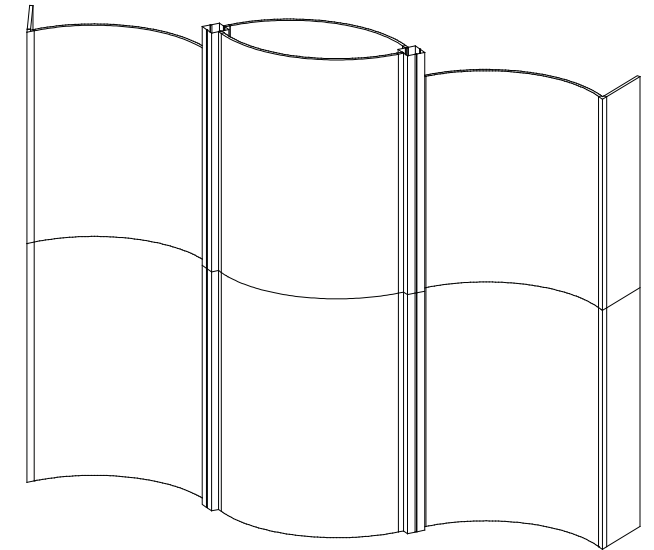
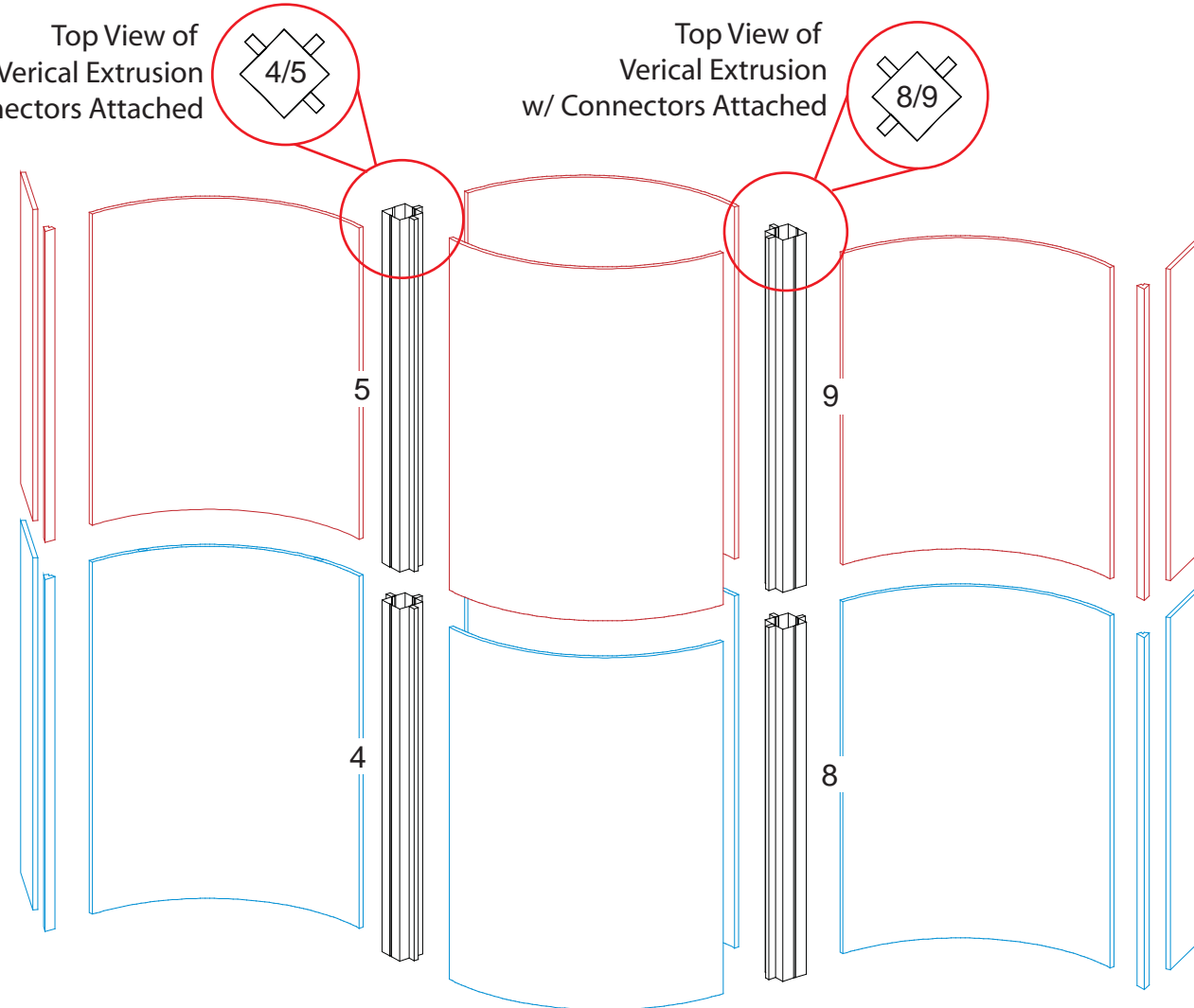

WHEN DISASSEMBLING ALUMINUM EXTRUSION, TIGHTEN ALL SETSCREWS AND LOCKS TO PREVENT LOSS DURING SHIPPING

EURO LT Panel System: Part List

Item Number	Description
1	11.5"w x 42"h Flat Panel
2	42"h 60° Connector
3	23"r x 42"h Curved Panel
6	23"r x 47.5"h Curved Panel
7	23"r x 47.5"h Curved Panel
10	23"r x 42"h Curved Panel
11	42"h 60° Connector
12	11.5"w x 42"h Flat Panel

Modul Extrusion System: Part List

Item Number	QTY.	Description
4	1	47.5"h Vertical Extrusion w/ Connector Attached
5	1	47.5"h Vertical Extrusion w/ Connector Attached
8	1	47.5"h Vertical Extrusion w/ Connector Attached
9	1	47.5"h Vertical Extrusion w/ Connector Attached

Steps:

- 1) Connect panels together in numerical order, attaching to vertical extrusions as shown in illustrations.

Top View of Vertical Extrusion w/ Connectors Attached

Top View of Vertical Extrusion w/ Connectors Attached

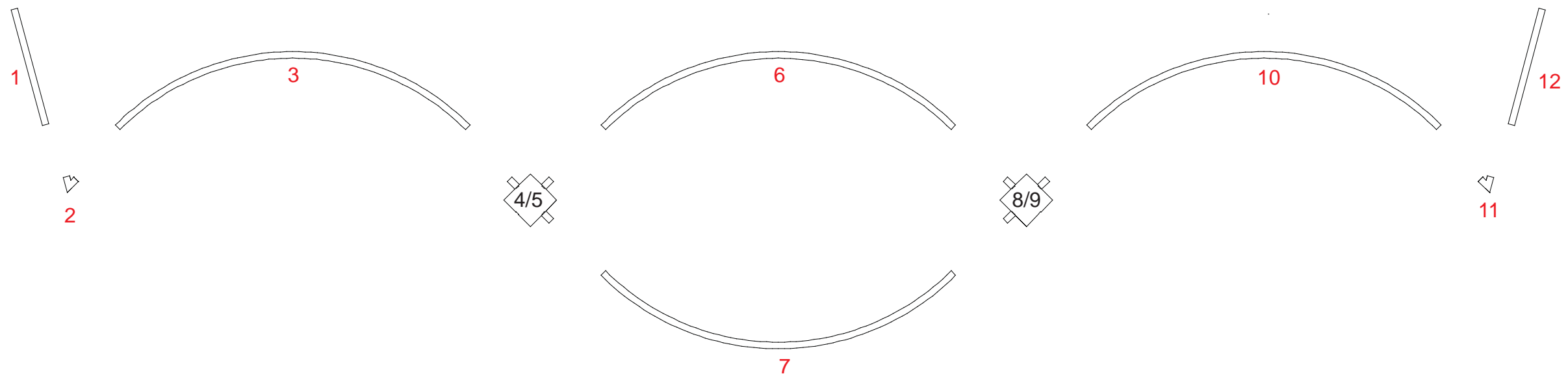
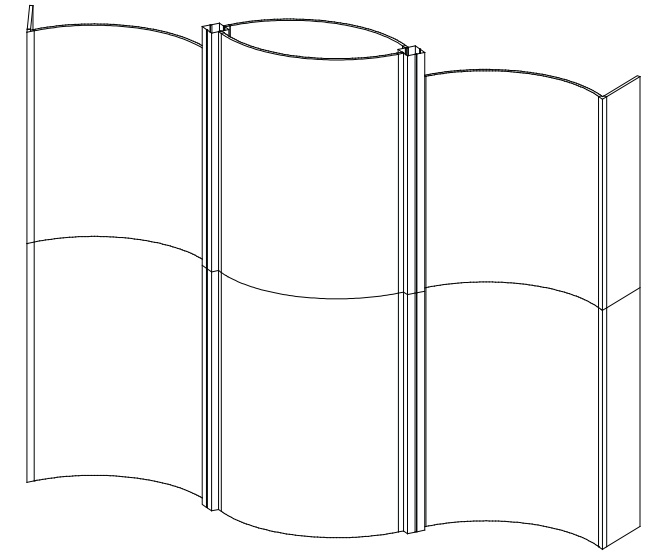
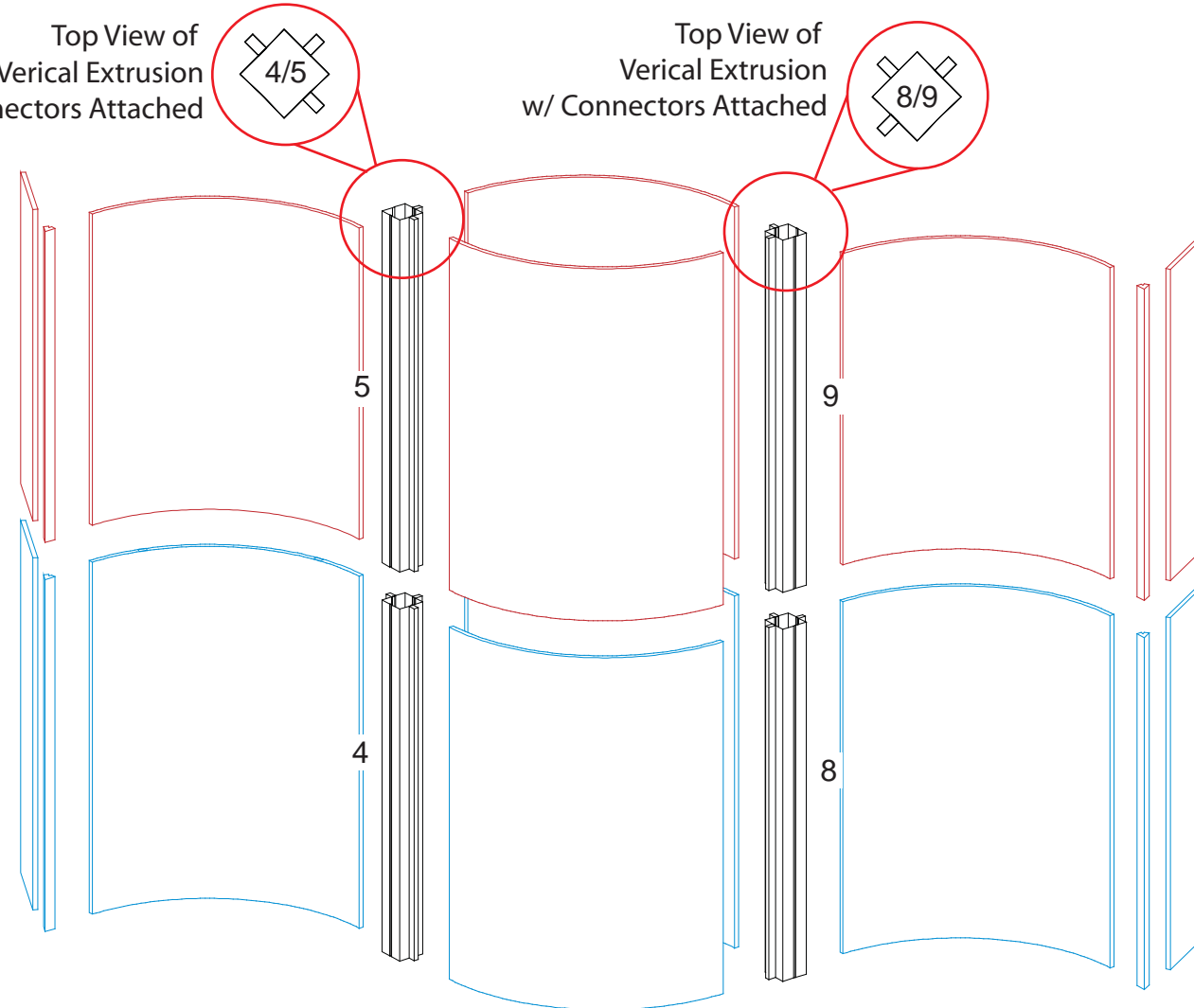

WHEN DISASSEMBLING ALUMINUM EXTRUSION, TIGHTEN ALL SETSCREWS AND LOCKS TO PREVENT LOSS DURING SHIPPING

866.652.2100

EURO LT Panel System: Part List

Item Number	Description	Item Number	Description
13	18.981w x 38" h Flat Panel	21	18.981w x 38" h Flat Panel
14	38" h 90° Connector	22	38" h 90° Connector
15	6.25" w x 38" h Flat Panel	23	6.25" w x 38" h Flat Panel
16	38" h Flex Connector	24	38" h Flex Connector
17	23" r x 38" h Curve Panel	25	23" r x 38" h Curve Panel
18	38" h Flex Connector	26	38" h Flex Connector
19	6.25" w x 38" h Flat Panel	27	6.25" w x 38" h Flat Panel
20	38" h 90° Connector	28	38" h 90° Connector

Modul Extrusion System: Part List

Item Number	QTY.	Description
29	3	42" h Counter Support Leg
30	1	14.75" w Counter Support Extrusion
31	1	14.75" w Counter Support Extrusion

Steps:

- 1) Assemble counters by starting at panel #13 and continue in numerical order.
- 2) Place counter bases against backwall as indicated.
- 3) Attach counter supports [30 and 31] between counter support legs [29], then place counter support assembly in front of assembled backwall as indicated.
- 4) Set counters atop bases and support legs as shown, and secure with thumbscrews.
- 5) Hook ceiling top top of assembled backwall as shown.

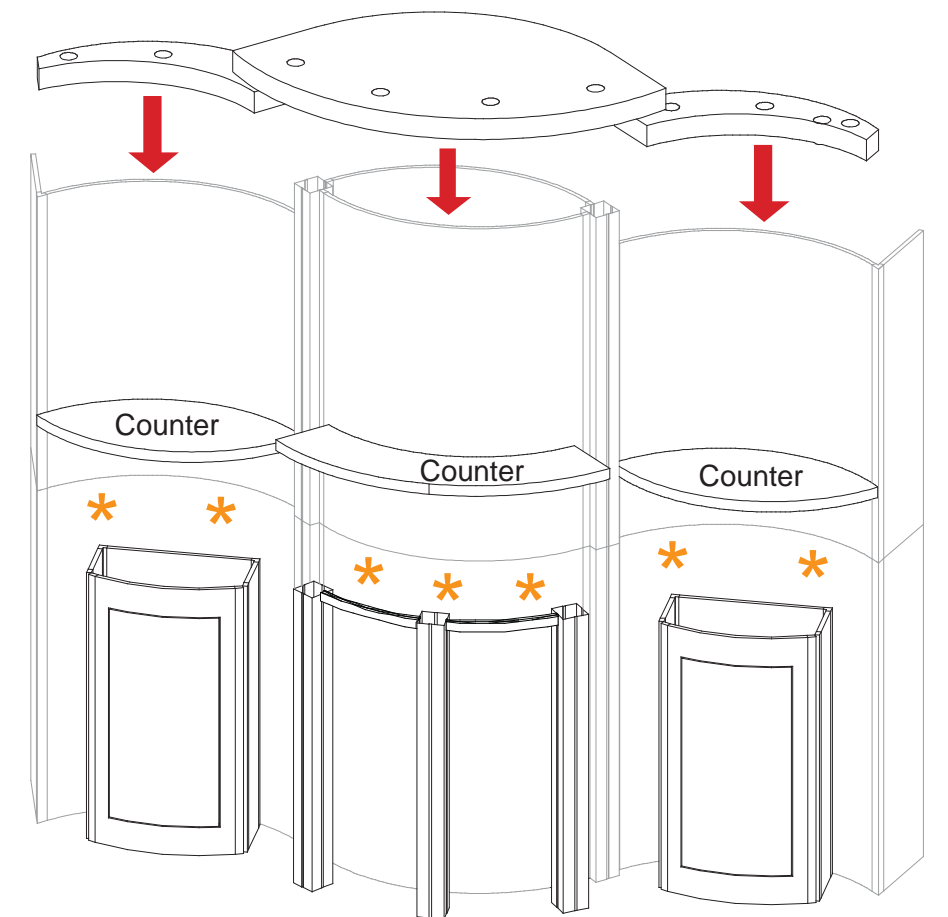
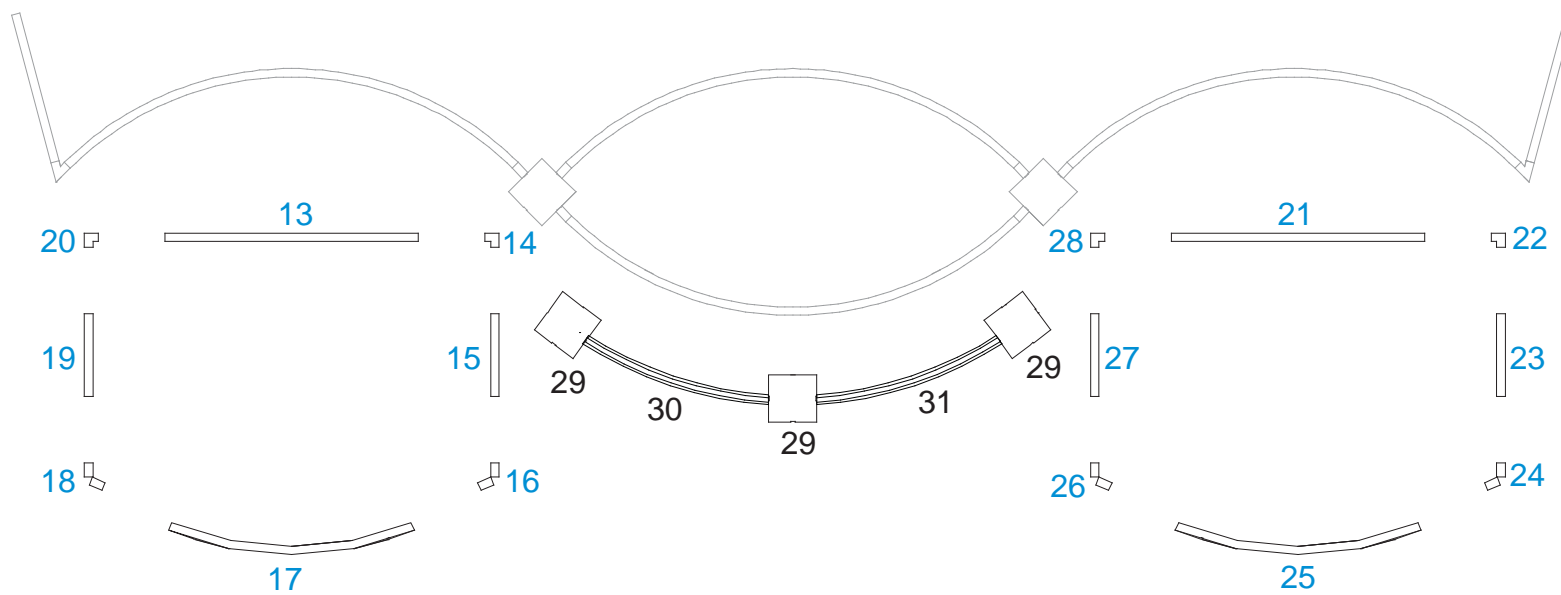
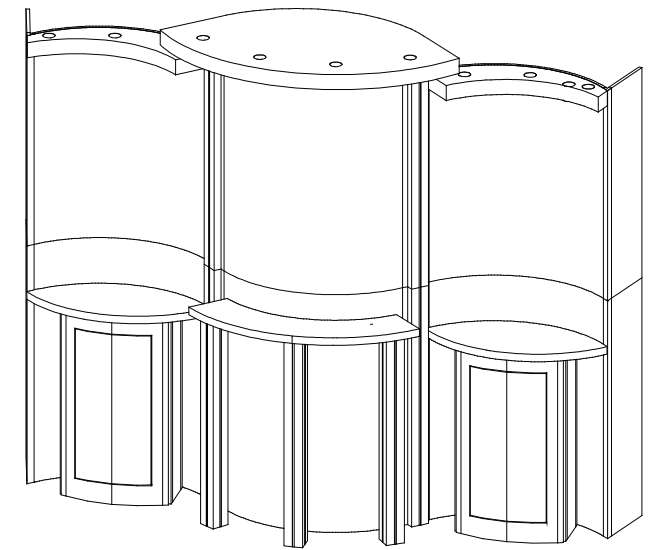

* = Thumbscrew Location

WHEN DISASSEMBLING ALUMINUM EXTRUSION, TIGHTEN ALL SETSCREWS AND LOCKS TO PREVENT LOSS DURING SHIPPING

866.652.2100

Item Number	QTY.	Description
32	1	42" h Vertical Extrusion
33	1	42" h Vertical Extrusion
34	1	42" h Vertical Extrusion
35	1	42" h Vertical Extrusion
36	4	20.09" w Curved Horizontal Extrusion w/ Angle Cut on One Side of Extrusion
37	4	20.09" w Curved Horizontal Extrusion w/ Angle Cut on One Side of Extrusion

Steps:

- 1) Attach curved horizontal extrusions [36] between vertical extrusions [32, 33, 34 and 35], see extrusion attachment detail.
- 2) Place inserts and door in place.
- 3) Attach upper curved horizontal extrusions [37] between [32, 33, 34 and 35] and atop inserts and door, see extrusion attachment detail.
- 4) Velcro shelf supports to inside of assembled base, then set internal shelf atop supports.
- 5) Set counter top on assembled base.

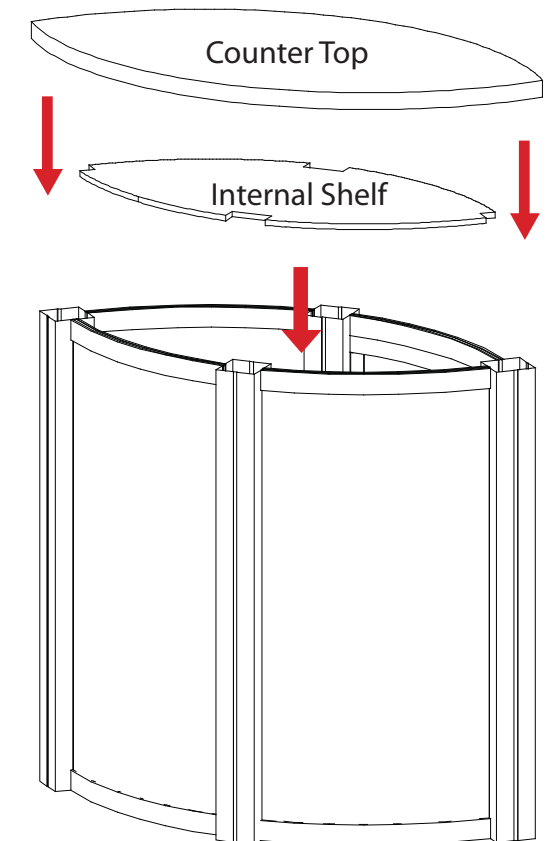
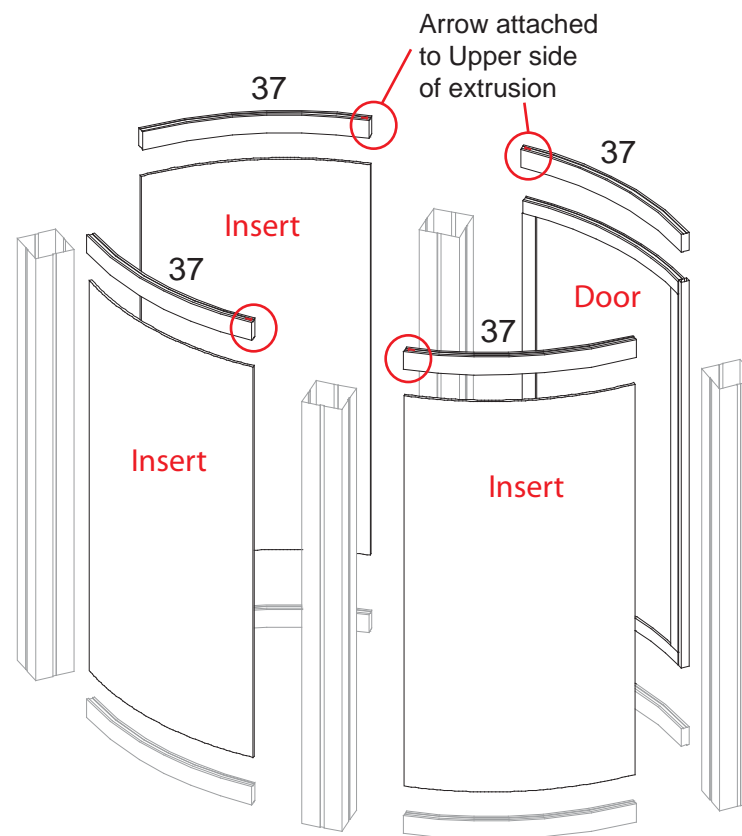
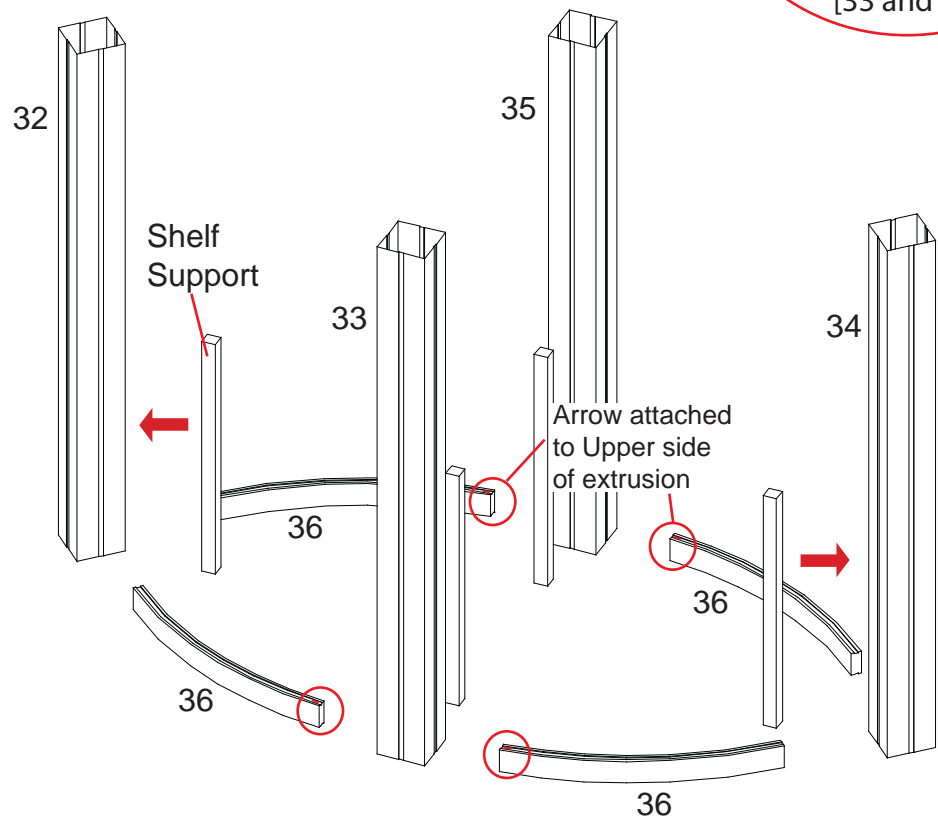
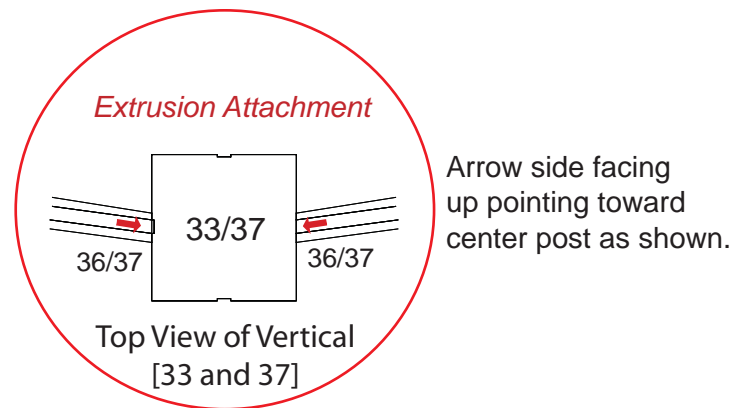
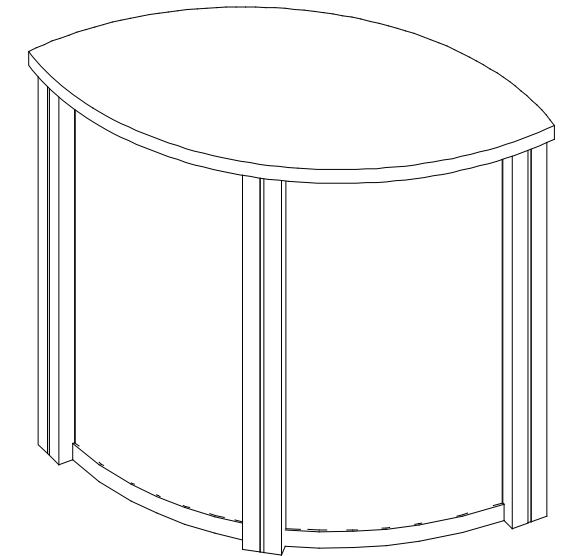

WHEN DISASSEMBLING ALUMINUM EXTRUSION, TIGHTEN ALL SETSCREWS AND LOCKS TO PREVENT LOSS DURING SHIPPING

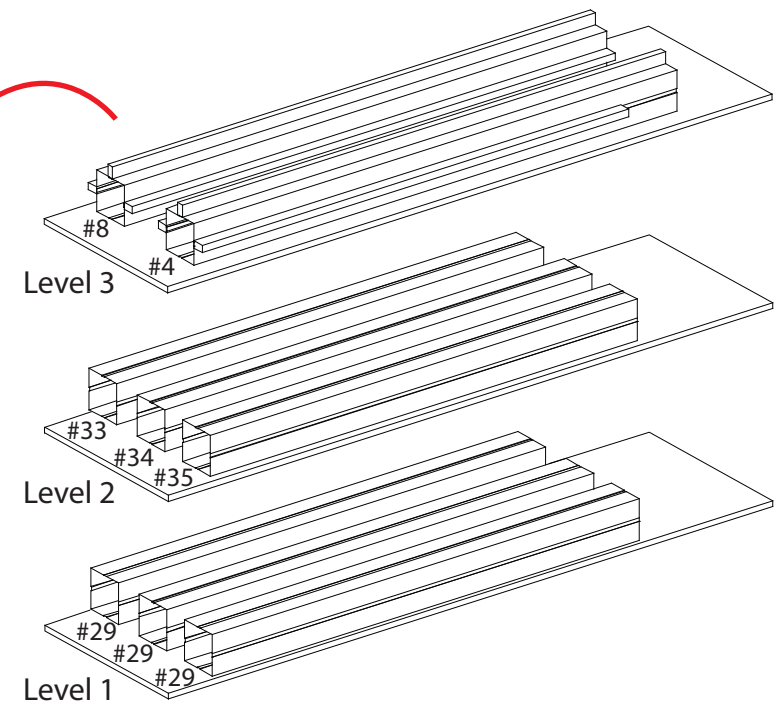
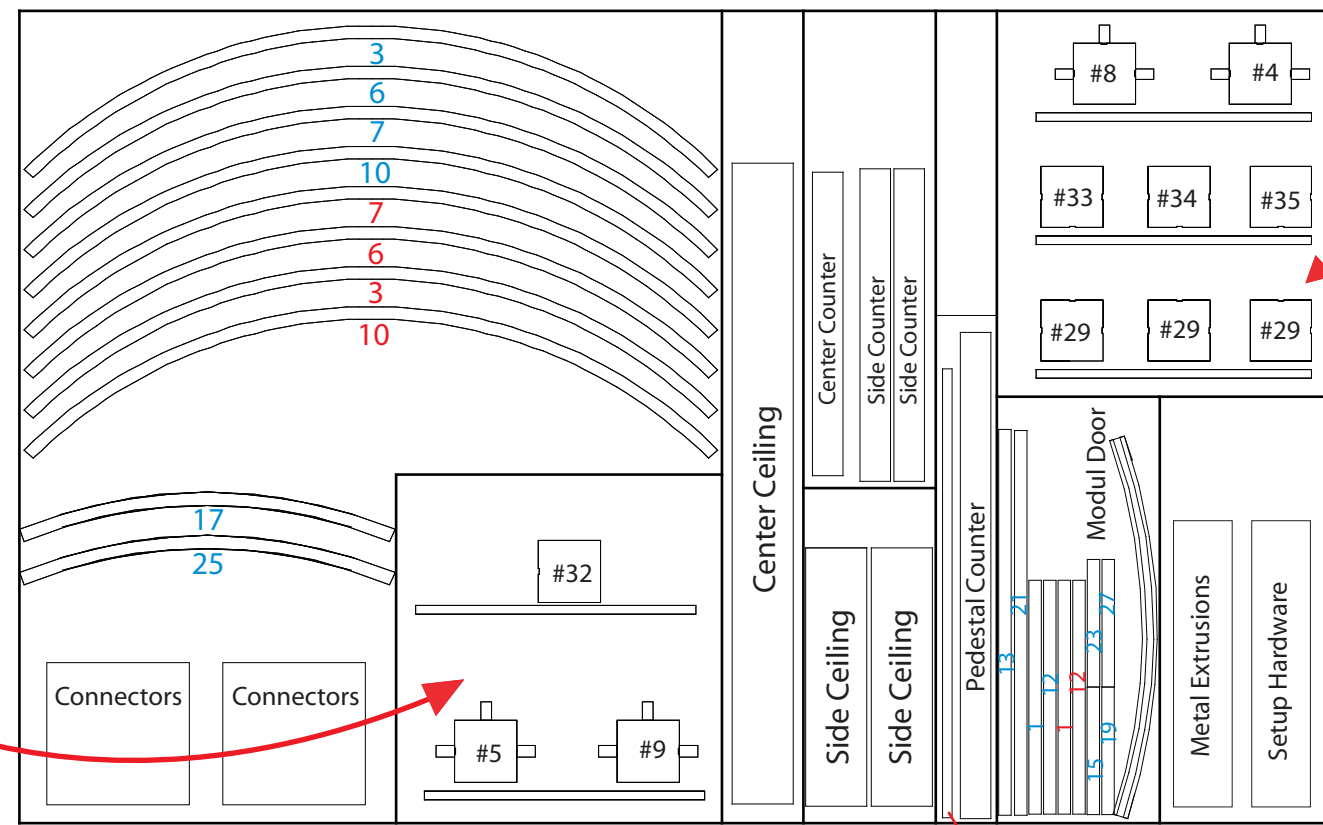
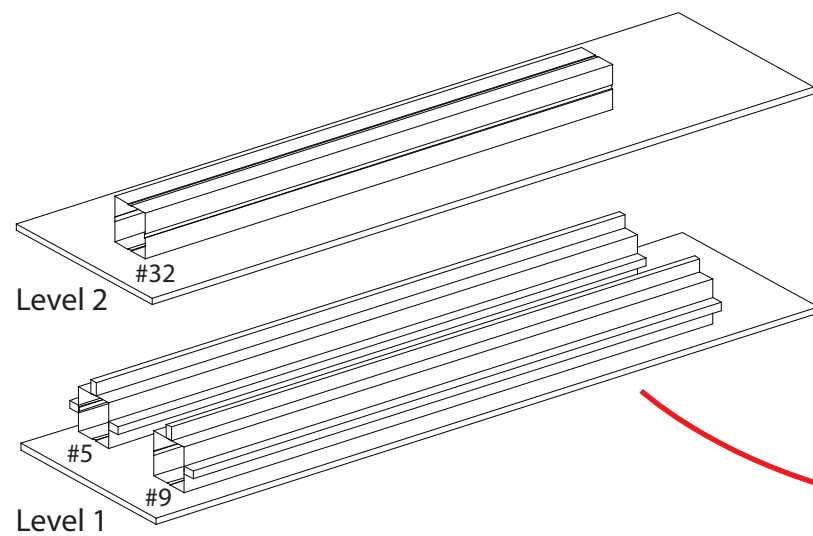
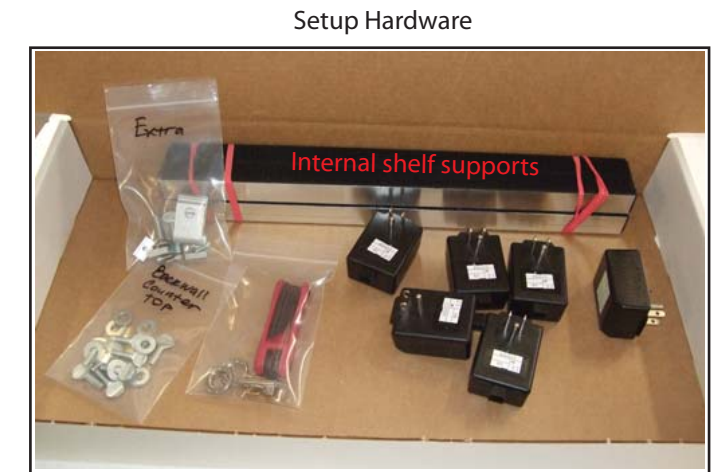
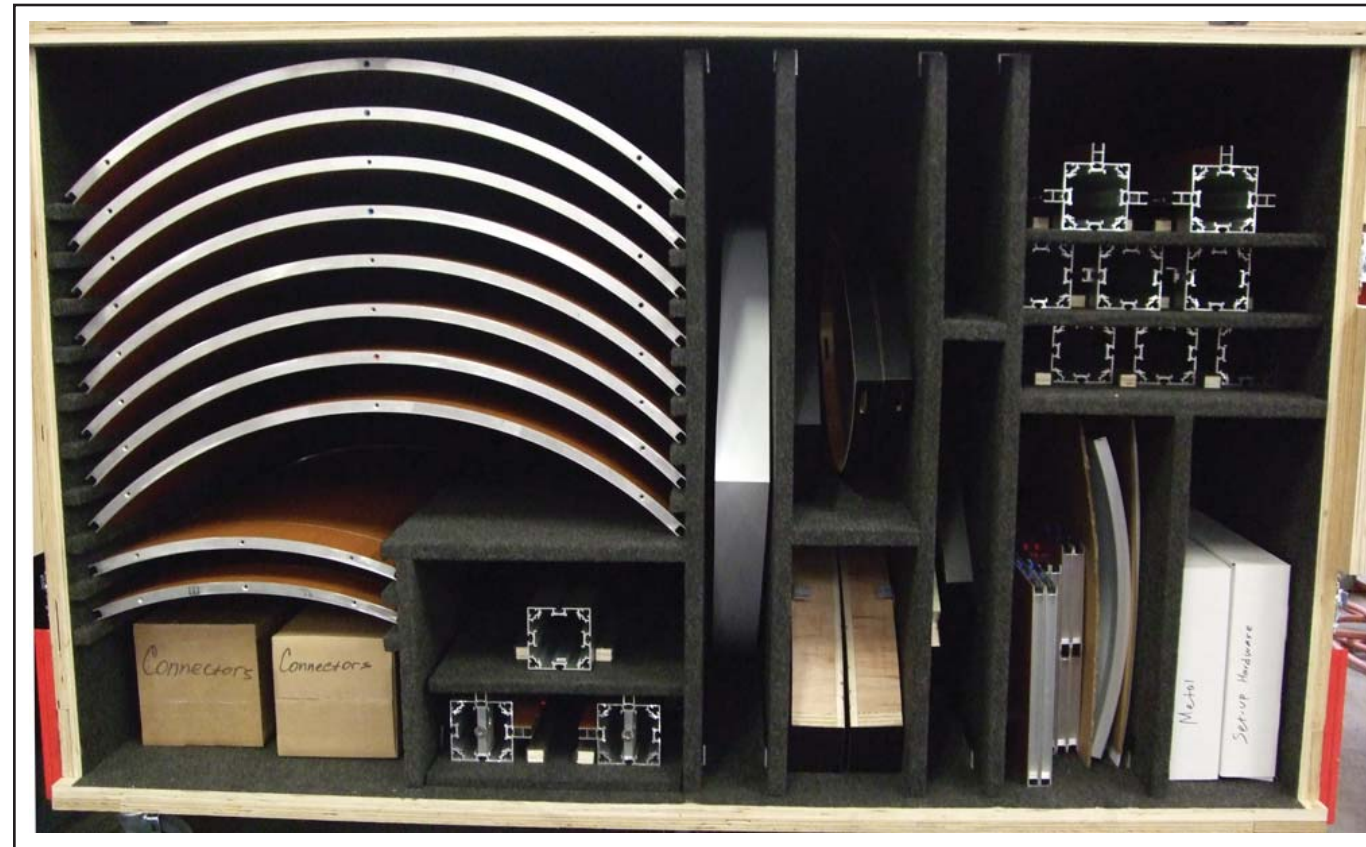

WHEN DISASSEMBLING ALUMINUM EXTRUSION, TIGHTEN ALL SETSCREWS AND LOCKS TO PREVENT LOSS DURING SHIPPING