

WHEN DISASSEMBLING ALUMINUM EXTRUSION, TIGHTEN ALL SETSCREWS AND LOCKS TO PREVENT LOSS DURING SHIPPING

visionary™ DESIGNS

Using Your Setup Instructions

The Visionary Designs Setup Instructions are created specifically for your configuration. They are laid out sequentially, including an exploded view of the entire display, and then a logical series of detailed steps to assemble the main structure and components. We encourage you to study the instructions **before** attempting to assemble your exhibit.

Each page reminds you to tighten the setscrews after disassembling your exhibit to prevent loss of the locks and setscrews (see below in RED). This is **VERY IMPORTANT**.

Cleaning and Packing Your Display

- 1) Use care when cleaning aluminum extrusion or acrylic inserts. Use only non-abrasive cleaners.
- 2) When cleaning laminate inserts or countertops, use mild cleansers and a soft material such as cotton.
- 3) Keep all display components away from extreme heat and long exposure to sunlight to avoid warping and fading.
- 4) Retain all packing material. It will make re-packing much easier and will reduce the likelihood of shipping damage.



The Tool

Most Visionary Designs exhibits can be assembled with the supplied Hex Key Tool. Occasionally, a flat head screwdriver may be required.



Typical Connection

Most horizontal extrusion connections have a patented expandable lock. This lock inserts into the groove of an opposing extrusion. Tightening the lock with the Hex Key Tool expands the lock and creates a strong positive connection.



Typical Connection (cont'd)

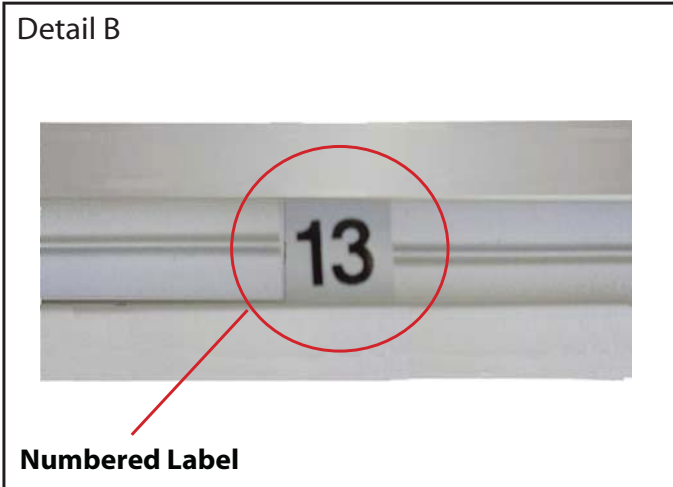

Detail B

Numbered Label

Each extrusion contains a numbered label which corresponds with setup instructions. The label is located within a groove of the extrusion (when possible). With Visionary Designs the labels contain Black numbers unless otherwise specified.



Detail C

Horizontal Inline Connection (remove only one setscrew)

Remove only (1) setscrew when disassembling. Replace setscrew in extrusion after assembling it. Before packing, replace setscrew in extrusion to avoid losing it.

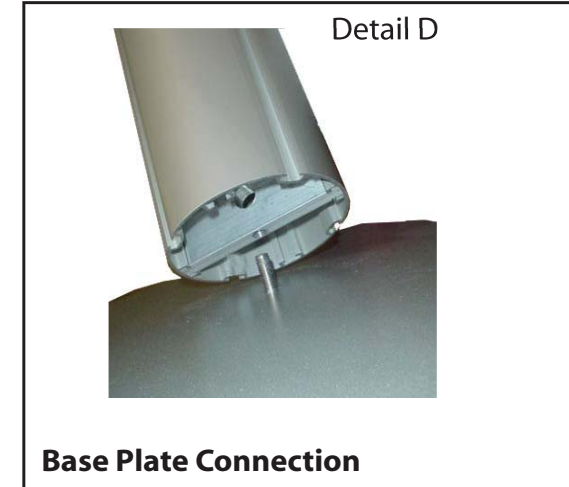

Detail D

Base Plate Connection

Attach base plate to round or square vertical extrusion using the bolt provided. Be careful not to strip the threads.

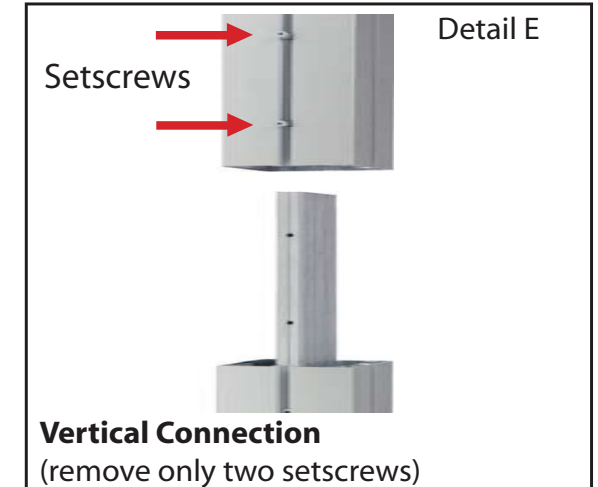

Detail E

Vertical Connection
(remove only two setscrews)

When vertical extrusions are packed in portable cases rather than crates or tubs, they must be broken down into smaller sections which then require assembly.

Remove only (2) setscrews when disassembling. Replace setscrews in extrusion after assembling it. Before packing, replace setscrews in extrusion to avoid losing them.

WHEN DISASSEMBLING ALUMINUM EXTRUSION, TIGHTEN ALL SETSCREWS AND LOCKS TO PREVENT LOSS DURING SHIPPING

866.652.2100

Lower Cube

Part Number	Qty for Step	Description
1	2	44.378" Horizontal extrusion w/ Locks and 2 - L Attachment
1A	4	44.378" Horizontal extrusion w/ Locks and 1 - L Attachment
1B	2	44.378" Horizontal extrusion w/ Locks, 2 - L Attachment and Pin
2	4	48"h Vertical extrusion and 2 - L Attachment

Lower Cube

Part Number	Qty for Step	Description
3	2	44.378" Horizontal extrusion w/ Locks and 2 - L Attachment
3A	4	44.378" Horizontal extrusion w/ Locks and 1 - L Attachment
3B	2	44.378" Horizontal extrusion w/ Locks, 2 - L Attachment and Pin
4	4	48"h Vertical extrusion and 2 - L Attachment

Upper Cube

Part Number	Qty for Step	Description
17	4	44.378" Horizontal extrusion w/ Locks and 2 - L Attachment
17A	4	44.378" Horizontal extrusion w/ Locks and 1 - L Attachment
18	4	48"h Vertical extrusion and 2 - L Attachment

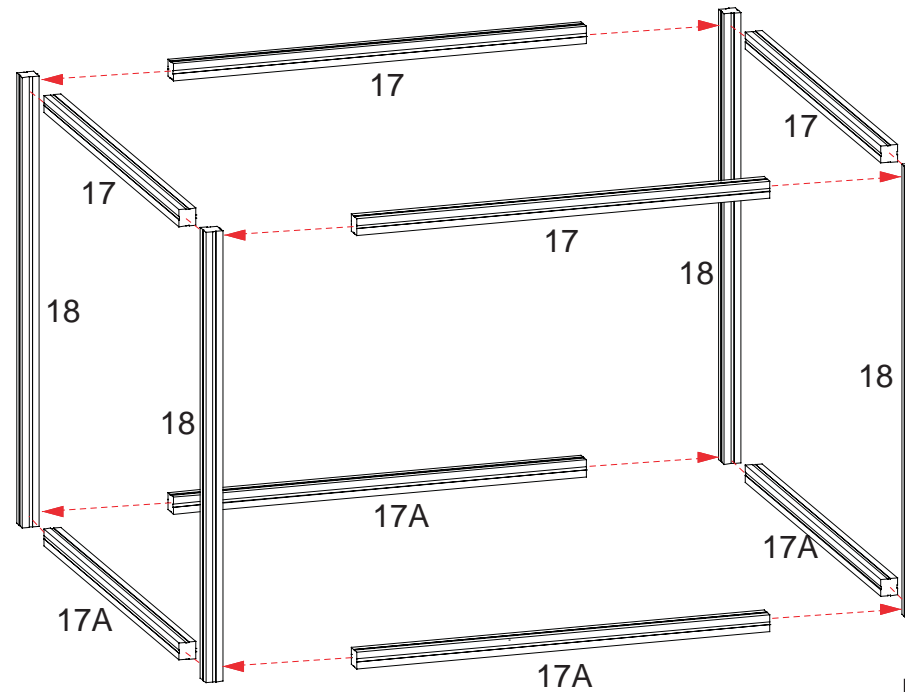
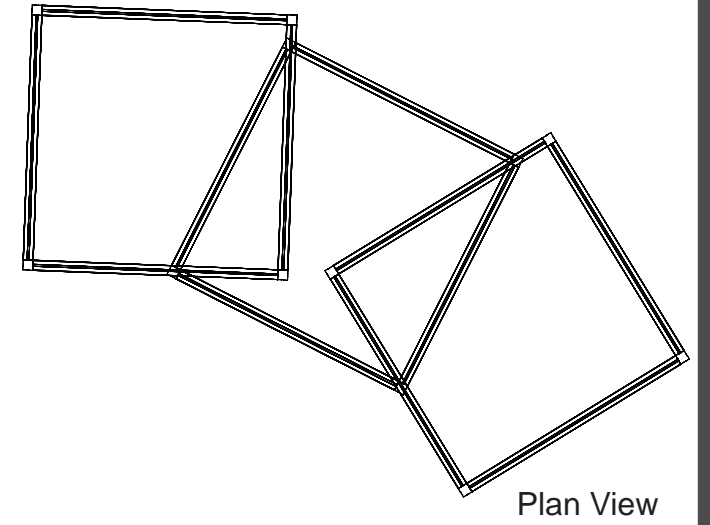

Steps

1) Assemble cubes by connecting horizontal extrusions between vertical extrusions as indicated.

Note: Velcro should face outward.

2) Set assembled upper cube atop lower cubes.

Note: Set corners atop pins.

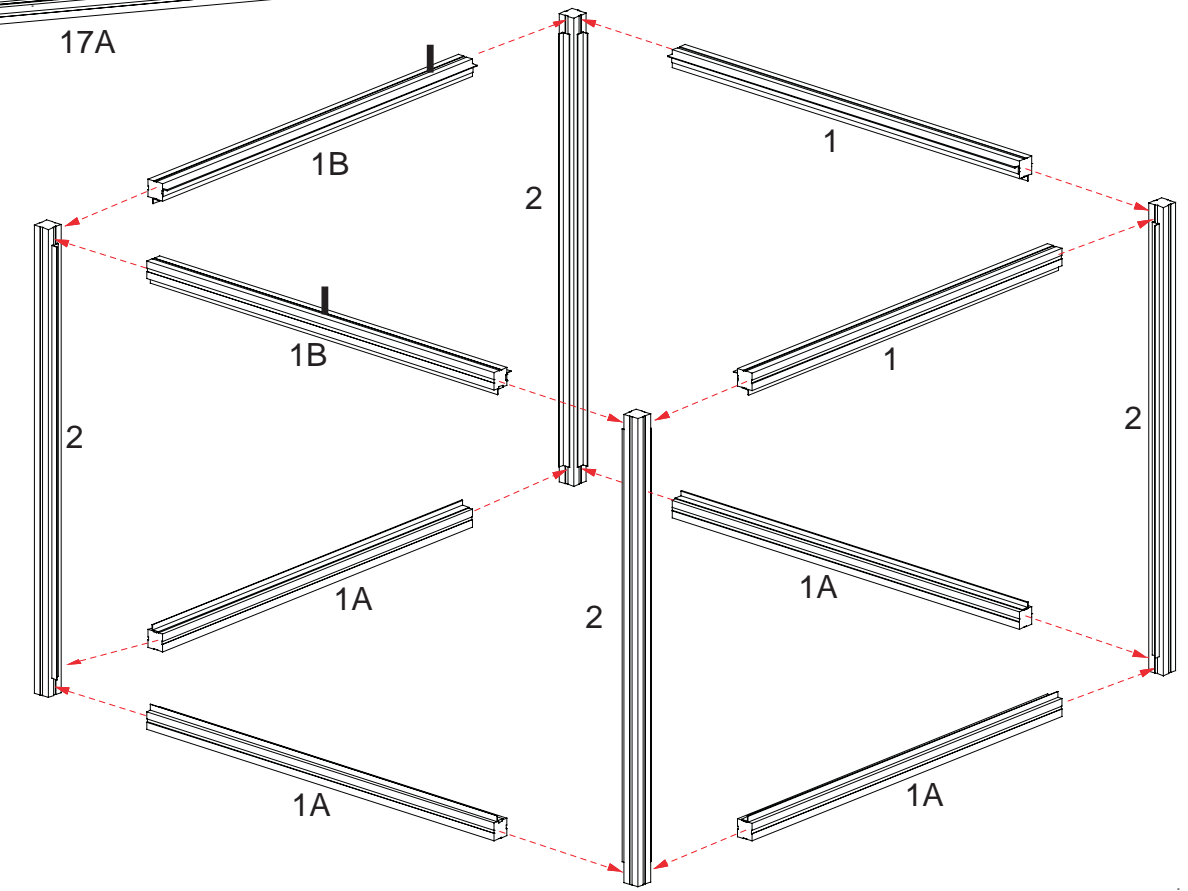
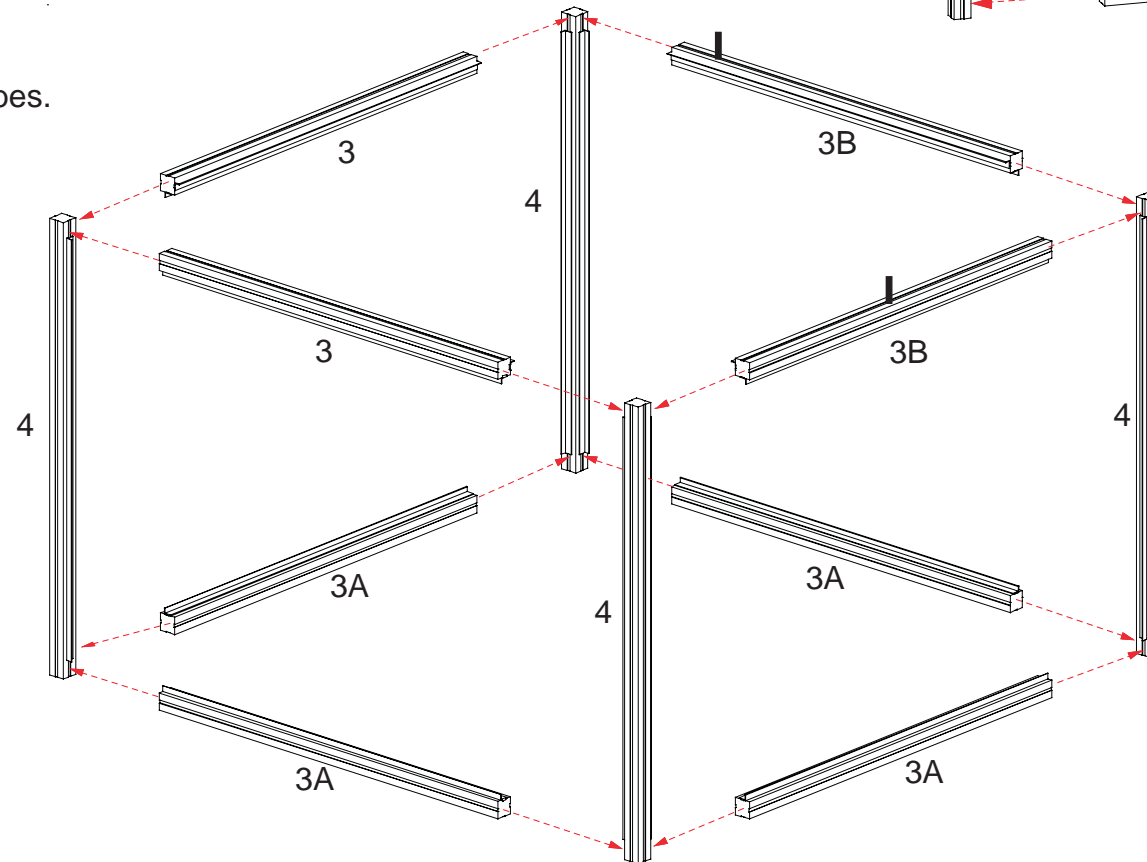

WHEN DISASSEMBLING ALUMINUM EXTRUSION, TIGHTEN ALL SETSCREWS AND LOCKS TO PREVENT LOSS DURING SHIPPING

866.652.2100

Lower Cube

Part Number	Qty for Step	Description
5	2	44.378" Horizontal extrusion w/ Locks and 2 - L Attachment
5A	4	44.378" Horizontal extrusion w/ Locks and 1 - L Attachment
5B	2	44.378" Horizontal extrusion w/ Locks, 2 - L Attachment and Pin
6	4	48"h Vertical extrusion and 2 - L Attachment

Lower Cube

Part Number	Qty for Step	Description
7	2	44.378" Horizontal extrusion w/ Locks and 2 - L Attachment
7A	4	44.378" Horizontal extrusion w/ Locks and 1 - L Attachment
7B	2	44.378" Horizontal extrusion w/ Locks, 2 - L Attachment and Pin
8	4	48"h Vertical extrusion and 2 - L Attachment

Upper Cube

Part Number	Qty for Step	Description
13	4	44.378" Horizontal extrusion w/ Locks and 2 - L Attachment
13A	4	44.378" Horizontal extrusion w/ Locks and 1 - L Attachment
14	4	48"h Vertical extrusion and 2 - L Attachment

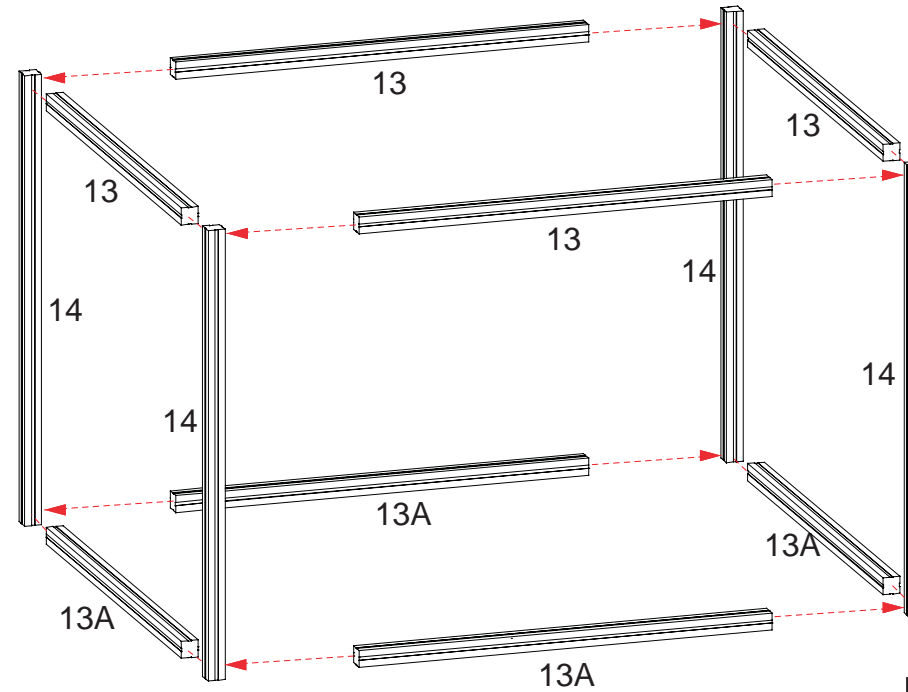
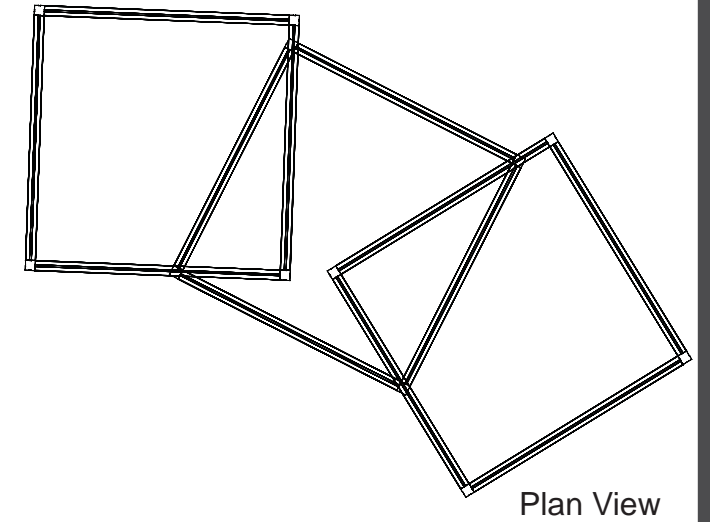

Steps

1) Assemble cubes by connecting horizontal extrusions between vertical extrusions as indicated.

Note: Velcro should face outward.

2) Set assembled upper cube atop lower cubes.

Note: Set corners atop pins.

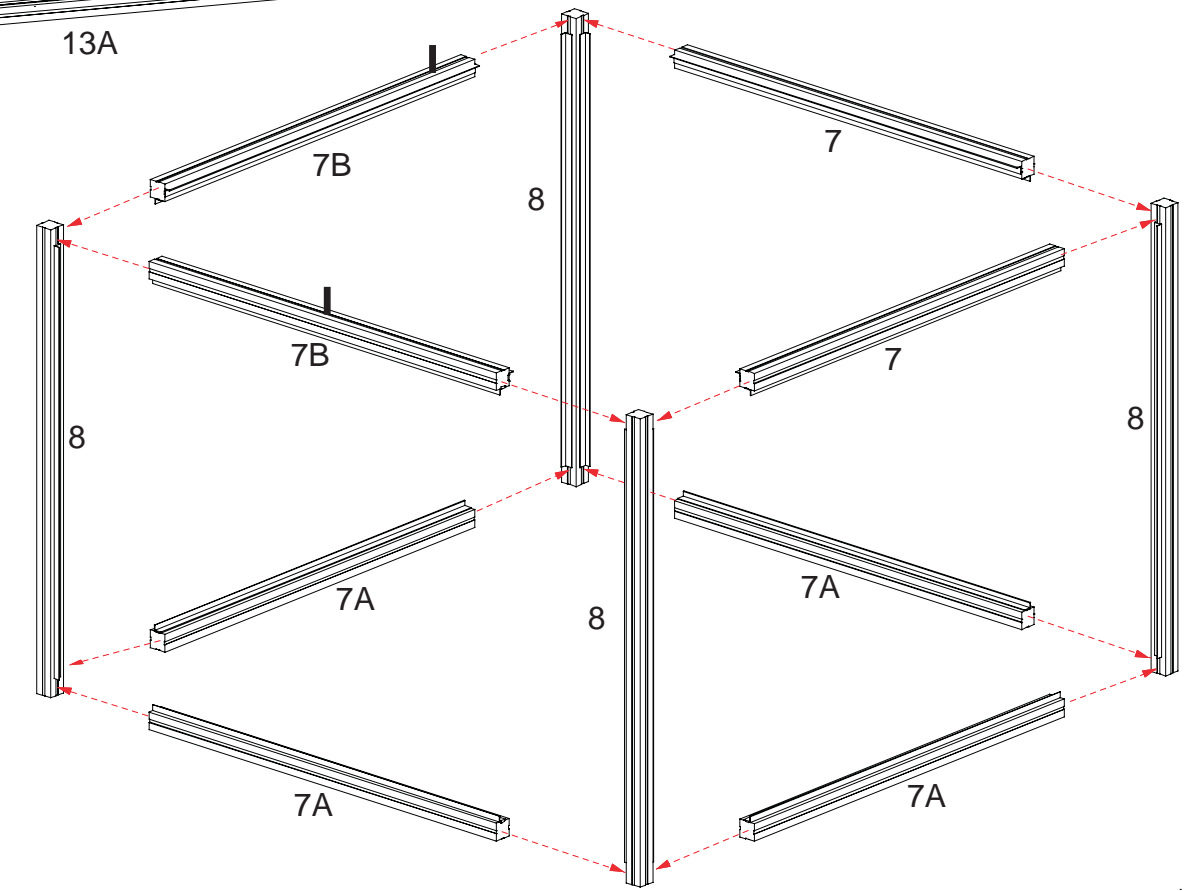
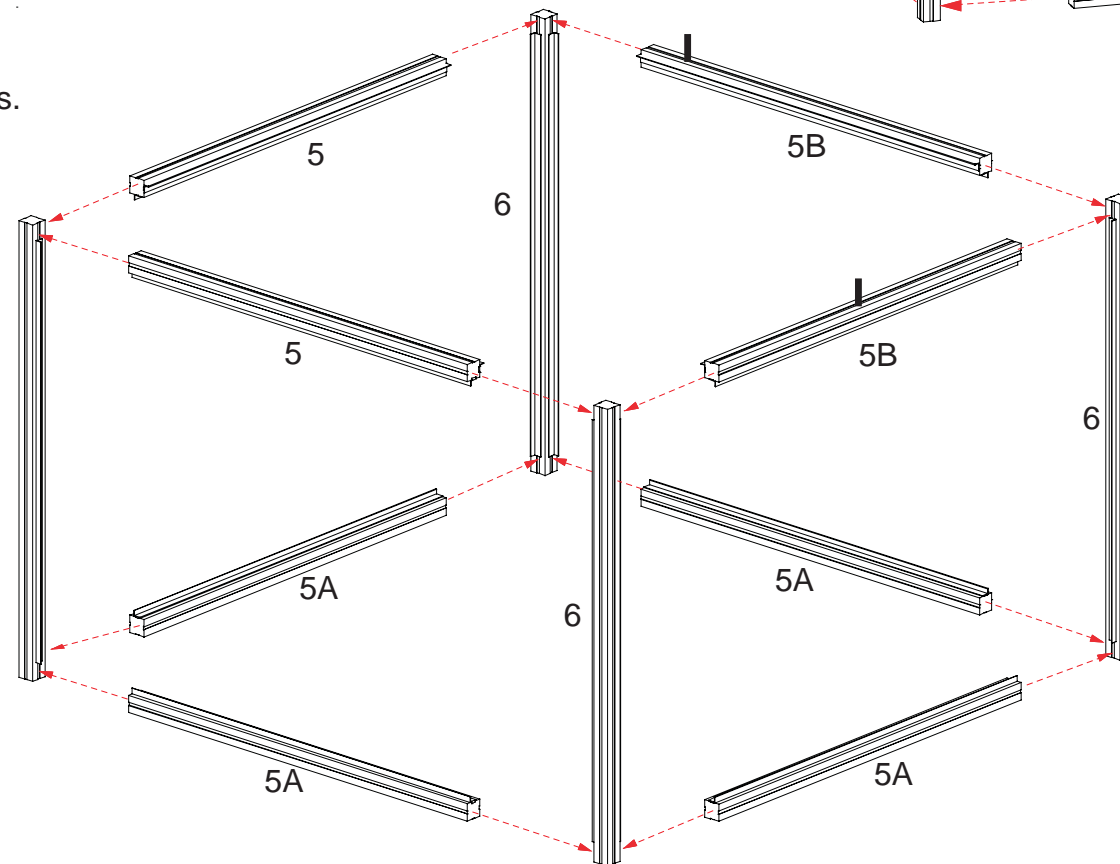

WHEN DISASSEMBLING ALUMINUM EXTRUSION, TIGHTEN ALL SETSCREWS AND LOCKS TO PREVENT LOSS DURING SHIPPING

866.652.2100

Lower Cube

Part Number	Qty for Step	Description
9	2	44.378" Horizontal extrusion w/ Locks and 2 - L Attachment
9A	4	44.378" Horizontal extrusion w/ Locks and 1 - L Attachment
9B	2	44.378" Horizontal extrusion w/ Locks, 2 - L Attachment and Pin
10	4	48"h Vertical extrusion and 2 - L Attachment

Lower Cube

Part Number	Qty for Step	Description
11	2	44.378" Horizontal extrusion w/ Locks and 2 - L Attachment
11A	4	44.378" Horizontal extrusion w/ Locks and 1 - L Attachment
11B	2	44.378" Horizontal extrusion w/ Locks, 2 - L Attachment and Pin
12	4	48"h Vertical extrusion and 2 - L Attachment

Upper Cube

Part Number	Qty for Step	Description
15	4	44.378" Horizontal extrusion w/ Locks and 2 - L Attachment
15A	4	44.378" Horizontal extrusion w/ Locks and 1 - L Attachment
16	4	48"h Vertical extrusion and 2 - L Attachment

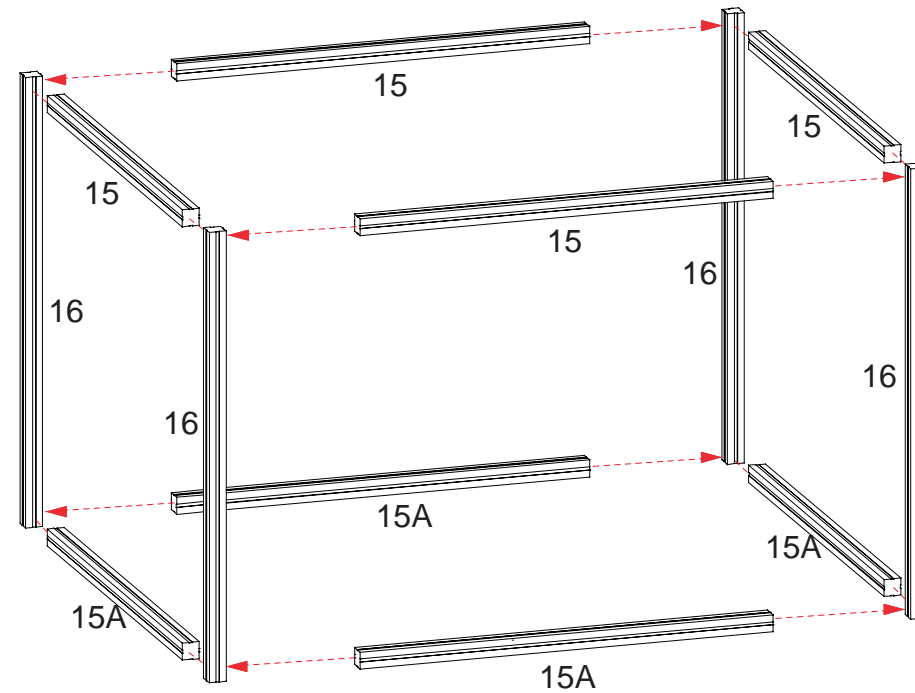
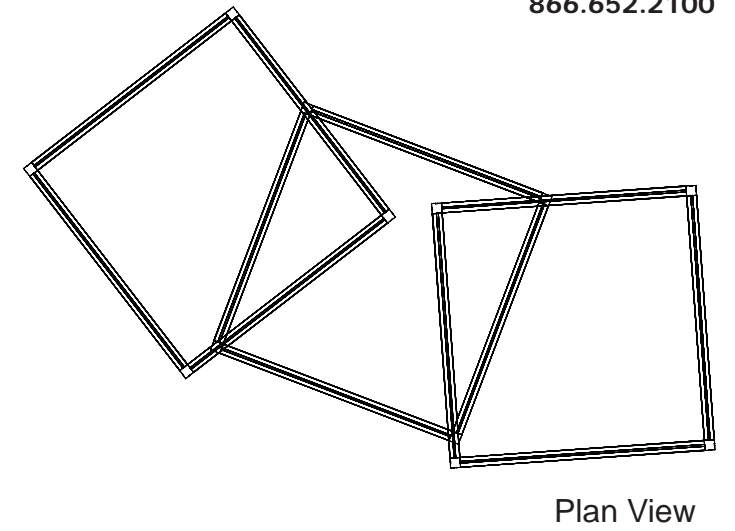

Steps

1) Assemble cubes by connecting horizontal extrusions between vertical extrusions as indicated.

Note: Velcro should face outward.

2) Set assembled upper cube atop lower cubes.

Note: Set corners atop pins.

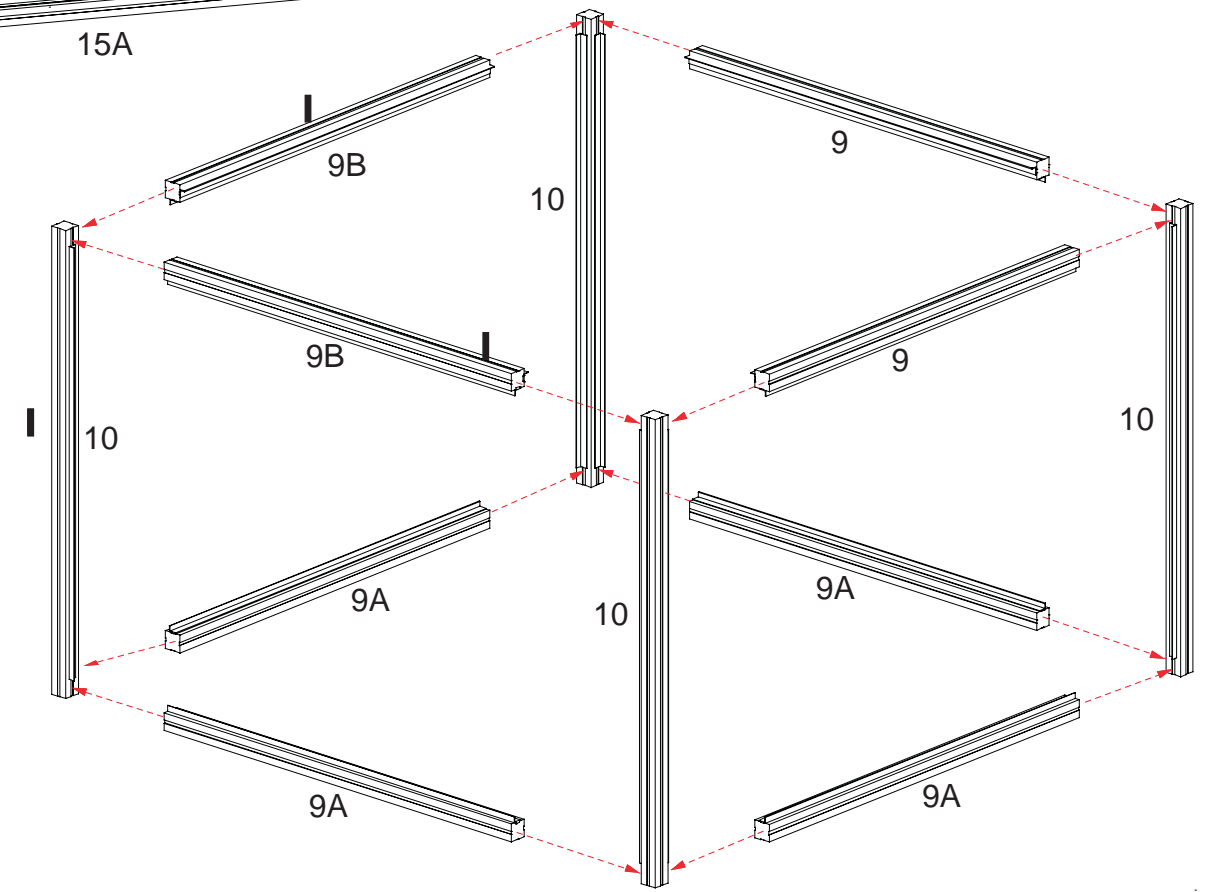
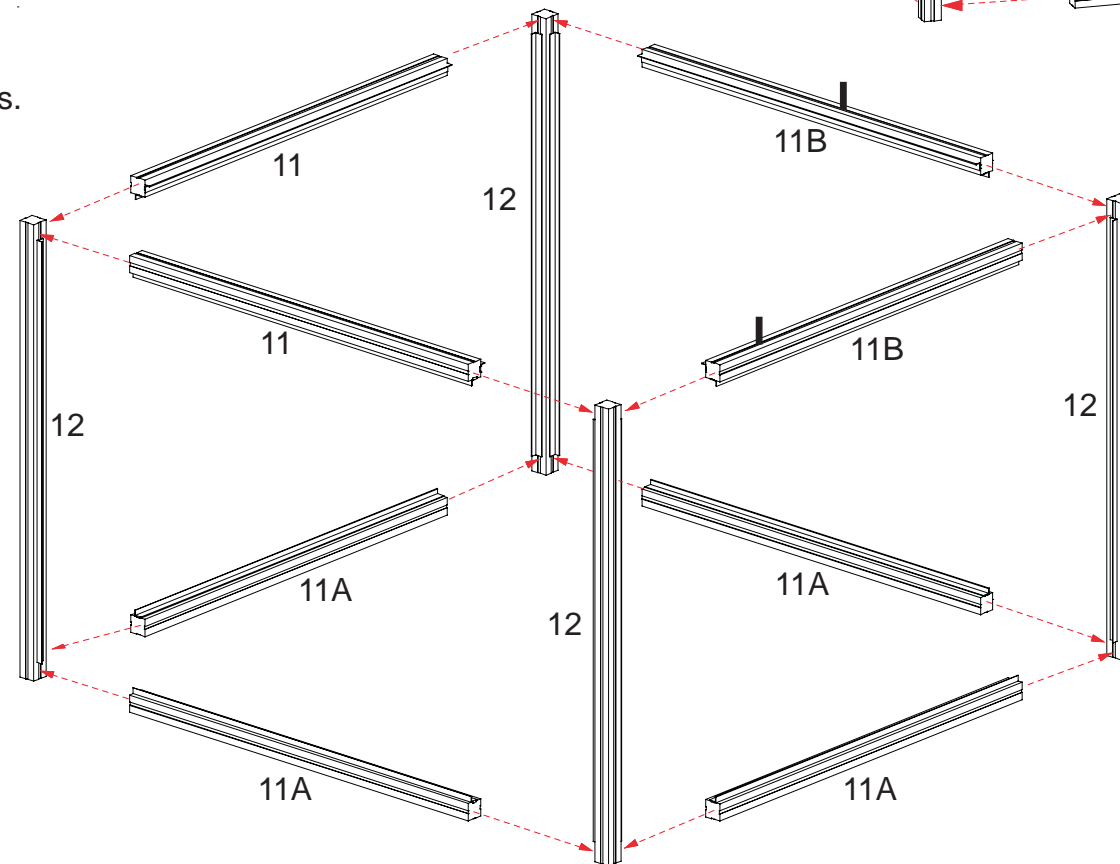

WHEN DISASSEMBLING ALUMINUM EXTRUSION, TIGHTEN ALL SETSCREWS AND LOCKS TO PREVENT LOSS DURING SHIPPING

866.652.2100

Part Number	Qty for Step	Description
19	4	92.417" Horizontal extrusion w/ Locks
20	4	96"h Vertical extrusion
21	4	92.417" Horizontal extrusion

Steps

- 1) Connect horizontal extrusions [xx] between vertical extrusions [xx] as shown below.
- 2) Connect upper horizontal extrusions [xx] between vertical extrusions [xx] as shown below.

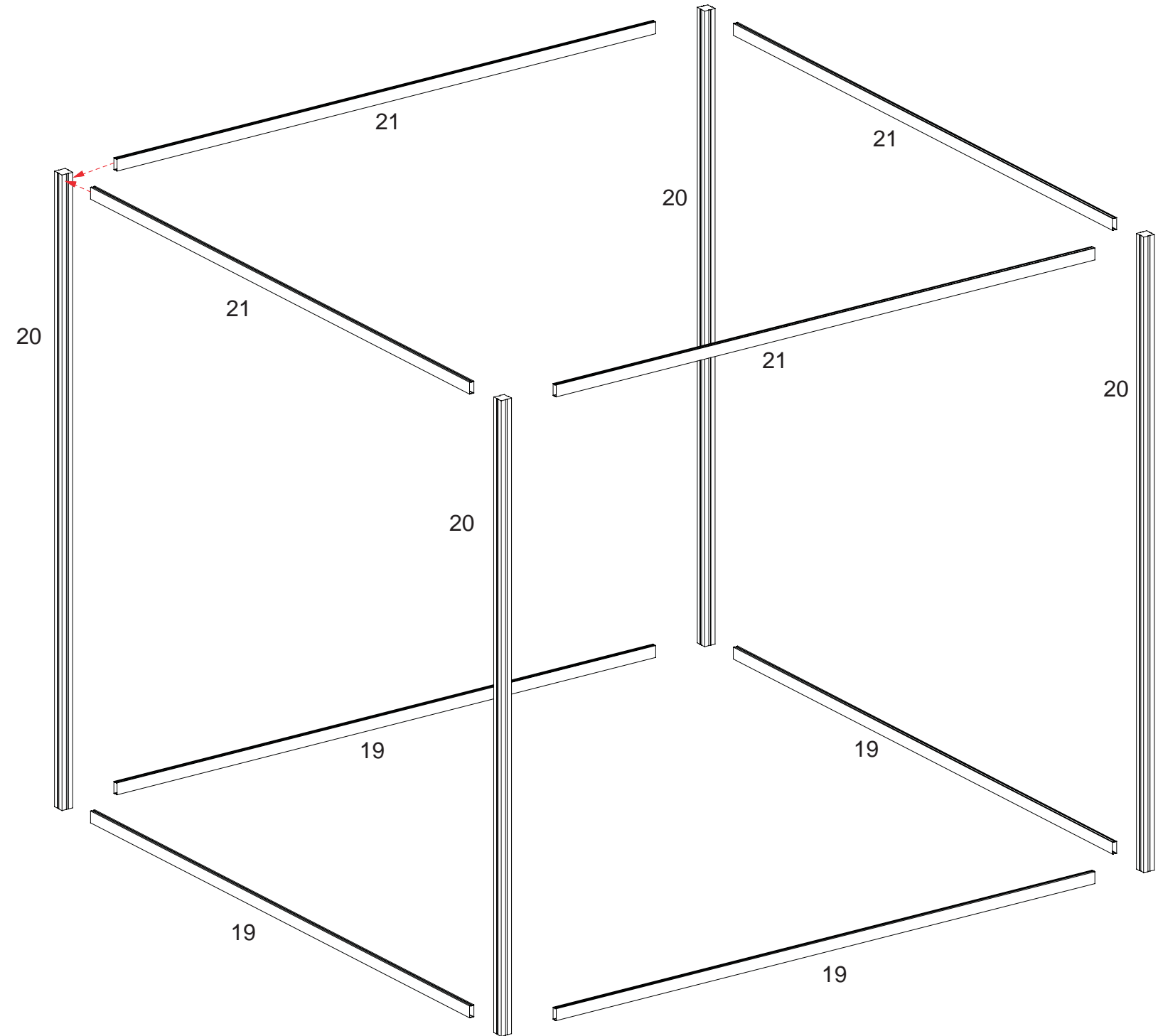

WHEN DISASSEMBLING ALUMINUM EXTRUSION, TIGHTEN ALL SETSCREWS AND LOCKS TO PREVENT LOSS DURING SHIPPING

Level 1

Item Number	Description
1	23"w x 38"h Flat Panel
2	47.5"h 90° Connector
3	30"w x 47.5"h Flat Panel
4	28.5"w x 47.5"h Flat Panel
5	30"w x 47.5"h Flat Panel
6	47.5"h 90° Connector
7	23"w x 38"h Flat Panel
8	38"h 90° Connector
9	30"w x 38"h Flat Panel w/ Door
10	28.5"w x 38"h Flat Panel w/ Door
11	30"w x 38"h Flat Panel w/ Door
12	38"h 90° Connector

Level 2

Item Number	Description
1	9.5"h End Cap
7	9.5"h End Cap

Modul Extrusion

Item	Qty.	Description
22	4	9.5"h Round Extrusion

Steps:

- 1) Assemble by starting at panel #1 and continue in numerical order.
- 2) Attach level 2 end caps to 90° corner [# 1 to 2 and 7 to 6] to 90° corner as shown.
- 3) Velcro internal shelf supports to inside of assembled base, then set internal shelf atop supports.
- 4) Attach L extrusion to panel #4 as indicated using thumbscrews.
- 5) Attach round extrusions [22] to top of counter, using supplied bolts as shown.
- 6) Place assembled counter atop assembled counter base and L extrusion.
- 7) Place upper shelf atop round extrusions and back panels as shown.

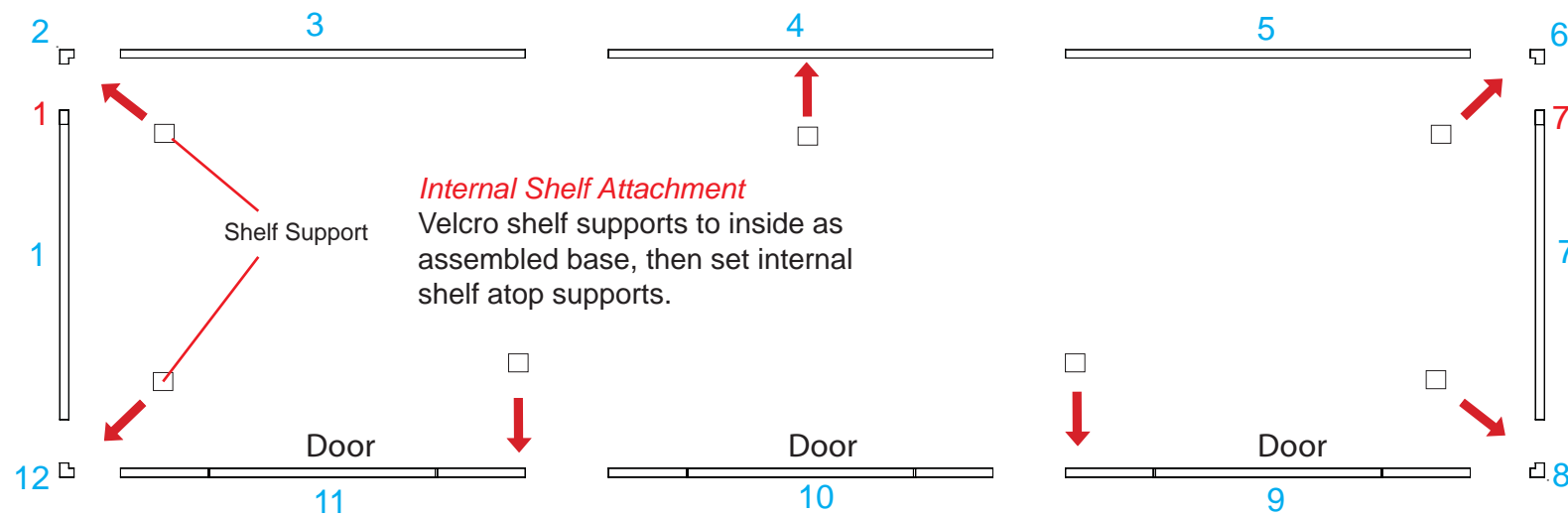
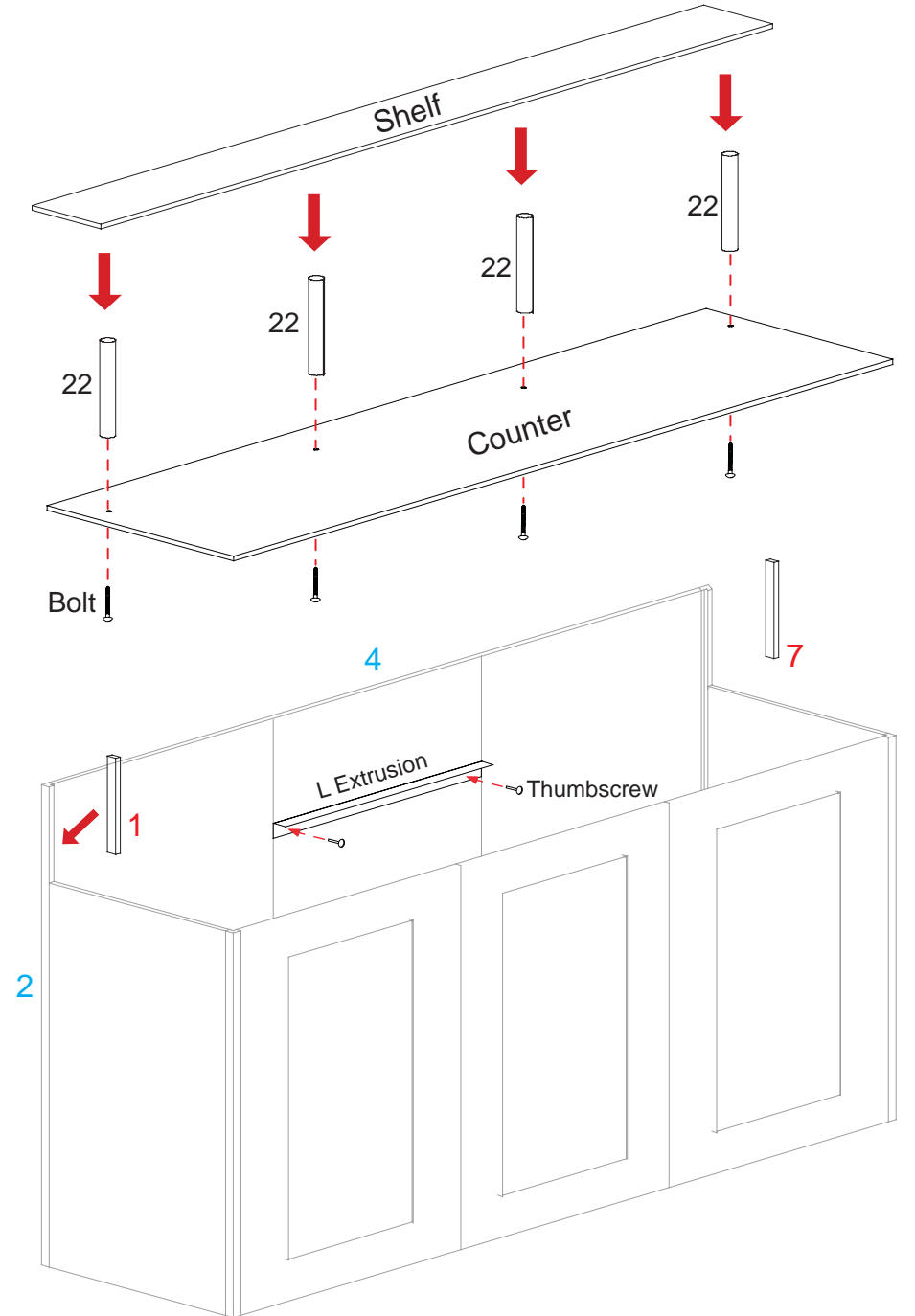

WHEN DISASSEMBLING ALUMINUM EXTRUSION, TIGHTEN ALL SETSCREWS AND LOCKS TO PREVENT LOSS DURING SHIPPING

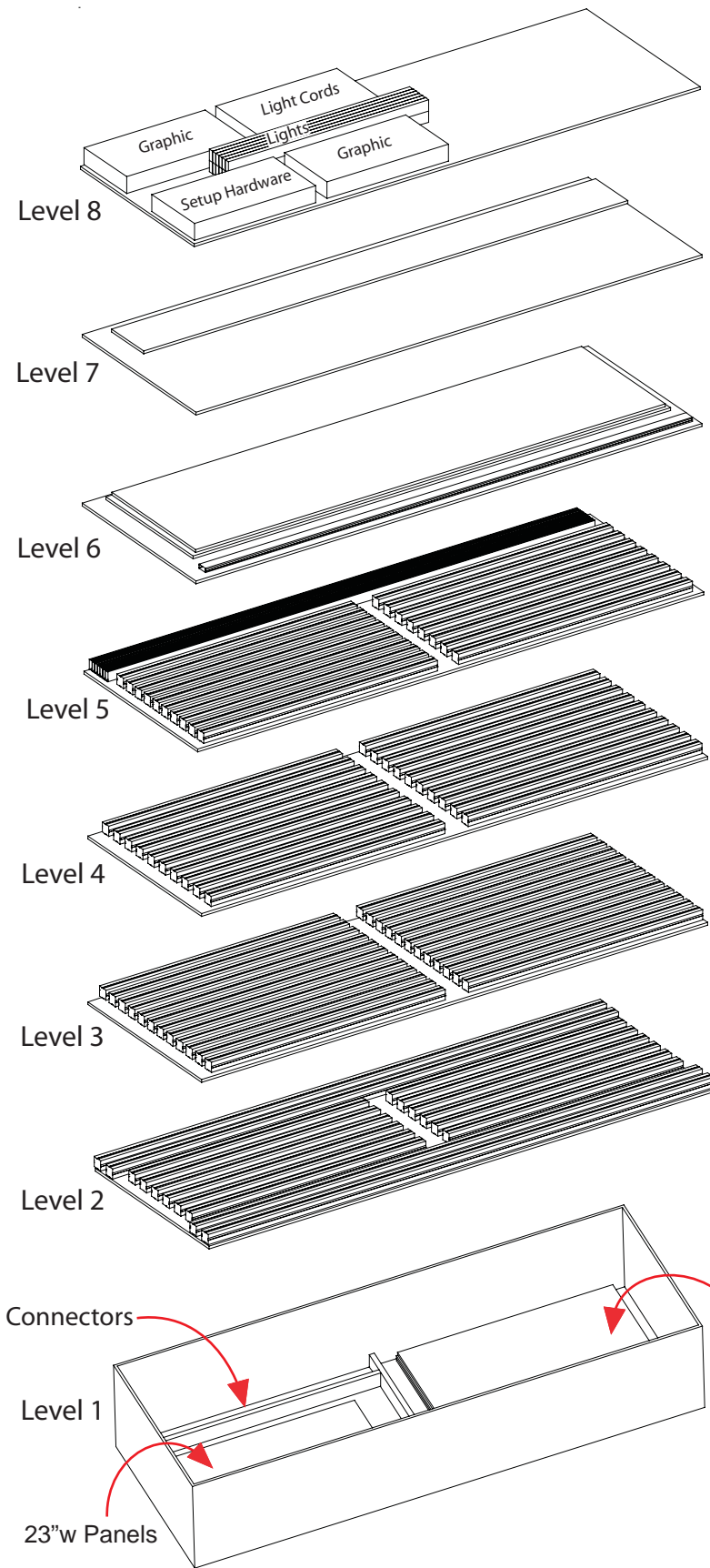

Level 7: Part List
- Upper Shelf

Level 6: Part List
- (1) 96\"/>

Level 5: Part List
- (7) 96\"/>

Level 4: Part List
- (20) 44.378\"/>

Level 3: Part List
- (24) 44.378\"/>

Level 2: Part List
- (2) 96\"/>

28.5\"/>



Level 7



Level 8



Setup Hardware



Level 4



Level 5



Level 6



Level 1



Level 2



Level 3

WHEN DISASSEMBLING ALUMINUM EXTRUSION, TIGHTEN ALL SETSCREWS AND LOCKS TO PREVENT LOSS DURING SHIPPING