

WHEN DISASSEMBLING ALUMINUM EXTRUSION, TIGHTEN ALL SETSCREWS AND LOCKS TO PREVENT LOSS DURING SHIPPING



Using Your Setup Instructions

The Euro LT Hybrids Setup Instructions are created specifically for your configuration. They are laid out sequentially in levels, including exploded views, and a logical series of detailed steps to assemble the main structure and components. We encourage you to study the instructions **before** attempting to assemble your exhibit.

Each page reminds you to tighten the setscrews after disassembling your exhibit to prevent loss of the locks and setscrews (see below in RED). This is VERY IMPORTANT.

Cleaning and Packing Your Display

- 1) Use care when cleaning aluminum extrusion or acrylic inserts. Use only non-abrasive cleaners.
- 2) When cleaning laminate inserts, countertops, or panels use mild cleansers and a soft material such as cotton.
- 3) Keep all display components away from extreme heat and long exposure to sunlight to avoid warping and fading.
- 4) Retain all packing material. It will make re-packing much easier and will reduce the likelihood of shipping damage.

General Setup Instructions for Extrusion System



The Tool

Most exhibits can be assembled with the supplied Hex Key Tool. Occasionally, a flat head screwdriver may be required.



Typical Connection

Most horizontal extrusion connections have a patented expandable lock. This lock inserts into the groove of an opposing extrusion. Tightening the lock with the Hex Key Tool expands the lock and creates a strong positive connection.



Typical Connection (cont'd)

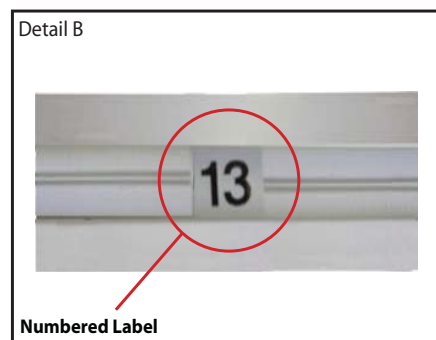

Numbered Label

Each extrusion contains a numbered label which corresponds with setup instructions. The label is located within a groove of the extrusion (when possible). With extrusion components the labels contain Black numbers unless otherwise specified.



Horizontal Inline Connection (remove only one setscrew)

Remove only (1) setscrew when disassembling. Replace setscrew in extrusion after assembling it. Before packing, replace setscrew in extrusion to avoid losing it.

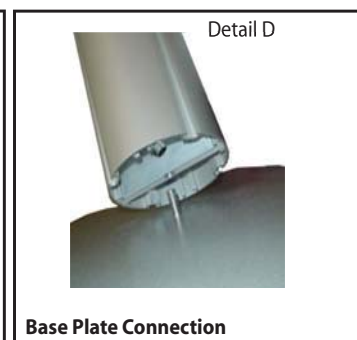

Base Plate Connection

Attach base plate to round or square vertical extrusion using the bolt provided. Be careful not to strip the threads.

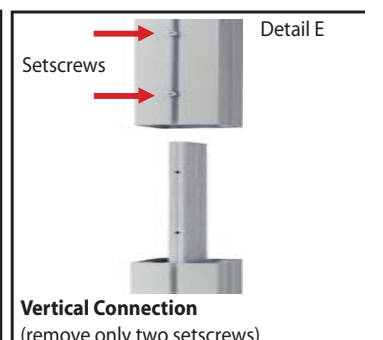

Vertical Connection (remove only two setscrews)

When vertical extrusions are packed in portable cases rather than crates or tubs, they must be broken down into smaller section which then require assembly.

Remove only (2) setscrews when disassembling. Replace setscrews in extrusion after assembling it. Before packing, replace setscrews in extrusion to avoid losing them.

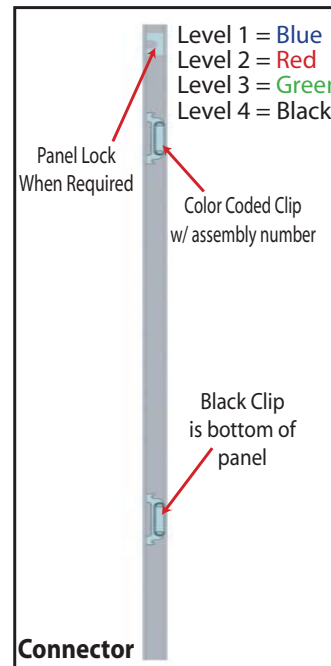

Connector

Each component has 2 clips, the lower clip is ALWAYS black. The top clip is color coded to distinguish which level. The color coded clip also contains the numbered label.

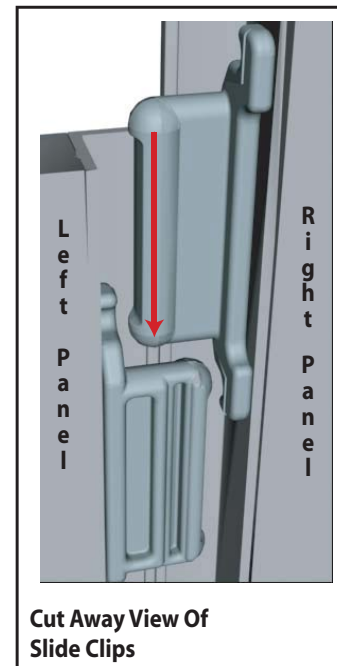

Cut Away View Of Slide Clips

Components connect together by aligning them and sliding downward connecting clips together.

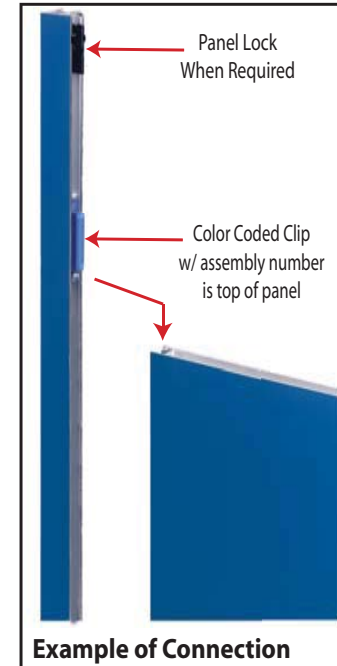

Example of Connection

Configurations are assembled from left to right, usually starting with #1 and following the numbered sequence.

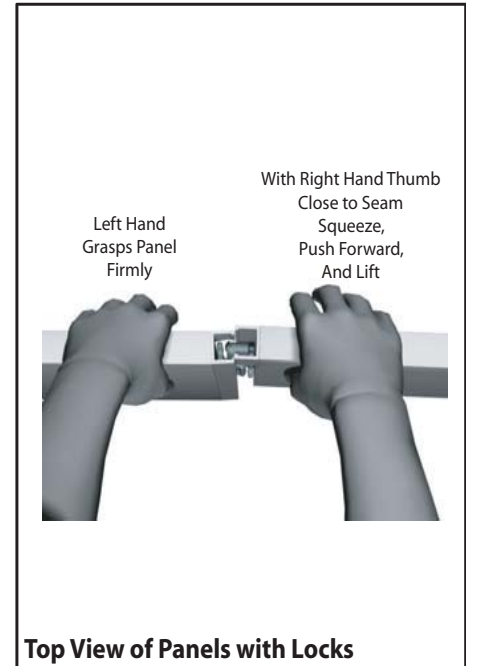

Top View of Panels with Locks

The first level of components contain panel locks that are located at the top of the panel for extra stability and seamless connection. When disassembling panels twist top connection slightly and lift right panel upward.

WHEN DISASSEMBLING ALUMINUM EXTRUSION, TIGHTEN ALL SETSCREWS AND LOCKS TO PREVENT LOSS DURING SHIPPING

866.652.2100

Item	Qty.	Description
1	2	Base Plate
1a	1	Base Plate w/ 2 Holes
2a/2b	1/1	48"h Vertical Extrusion
3a/3b	2/2	48"h 90° Corner Extrusion
4a/4b	1	47.875"h Round Vertical Extrusion
5a/5b	1	47.875"h Round Vertical Extrusion
6	1	Vertical Support Extrusion
7	1	Counter Support
8	1	47.9955"w Curved Extrusion
9	1	47.9955"w Curved Extrusion
10	1	40"w Horizontal Extrusion
11	1	40"w Horizontal Extrusion
12/12a	4/2	17.868"w Curved Extrusion

Steps:

- 1) Connect extrusions [2a to 2b, 3a to 3b, 4a to 4b and 5a to 5b] together.
- 1) Attach vertical vertical extrusion [5a/5b] to base plates [1] as shown, see detail D on general info page.
- 2) Attach vertical extrusion [4a/4b] and vertical support extrusion [6] to base plate [1a] as shown.
- 3) Attach curved horizontal extrusions [8 and 9] between vertical extrusions [2a/2b and 3a/3b] and horizontal extrusions [10 and 11] between vertical extrusions [3 and 5].
- 4) Attach curved horizontal extrusions [12] between vertical extrusions [3a/3b and 4a/4b], placing inserts [A].
- 5) Attach horizontal extrusions [7 and 7a] between vertical extrusions [4a and 6].
- 6) Attach counter top atop counter support and secure with thumbscrews to vertical extrusion [4a].
- 7) Apply graphics to assembled backwall

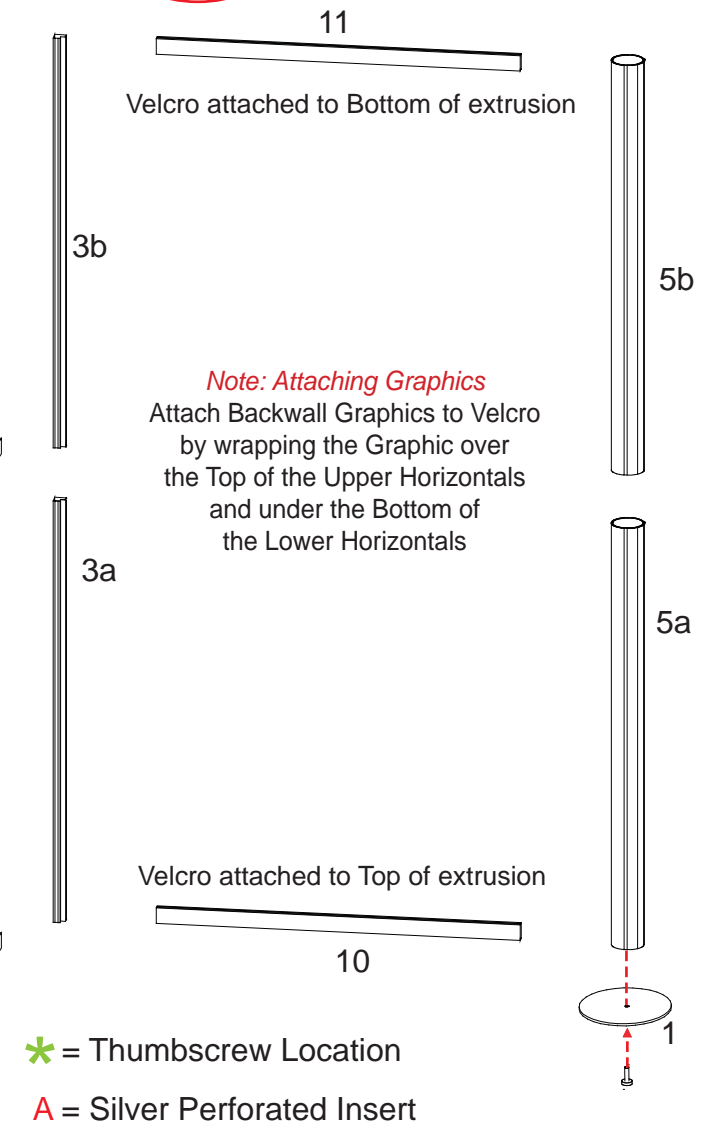
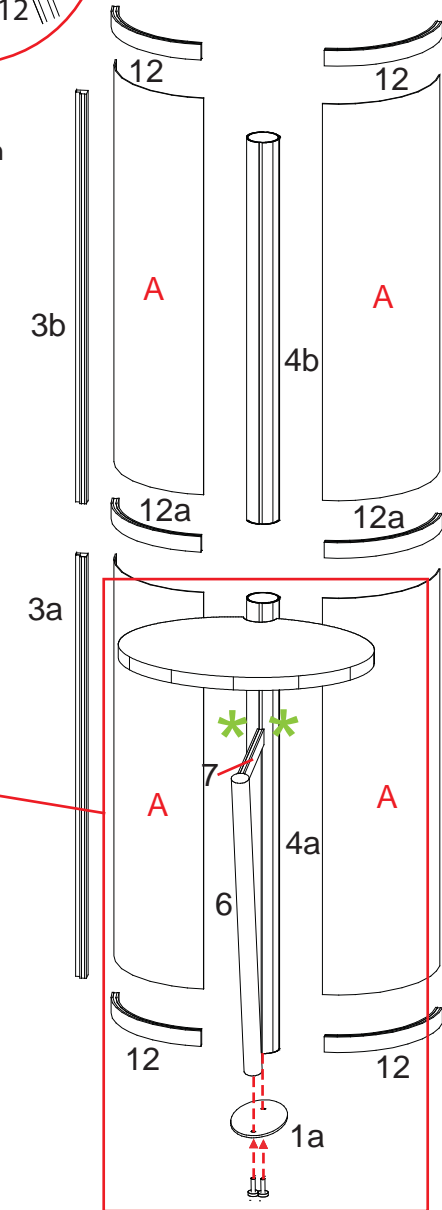
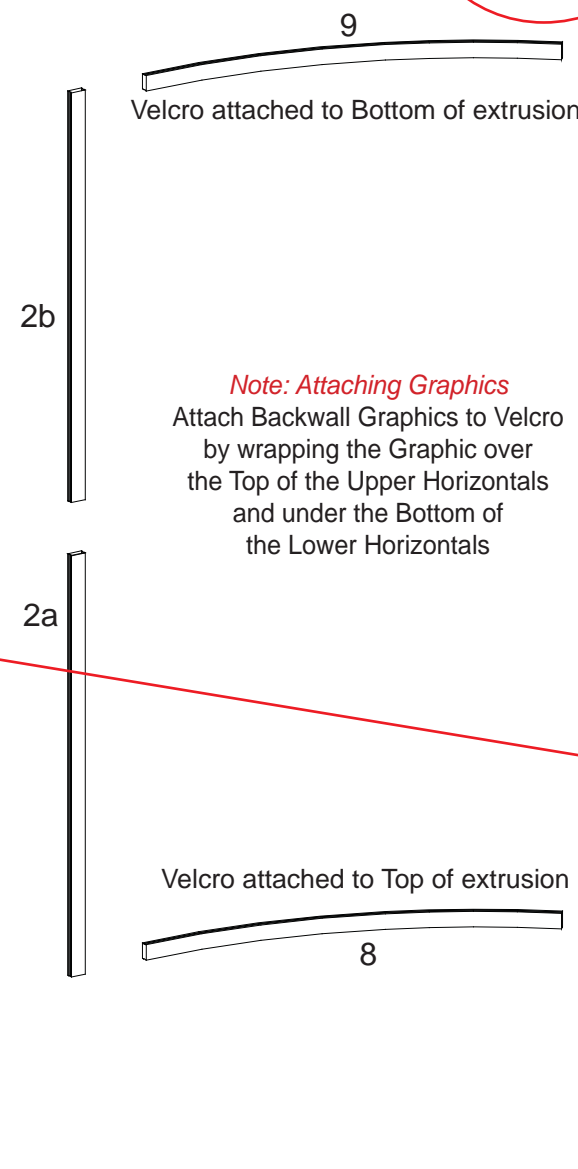
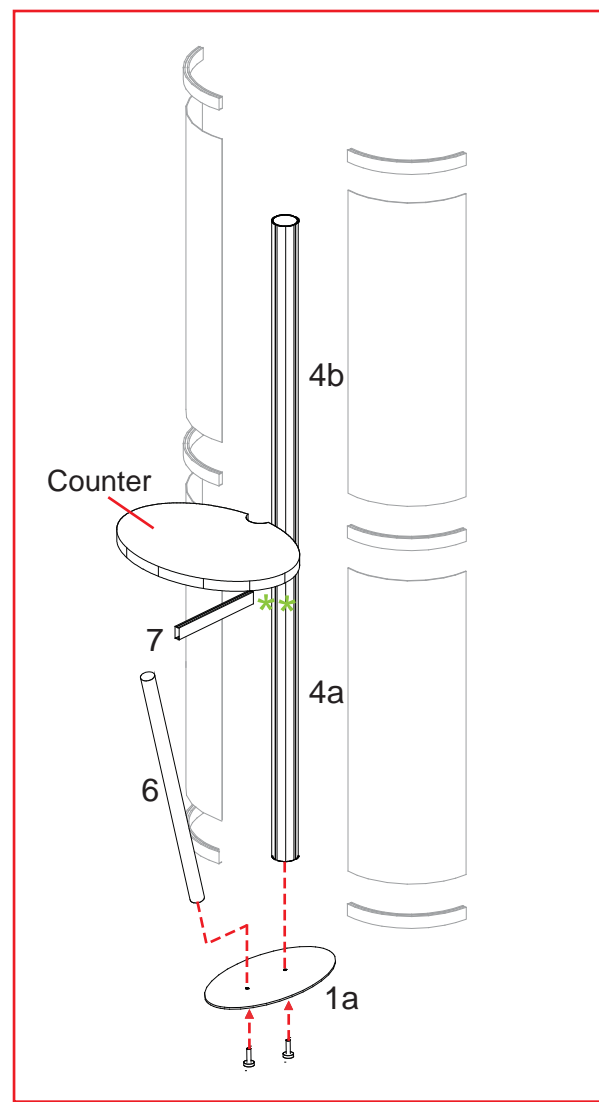
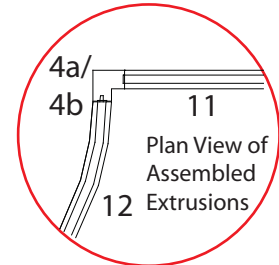
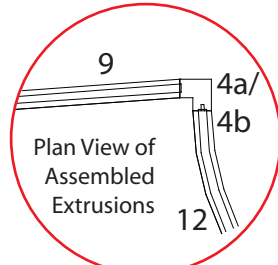
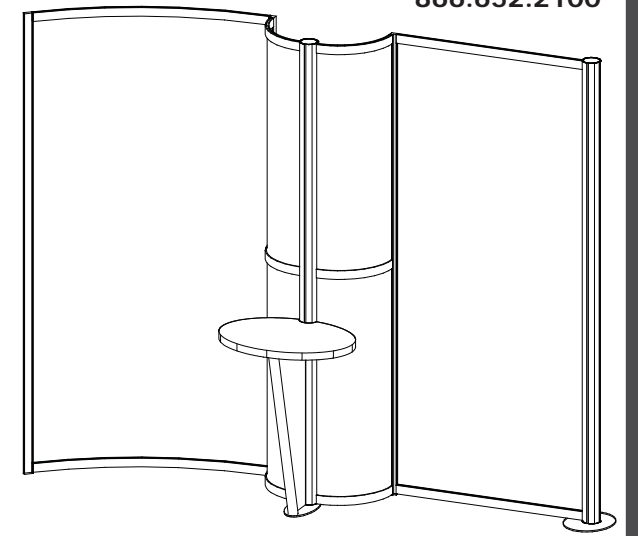

* = Thumbscrew Location
 A = Silver Perforated Insert

WHEN DISASSEMBLING ALUMINUM EXTRUSION, TIGHTEN ALL SETSCREWS AND LOCKS TO PREVENT LOSS DURING SHIPPING

Item	Qty.	Description
13a/13b	1	28.6"w Curved Horizontal Extrusion
14	2	11.418"h Vertical Extrusion
15a/15b	1	28.6"w Curved Horizontal Extrusion

Steps:

- 1) Connect curved pieces together [13a to 13b and 15a to 15b].
- 2) Assemble header by attaching vertical extrusions [14] between curve extrusions [13a/13b and 15a/15b] as shown.
- 3) Apply graphic to assembled header, then hook header to top of vertical extrusions [2 and 4].
- 4) Place finial to top of vertical as indicated.

Hook assembled frame to top of assembled backwall.

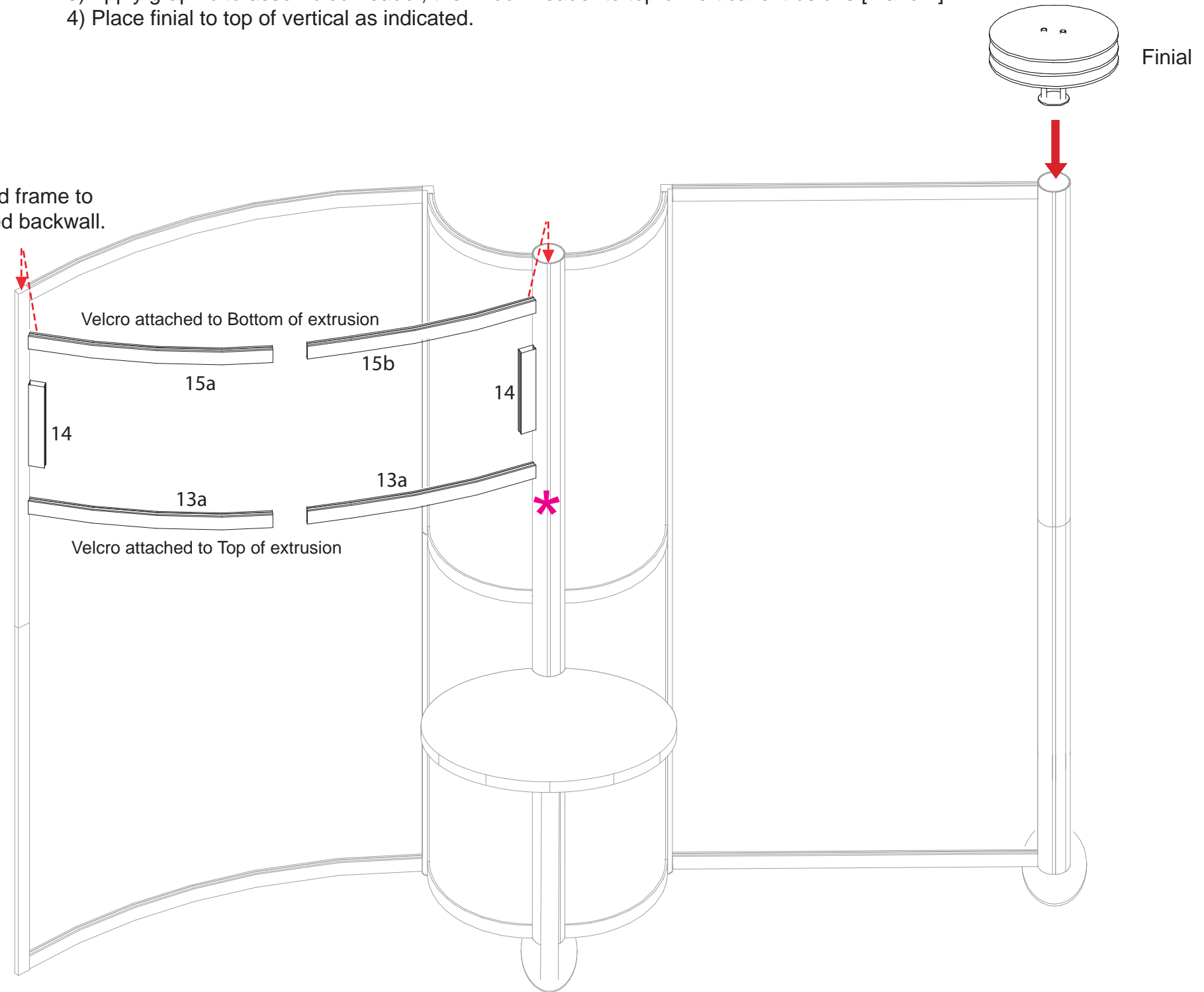

*** MONITOR MOUNT**
 Attach monitor mount to vertical extrusions after assembly.

Slide Mount into Groove of Vertical Extrusion. Tighten Setscrew. Attach top Plate and tighten screws.

WHEN DISASSEMBLING ALUMINUM EXTRUSION, TIGHTEN ALL SETSCREWS AND LOCKS TO PREVENT LOSS DURING SHIPPING

866.652.2100

Setup Instructions:

- A) Use standoff screws to secure the front panel with door and back panel of the pedestal to the side panels.
- B) After assembling front, back, and side panels, slide floor into the bottom of the pedestal. The floor will sit on pins on the inside of the side panels.
- C) After floor is in place, use velcro attachments to install shelf.

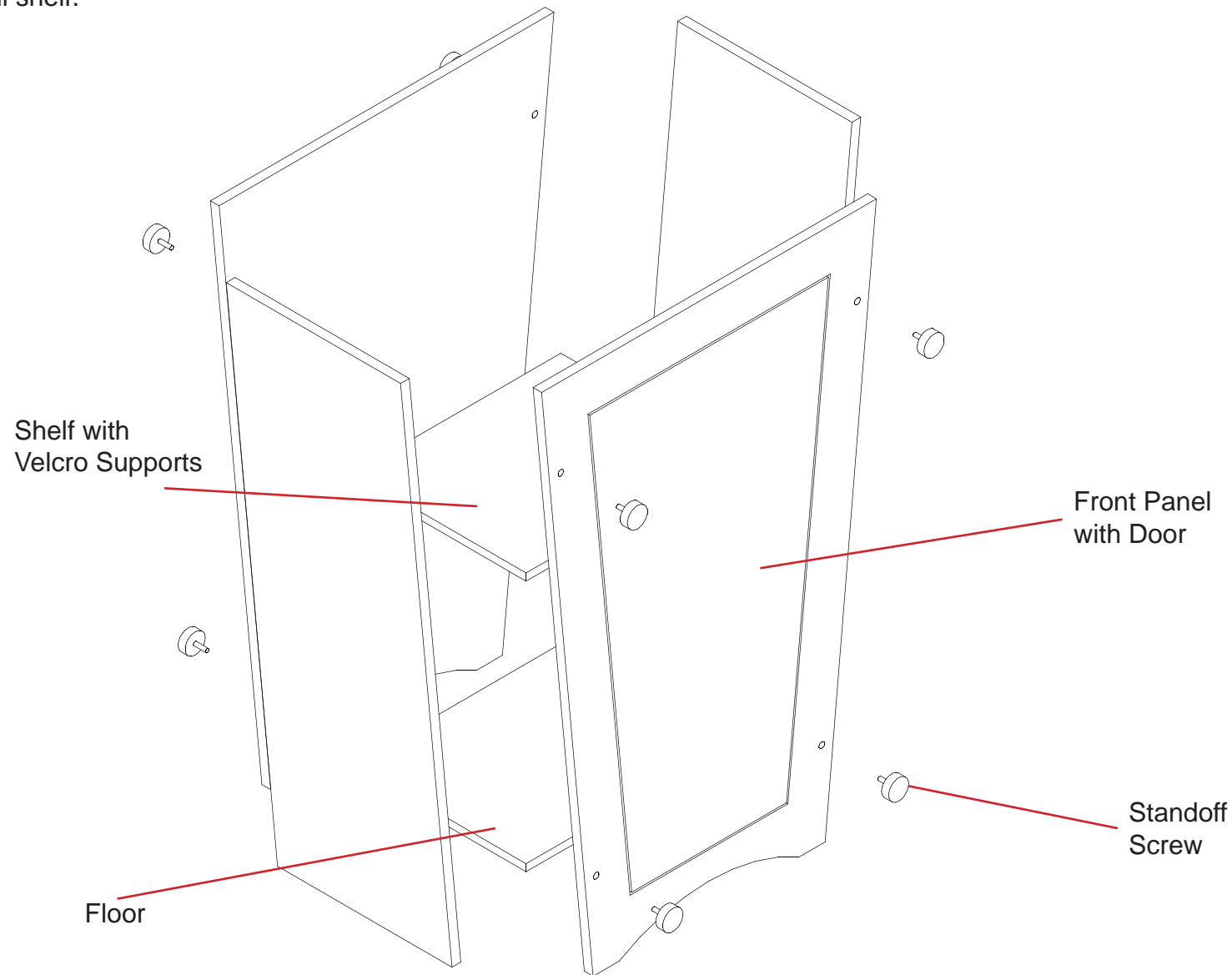
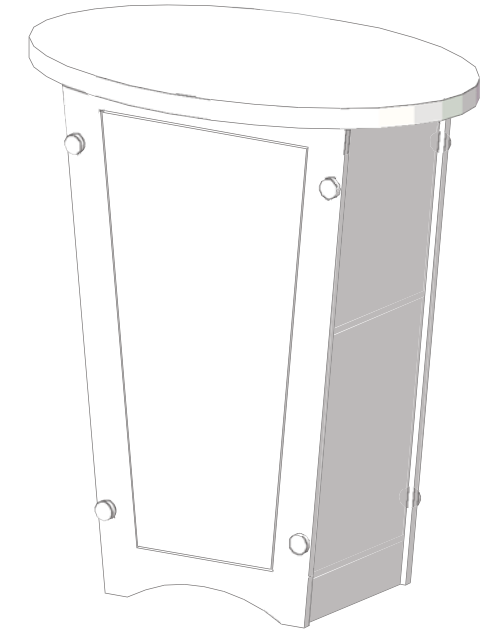

Attach the oval counter top to the pedestal base.

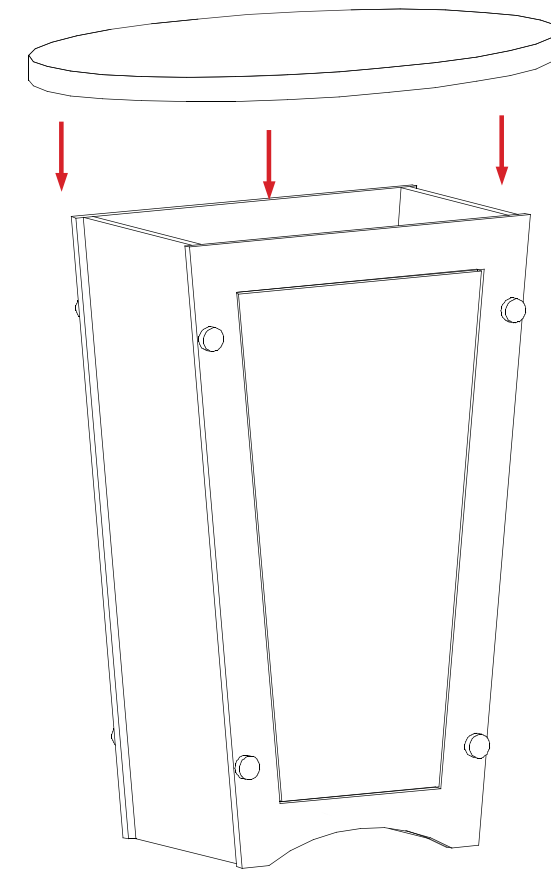

WHEN DISASSEMBLING ALUMINUM EXTRUSION, TIGHTEN ALL SETSCREWS AND LOCKS TO PREVENT LOSS DURING SHIPPING

Case 1 of 5

Item List:

- Pedestal Components
- Set-up Hardware Box
 - Counter Support
 - Pins
 - Stand-off Screw Caps
 - Monitor Mount

Case 2 of 5

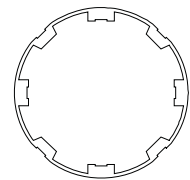

47.875" Round Extrusion
Qty. : 2

Case 3 of 5

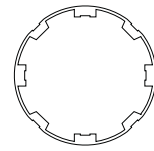

47.875" Round Extrusion
Qty. : 2

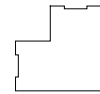

48" Corner Extrusion
Qty. : 4



48" Extrusion
Qty. : 2



47.99" Curved Extrusion
Qty. : 2



40" Curved Extrusion
Qty. : 2



Counter Support Extrusion
Qty. : 1

Case 4 of 5



17.868" Curved Extrusion
Qty. : 6

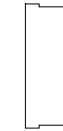

Header Extrusions

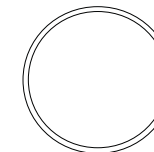

Vertical Support Extrusion
Qty. : 1

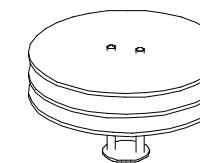

Finial
Qty. : 1

Case 5 of 5

Item List:

- (4) Perf Metal Insert
- Graphics

WHEN DISASSEMBLING ALUMINUM EXTRUSION, TIGHTEN ALL SETSCREWS AND LOCKS TO PREVENT LOSS DURING SHIPPING