

WHEN DISASSEMBLING ALUMINUM EXTRUSION, TIGHTEN ALL SETSCREWS AND LOCKS TO PREVENT LOSS DURING SHIPPING

visionary™ IDESIGNS

Using Your Setup Instructions

The Visionary Designs Setup Instructions are created specifically for your configuration. They are laid out sequentially, including an exploded view of the entire display, and then a logical series of detailed steps to assemble the main structure and components. We encourage you to study the instructions **before** attempting to assemble your exhibit.

Each page reminds you to tighten the setscrews after disassembling your exhibit to prevent loss of the locks and setscrews (see below in RED). This is **VERY IMPORTANT**.

Cleaning and Packing Your Display

- 1) Use care when cleaning aluminum extrusion or acrylic inserts. Use only non-abrasive cleaners.
- 2) When cleaning laminate inserts or countertops, use mild cleansers and a soft material such as cotton.
- 3) Keep all display components away from extreme heat and long exposure to sunlight to avoid warping and fading.
- 4) Retain all packing material. It will make re-packing much easier and will reduce the likelihood of shipping damage.



The Tool

Most Visionary Designs exhibits can be assembled with the supplied Hex Key Tool. Occasionally, a flat head screwdriver may be required.



Typical Connection

Most horizontal extrusion connections have a patented expandable lock. This lock inserts into the groove of an opposing extrusion. Tightening the lock with the Hex Key Tool expands the lock and creates a strong positive connection.



Typical Connection (cont'd)



Numbered Label

Each extrusion contains a numbered label which corresponds with setup instructions. The label is located within a groove of the extrusion (when possible). With Visionary Designs the labels contain Black numbers unless otherwise specified.



Horizontal Inline Connection (remove only one setscrew)

Remove only (1) setscrew when disassembling. Replace setscrew in extrusion after assembling it. Before packing, replace setscrew in extrusion to avoid losing it.

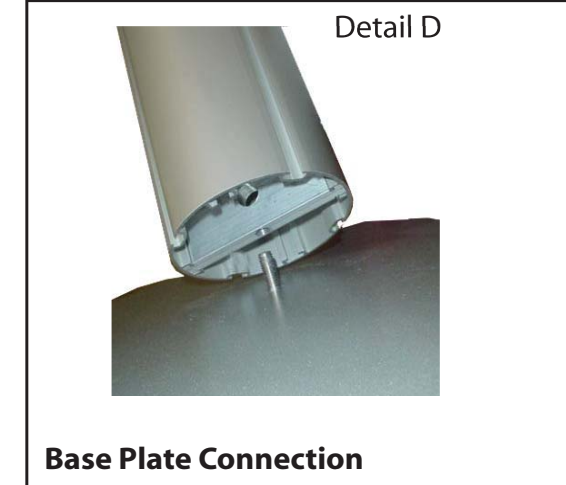

Base Plate Connection

Attach base plate to round or square vertical extrusion using the bolt provided. Be careful not to strip the threads.

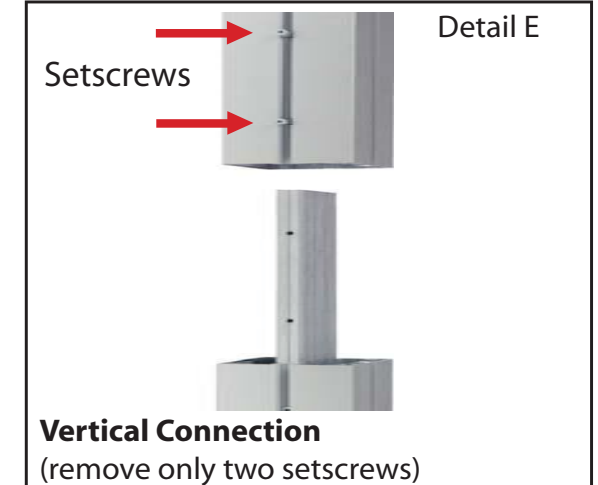

Vertical Connection
(remove only two setscrews)

When vertical extrusions are packed in portable cases rather than crates or tubs, they must be broken down into smaller sections which then require assembly.

Remove only (2) setscrews when disassembling. Replace setscrews in extrusion after assembling it. Before packing, replace setscrews in extrusion to avoid losing them.

WHEN DISASSEMBLING ALUMINUM EXTRUSION, TIGHTEN ALL SETSCREWS AND LOCKS TO PREVENT LOSS DURING SHIPPING

Part Number	Qty for Step	Description
1	2	Base Plates
2	2	42" h Lower Vertical extrusion
2a	2	Extrusion w/ Velcro Attached to Back of member
3	2	42" h Upper Vertical extrusion
3a	2	Extrusion w/ Velcro Attached to Back of member
4a/4b	1/1	42" Lower Formed Horizontal w/ Velcro attached to Back of member
5a/5b	1/1	42" Middle Formed Horizontal w/ Velcro attached to Back of member

Steps

- 1) Attach vertical extrusions [2] and 40" to the oval base plates [1], see detail D on general information page.
- 2) Place upper vertical extrusions [3] atop of lower vertical extrusions [2].
- 3) Assemble all horizontal extrusions together [4a to 4b and 5a to 5b].
- 4) Attach lower horizontal assemblies [4a/4b] between vertical assemblies [2 and 3] as shown.
NOTE: Velcro on Lower Horizontals must face BACKWARD.
- 5) Attach upper horizontal assemblies [5a/5b] between vertical assemblies [2 and 3] as shown.
NOTE: Velcro on Upper Horizontals must face BACKWARD.
- 6) Connect extrusions [2a and 3a] together.
- 7) Attach extrusion assemblies [2a/3a] between horizontal extrusions [4a/4b and 5a/5b] as shown.

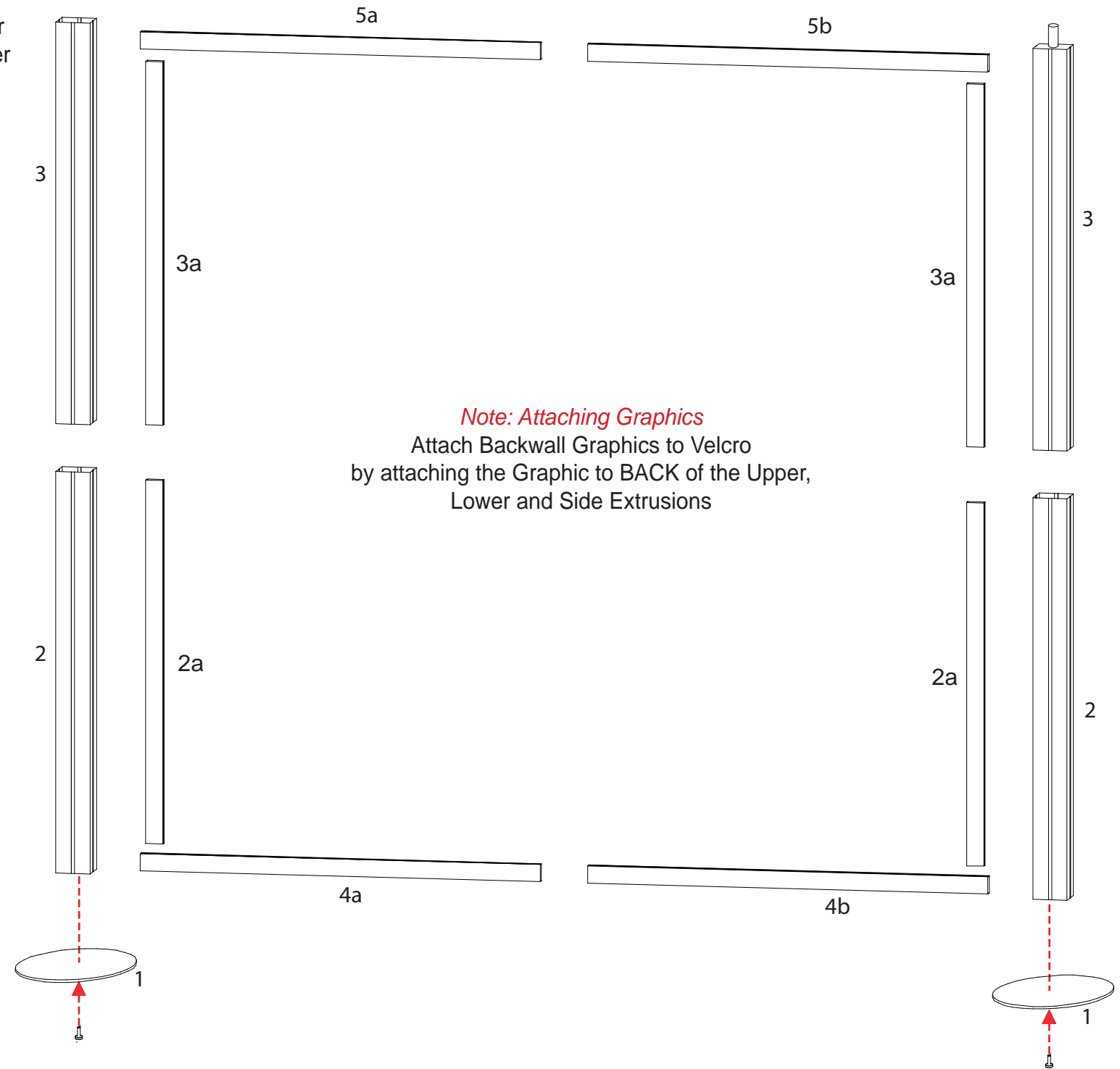

WHEN DISASSEMBLING ALUMINUM EXTRUSION, TIGHTEN ALL SETSCREWS AND LOCKS TO PREVENT LOSS DURING SHIPPING

866.652.2100

Wing Attachment

Slide A10 Clamp into groove of square extrusion.



When desired location is found, tighten set screw to secure.



Tighten black plastic set screw to secure Wing in place.



A10

Set-Screw

Black Plastic Set-screw

Light Connection

Attach Lights to Backwall where desired and tighten in place.

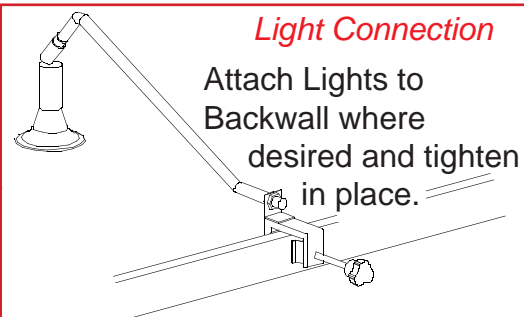
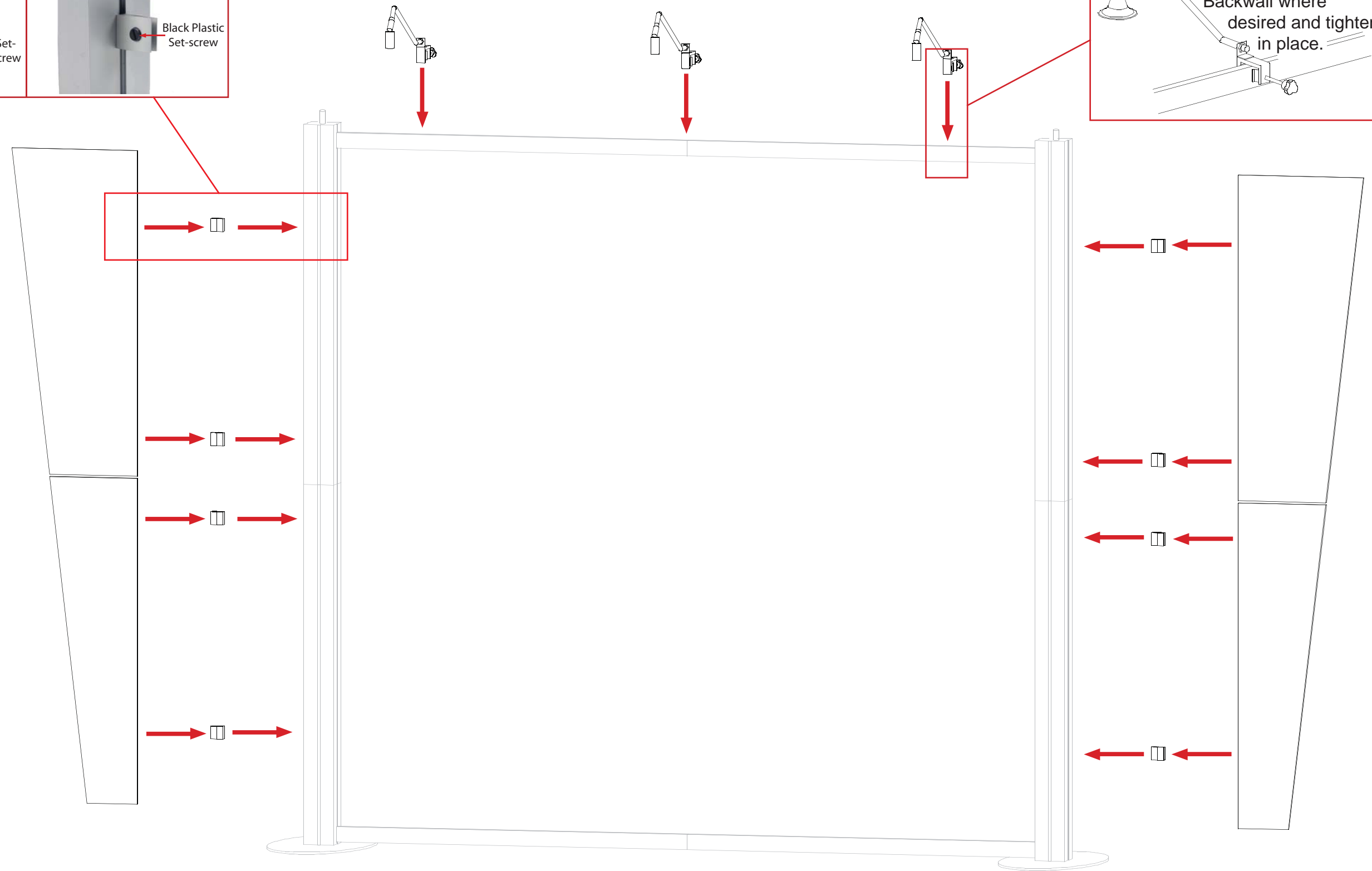
WHEN DISASSEMBLING ALUMINUM EXTRUSION, TIGHTEN ALL SETSCREWS AND LOCKS TO PREVENT LOSS DURING SHIPPING



Using Your Setup Instructions

The Aero Overhead Sign Setup Instructions are created specifically for your configuration. They include an exploded view of the frame which is sequentially numbered. We encourage you to study the instructions before attempting to assemble your exhibit.

Connections are kept very simple: no tools. Everything assembles with push-button connectors and pre-connected horizontal sections.

Cleaning and Packing Your Display

- 1) Use care when cleaning aluminum extrusion or acrylic inserts. Use only non-abrasive cleaners.
- 2) Retain all packing material. It will make re-packing much easier and will reduce the likelihood of shipping damage.

- Steps:
- 1) Connect canopy pieces together as shown.
 - 2) Apply pillow case graphic to assembled canopy

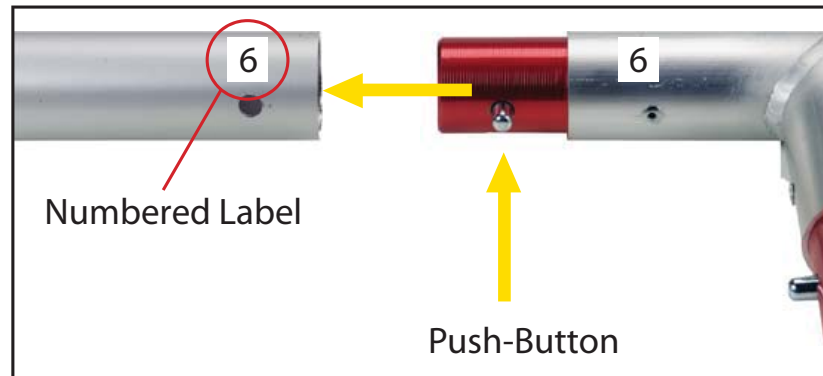
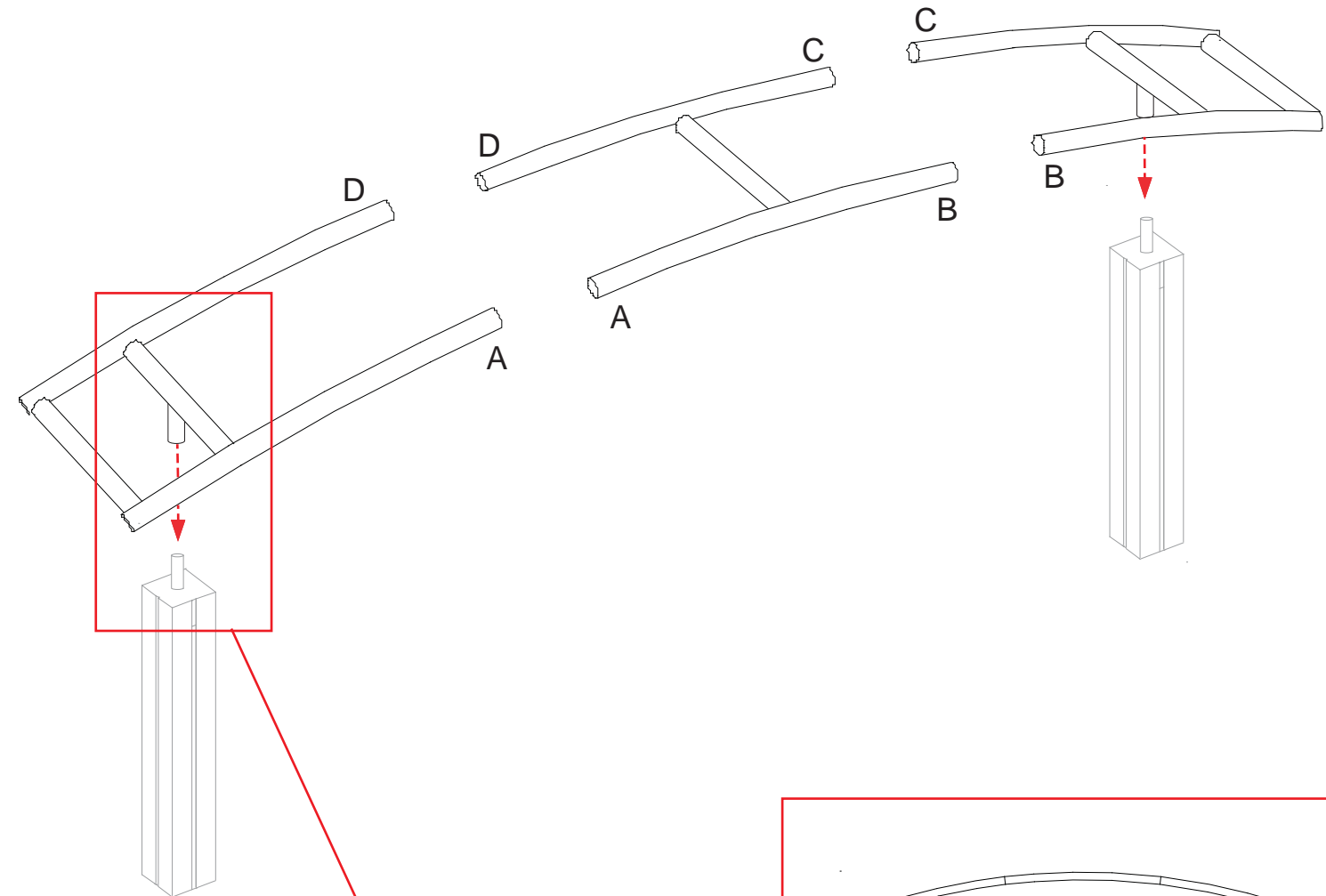

Connections are made by holding the button down and sliding the red tube into opposing tube until the connection is made. To disassemble push button and pull or twist extrusions apart.

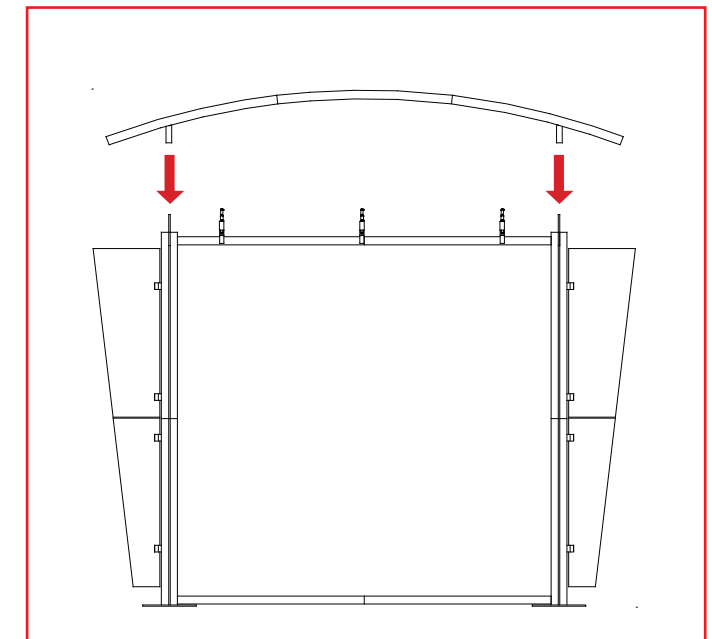
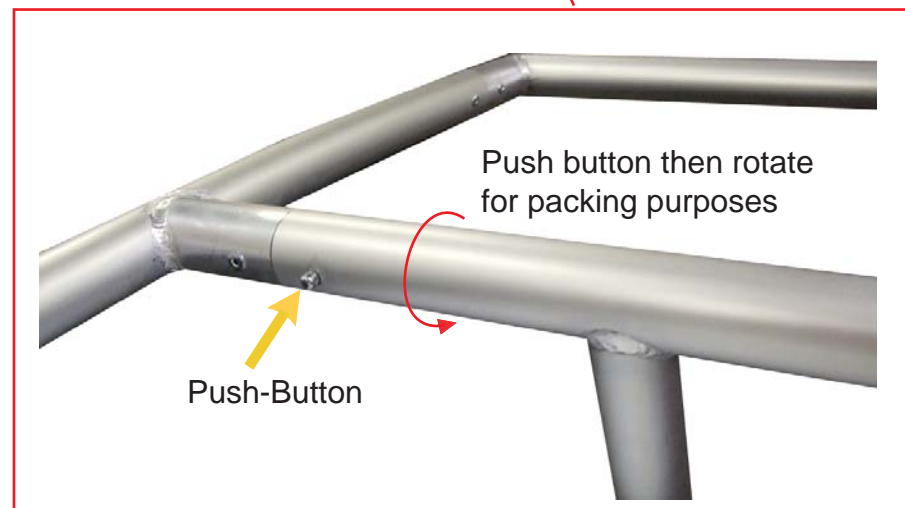
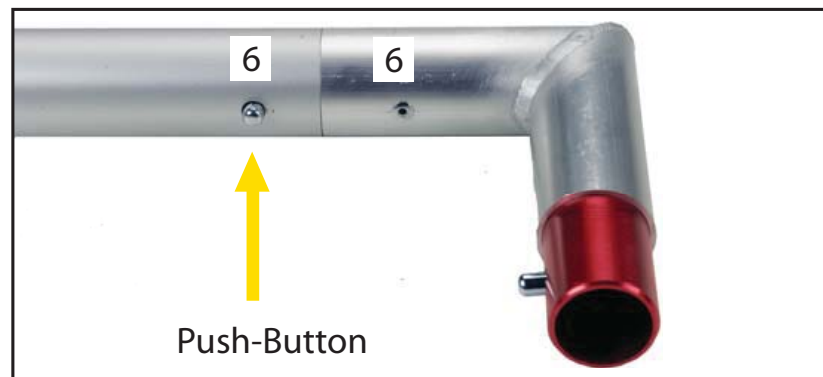

WHEN DISASSEMBLING ALUMINUM EXTRUSION, TIGHTEN ALL SETSCREWS AND LOCKS TO PREVENT LOSS DURING SHIPPING

Item	Qty.	Description
6	1	38" Vertical Extrusion
6a	1	Vertical Extrusion/ Door Stopper
7	2	38" Vertical Extrusion
8	1	38" Vertical Extrusion
9	8	15" Horizontal Extrusion

Steps:

- 1) Attach door stopper extrusion [6a] to vertical extrusion [6].
Note: Extrusions [6 and 6a] should remain assembled when shipping.
- 2) Connect horizontal extrusions [9] between vertical extrusions [6/6a, 7 and 8] as shown.
- 3) Place hooks on extrusions [9], see hook placement detail, then set floor on hooks.
- 4) Place inserts and attach door as indicated.
- 5) Connect horizontal extrusions [9] between vertical extrusions [6/6a, 7 and 8] and atop inserts.
- 6) Velcro shelf supports to inside of assembled pedestal, then set internal shelf atop supports.
- 7) Place coner top atop assembled pedestal as shown.
- 8) Repeat steps for additional pedestal.

866.652.2100

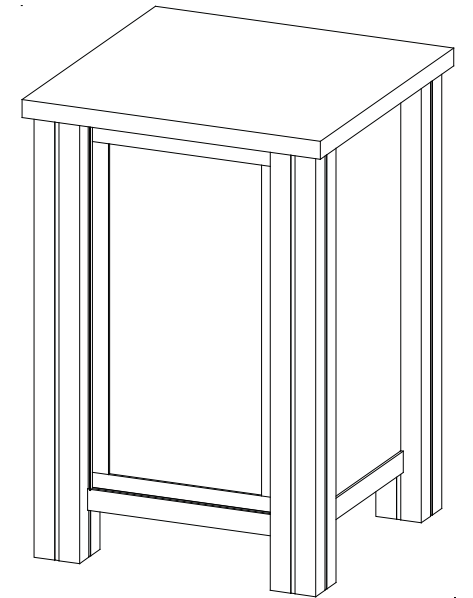

QTY. 2

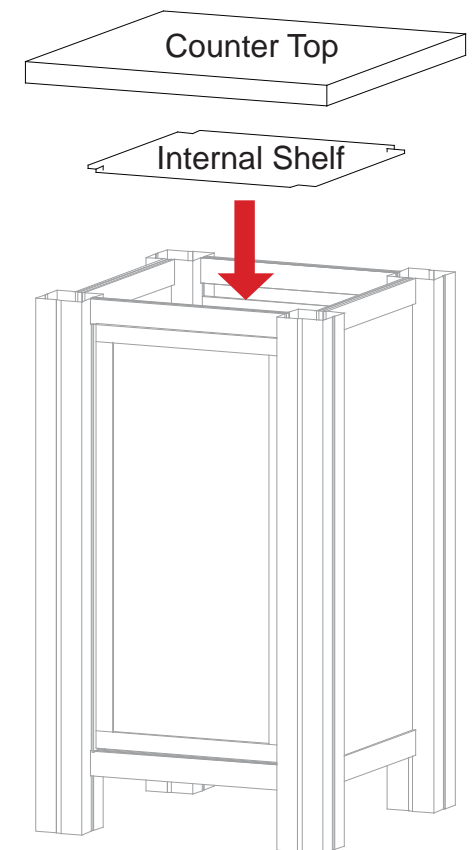
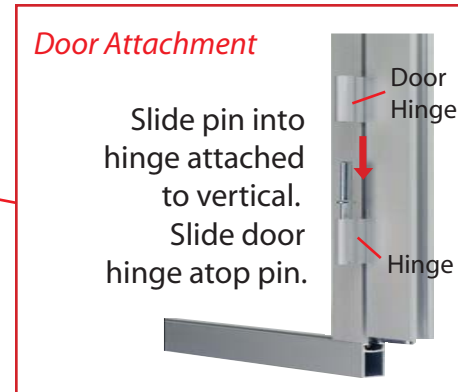
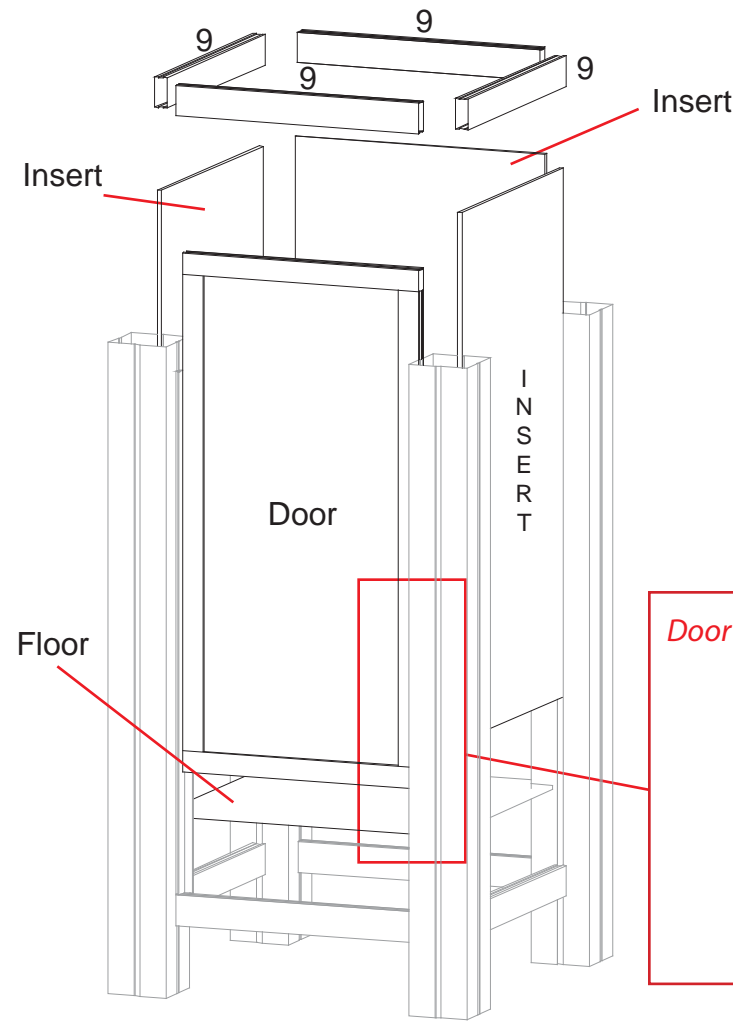
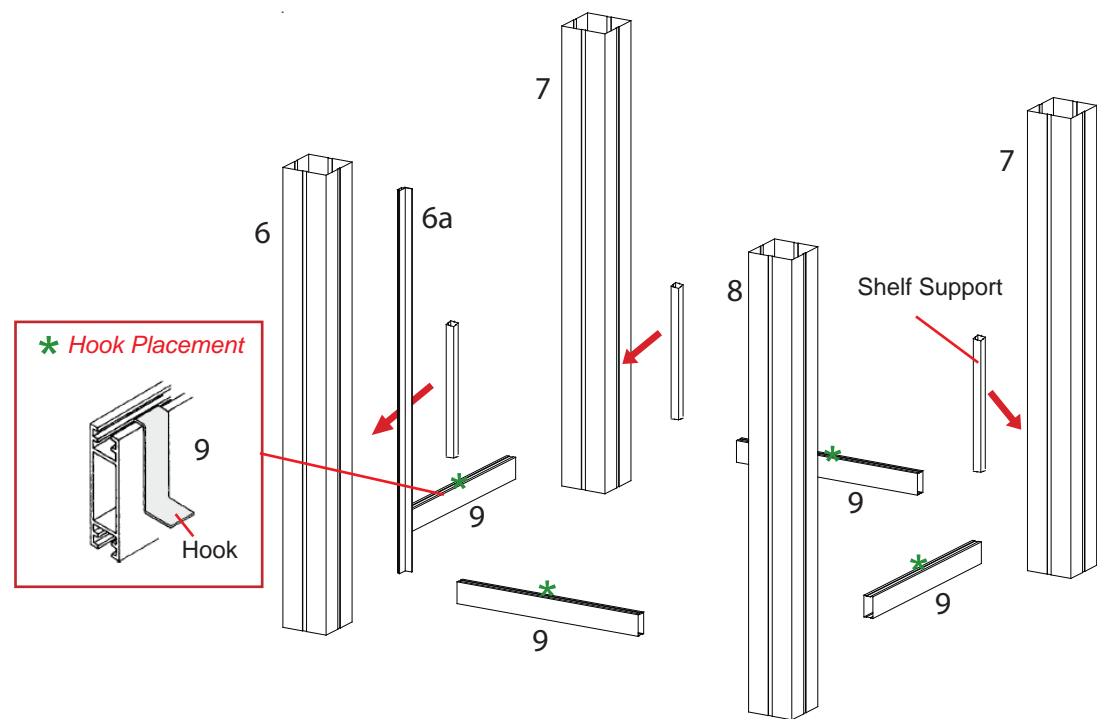

WHEN DISASSEMBLING ALUMINUM EXTRUSION, TIGHTEN ALL SETSCREWS AND LOCKS TO PREVENT LOSS DURING SHIPPING

Item	Qty.	Description
10	4	38" h Vertical Extrusion
11	2	34" w Horizontal Extrusion
12	2	16" w Horizontal Extrusion
13	1	34.418" h Vertical Extrusion w/ Door Hinges
14	1	34.418" h Vertical Extrusion w/ Door Stop
15	3	34" w Horizontal Extrusion
16	2	15.5" w Horizontal Extrusion

Steps:

- 1) Attach horizontal extrusions [11 and 12] between vertical extrusions [10].
- 2) Attach vertical extrusions [13 and 14] to horizontal extrusion [11], leave loose.
- 3) Place inserts and door between vertical extrusions, attaching horizontal extrusion [15] between inserts as shown.
- 4) Attach horizontal extrusions [15 and 16] between vertical extrusions [10] and atop inserts and door.
- 5) Velcro shelf supports to inside of assembled base.
- 6) Place internal shelf atop supports.
- 7) Set counter top on assembled pedestal as shown.

866.652.2100

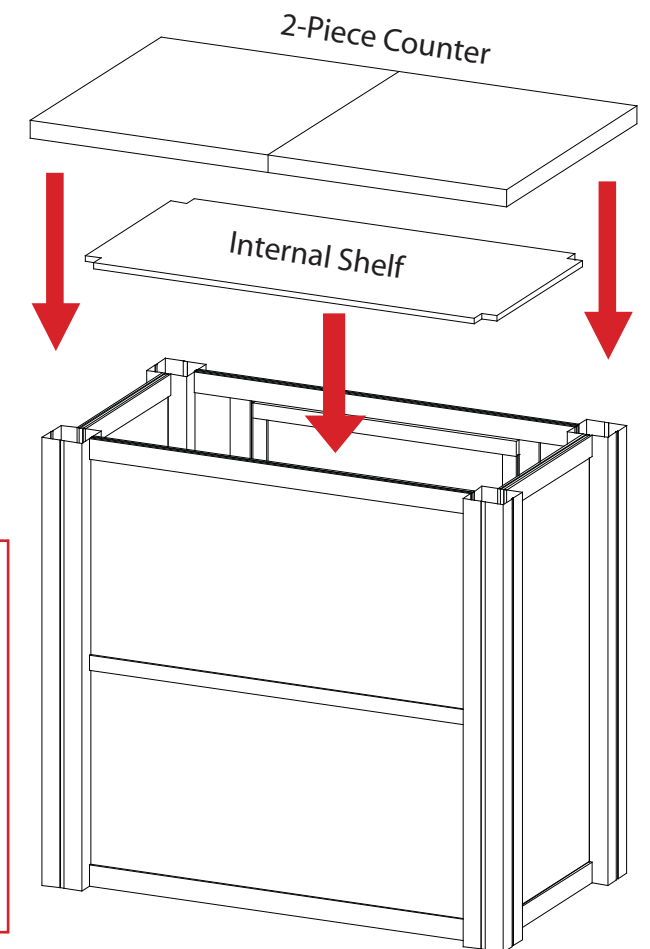
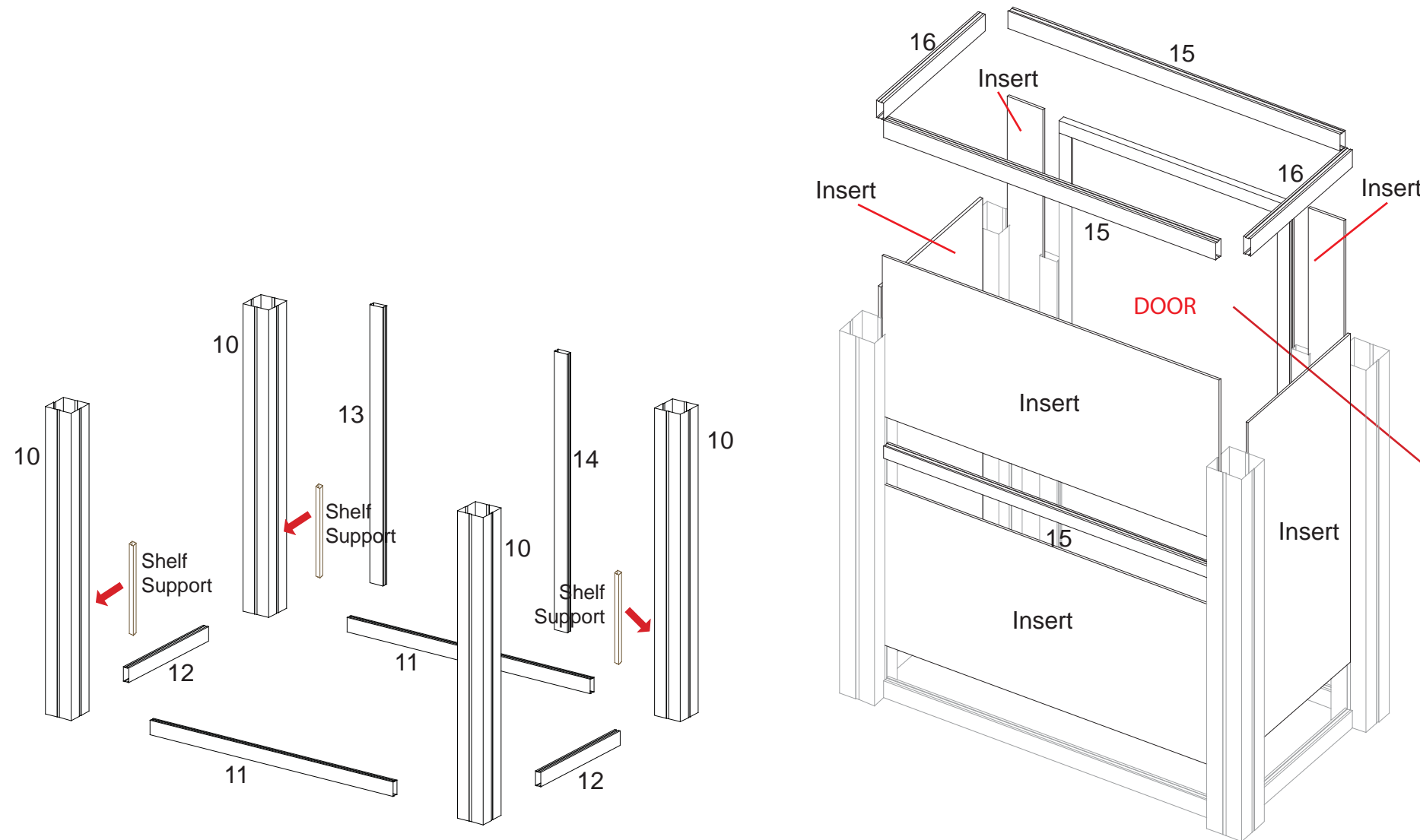
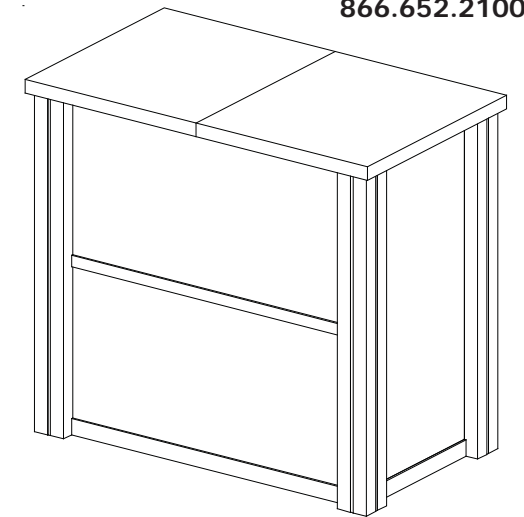



Door Attachment



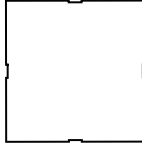

Slide pin into hinge attached to vertical.
Slide door hinge atop pin.

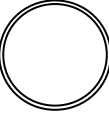
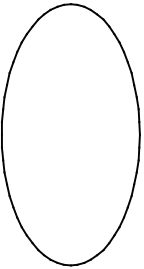
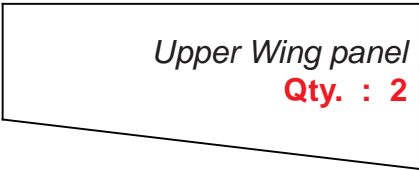
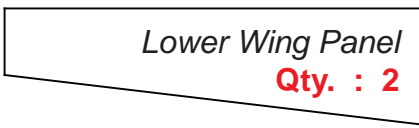
WHEN DISASSEMBLING ALUMINUM EXTRUSION, TIGHTEN ALL SETSCREWS AND LOCKS TO PREVENT LOSS DURING SHIPPING



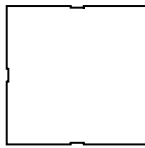

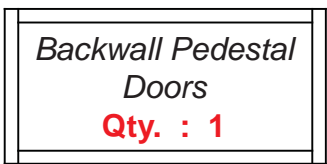
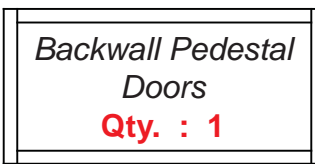
Backwall Components

-  **42" Square Extrusion**
Qty. : 4
Located in Case : 1
-  **42" Extrusion**
Qty. : 4
Located in Case : 2
-  **Extrusion for Graphic Attachment**
Qty. : 4
Located in Case : 2
-  **Standard Curved Canopy Section**
Qty. : 2 Sections
Located in Case : 2
Qty. : 1 Sections
Located in Case : 1
-  **Oval Base Plate**
Qty. : 2
Located in Case : 4
-  **Upper Wing panel**
Qty. : 2
Located in Case : 1
-  **Lower Wing Panel**
Qty. : 2
Located in Case : 1

Backwall Pedestal Components

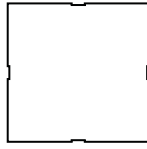
-  **38" Square Extrusion**
Qty. : 4
Located in Case : 4
Qty. : 4
Located in Case : 5
-  **15" Extrusion**
Qty. : 10
Located in Case : 5
Qty. : 6
Located in Case : 3
-  **Backwall Pedestal Doors**
Qty. : 1
Located in Case : 4
-  **Backwall Pedestal Doors**
Qty. : 1
Located in Case : 5
-  **Backwall Pedestal Inserts**
Qty. : 6
Located in Case : 2

Pedestal Components

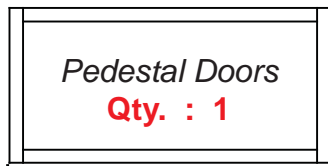
-  **38" Square Extrusion**
Qty. : 4
Located in Case : 3
-  **15.5" Extrusion**
Qty. : 4
Located in Case : 3
-  **34" Extrusion**
Qty. : 5
Located in Case : 4
-  **34.418" Extrusion**
Qty. : 2
Located in Case : 5
-  **Pedestal Doors**
Qty. : 1
Located in Case : 3

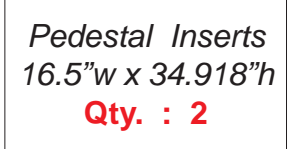
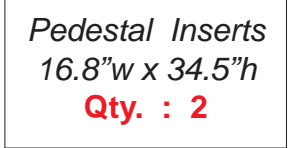
-  **Pedestal Inserts**
Qty. : 2
Located in Case : 3
-  **Pedestal Inserts**
16.5" w x 34.918" h
Qty. : 2
Located in Case : 3
-  **Pedestal Inserts**
16.8" w x 34.5" h
Qty. : 2
Located in Case : 3

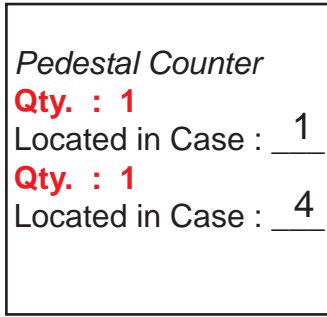
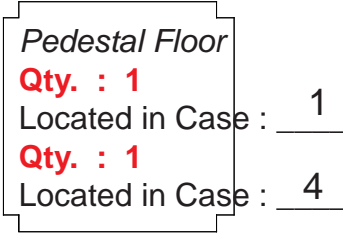
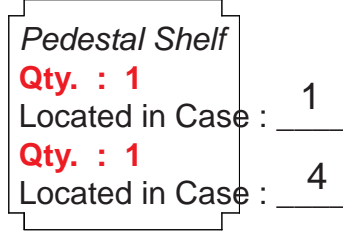
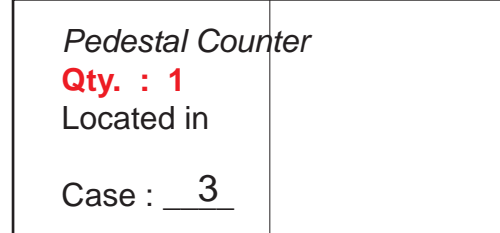
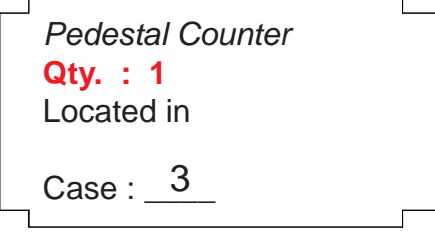
-  **Pedestal Counter**
Qty. : 1
Located in Case : 1
Qty. : 1
Located in Case : 4
-  **Pedestal Floor**
Qty. : 1
Located in Case : 1
Qty. : 1
Located in Case : 4
-  **Pedestal Shelf**
Qty. : 1
Located in Case : 1
Qty. : 1
Located in Case : 4
-  **Pedestal Counter**
Qty. : 1
Located in Case : 3
-  **Pedestal Counter**
Qty. : 1
Located in Case : 3

- Additional Accessories:**
- Setup Hardware in case 1
 - Lights in case 2
 - Graphic in case 2
 - _____ in case _____
 - _____ in case _____

WHEN DISASSEMBLING ALUMINUM EXTRUSION, TIGHTEN ALL SETSCREWS AND LOCKS TO PREVENT LOSS DURING SHIPPING