



Item	Quantity	Description
52	3	96" h Vertical Extrusion
53	4	38" h Vertical Extrusion
54	2	27.5" w Horizontal Extrusion
55	2	27.5" w Horizontal Extrusion
56	2	27.5" w Horizontal Extrusion

Item	Quantity	Description
57	2	27.5" w Horizontal Extrusion
58	2	27.5" w Horizontal Extrusion
59	2	27.5" w Horizontal Extrusion
60	8	Curved Horizontal Extrusion
61	2	19.8356" h Vertical Extrusion w/ Door Stop
62	2	19.8356" h Vertical Extrusion w/ Hinges

Steps:

- 1) Attach T extrusions [53] to vertical extrusions [52] as shown.
- 2) Attach horizontal extrusions [54 thru 59] between vertical extrusions in numerical order, inserting sintra panels and graphics where indicated.
Note: See plan view for oval extrusion orientation.
- 3) Connect lower curved extrusions [60] to T extrusions [53].
- 4) Attach extrusions [61 and 62] atop curved horizontals [60], leave loose.
- 5) Attach doors and place inserts as indicated.
- 6) Attach curved extrusions [60] to T extrusions [53], placing insert where indicated.
- 7) Place counters atop base as shown.
- 8) Apply fabric graphics to back of extrusions [54] and [58].

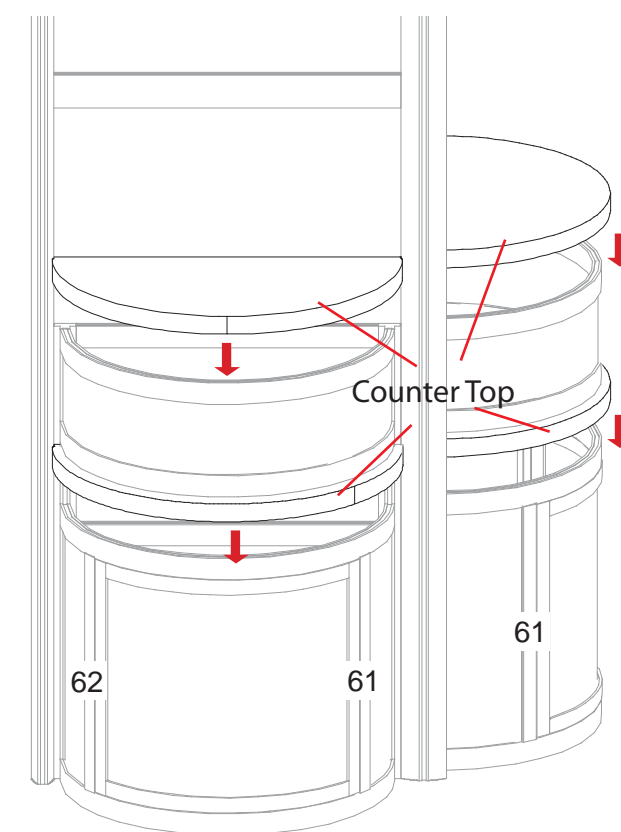
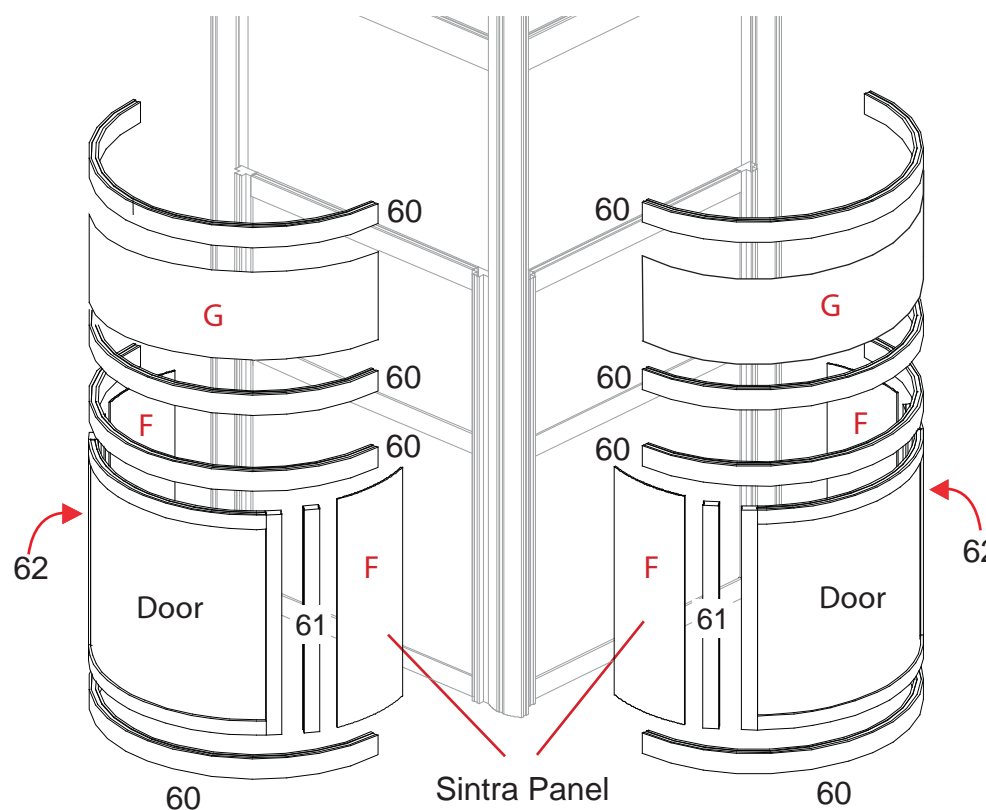
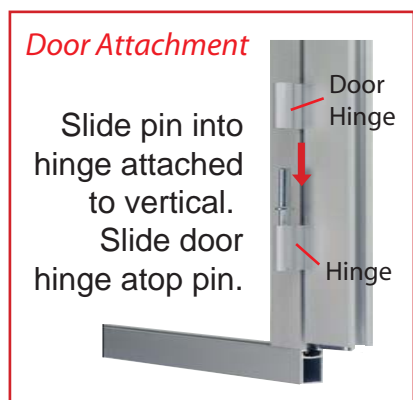
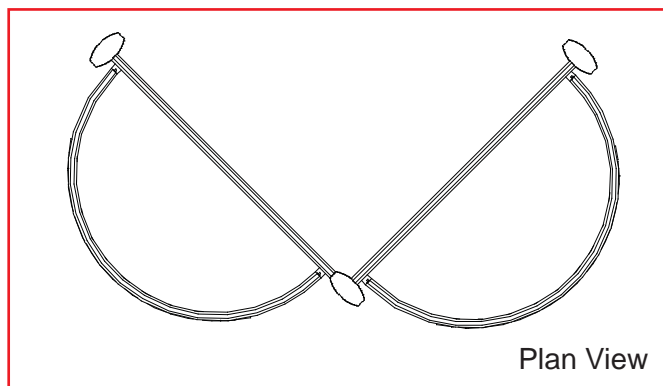
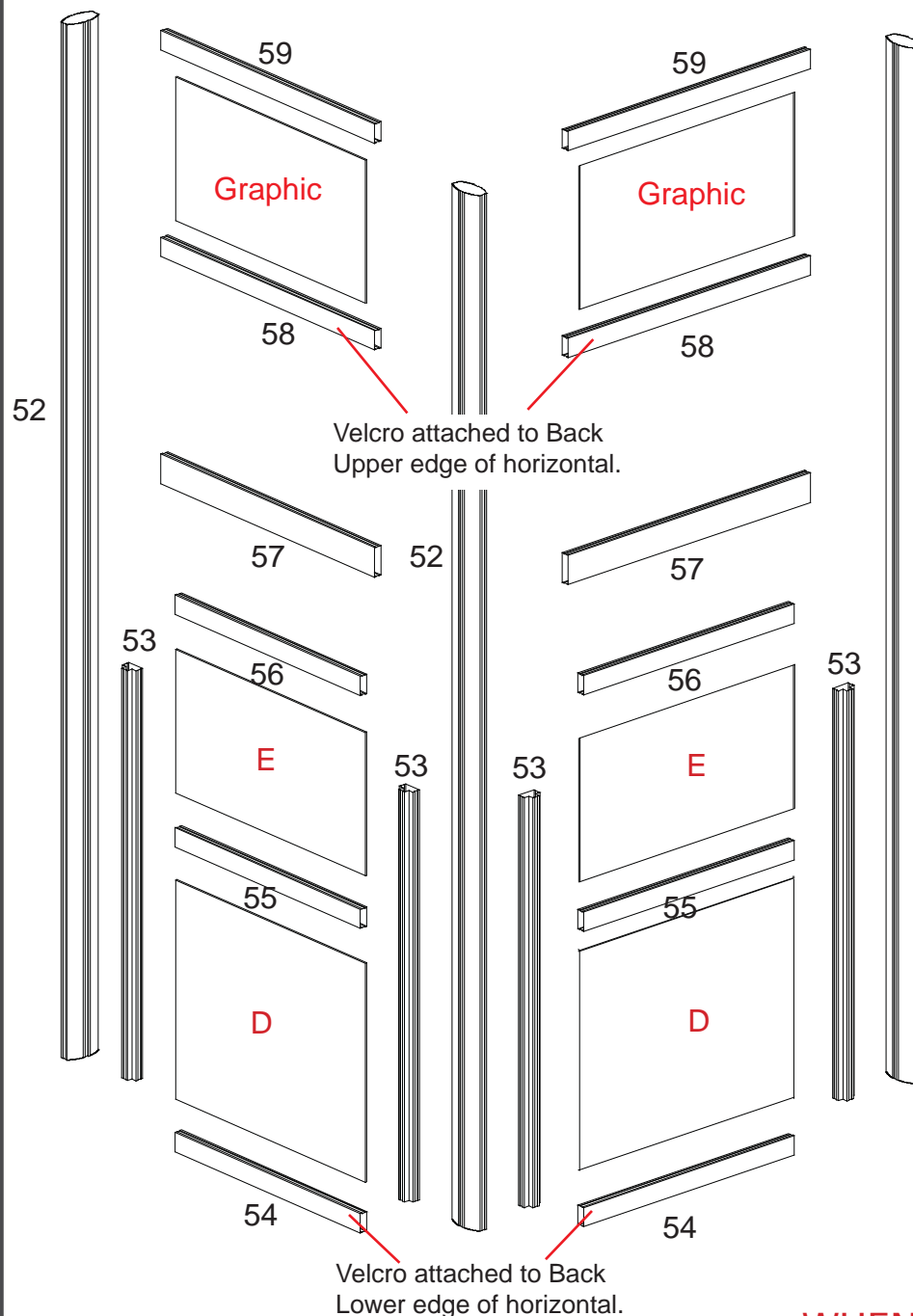

WHEN DISASSEMBLING ALUMINUM EXTRUSION, TIGHTEN ALL SETSCREWS AND LOCKS TO PREVENT LOSS DURING SHIPPING

visionary™ IDESIGNS

Using Your Setup Instructions

The Visionary Designs Setup Instructions are created specifically for your configuration. They are laid out sequentially, including an exploded view of the entire display, and then a logical series of detailed steps to assemble the main structure and components. We encourage you to study the instructions **before** attempting to assemble your exhibit.

Each page reminds you to tighten the setscrews after disassembling your exhibit to prevent loss of the locks and setscrews (see below in RED). This is **VERY IMPORTANT**.

Cleaning and Packing Your Display

- 1) Use care when cleaning aluminum extrusion or acrylic inserts. Use only non-abrasive cleaners.
- 2) When cleaning laminate inserts or countertops, use mild cleansers and a soft material such as cotton.
- 3) Keep all display components away from extreme heat and long exposure to sunlight to avoid warping and fading.
- 4) Retain all packing material. It will make re-packing much easier and will reduce the likelihood of shipping damage.



The Tool

Most Visionary Designs exhibits can be assembled with the supplied Hex Key Tool. Occasionally, a flat head screwdriver may be required.



Typical Connection

Most horizontal extrusion connections have a patented expandable lock. This lock inserts into the groove of an opposing extrusion. Tightening the lock with the Hex Key Tool expands the lock and creates a strong positive connection.



Typical Connection (cont'd)

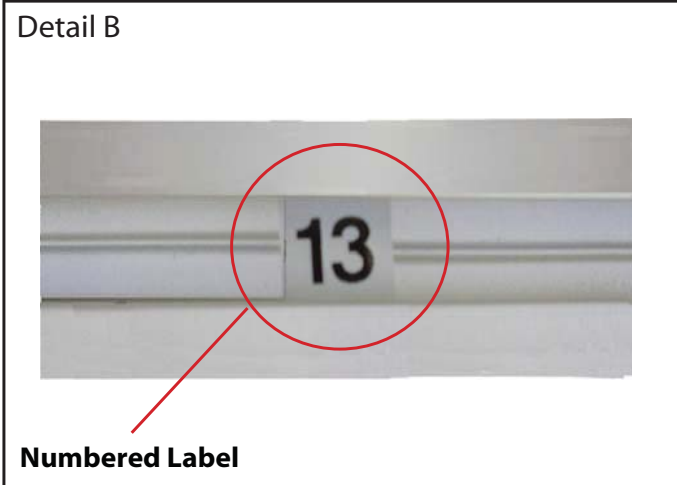

Numbered Label

Each extrusion contains a numbered label which corresponds with setup instructions. The label is located within a groove of the extrusion (when possible). With Visionary Designs the labels contain Black numbers unless otherwise specified.



Horizontal Inline Connection (remove only one setscrew)

Remove only (1) setscrew when disassembling. Replace setscrew in extrusion after assembling it. Before packing, replace setscrew in extrusion to avoid losing it.

NOTE :

PDF copies of your Setup Instructions are available @ www.classicexhibits.com
Use the Search Tool located on the lower left-hand corner of the Classic Home page.

Enter your 5-7 digit Order #. Search for Setup Instructions

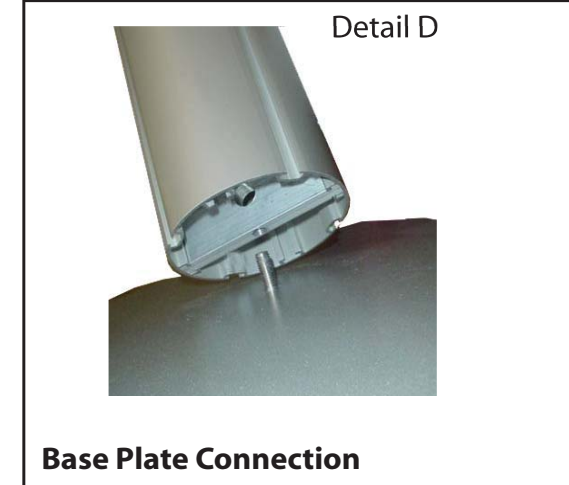

Base Plate Connection

Attach base plate to round or square vertical extrusion using the bolt provided. Be careful not to strip the threads.

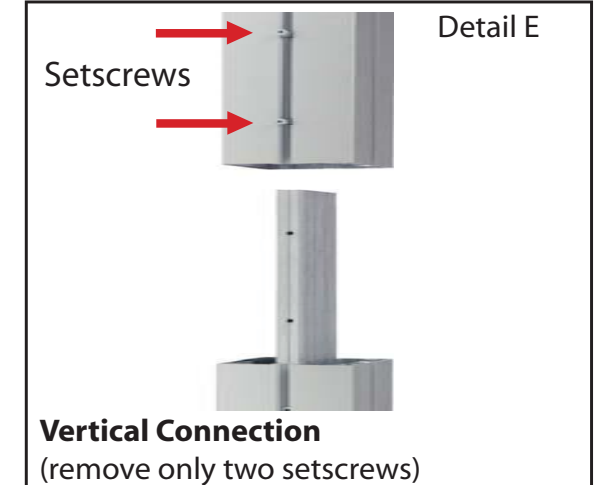

Vertical Connection
(remove only two setscrews)

When vertical extrusions are packed in portable cases rather than crates or tubs, they must be broken down into smaller sections which then require assembly.

Remove only (2) setscrews when disassembling. Replace setscrews in extrusion after assembling it. Before packing, replace setscrews in extrusion to avoid losing them.

WHEN DISASSEMBLING ALUMINUM EXTRUSION, TIGHTEN ALL SETSCREWS AND LOCKS TO PREVENT LOSS DURING SHIPPING