

# euro It | *HYBRIDS*

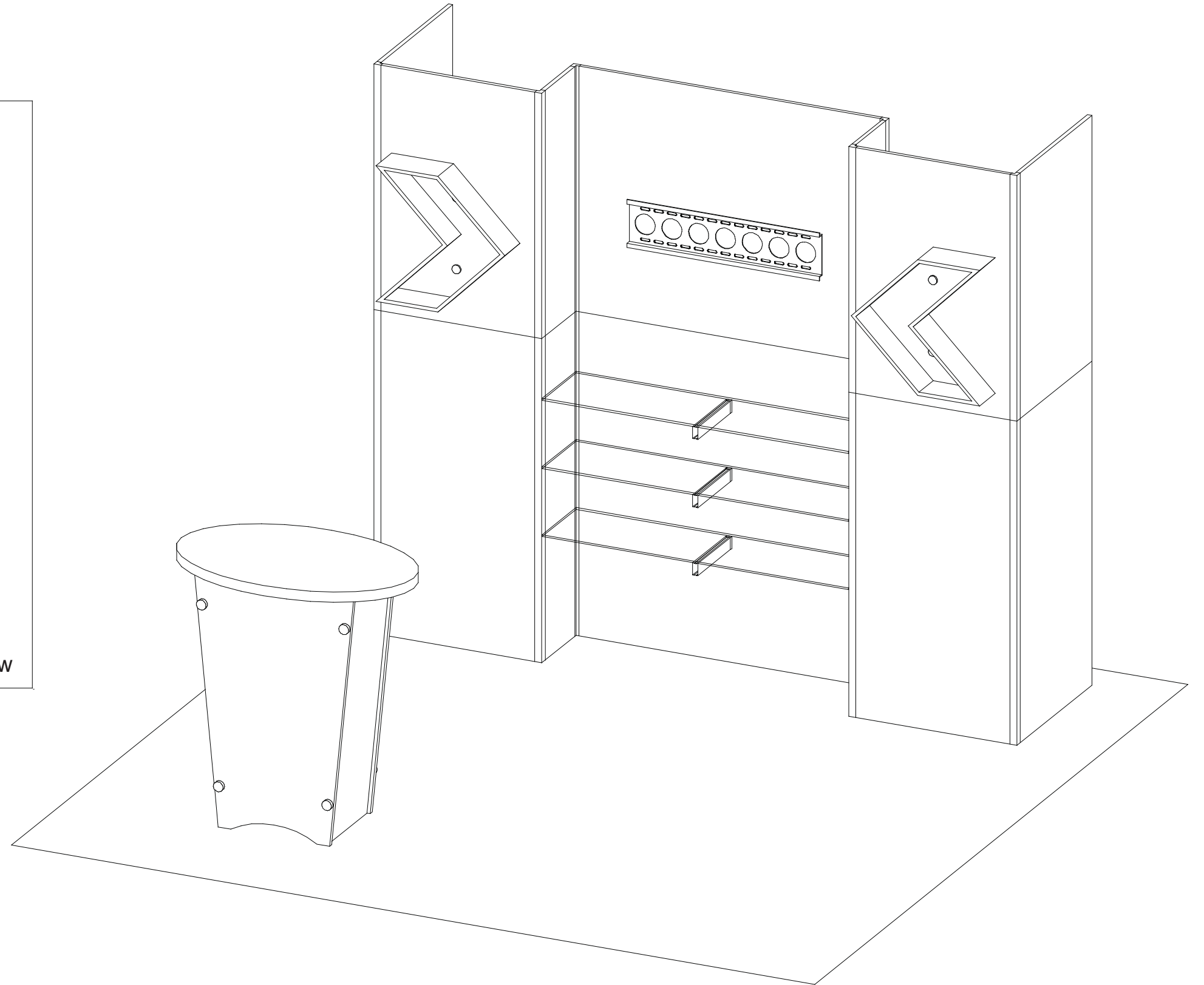
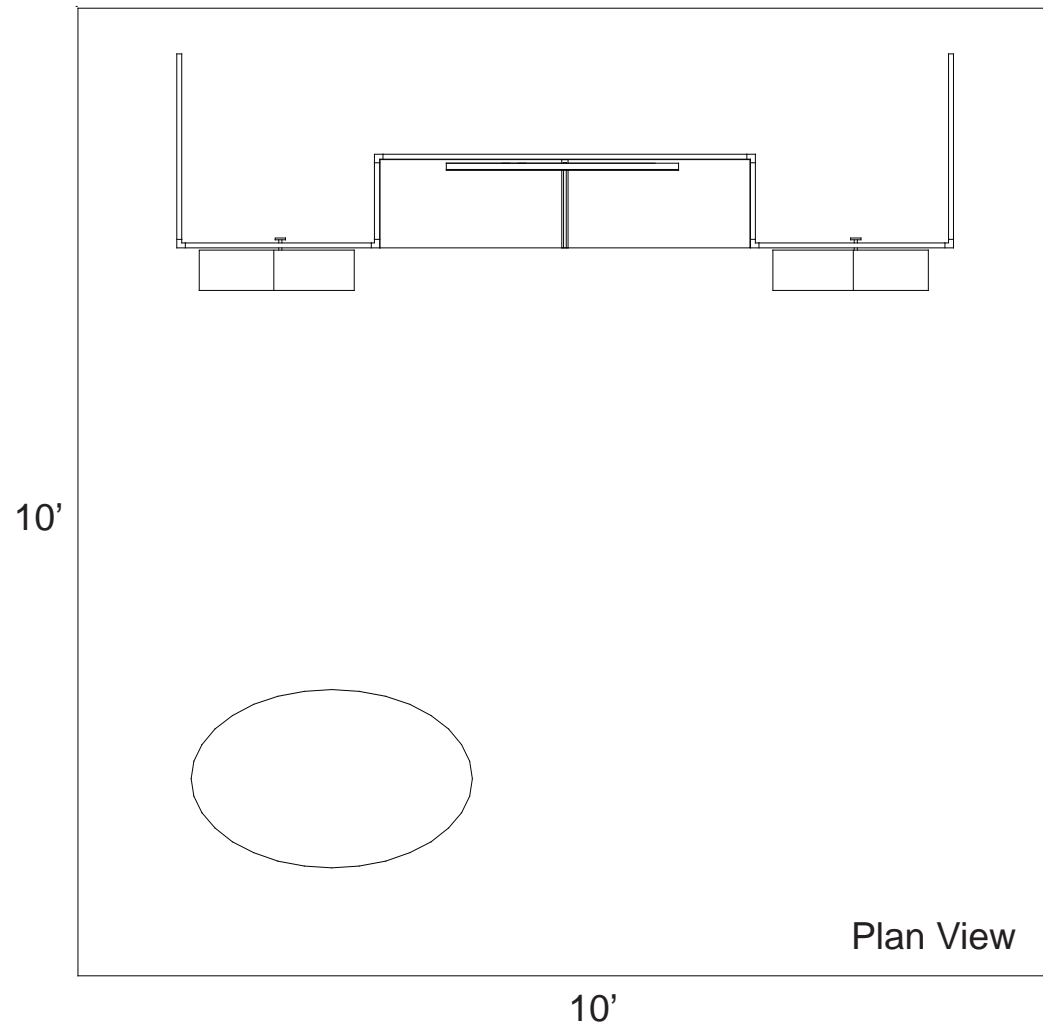

# euro lt | HYBRIDS

## Euro LT Hybrids General Setup Instructions

### Using Your Setup Instructions

The Euro LT Hybrids Setup Instructions are created specifically for your configuration. They are laid out sequentially in levels, including exploded views, and a logical series of detailed steps to assemble the main structure and components. We encourage you to study the instructions **before** attempting to assemble your exhibit.

### Cleaning and Packing Your Display

- 1) When cleaning laminate countertops or panels use mild cleansers and a soft material such as cotton.
- 2) Keep all display components away from extreme heat and long exposure to sunlight to avoid warping and fading.
- 3) Retain all packing material. It will make re-packing much easier and will reduce the likelihood of shipping damage.

Level 1 = Blue  
 Level 2 = Red  
 Level 3 = Green  
 Level 4 = Black

#### Color Code

The top clip is color coded to distinguish the level. The color coded clip also contains the numbered label

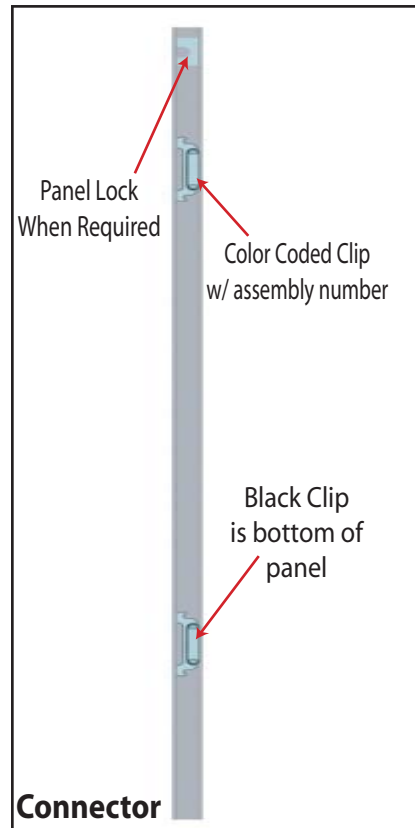

Each component has 2 clips, the lower clip is ALWAYS black..

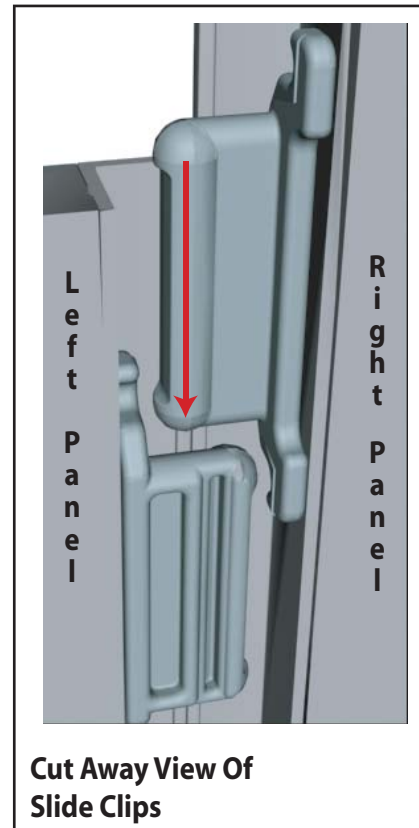

Components connect together by aligning them and sliding downward connecting clips together.

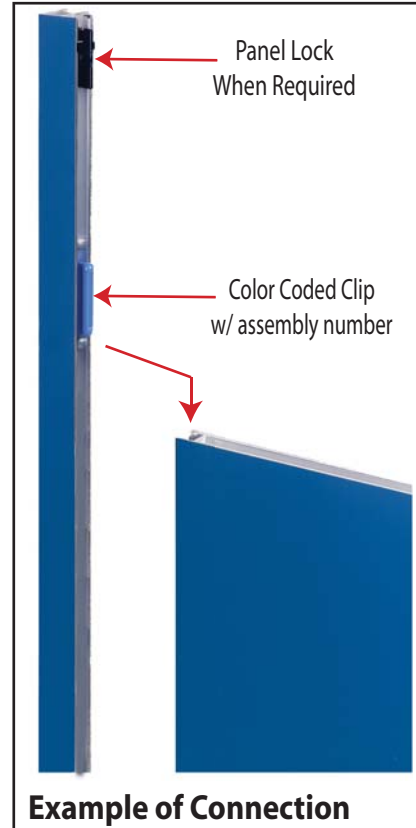

Configurations are assembled from left to right, usually starting with #1 and following the numbered sequence.



The first level of components contains panel locks that are located at the top of the panel for extra stability and a seamless connection. When disassembling panels, twist top connection slightly and lift right panel upward.

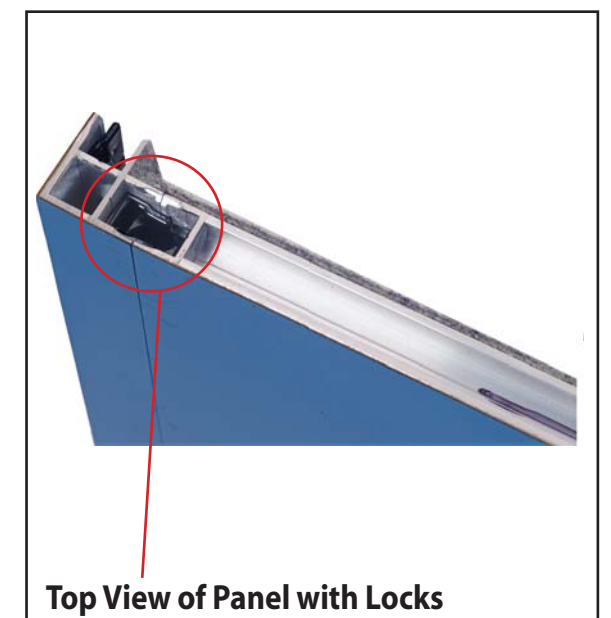

866.652.2100

Item Number	Description
1	23"w x 47.5"h Flat Panel
2	47.5"h 90° Connector
3	23"w x 47.5"h Flat Panel
4	47.5"h 90° Connector
5	9.5"w x 47.5"h Flat Panel
6	47.5"h 90° Connector
7	45"w x 47.5"h Flat Panel w/ Connectors Attached
8	47.5"h 90° Connector
9	9.5"w x 47.5"h Flat Panel
10	47.5"h 90° Connector
11	23"w x 47.5"h Flat Panel
12	47.5"h 90° Connector
13	23"w x 47.5"h Flat Panel

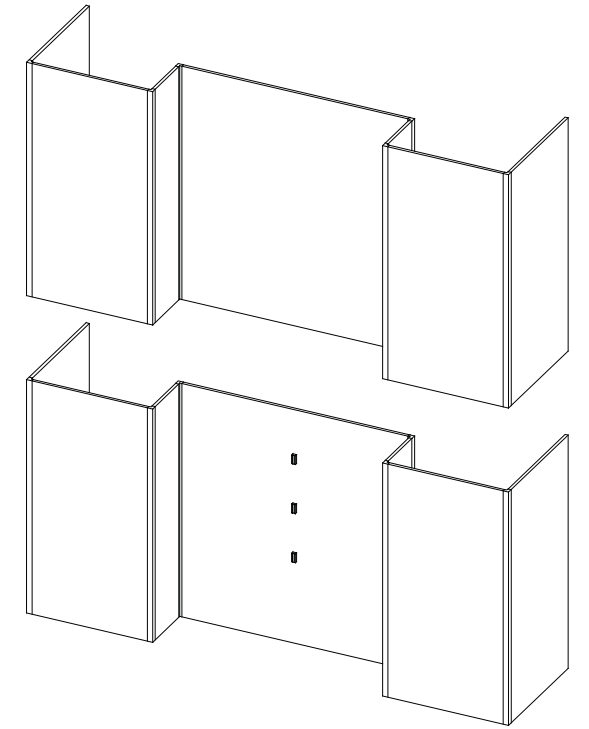

Steps:  
Connect panels together in numerical order as shown in illustrations.

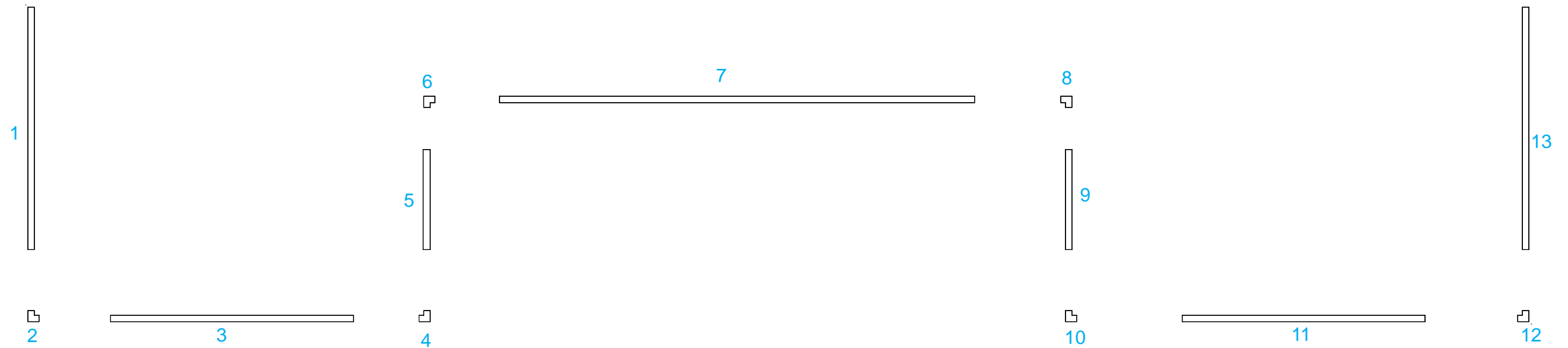

866.652.2100

Item Number	Description
1	23" w x 36" h Flat Panel
2	36" h 90° Connector
3	23" w x 36" h Flat Panel
4	36" h 90° Connector
5	9.5" w x 36" h Flat Panel
6	36" h 90° Connector
7	45" w x 36" h Flat Panel w/ Wood Core
8	36" h 90° Connector
9	9.5" w x 36" h Flat Panel
10	36" h 90° Connector
11	23" w x 36" h Flat Panel
12	36" h 90° Connector
13	23" w x 36" h Flat Panel

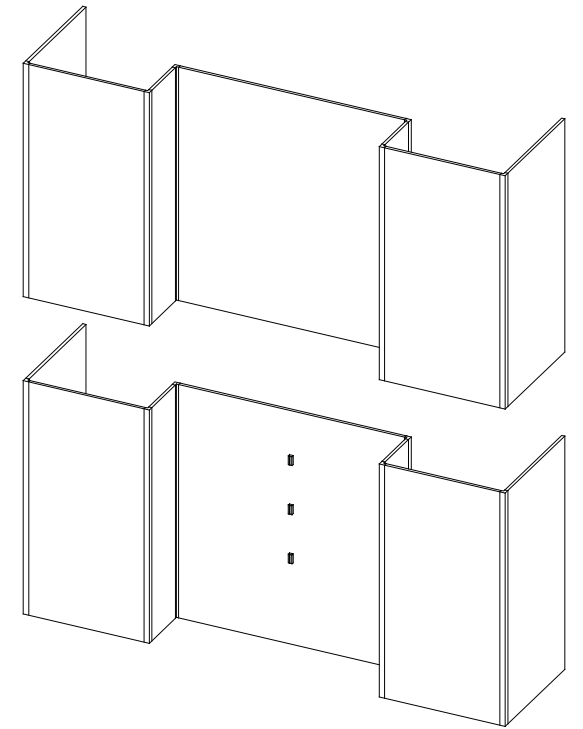

Steps:  
Connect panels together in numerical order as shown in illustrations.

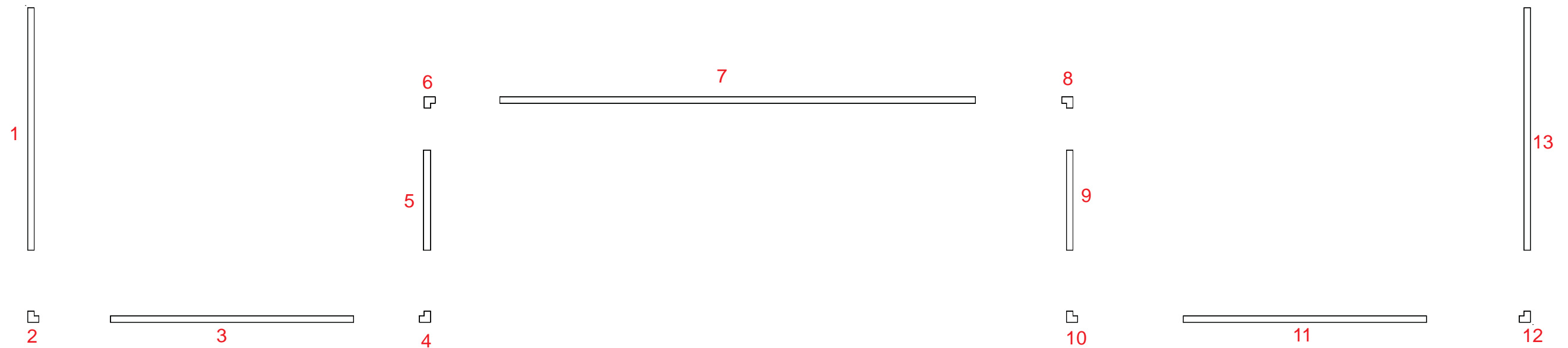

Item	Qty.	Description
1	3	10.47" w Horizontal Extrusion

Steps:

- 1) Attach pins to backwall where indicated.
- 2) Attach extrusions [1] to connectors.
- 3) Place shelves atop pins and extrusions.
- 4) Attach decorative pieces to backwall as shown.
- 5) Attach monitor mount to backwall, see monitor mount attachment detail.
- 6) Hook header onto top of truss.

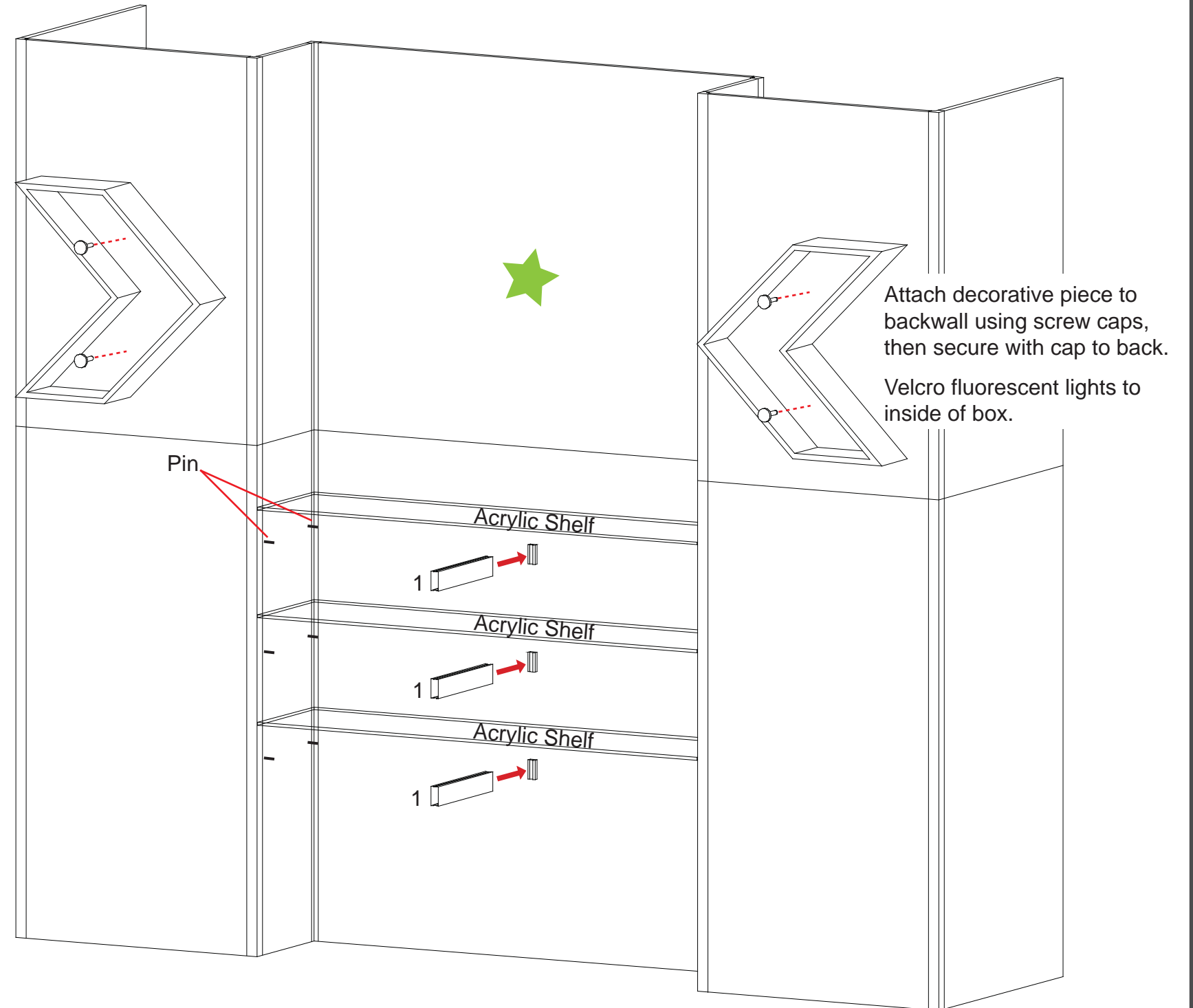
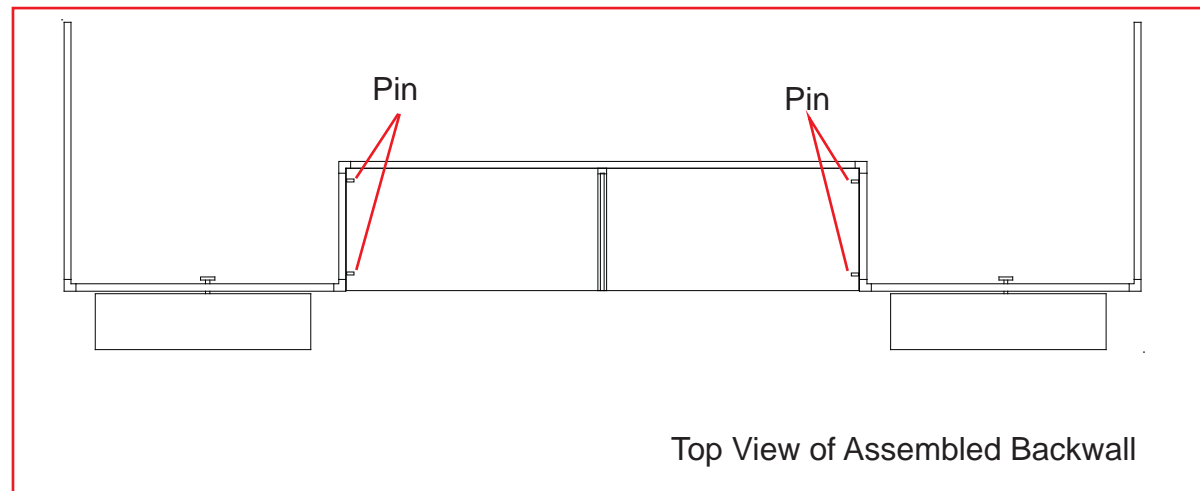
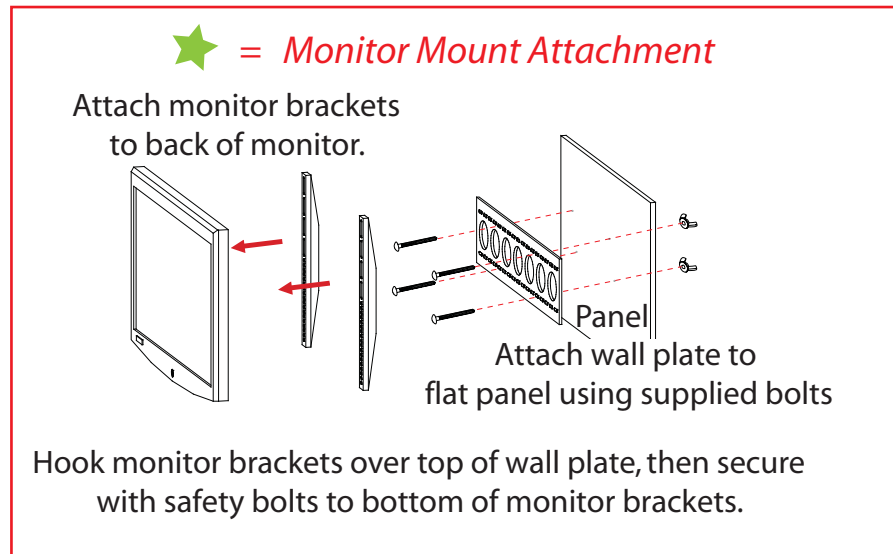

866.652.2100

Setup Instructions:

- A) Use standoff screws to secure the front panel with door and back panel of the pedestal to the side panels.
- B) After assembling front, back, and side panels, slide floor into the bottom of the pedestal. The floor will sit on pins on the inside of the side panels.
- C) After floor is in place, use velcro attachments to install shelf.

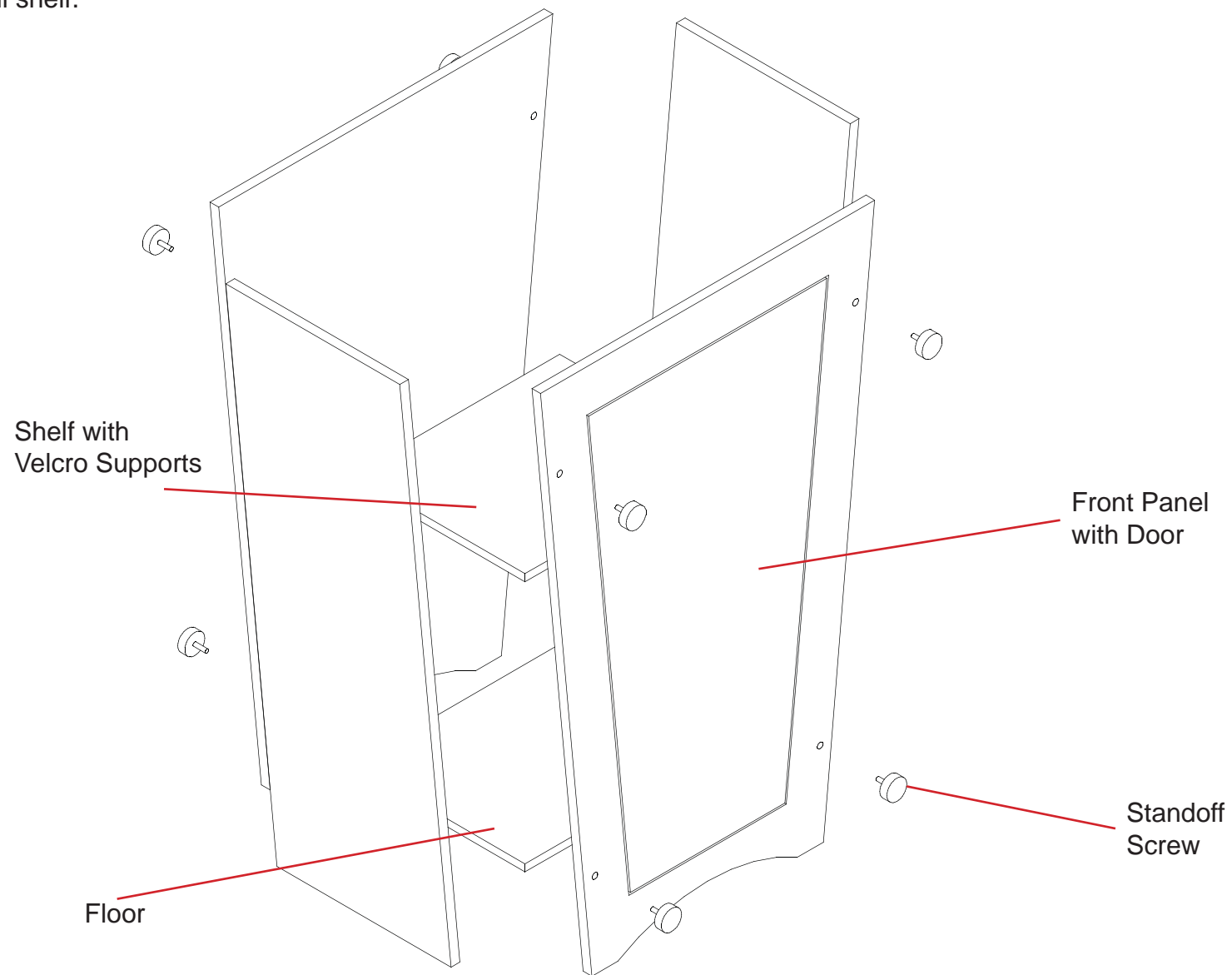
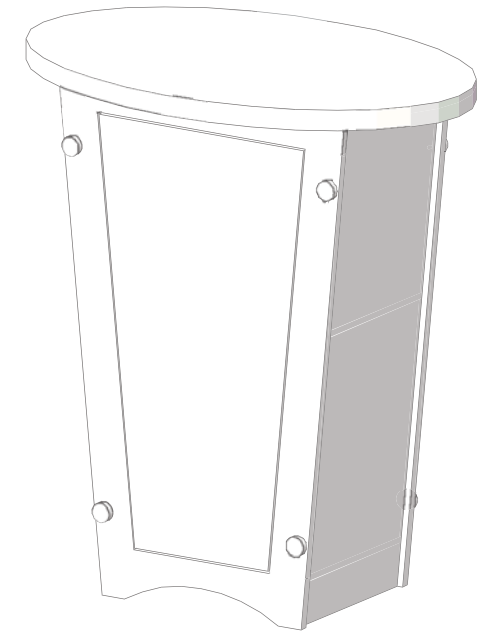

Attach the oval counter top to the pedestal base.

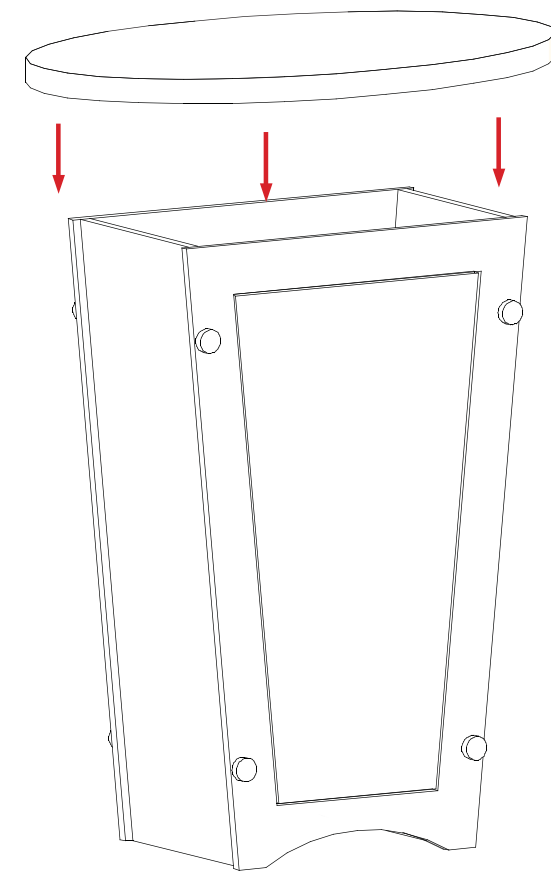

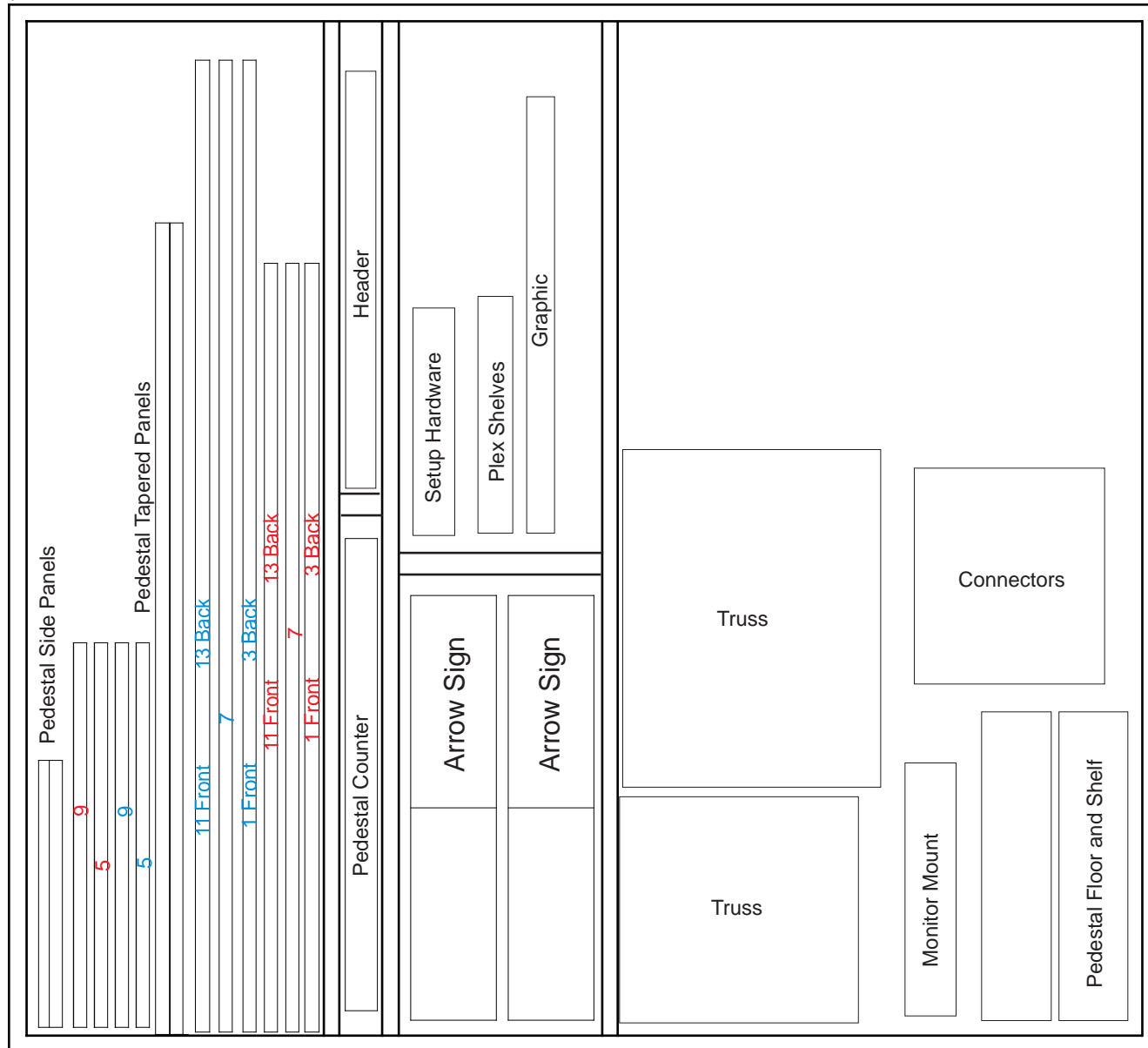

Front View of Crate