

# euro It | HYBRIDS

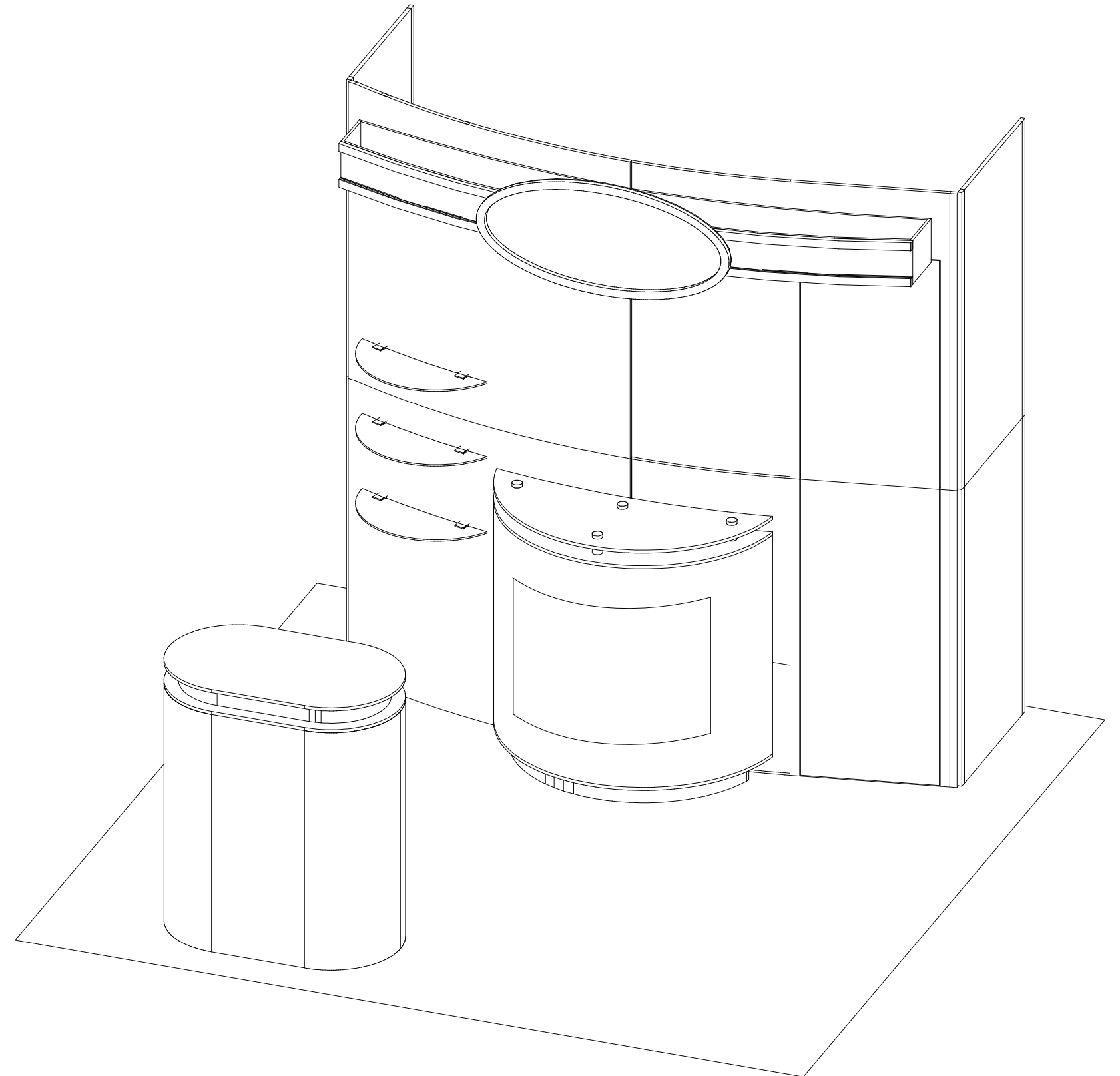
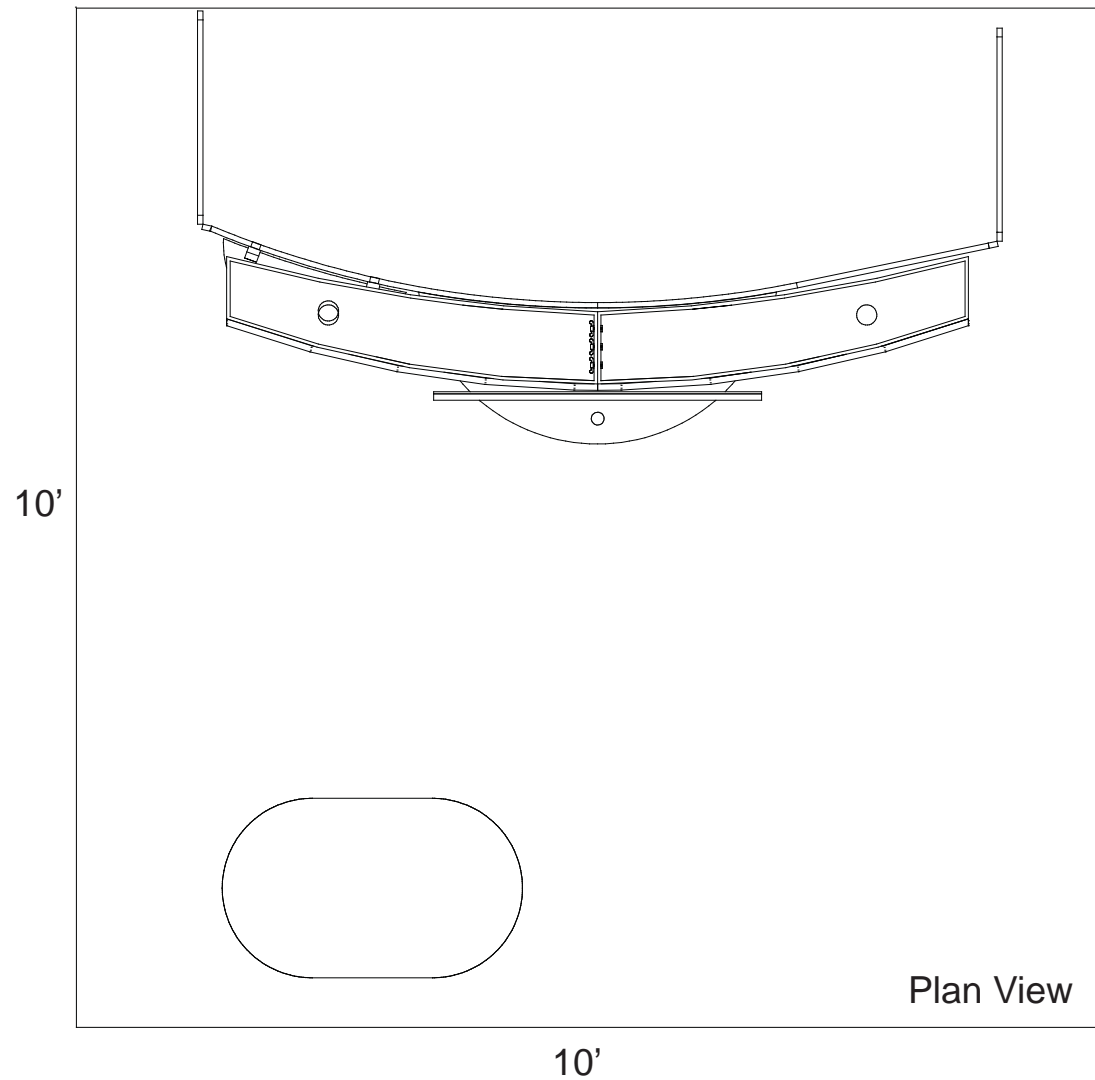

# euro lt | HYBRIDS

## Euro LT Hybrids General Setup Instructions

### Using Your Setup Instructions

The Euro LT Hybrids Setup Instructions are created specifically for your configuration. They are laid out sequentially in levels, including exploded views, and a logical series of detailed steps to assemble the main structure and components. We encourage you to study the instructions **before** attempting to assemble your exhibit.

### Cleaning and Packing Your Display

- 1) When cleaning laminate countertops or panels use mild cleansers and a soft material such as cotton.
- 2) Keep all display components away from extreme heat and long exposure to sunlight to avoid warping and fading.
- 3) Retain all packing material. It will make re-packing much easier and will reduce the likelihood of shipping damage.

Level 1 = Blue  
 Level 2 = Red  
 Level 3 = Green  
 Level 4 = Black

#### Color Code

The top clip is color coded to distinguish the level. The color coded clip also contains the numbered label

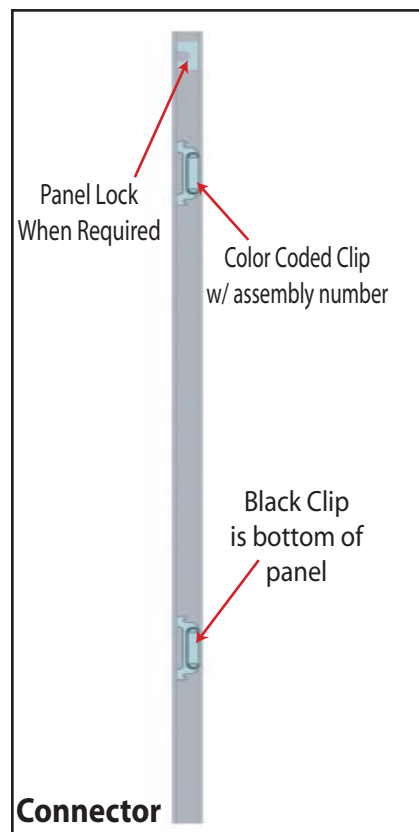

Each component has 2 clips, the lower clip is ALWAYS black..

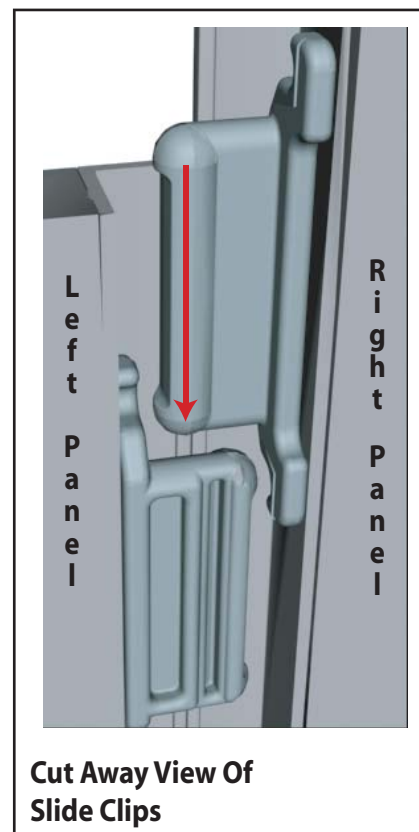

Components connect together by aligning them and sliding downward connecting clips together.

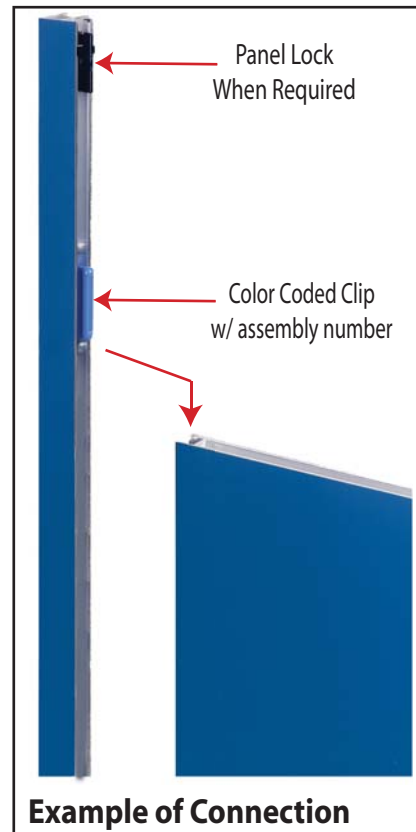

Configurations are assembled from left to right, usually starting with #1 and following the numbered sequence.

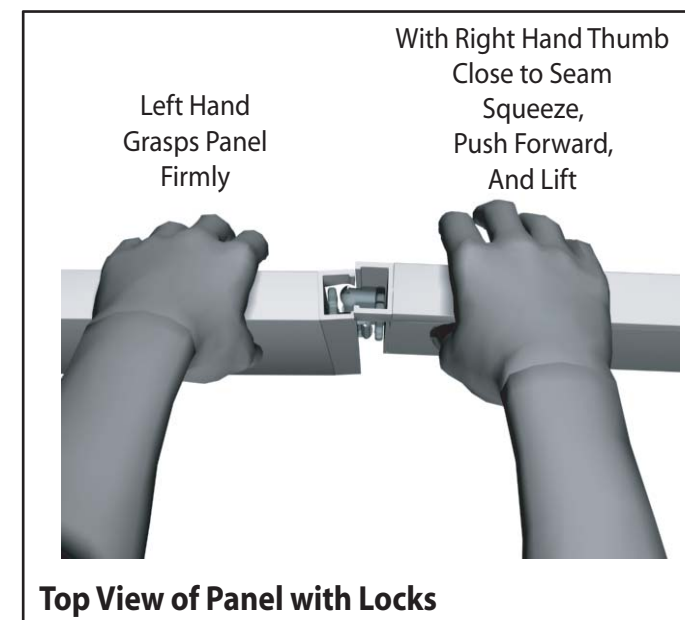

The first level of components contains panel locks that are located at the top of the panel for extra stability and a seamless connection. When disassembling panels, twist top connection slightly and lift right panel upward.

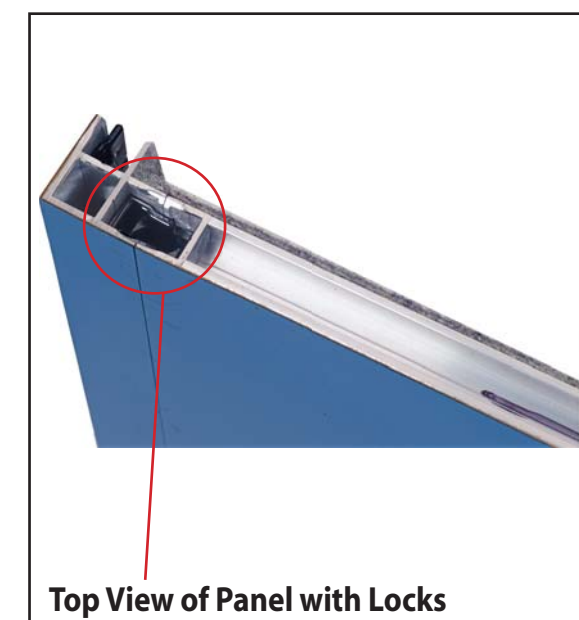

866.652.2100

| Item Number | Description                       |
|-------------|-----------------------------------|
| 9b          | 47.5" h End Cap                   |
| 14          | 23" w x 47.5" h Flat Panel        |
| 16          | 47.5" h Flex Connector            |
| 17          | 10' r x 47.5" h Curve Panel       |
| 18          | 10' r x 47.5" h Small Curve Panel |
| 19a         | Door Stop                         |
| 19          | Lower Section Door                |
| 20          | 47.5" h Flex Connector            |
| 22          | 23" w x 47.5" h Flat Panel        |
| 28          | 47.5" h End Cap                   |

Steps:  
 1) Assemble by starting at panel #9b\* and continue in numerical order.

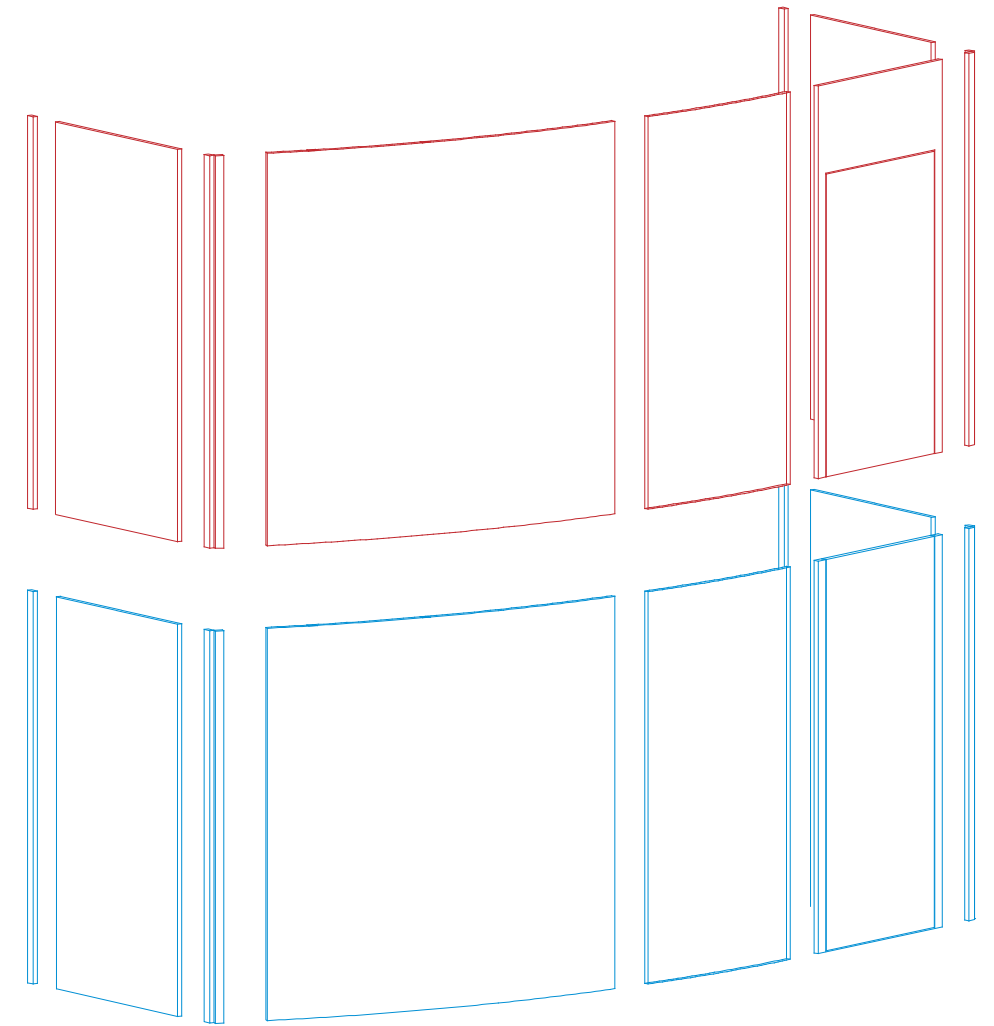
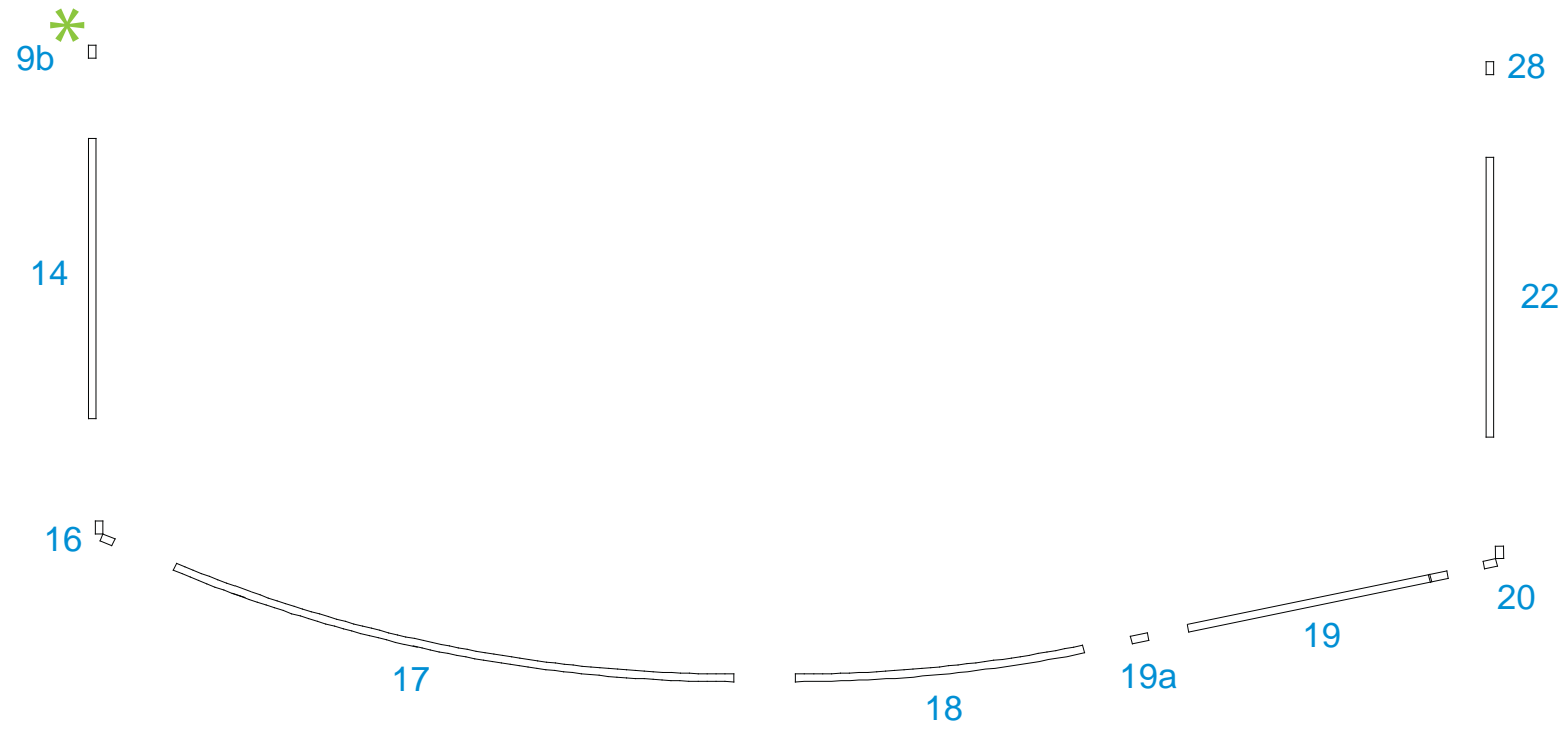

| Item Number | Description                       |
|-------------|-----------------------------------|
| 8           | 47.5" h End Cap                   |
| 14          | 23" w x 47.5" h Flat Panel        |
| 16          | 47.5" h Flex Connector            |
| 17          | 10' r x 47.5" h Curve Panel       |
| 18          | 10' r x 47.5" h Small Curve Panel |
| 19          | Upper Section Door                |
| 20          | 47.5" h Flex Connector            |
| 22          | 23" w x 47.5" h Flat Panel        |
| 28          | 47.5" h End Cap                   |

Steps:  
 1) Assemble by starting at panel #8\* and continue in numerical order.

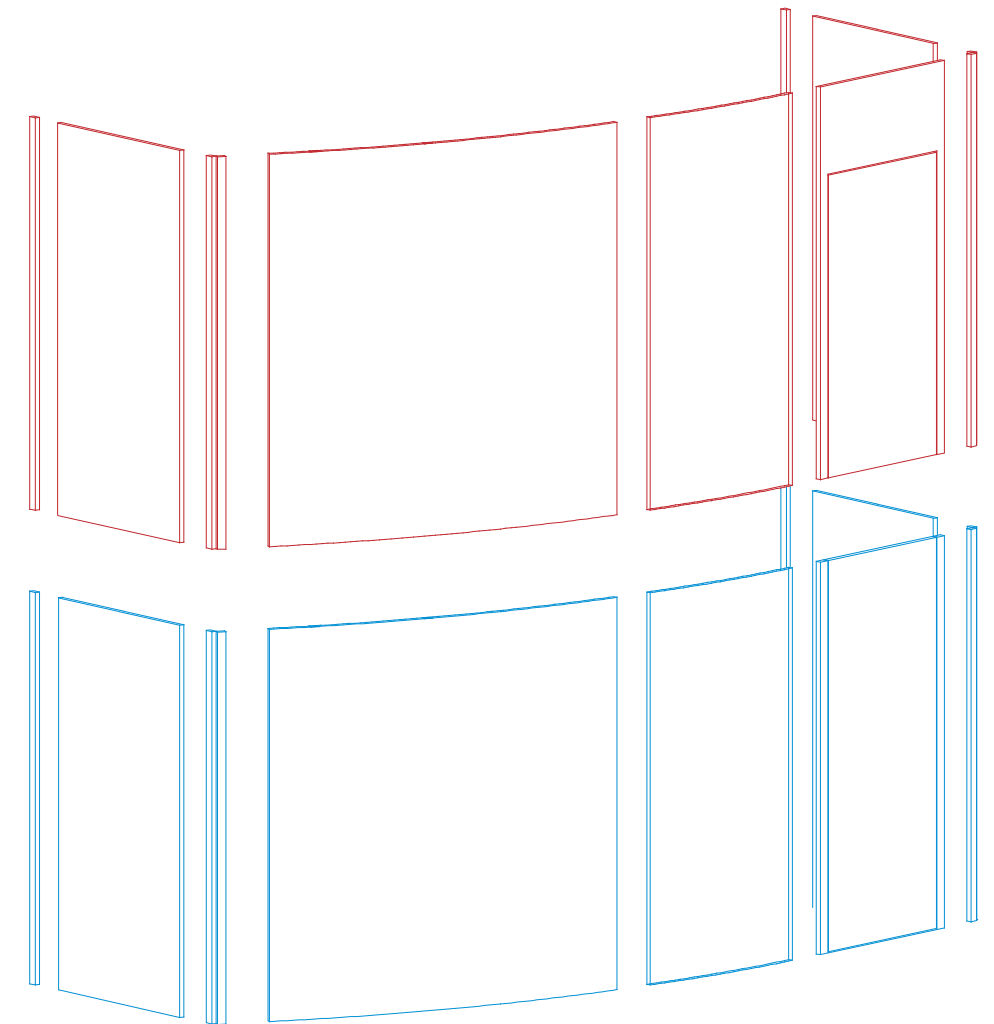
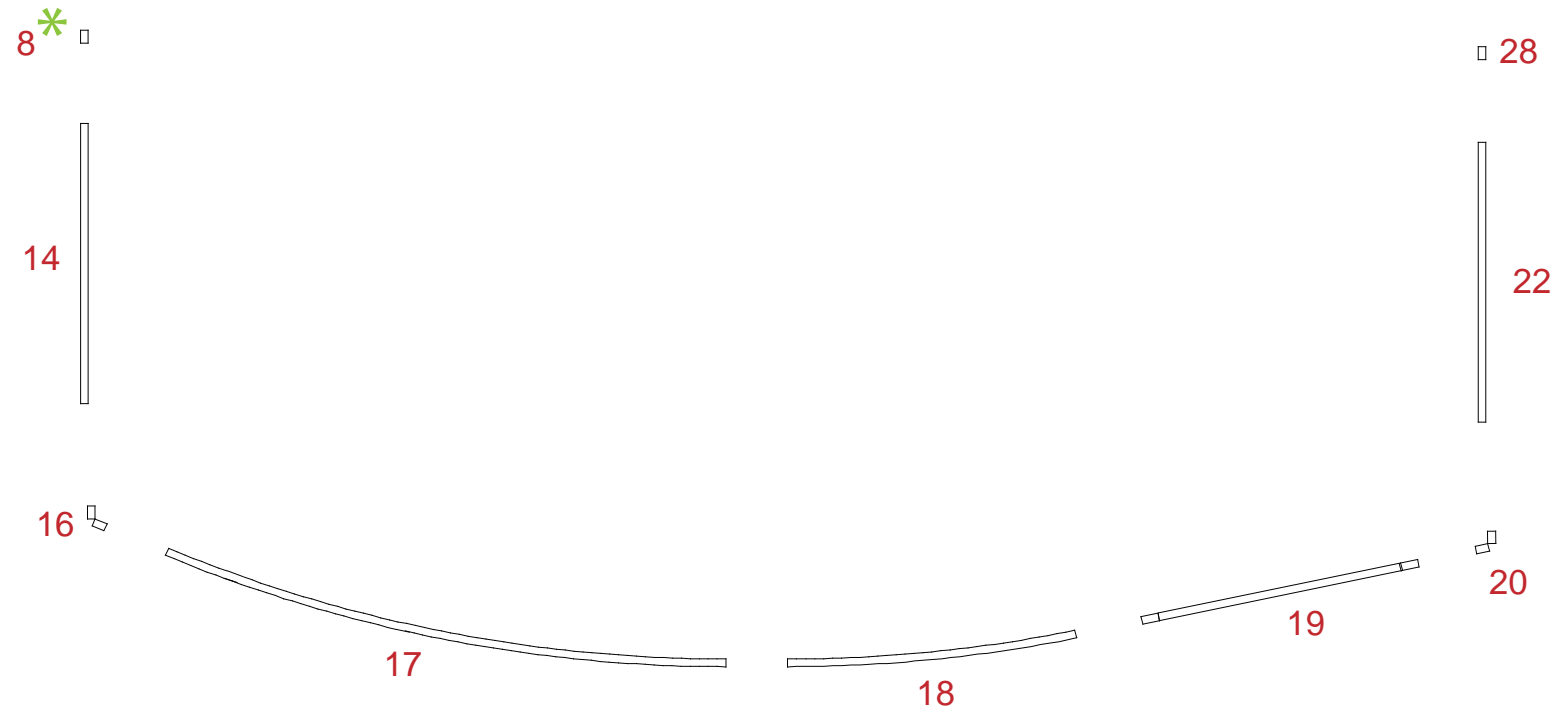

Steps:

- 1) Assemble header pieces together.
- 2) Attach oval sign to assembled header using supplied screws.
- 3) Attach assembled header to backwall where indicated.
- 4) Attach monitor mount to backwall, see Monitor Mount Attachment detail.
- 5) Attach shelves where indicated, see Shelf Attachment detail.

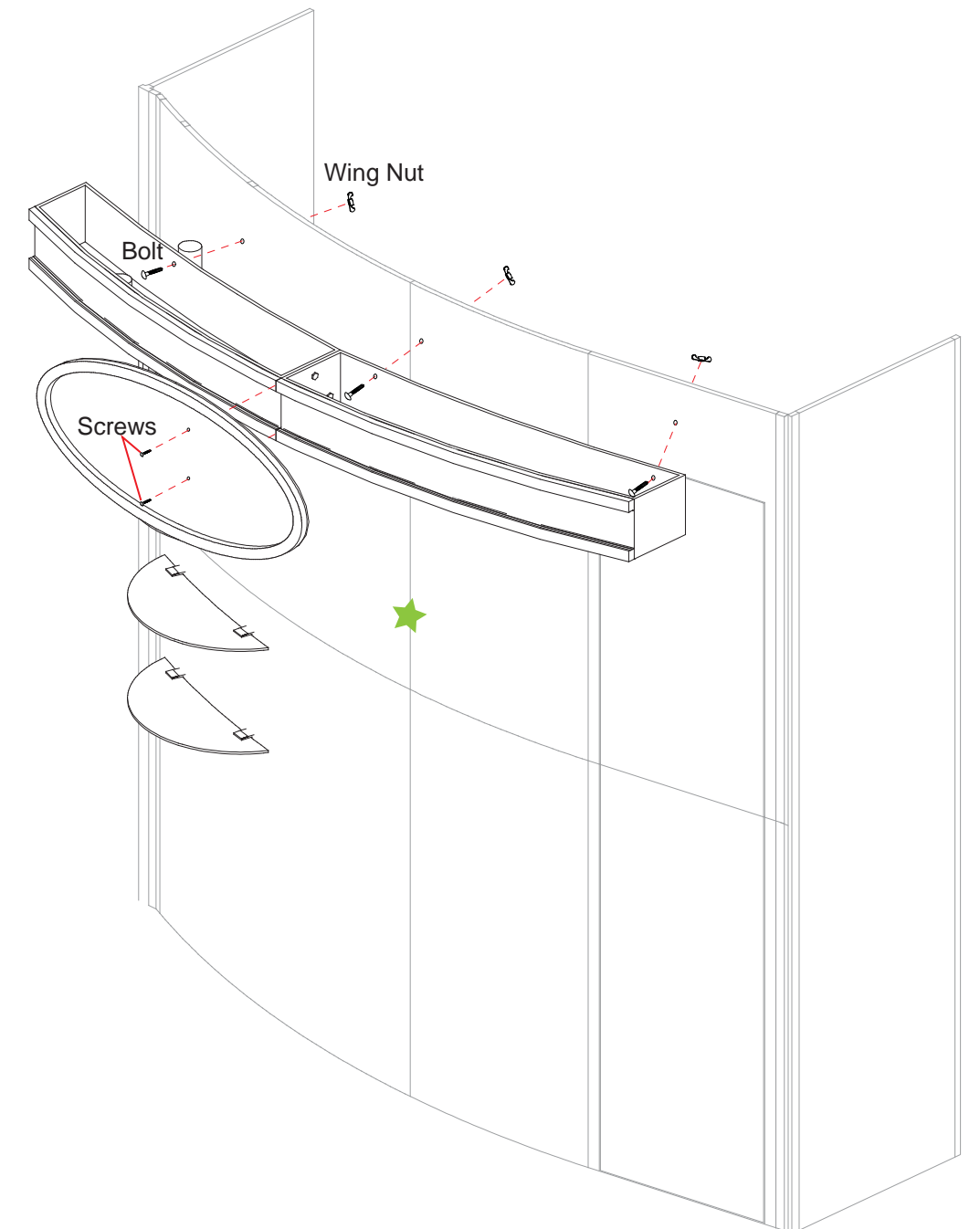
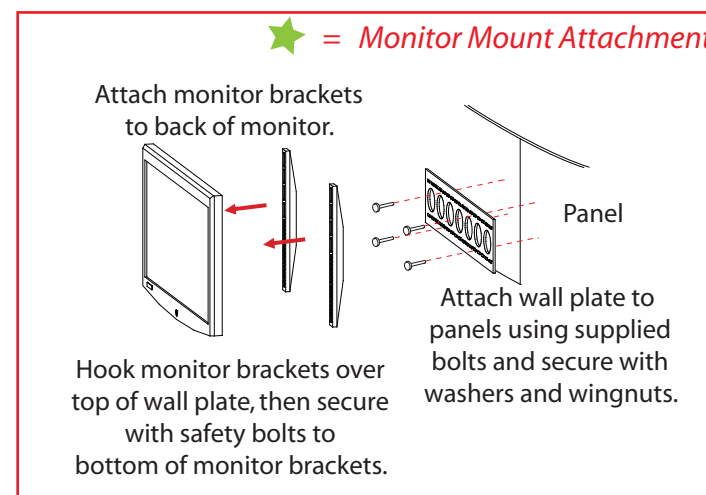
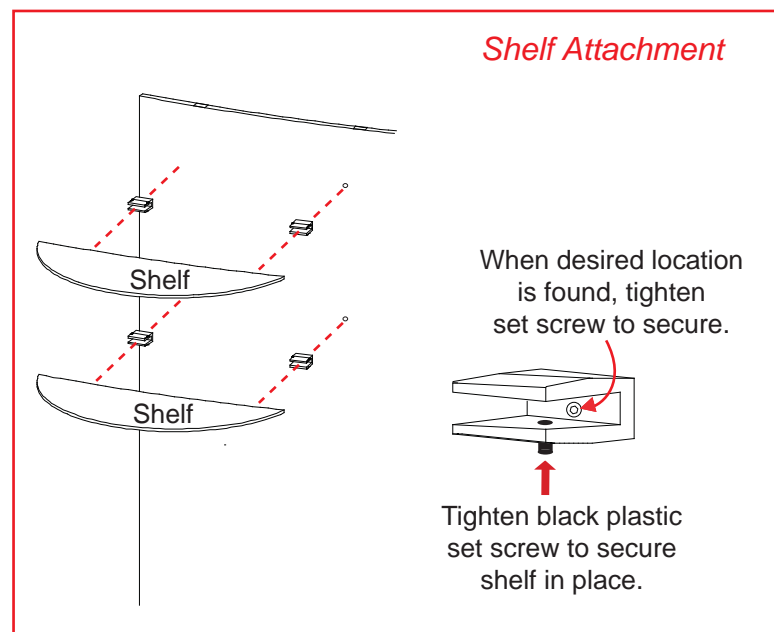
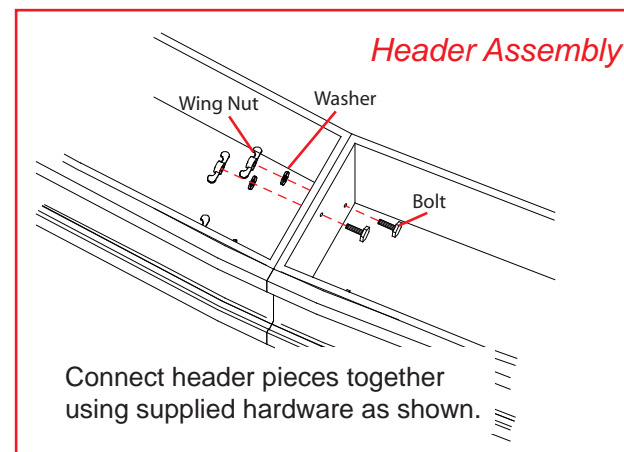

866.652.2100

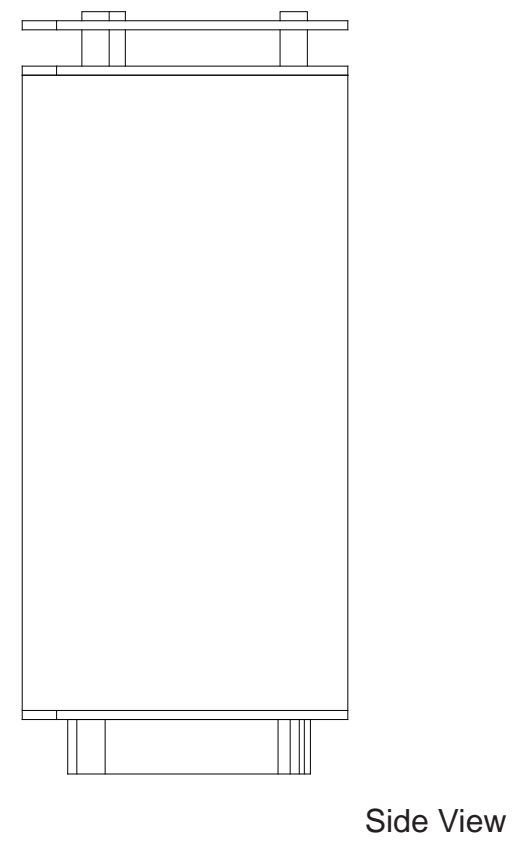
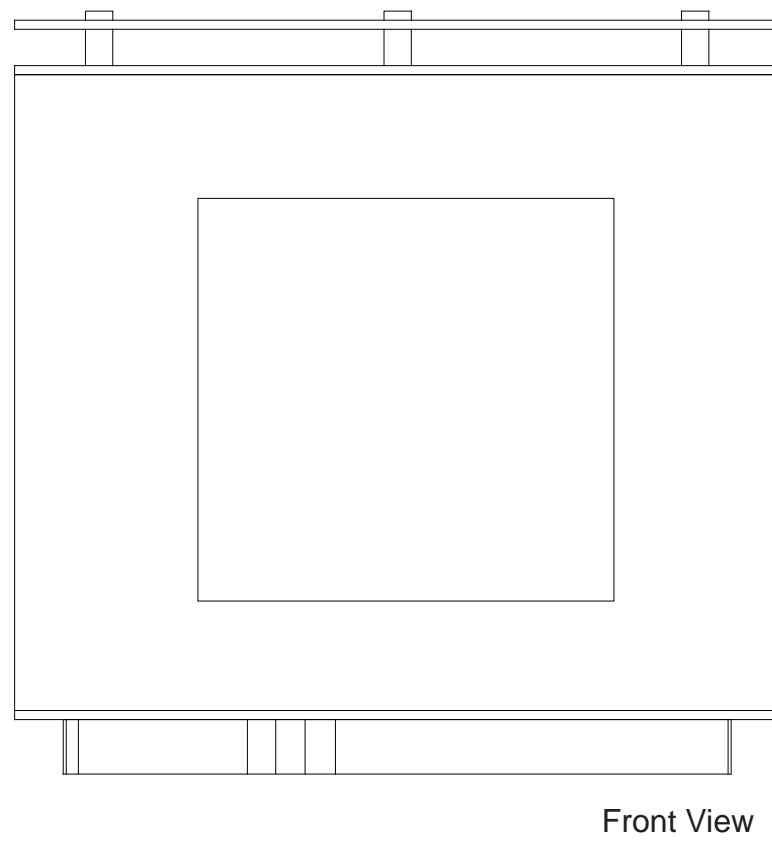
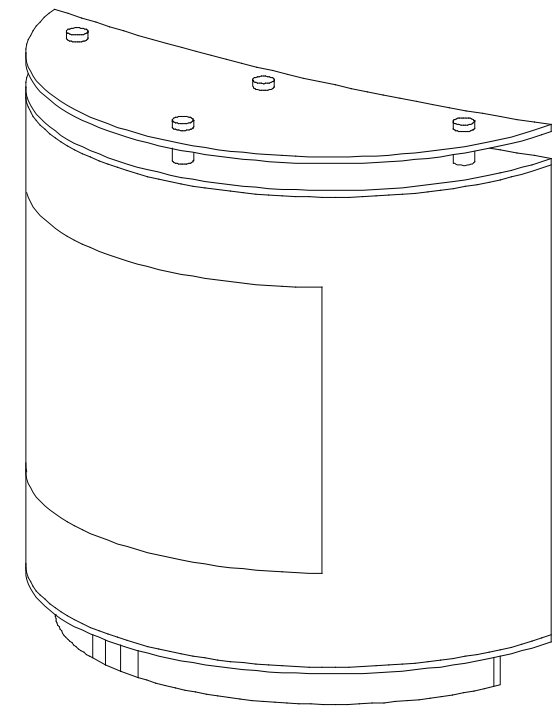
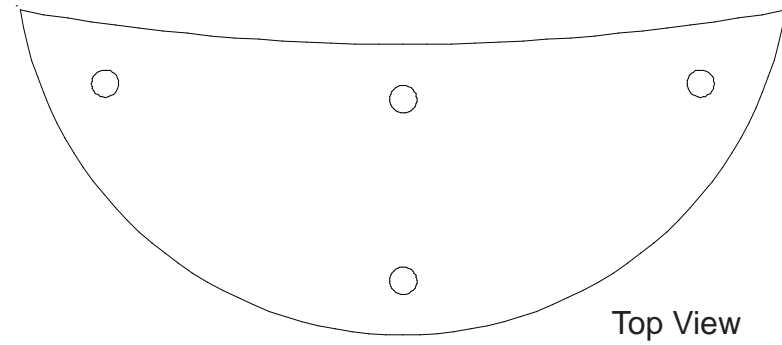

866.652.2100

| Item Number | Description                          |
|-------------|--------------------------------------|
| 30          | 14.125" w x 38" h Flat Panel w/ Door |
| 31          | 9.5" r x 38" h Quarter Curve Panel   |
| 32          | 9.5" r x 38" h Quarter Curve Panel   |
| 33          | 14.125" w x 38" h Flat Panel         |
| 34          | 9.5" r x 38" h Quarter Curve Panel   |
| 35          | 9.5" r x 38" h Quarter Curve Panel   |

Steps:  
 1) Assemble by starting at panel #30\* and continue in numerical order.

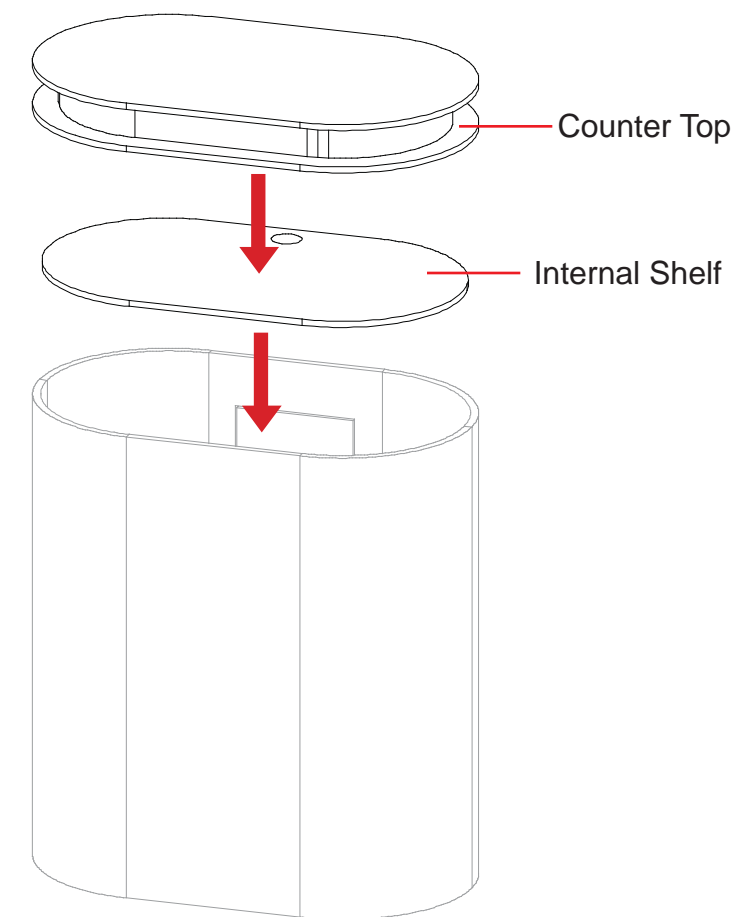
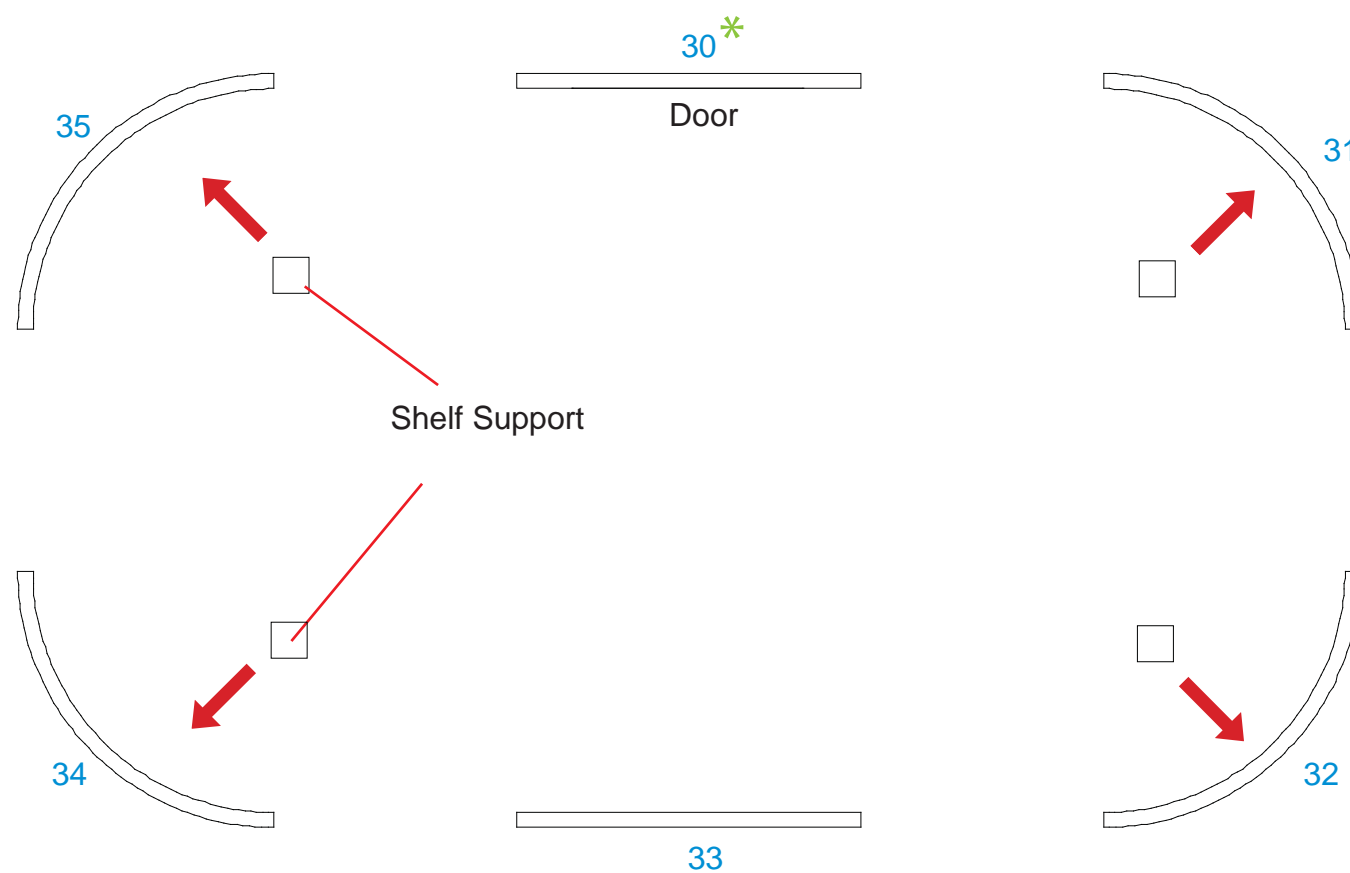
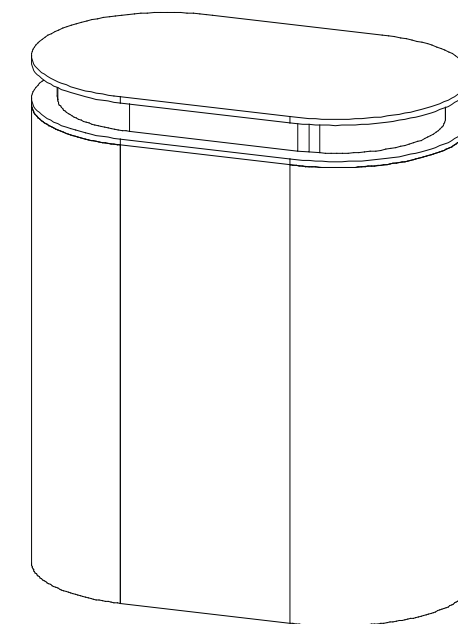

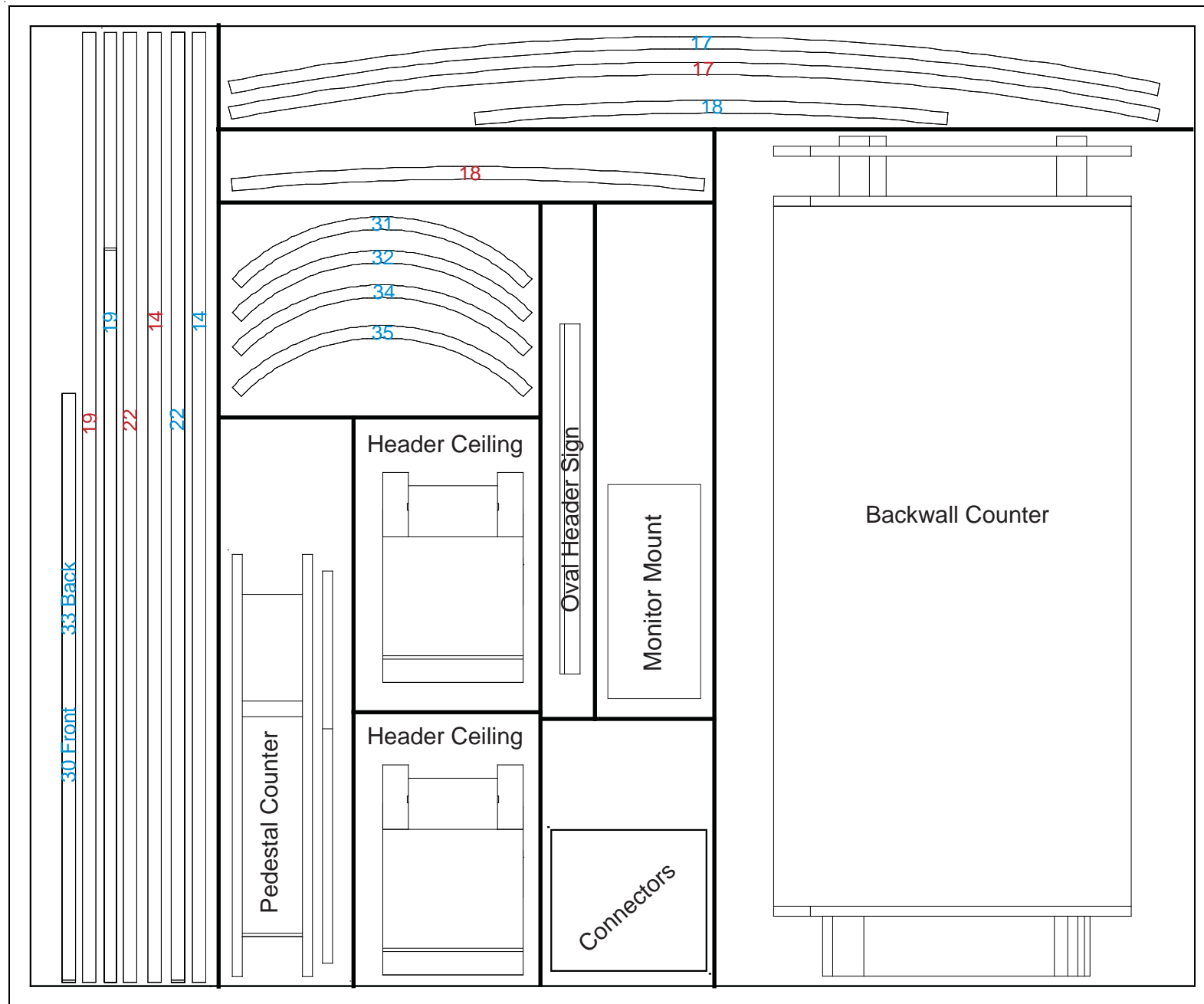

Crate 1