



Modul Extrusion: Part List

Item	Qty.	Description
1	1	Base Plate
2	2	Right Leg Extrusion
3	2	Left Leg Extrusion
4	1	Vertical Extrusion for Monitor Mount Attachment

EURO LT System: Part List

Item	Qty.	Description
1	1	Tapered Panel w/ Door
2	1	Side Panel
3	1	Tapered Panel
4	1	Side Panel

Steps:

- 1) Attach left leg extrusions [3] to panel [2] and right leg extrusions [2] to panel [4] using supplied screws, see detail illustration below.
- 2) Attach leg assemblies to base plate [1] using bolts as shown.

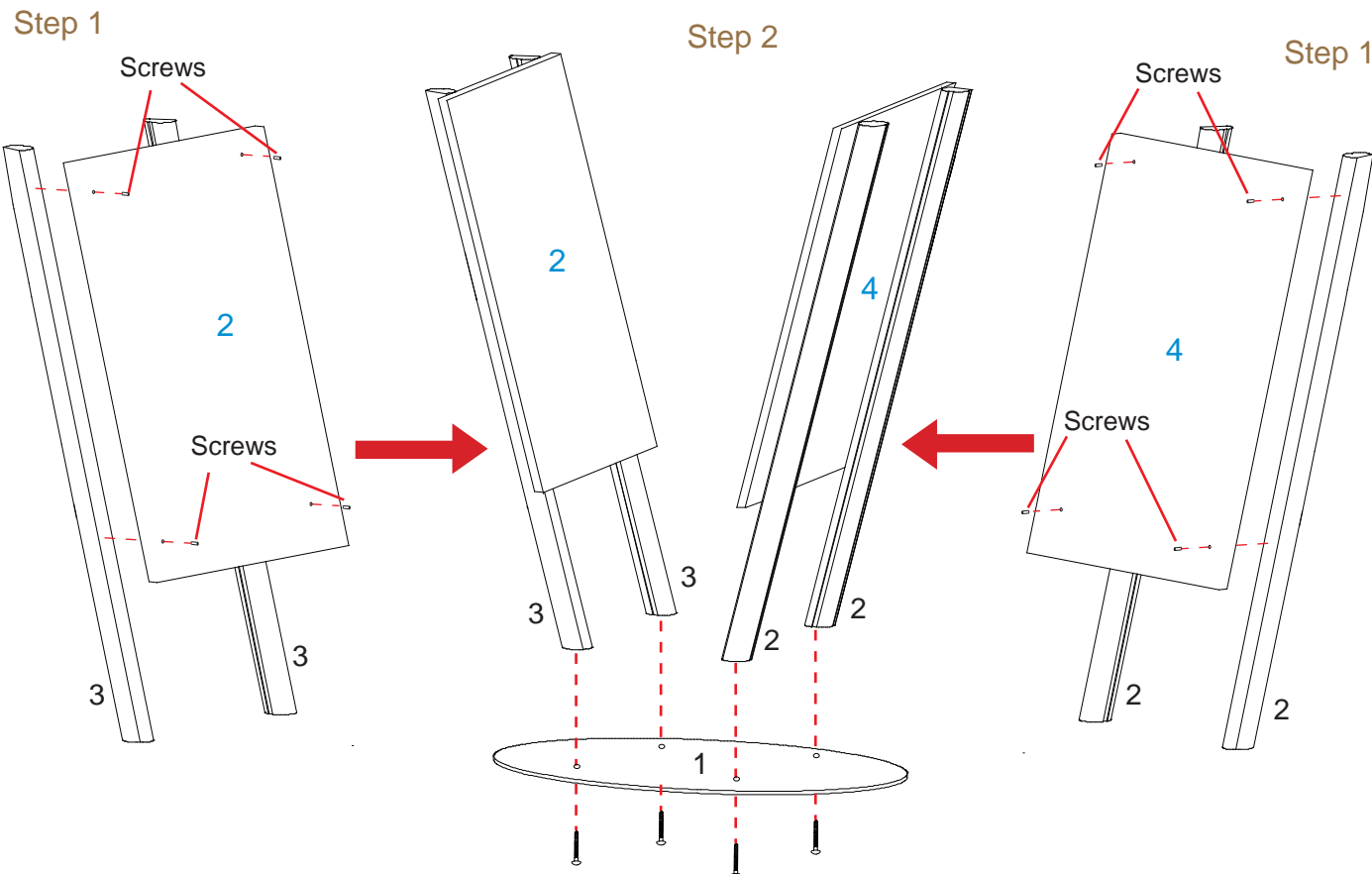

Steps (Cont'd):

- 3) Assemble panels [1 and 3] to panels [2 and 4] as shown.
- 4) Attach pins to back of panels [1 and 3], then set floor atop pins.
- 5) Velcro shelf supports to inside of assembled base, then set shelf atop supports.
- 6) Attach plate to underside of counter, and secure with provided screws.
- 7) Attach vertical extrusion [4] to counter using supplied bolt.
- 8) Set assembled counter atop assembled base.
- 9) Attach monitor mount to vertical extrusion where indicated, see monitor mount attachment detail.

*** Monitor Mount Attachment**
Attach monitor mount to vertical extrusions after assembly.

Slide Mount into Groove of Vertical Extrusion. Tighten Setscrew. Attach top Plate and tighten screws.

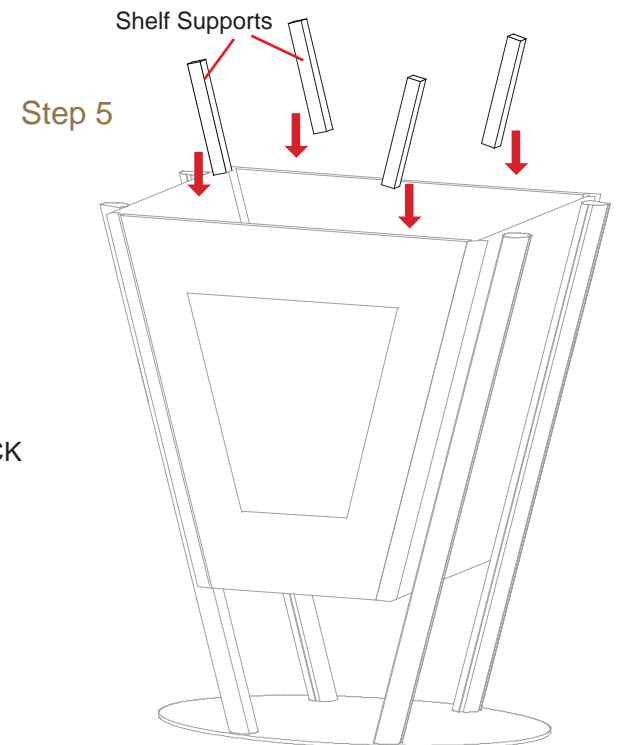
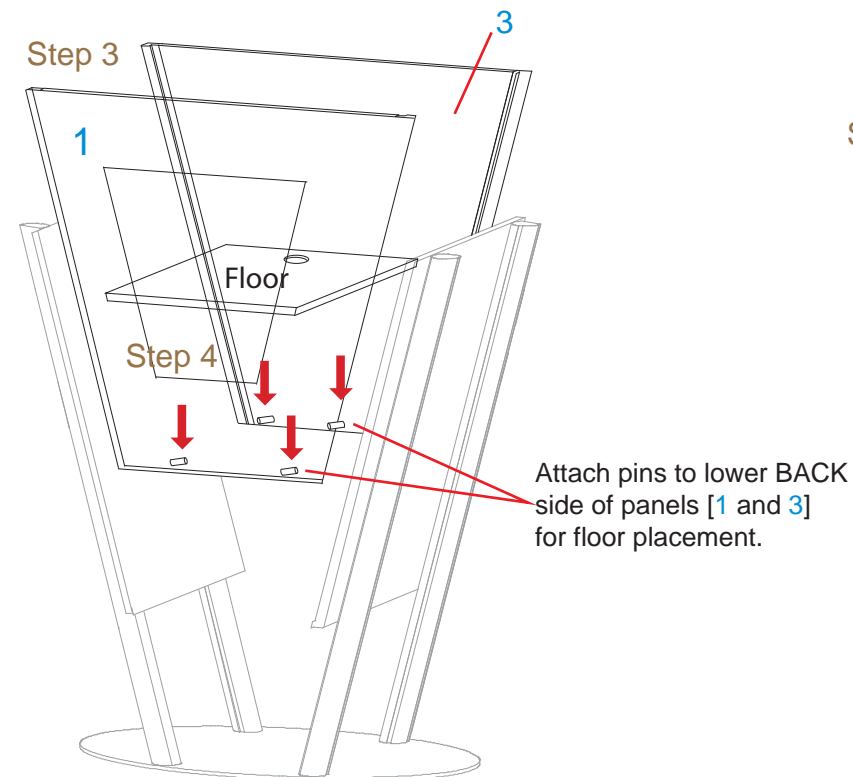
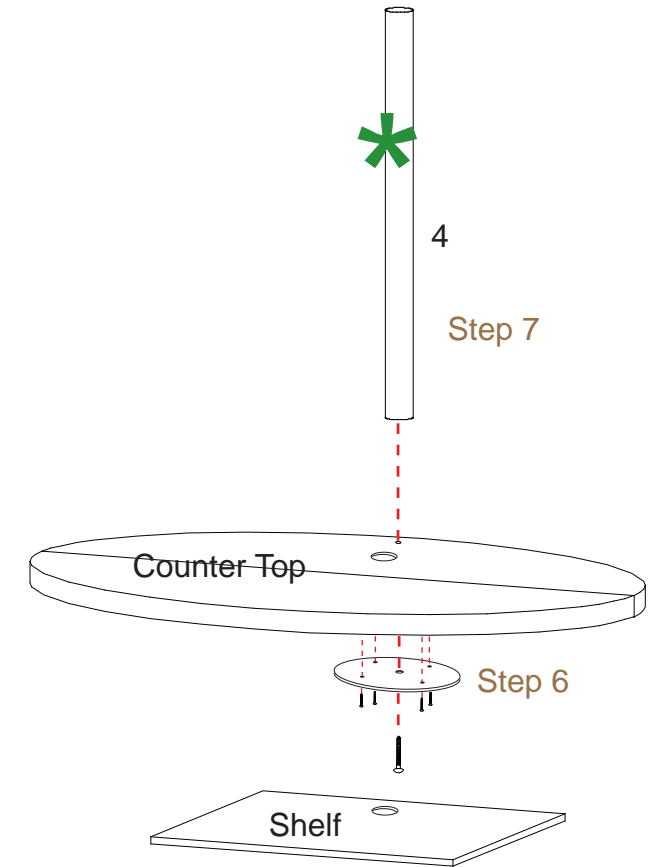

WHEN DISASSEMBLING ALUMINUM EXTRUSION, TIGHTEN ALL SETSCREWS AND LOCKS TO PREVENT LOSS DURING SHIPPING



General Setup Instructions for Panel System

Using Your Setup Instructions

The Euro LT Hybrids Setup Instructions are created specifically for your configuration. They are laid out sequentially in levels, including exploded views, and a logical series of detailed steps to assemble the main structure and components. We encourage you to study the instructions **before** attempting to assemble your exhibit.

Each page reminds you to tighten the setscrews after disassembling your exhibit to prevent loss of the locks and setscrews (see below in RED). This is VERY IMPORTANT.

Cleaning and Packing Your Display

- 1) Use care when cleaning aluminum extrusion or acrylic inserts. Use only non-abrasive cleaners.
- 2) When cleaning laminate inserts, countertops, or panels use mild cleansers and a soft material such as cotton.
- 3) Keep all display components away from extreme heat and long exposure to sunlight to avoid warping and fading.
- 4) Retain all packing material. It will make re-packing much easier and will reduce the likelihood of shipping damage.

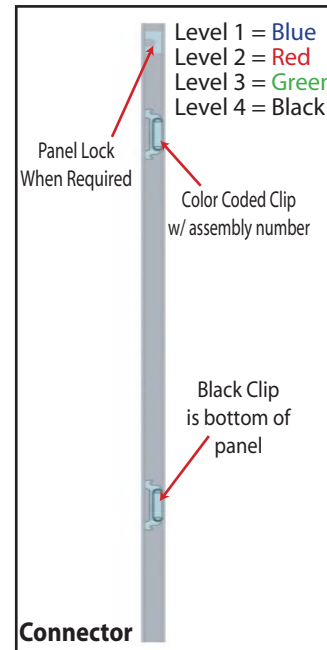

Connector
Each component has 2 clips, the lower clip is ALWAYS black. The top clip is color coded to distinguish the level. The color coded clip also contains the numbered label.

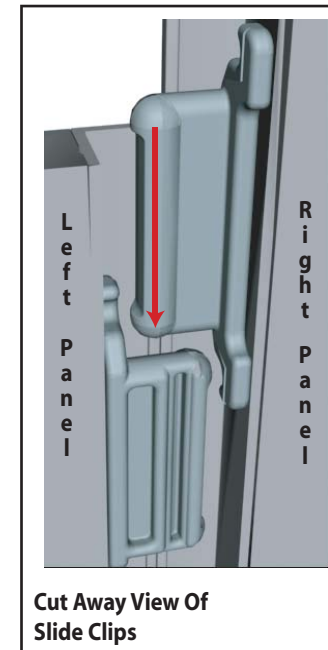

Cut Away View Of Slide Clips
Components connect together by aligning them and sliding downward connecting clips together.

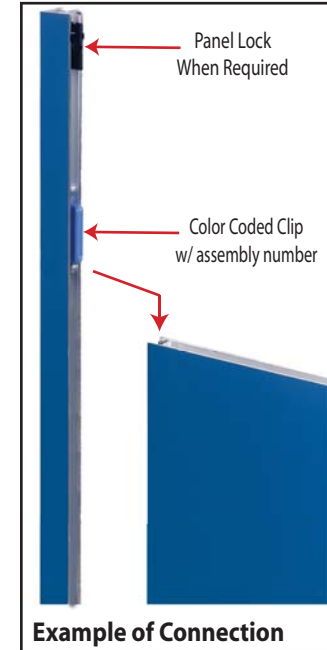

Example of Connection
Configurations are assembled from left to right, usually starting with #1 and following the numbered sequence.

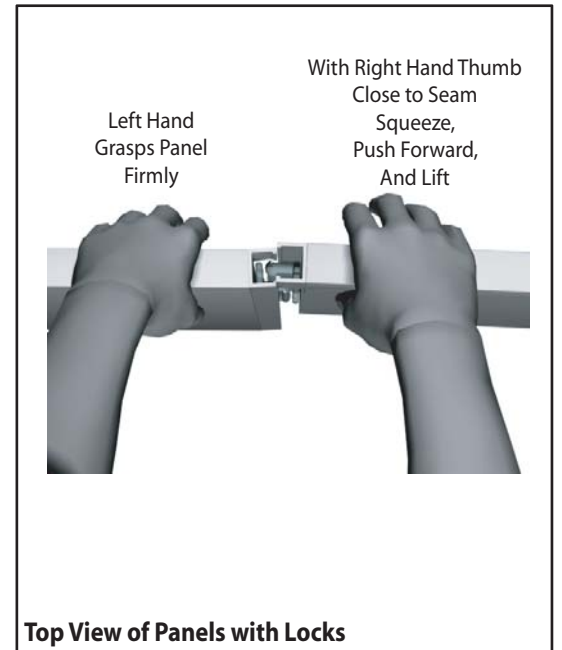

Top View of Panels with Locks
The first level of components contains panel locks that are located at the top of the panel for extra stability and a seamless connection. When disassembling panels, twist top connection slightly and lift right panel upward.

General Setup Instructions for Extrusion System



The Tool
Most exhibits can be assembled with the supplied Hex Key Tool. Occasionally, a flat head screwdriver may be required.



Typical Connection
Most horizontal extrusion connections have a patented expandable lock. This lock inserts into the groove of an opposing extrusion. Tightening the lock with the Hex Key Tool expands the lock and creates a strong positive connection.



Typical Connection (cont'd)

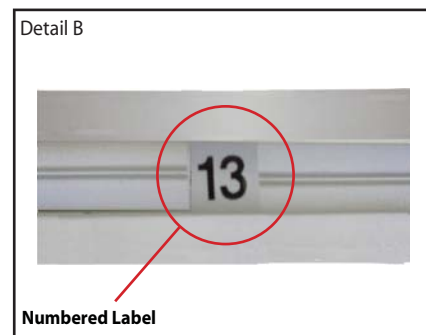

Numbered Label
Each extrusion contains a numbered label which corresponds with setup instructions. The label is located within a groove of the extrusion (when possible). With extrusion components the labels contain Black numbers unless otherwise specified.



Horizontal Inline Connection (remove only one setscrew)
Remove only (1) setscrew when disassembling. Replace setscrew in extrusion after assembling it. Before packing, replace setscrew in extrusion to avoid losing it.

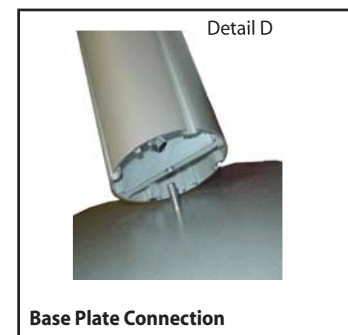

Base Plate Connection
Attach base plate to round or square vertical extrusion using the bolt provided. Be careful not to strip the threads.

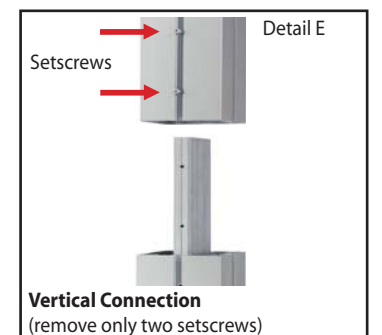

Vertical Connection (remove only two setscrews)
When vertical extrusions are packed in portable cases rather than crates or tubs, they must be broken down into smaller sections which then require assembly.

Remove only (2) setscrews when disassembling. Replace setscrews in extrusion after assembling it. Before packing, replace setscrews in extrusion to avoid losing them.

WHEN DISASSEMBLING ALUMINUM EXTRUSION, TIGHTEN ALL SETSCREWS AND LOCKS TO PREVENT LOSS DURING SHIPPING

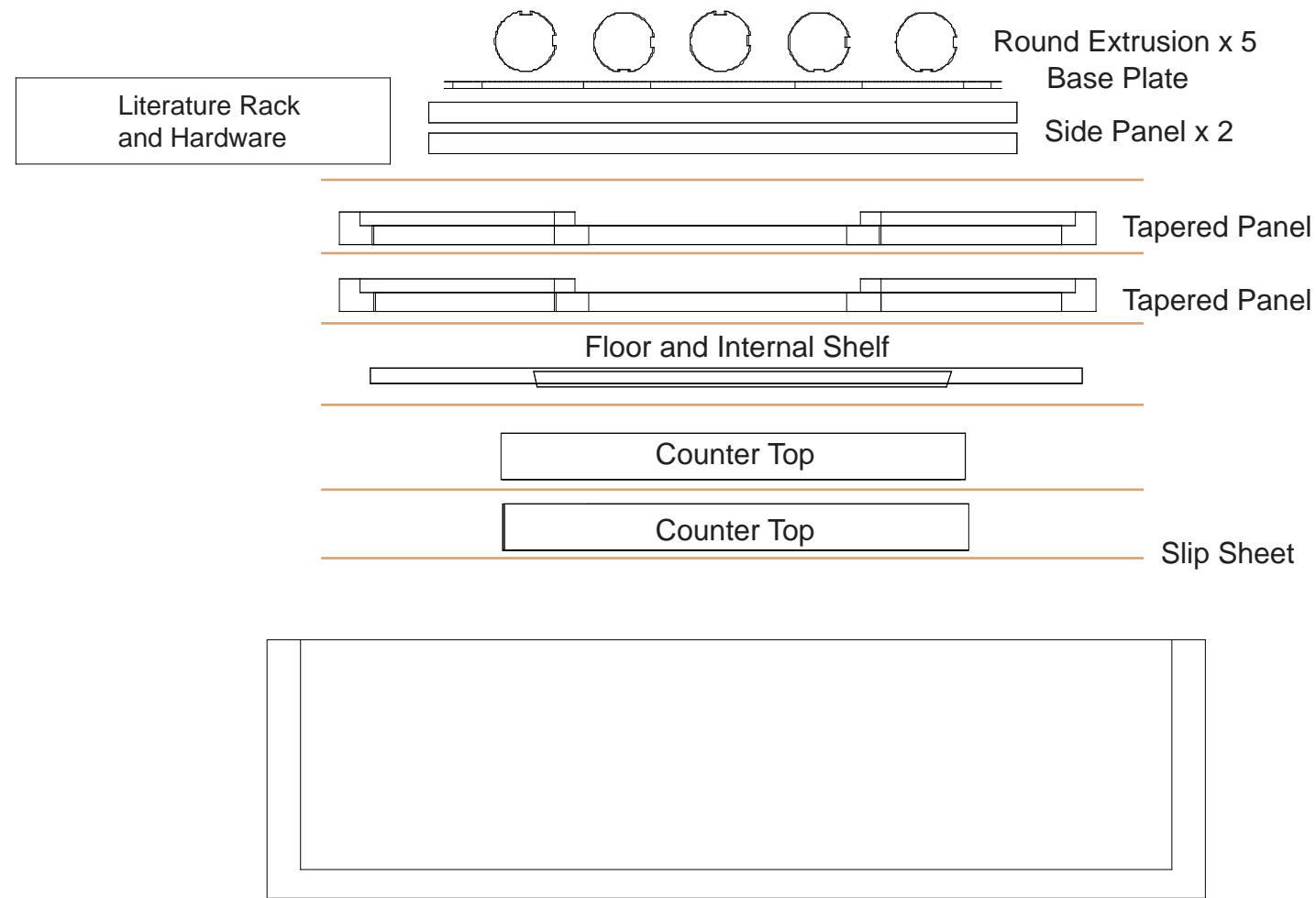

WHEN DISASSEMBLING ALUMINUM EXTRUSION, TIGHTEN ALL SETSCREWS AND LOCKS TO PREVENT LOSS DURING SHIPPING