

WHEN DISASSEMBLING ALUMINUM EXTRUSION, TIGHTEN ALL SETSCREWS AND LOCKS TO PREVENT LOSS DURING SHIPPING

visionary™ IDESIGNS

Using Your Setup Instructions

The Visionary Designs Setup Instructions are created specifically for your configuration. They are laid out sequentially, including an exploded view of the entire display, and then a logical series of detailed steps to assemble the main structure and components. We encourage you to study the instructions **before** attempting to assemble your exhibit.

Each page reminds you to tighten the setscrews after disassembling your exhibit to prevent loss of the locks and setscrews (see below in RED). This is **VERY IMPORTANT**.

Cleaning and Packing Your Display

- 1) Use care when cleaning aluminum extrusion or acrylic inserts. Use only non-abrasive cleaners.
- 2) When cleaning laminate inserts or countertops, use mild cleansers and a soft material such as cotton.
- 3) Keep all display components away from extreme heat and long exposure to sunlight to avoid warping and fading.
- 4) Retain all packing material. It will make re-packing much easier and will reduce the likelihood of shipping damage.



The Tool

Most Visionary Designs exhibits can be assembled with the supplied Hex Key Tool. Occasionally, a flat head screwdriver may be required.

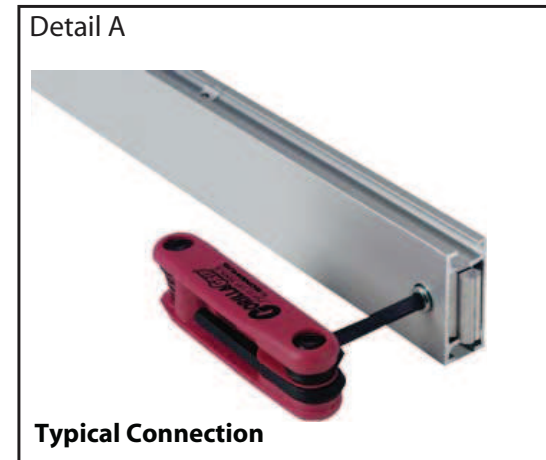

Typical Connection

Most horizontal extrusion connections have a patented expandable lock. This lock inserts into the groove of an opposing extrusion. Tightening the lock with the Hex Key Tool expands the lock and creates a strong positive connection.



Typical Connection (cont'd)

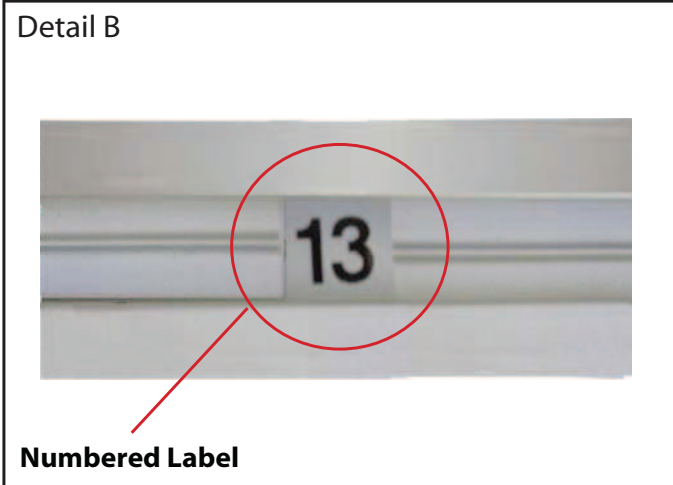

Detail B

Numbered Label

Each extrusion contains a numbered label which corresponds with setup instructions. The label is located within a groove of the extrusion (when possible). With Visionary Designs the labels contain Black numbers unless otherwise specified.



Detail C

Horizontal Inline Connection (remove only one setscrew)

Remove only (1) setscrew when disassembling. Replace setscrew in extrusion after assembling it. Before packing, replace setscrew in extrusion to avoid losing it.

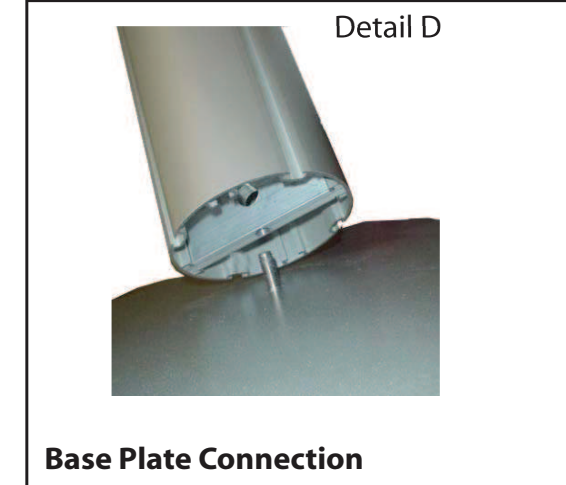

Detail D

Base Plate Connection

Attach base plate to round or square vertical extrusion using the bolt provided. Be careful not to strip the threads.

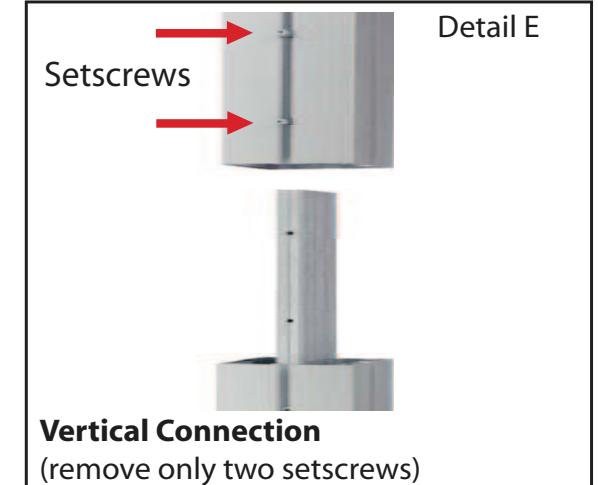

Detail E

Vertical Connection
(remove only two setscrews)

When vertical extrusions are packed in portable cases rather than crates or tubs, they must be broken down into smaller sections which then require assembly.

Remove only (2) setscrews when disassembling. Replace setscrews in extrusion after assembling it. Before packing, replace setscrews in extrusion to avoid losing them.

WHEN DISASSEMBLING ALUMINUM EXTRUSION, TIGHTEN ALL SETSCREWS AND LOCKS TO PREVENT LOSS DURING SHIPPING

866.652.2100

Item	Quantity	Description
1	4	Oval Base Plate
2	2	42" Square Vertical Extrusion
3	2	42" Square Vertical Extrusion
4	2	42" Square Vertical Extrusion
5	2	42" Square Vertical Extrusion with Canopy Attachments
6a/6b	1/1	36.125" Curved Horizontal Extrusion w/ Velcro Attached to Top of Extrusion
7a/7b	1/1	36.125" Curved Horizontal Extrusion w/ Velcro Attached to Bottom of Extrusion
8a/8b	1/1	42" Horizontal Extrusion w/ Velcro Attached to Top of Extrusion
9a/9b	1/1	42" Horizontal Extrusion w/ Velcro Attached to Bottom of Extrusion
10a/10b	1/1	36.125" Curved Horizontal Extrusion w/ Velcro Attached to Top of Extrusion
11a/11b	1/1	36.125" Curved Horizontal Extrusion w/ Velcro Attached to Bottom of Extrusion
12	4	19" Tapered Horizontal Extrusion
13	4	40" Round Vertical Extrusion

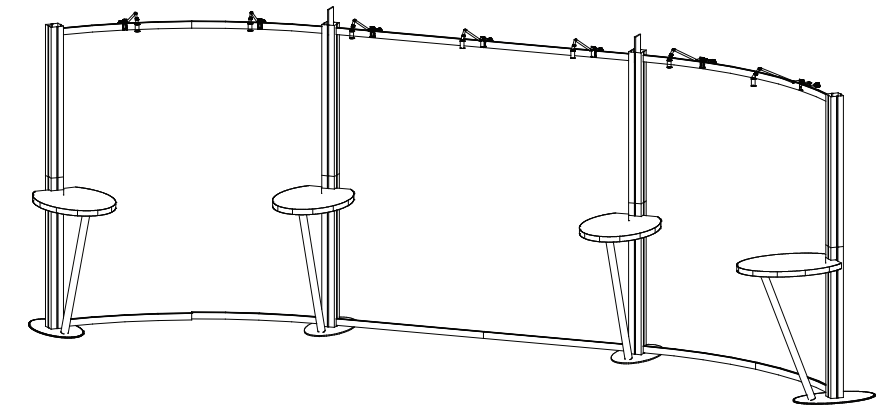
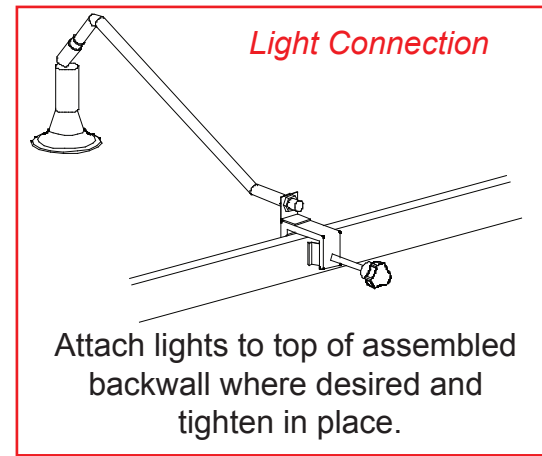

Steps:

- 1) Attach vertical extrusions [2], [3] and round vertical extrusion [13] to oval base plates [1], see DetailD on General Information Page.
- 2) Attach tapered horizontal extrusions [12] between square vertical extrusions and round vertical extrusions, as shown.
- 3) Attach vertical extrusions [4] to vertical extrusions [2] and vertical extrusions [5] to vertical extrusions [3].
- 4) Attach curved horizontal extrusions and horizontal extrusions together [6a to 6b, 7a to 7b, 8a to 8b, 9a to 9b, 10a to 10b and 11a to 11b].
- 5) Attach assembled horizontal extrusions (assembled in step 4), between square vertical extrusions [2/4] and [3/5], as shown.
- 6) Place counter tops onto horizontal extrusion [11], with notched side fitting to square vertical extrusion, and secure with thumbscrews.

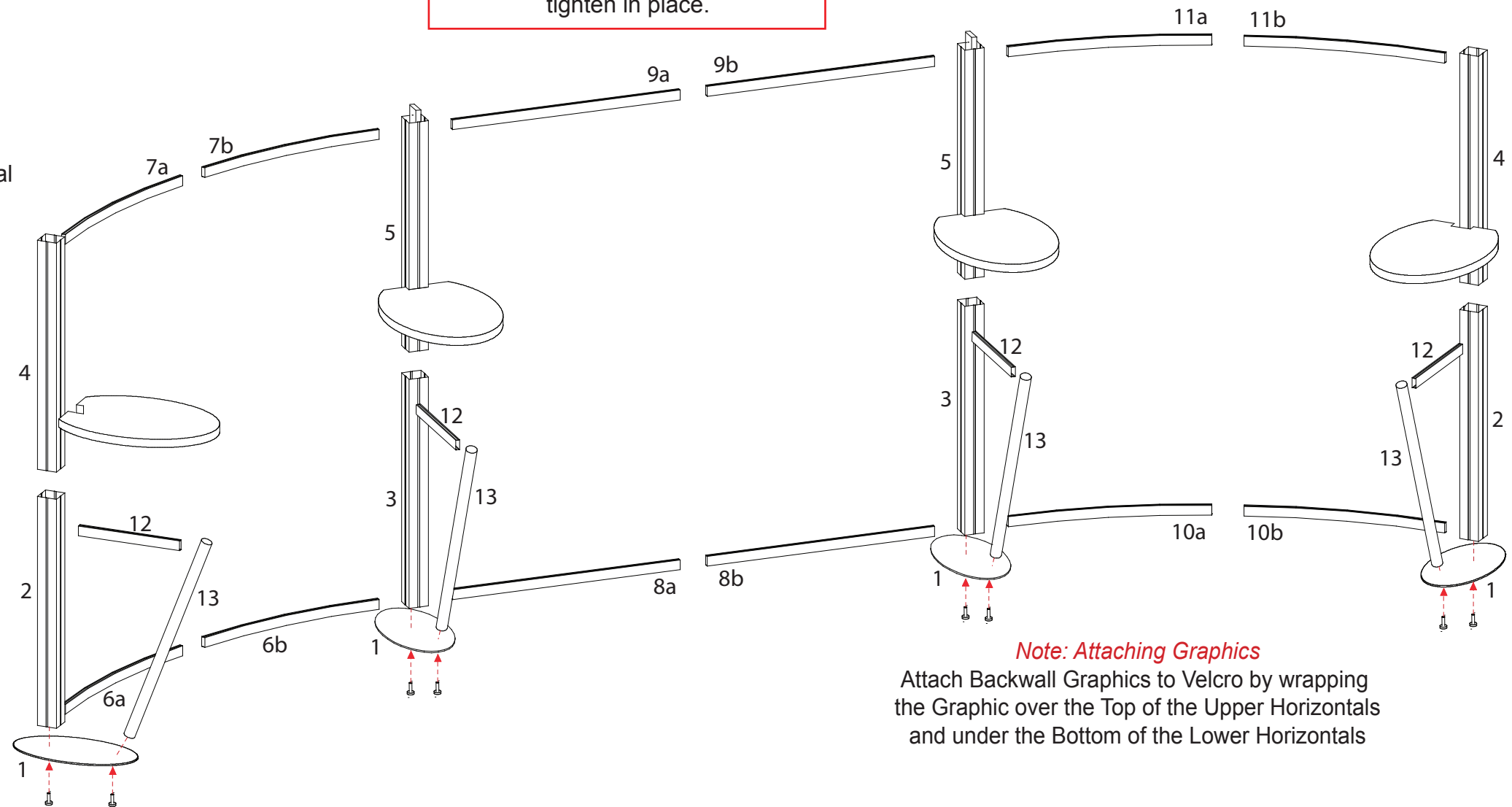

Note: Attaching Graphics
 Attach Backwall Graphics to Velcro by wrapping the Graphic over the Top of the Upper Horizontals and under the Bottom of the Lower Horizontals

WHEN DISASSEMBLING ALUMINUM EXTRUSION, TIGHTEN ALL SETSCREWS AND LOCKS TO PREVENT LOSS DURING SHIPPING

Item	Quantity	Description
A	1	38" Round extrusion
AB	1	38" Round extrusion
B	1	38" Round extrusion
C	1	38" Round extrusion
CD	1	38" Round extrusion
D	1	38" Round extrusion
E	2	14.25" Round extrusion

Steps:

- 1) Connect (A) round extrusion to (AB) round extrusion.
- 2) Connect (AB) round extrusion to (B) round extrusion.
- 3) Connect (C) round extrusion to (CD) round extrusion.
- 4) Connect (CD) round extrusion to (D) round extrusion.
- 5) Connect (A) round extrusion and (D) round extrusion to (E) extrusion.
- 6) Connect (B) round extrusion and (C) round extrusion to (E) extrusion.
- 7) Attach Canopy Assembly to Vertical extrusions with Canopy attachments.

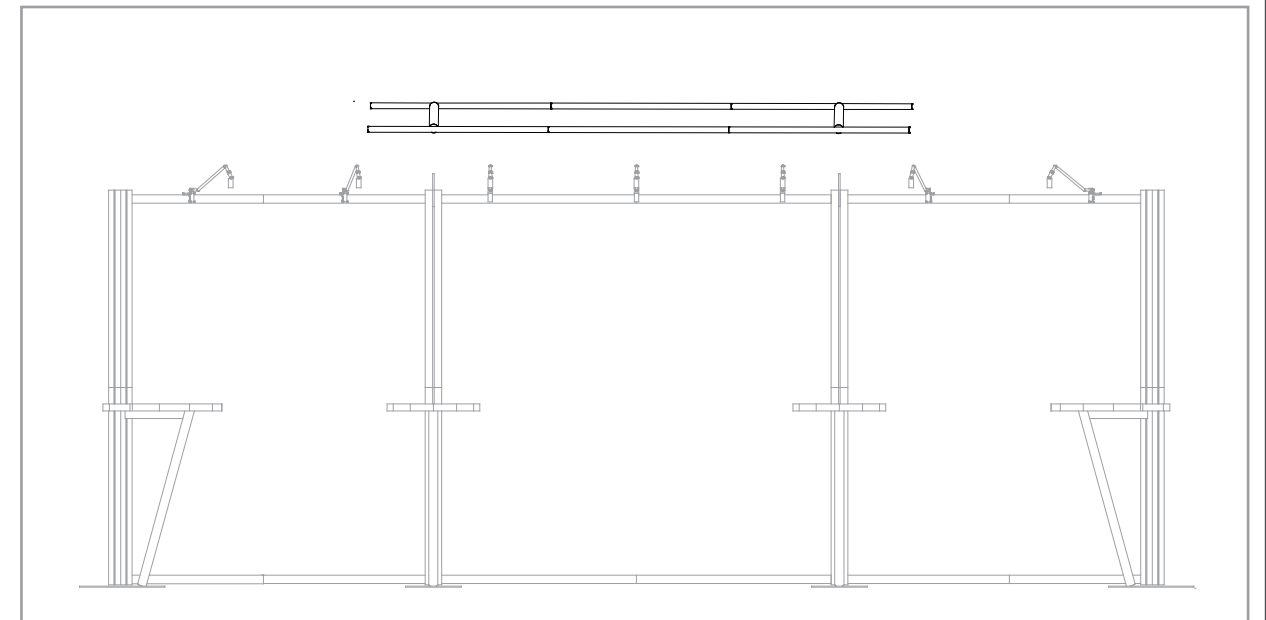
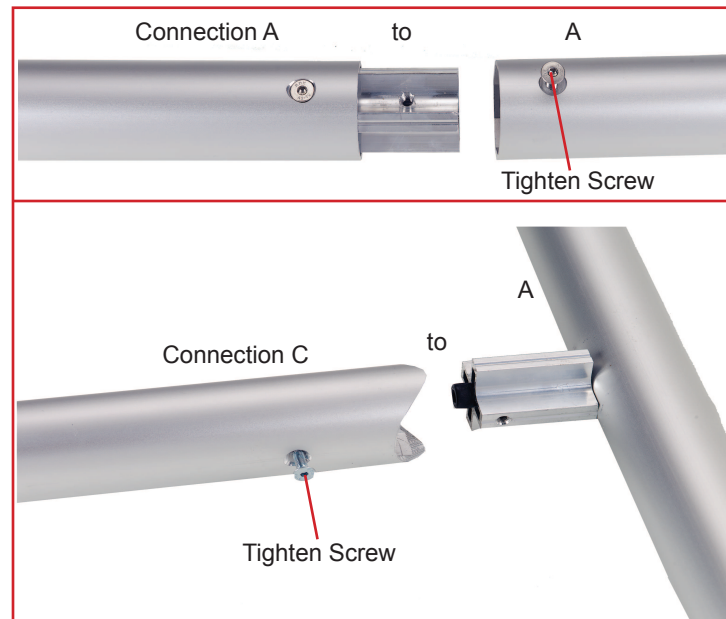
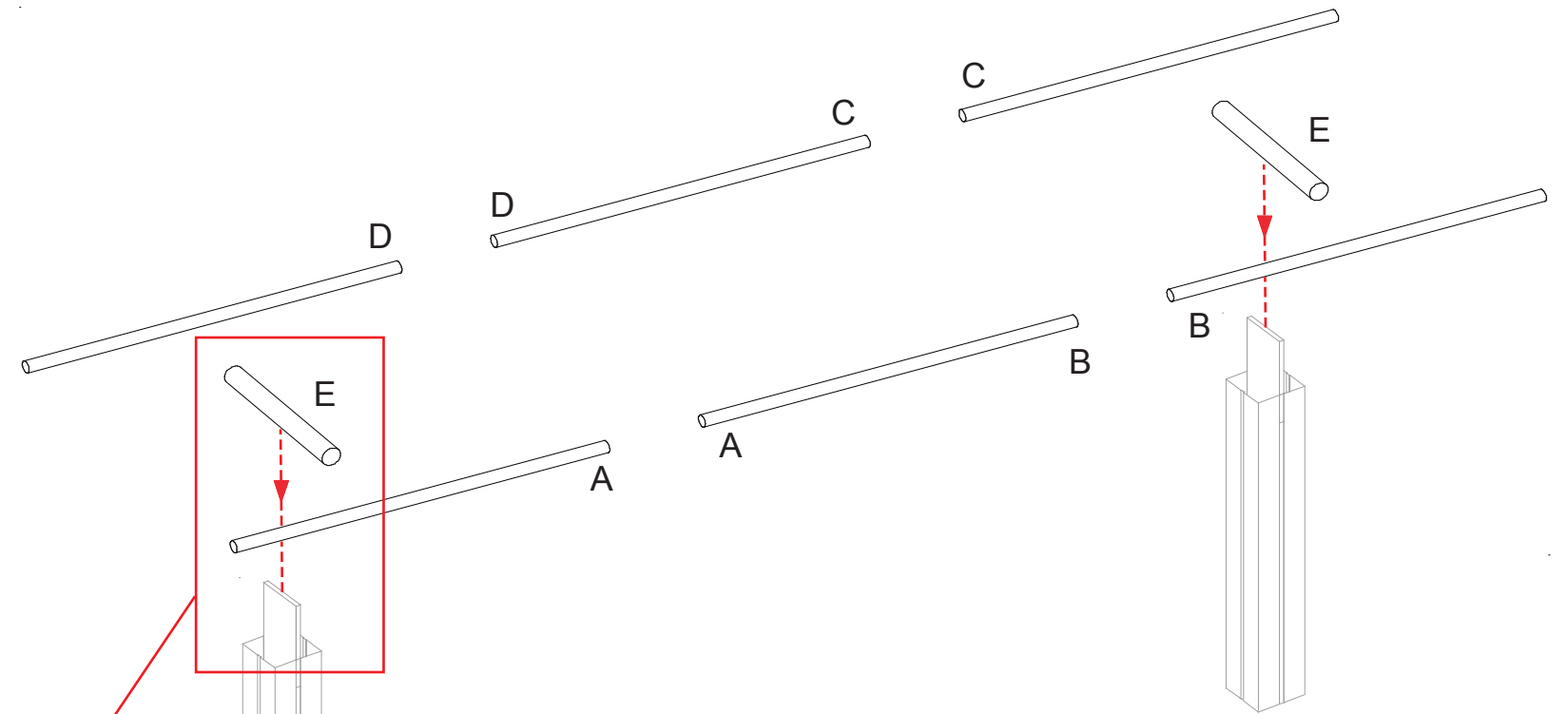

WHEN DISASSEMBLING ALUMINUM EXTRUSION, TIGHTEN ALL SETSCREWS AND LOCKS TO PREVENT LOSS DURING SHIPPING

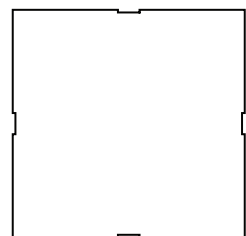

42”h Square Extrusion

Qty. : 8

Located in Case : _____



36.125”h Curved Extrusion

Qty. : 8

Located in Case : _____

Additional Accessories:

_____ in case _____

_____ in case _____

_____ in case _____

_____ in case _____

_____ in case _____

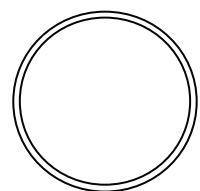

Tapered Counter Support

Qty. : 4

Located in Case : _____



42”h Extrusion

Qty. : 4

Located in Case : _____

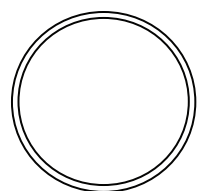

Standard Canopy Extrusion

Qty. : 6

Located in Case : _____

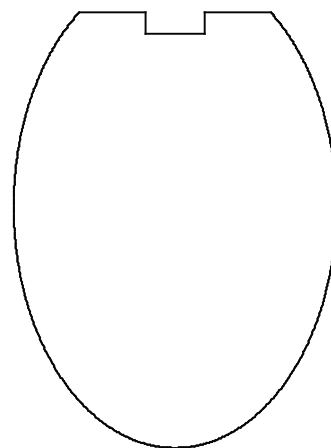

Workstation Counter Top

Qty. : 4

Located in Case : _____

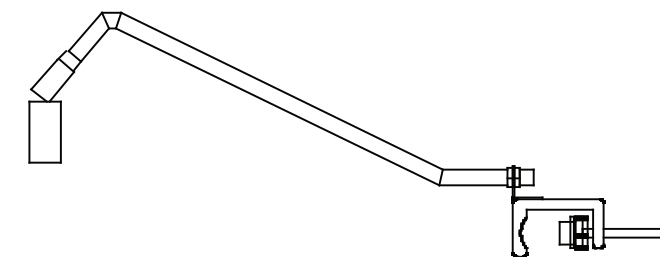

Halogen Light

Qty. : 7

Located in Case : _____

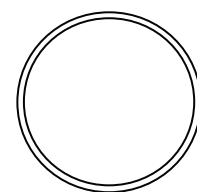

Standard Canopy Center Extrusion

Qty. : 3

Located in Case : _____

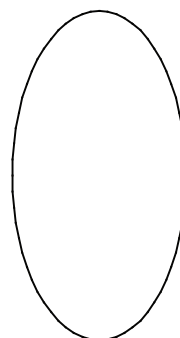

Oval Base Plate

Qty. : 4

Located in Case : _____

WHEN DISASSEMBLING ALUMINUM EXTRUSION, TIGHTEN ALL SETSCREWS AND LOCKS TO PREVENT LOSS DURING SHIPPING