

\*\*Use Green Labels for this Unit

WHEN DISASSEMBLING ALUMINUM EXTRUSION, TIGHTEN ALL SETSCREWS AND LOCKS TO PREVENT LOSS DURING SHIPPING

# visionary™ IDESIGNS

## Using Your Setup Instructions

The Visionary Designs Setup Instructions are created specifically for your configuration. They are laid out sequentially, including an exploded view of the entire display, and then a logical series of detailed steps to assemble the main structure and components. We encourage you to study the instructions **before** attempting to assemble your exhibit.

Each page reminds you to tighten the setscrews after disassembling your exhibit to prevent loss of the locks and setscrews (see below in RED). This is **VERY IMPORTANT**.

## Cleaning and Packing Your Display

- 1) Use care when cleaning aluminum extrusion or acrylic inserts. Use only non-abrasive cleaners.
- 2) When cleaning laminate inserts or countertops, use mild cleansers and a soft material such as cotton.
- 3) Keep all display components away from extreme heat and long exposure to sunlight to avoid warping and fading.
- 4) Retain all packing material. It will make re-packing much easier and will reduce the likelihood of shipping damage.



**The Tool**

Most Visionary Designs exhibits can be assembled with the supplied Hex Key Tool. Occasionally, a flat head screwdriver may be required.



**Typical Connection**

Most horizontal extrusion connections have a patented expandable lock. This lock inserts into the groove of an opposing extrusion. Tightening the lock with the Hex Key Tool expands the lock and creates a strong positive connection.



**Typical Connection (cont'd)**

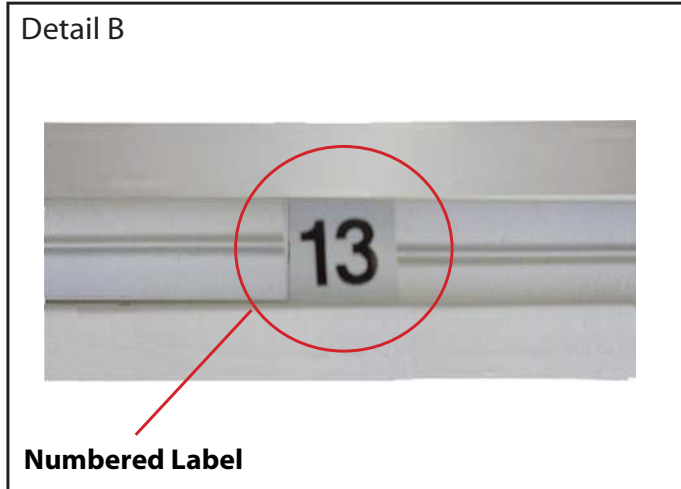

**Numbered Label**

Each extrusion contains a numbered label which corresponds with setup instructions. The label is located within a groove of the extrusion (when possible). With Visionary Designs the labels contain Black numbers unless otherwise specified.



**Horizontal Inline Connection** (remove only one setscrew)

Remove only (1) setscrew when disassembling. Replace setscrew in extrusion after assembling it. Before packing, replace setscrew in extrusion to avoid losing it.

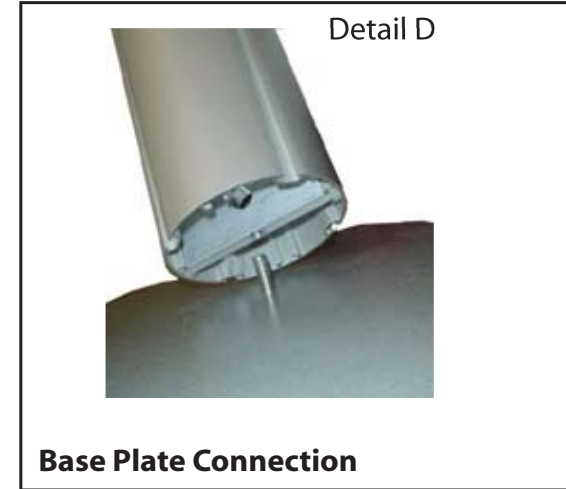

**Base Plate Connection**

Attach base plate to round or square vertical extrusion using the bolt provided. Be careful not to strip the threads.

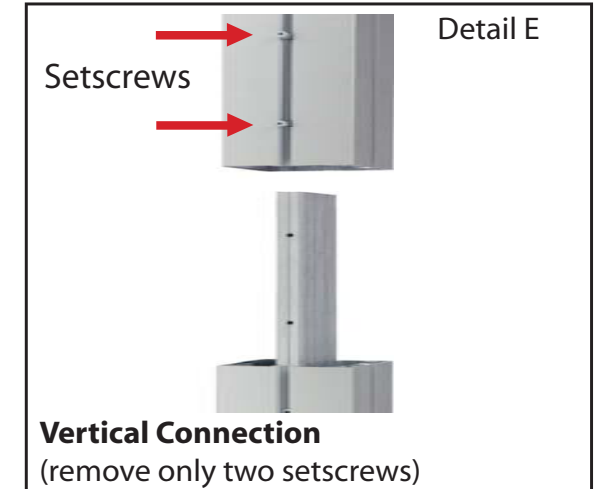

**Vertical Connection**  
(remove only two setscrews)

When vertical extrusions are packed in portable cases rather than crates or tubs, they must be broken down into smaller sections which then require assembly.

Remove only (2) setscrews when disassembling. Replace setscrews in extrusion after assembling it. Before packing, replace setscrews in extrusion to avoid losing them.

**WHEN DISASSEMBLING ALUMINUM EXTRUSION, TIGHTEN ALL SETSCREWS AND LOCKS TO PREVENT LOSS DURING SHIPPING**

Part Number	Qty	Description
1	1	95"h Vertical extrusion
2	1	95"h Vertical extrusion
3	1	95"h Vertical extrusion
4	1	95"h Vertical extrusion
4A	1	Base Plate
6	2	54"w Horizontal extrusion
6A	1	54"w Horizontal extrusion w/ holes for counter attachment <b>(HOLES MUST FACE FORWARD)</b>
7	2	54"w Horizontal extrusion w/ holes for Monitor Mount <b>(HOLES MUST FACE FORWARD)</b>
8	2	2.709"w Vertical extrusion
9	3	12.278"h Horizontal extrusion
10	2	35.5"h Horizontal extrusion
11	4	35.5"w Horizontal extrusion w/ holes for Shelf Attachment <b>(HOLES MUST FACE FORWARD)</b>

**\*\*NOTE:** Numbered side of inserts must face Backward.

- Steps**
- 1) Attach horizontal extrusion [4] to Base Plate [4A] and set aside.
  - 2) Connect horizontal extrusion [6] between vertical extrusions [1 and 2] placing insert as shown.
  - 3) Continue by attaching [6A] then insert. **NOTE: Make sure Holes FACE FORWARD**
  - 4) Attach horizontal extrusion [7] between verticals and atop insert then place vertical extrusions [8] loosely in place as shown atop horizontal extrusion [7], place smaller inserts as shown and tighten extrusions [8] into place.  
**NOTE: Make sure Holes FACE FORWARD**
  - 5) Continue attaching upper horizontal extrusions [7 and 6] between verticals [1 and 2] placing inserts as indicated.
  - 6) Connect horizontal extrusions [9] between vertical extrusions [2 and 3] placing inserts as shown.
  - 7) Connect horizontal extrusions [10 and 11] between vertical extrusions [3 and 4] placing inserts as shown.

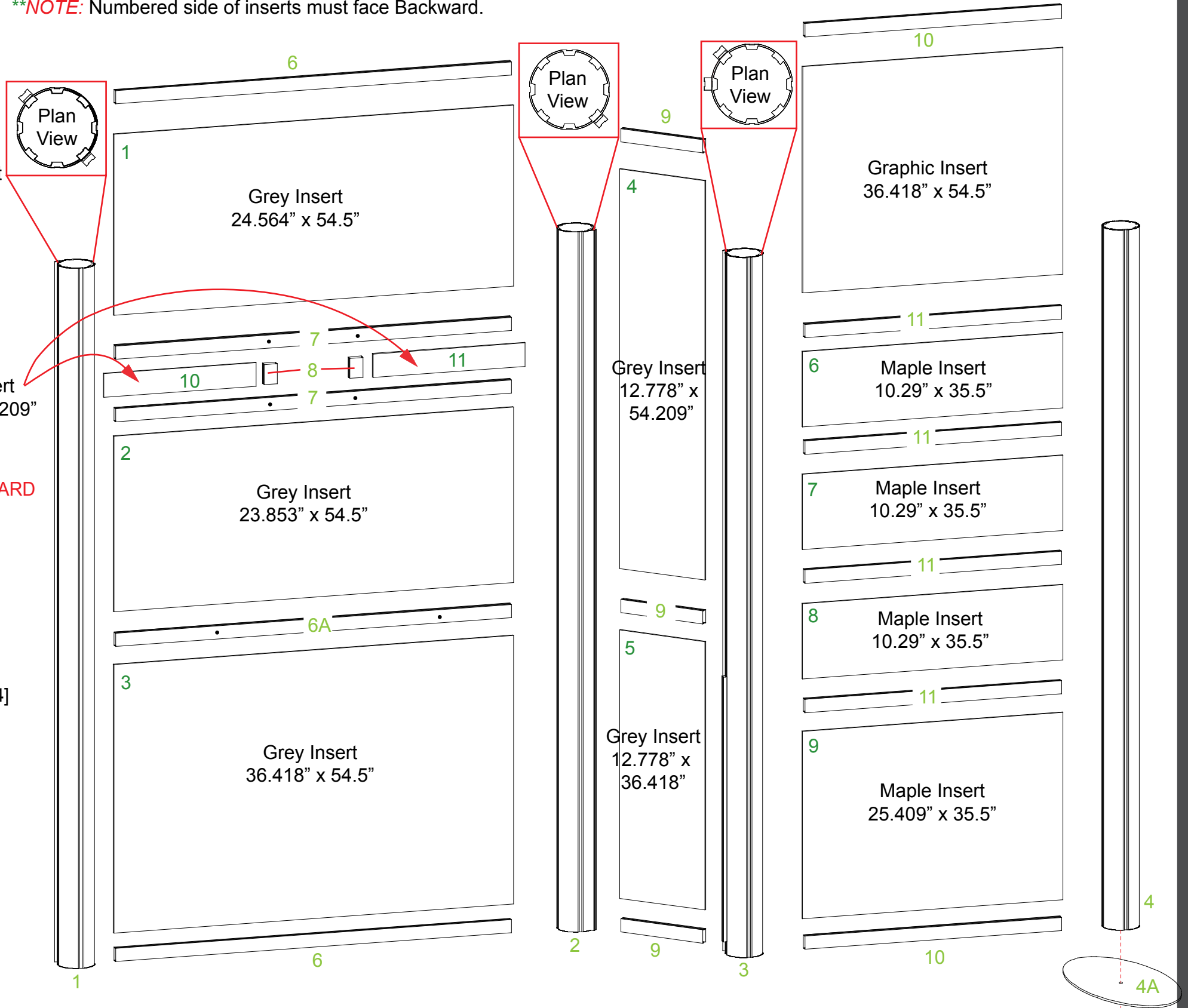

**WHEN DISASSEMBLING ALUMINUM EXTRUSION, TIGHTEN ALL SETSCREWS AND LOCKS TO PREVENT LOSS DURING SHIPPING**

866.652.2100

Part Number	Qty for Step	Description
5	1	39.5" h Vertical extrusion
12	2	8" w Horizontal extrusion
13	2	66.8427" w Horizontal extrusion
14	1	35.918" h Vertical extrusion
15	1	35.918" h Vertical extrusion

Steps

- 1) Attach horizontal extrusion [12] between vertical extrusions [1 from previous page and 5], placing insert as shown.
- 2) Attach lower horizontal extrusion [13] between vertical extrusions [5 and 3 from previous page].
- 3) Connect vertical extrusions [14 and 15] loosely to horizontal extrusion [13] then place doors as shown. Tighten vertical extrusions [14 and 15] completely in place.
- 4) Attach upper horizontal extrusion [13] between vertical extrusions 5 and 3 and atop vertical extrusions [14 and 15].
- 5) Attach shelf supports to Velcro strips located on inside of assembled base where indicated.
- 6) Set internal shelf atop shelf supports.

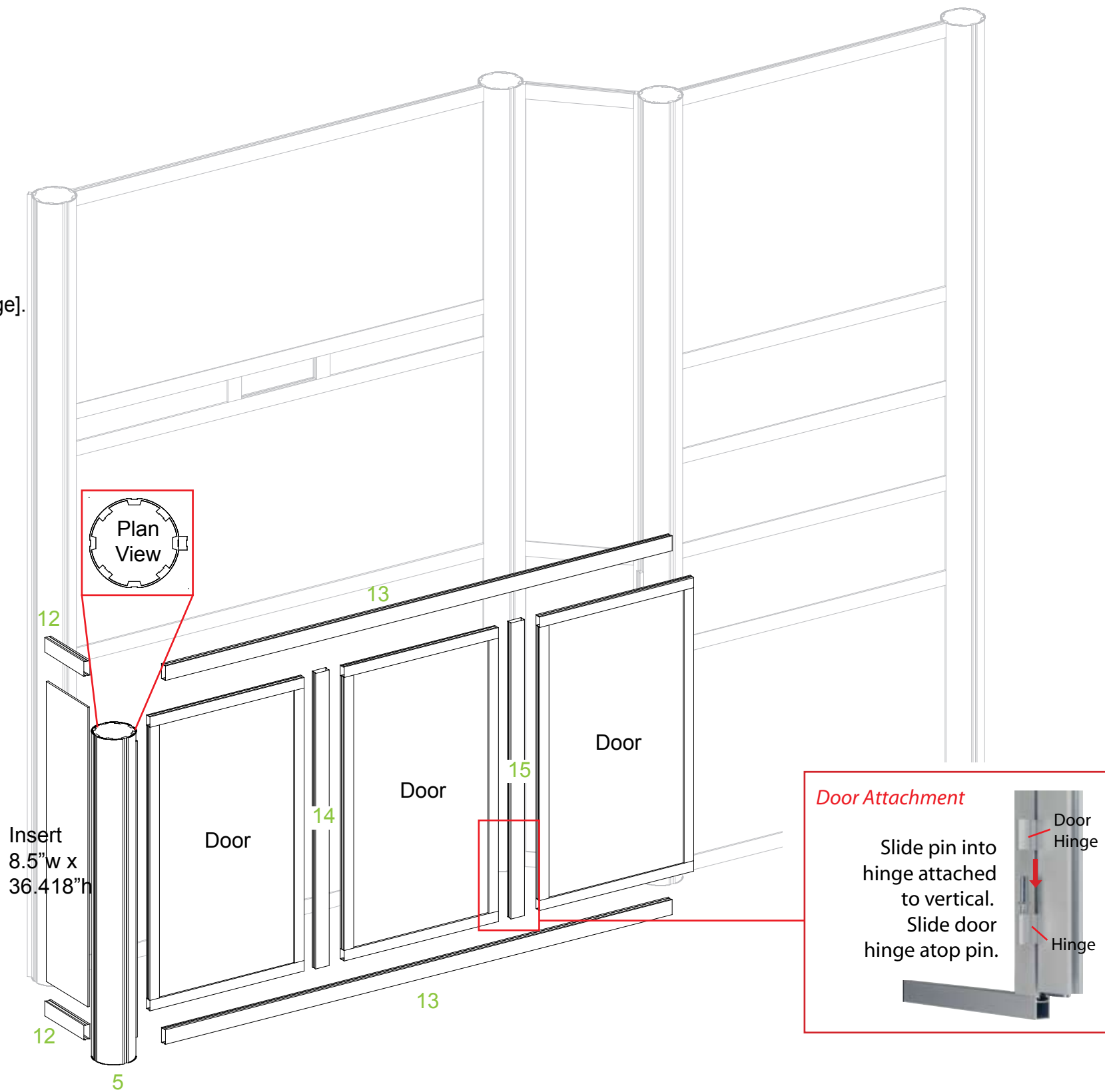
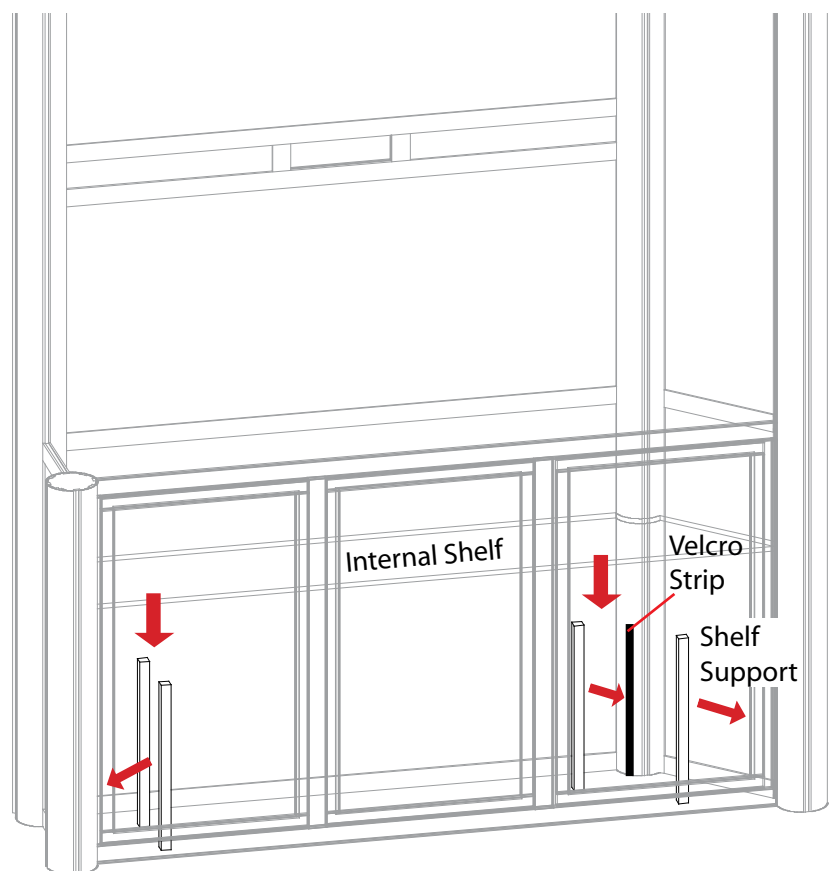

**WHEN DISASSEMBLING ALUMINUM EXTRUSION, TIGHTEN ALL SETSCREWS AND LOCKS TO PREVENT LOSS DURING SHIPPING**

866.652.2100

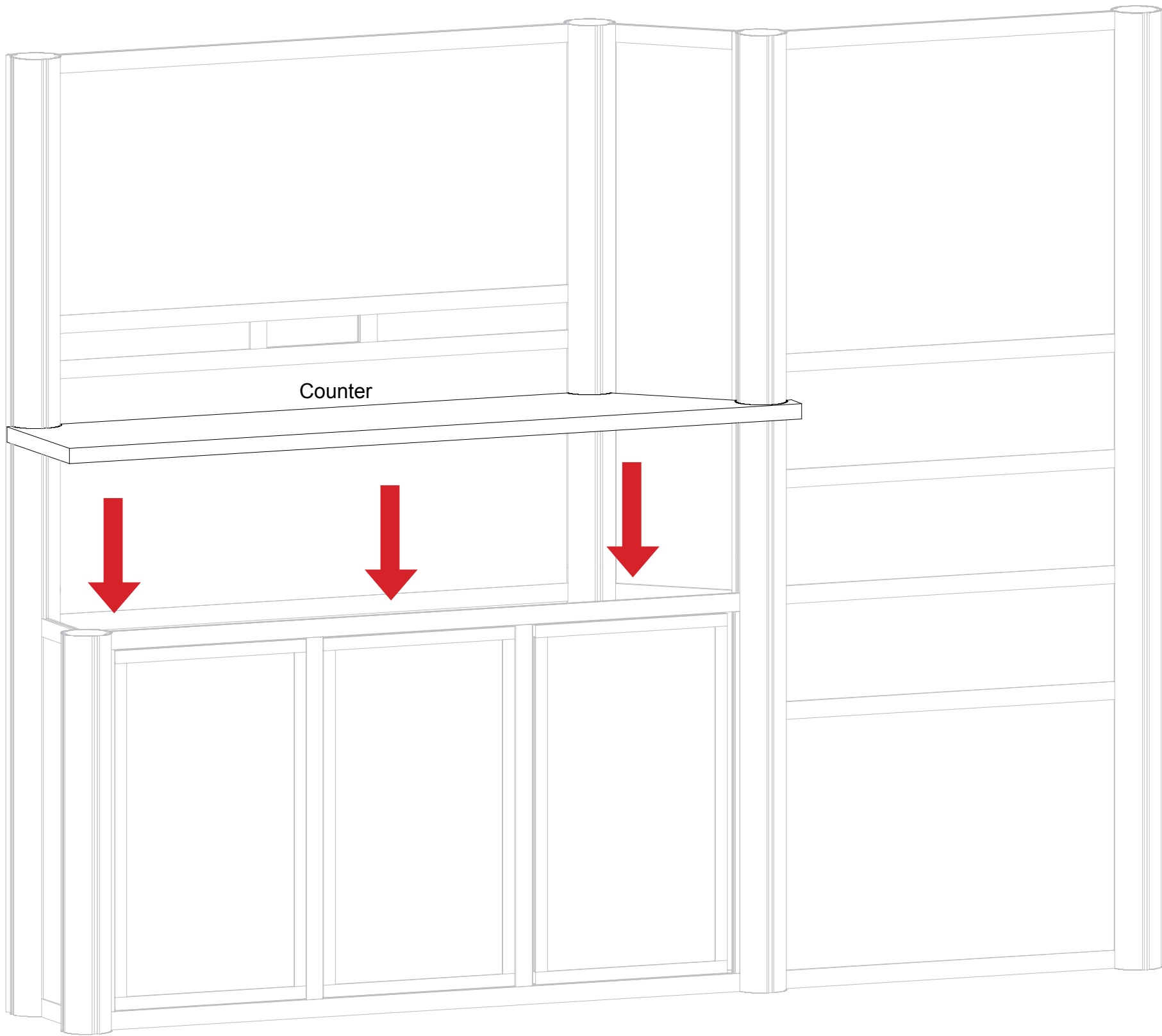

Set counter atop assembled alcove and secure to backwall metal using thumbscrews provided.

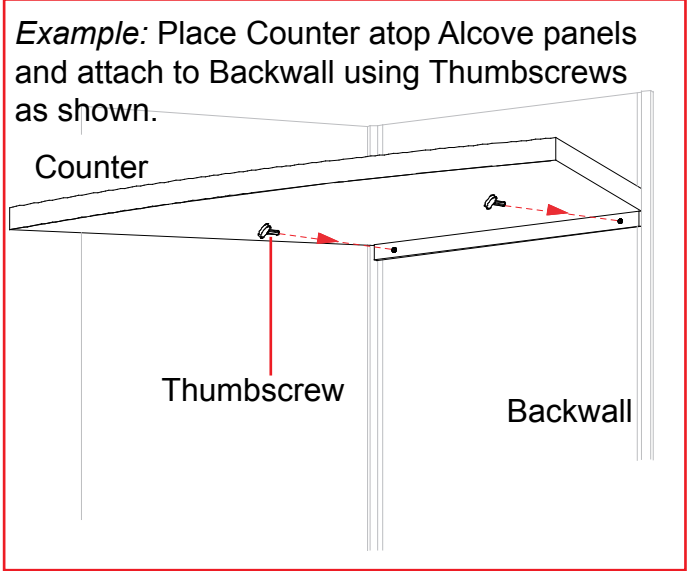

**WHEN DISASSEMBLING ALUMINUM EXTRUSION, TIGHTEN ALL SETSCREWS AND LOCKS TO PREVENT LOSS DURING SHIPPING**

866.652.2100

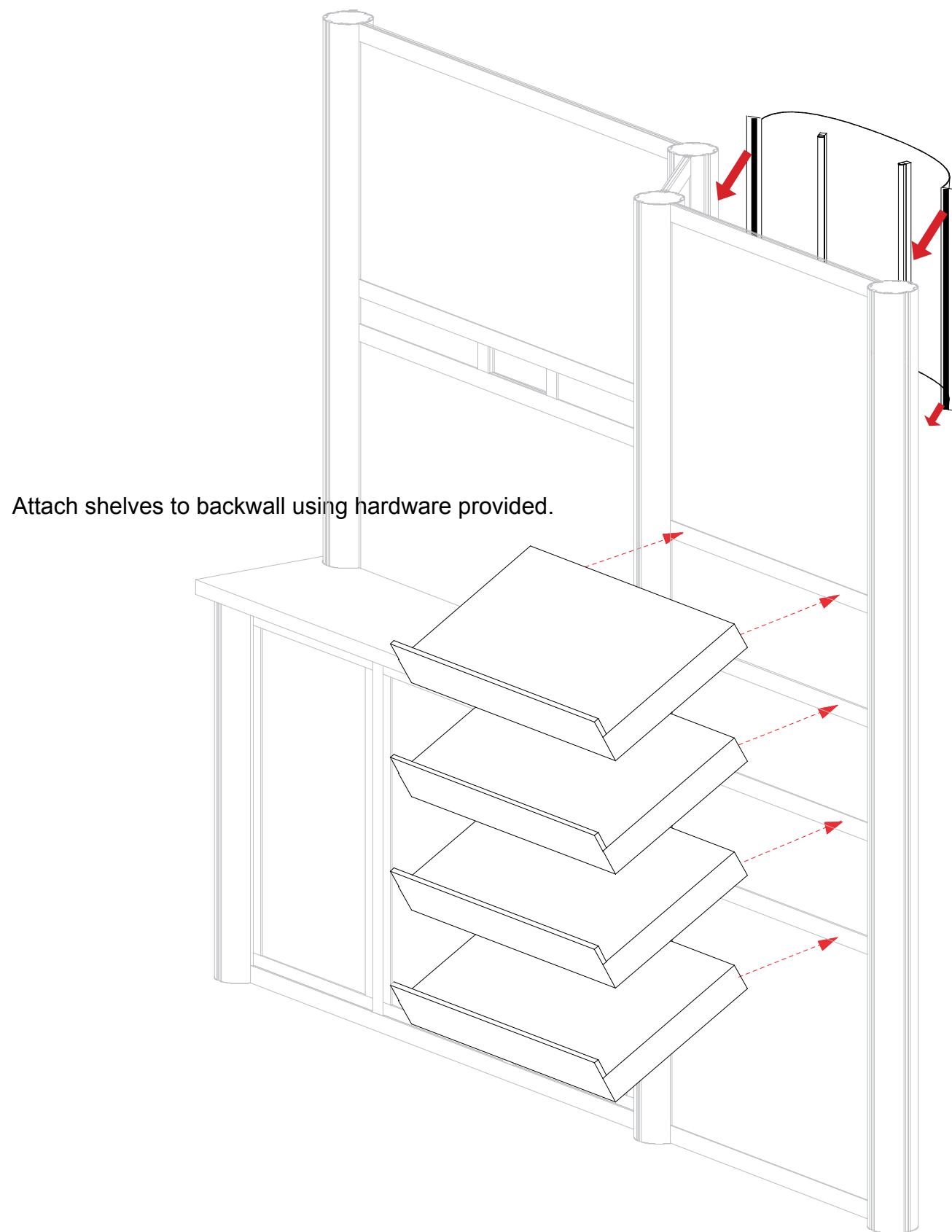

Attach Light Reflector to Velcro Strips located on Vertical Extrusions where indicated.

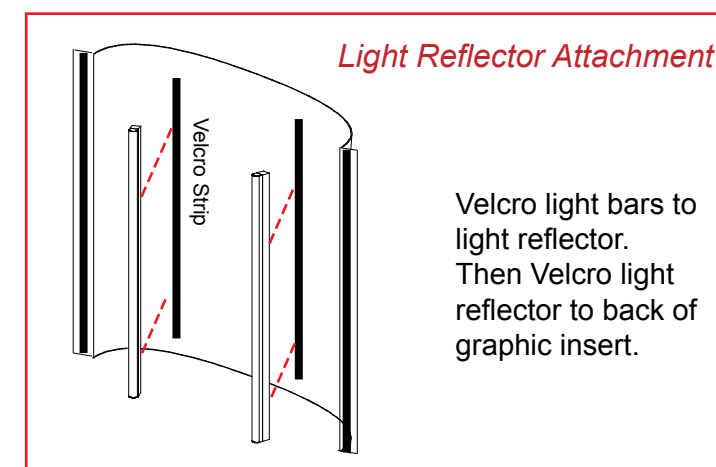

**WHEN DISASSEMBLING ALUMINUM EXTRUSION, TIGHTEN ALL SETSCREWS AND LOCKS TO PREVENT LOSS DURING SHIPPING**



866.652.2100

**Using Your Setup Instructions**

The Aero Overhead Sign Setup Instructions are created specifically for your configuration. They include an exploded view of the frame which is sequentially numbered. We encourage you to study the instructions before attempting to assemble your exhibit.

Connections are kept very simple: no tools. Everything assembles with push-button connectors and pre-connected horizontal sections.

**Cleaning and Packing Your Display**

- 1) Use care when cleaning aluminum extrusion or acrylic inserts. Use only non-abrasive cleaners.
- 2) Retain all packing material. It will make re-packing much easier and will reduce the likelihood of shipping damage.

**Steps:**

- 1) Connect canopy pieces together as shown.
- 2) Apply pillow case graphic to assembled canopy.
- 3) Place atop assembled backwall.

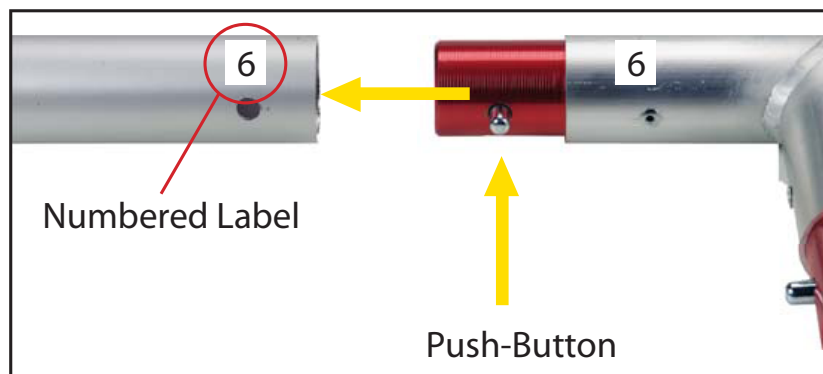
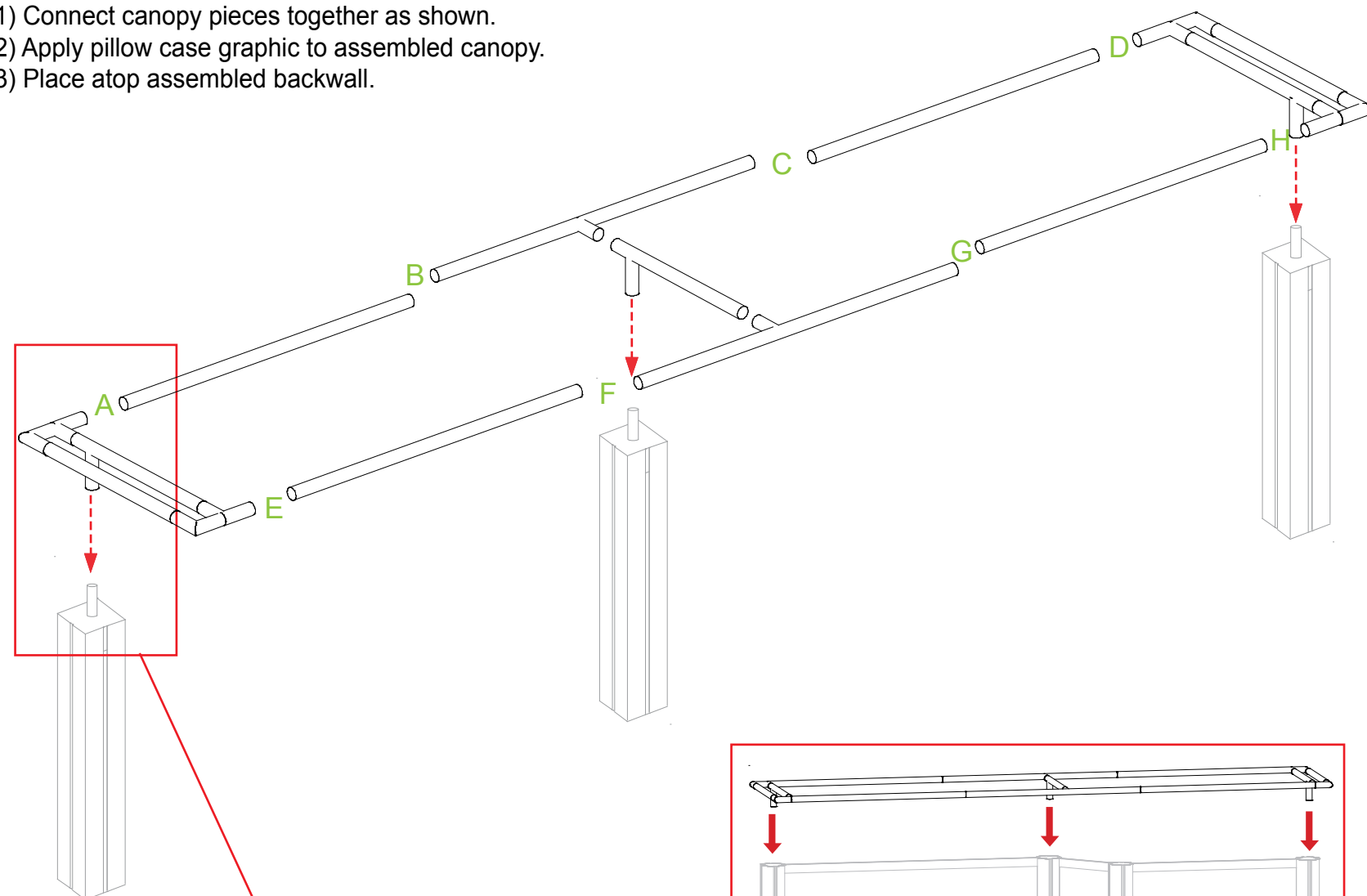

Connections are made by holding the button down and sliding the red tube into opposing tube until the connection is made. To disassemble push button and pull or twist extrusions apart.

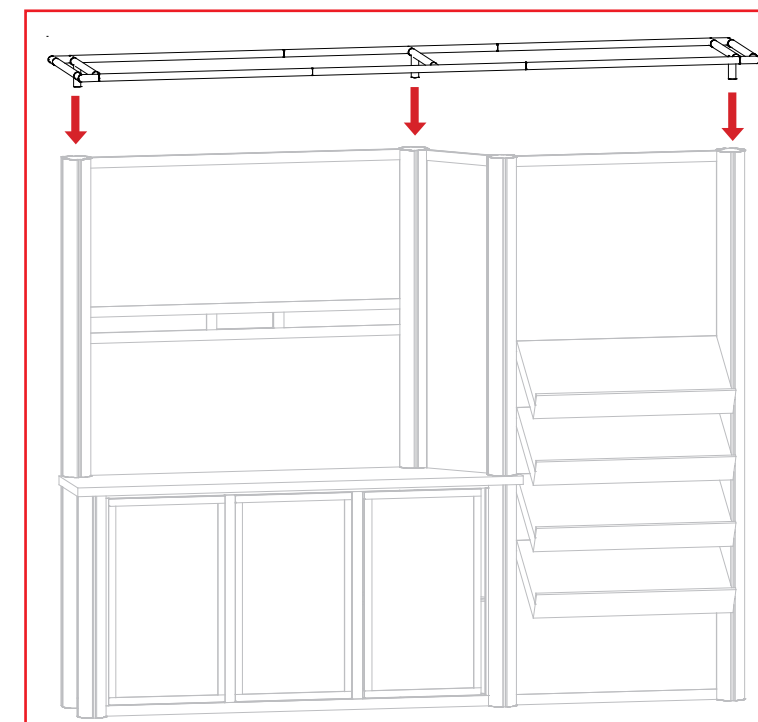
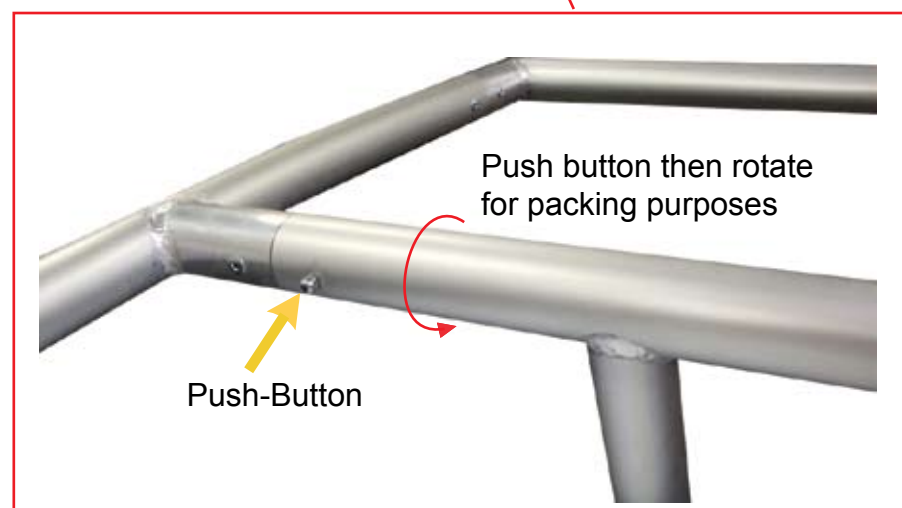
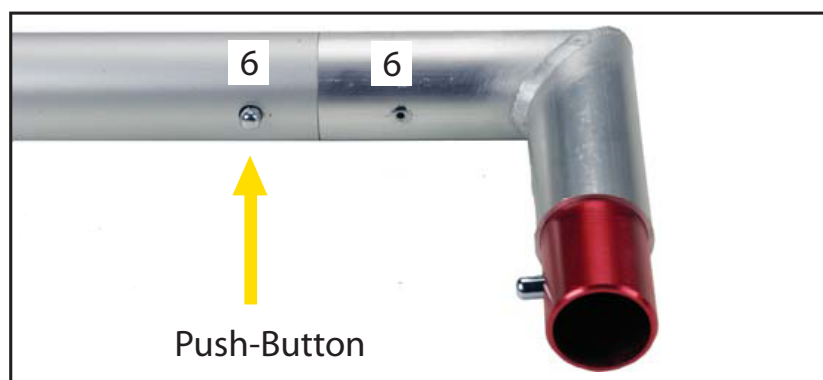

**WHEN DISASSEMBLING ALUMINUM EXTRUSION, TIGHTEN ALL SETSCREWS AND LOCKS TO PREVENT LOSS DURING SHIPPING**

866.652.2100

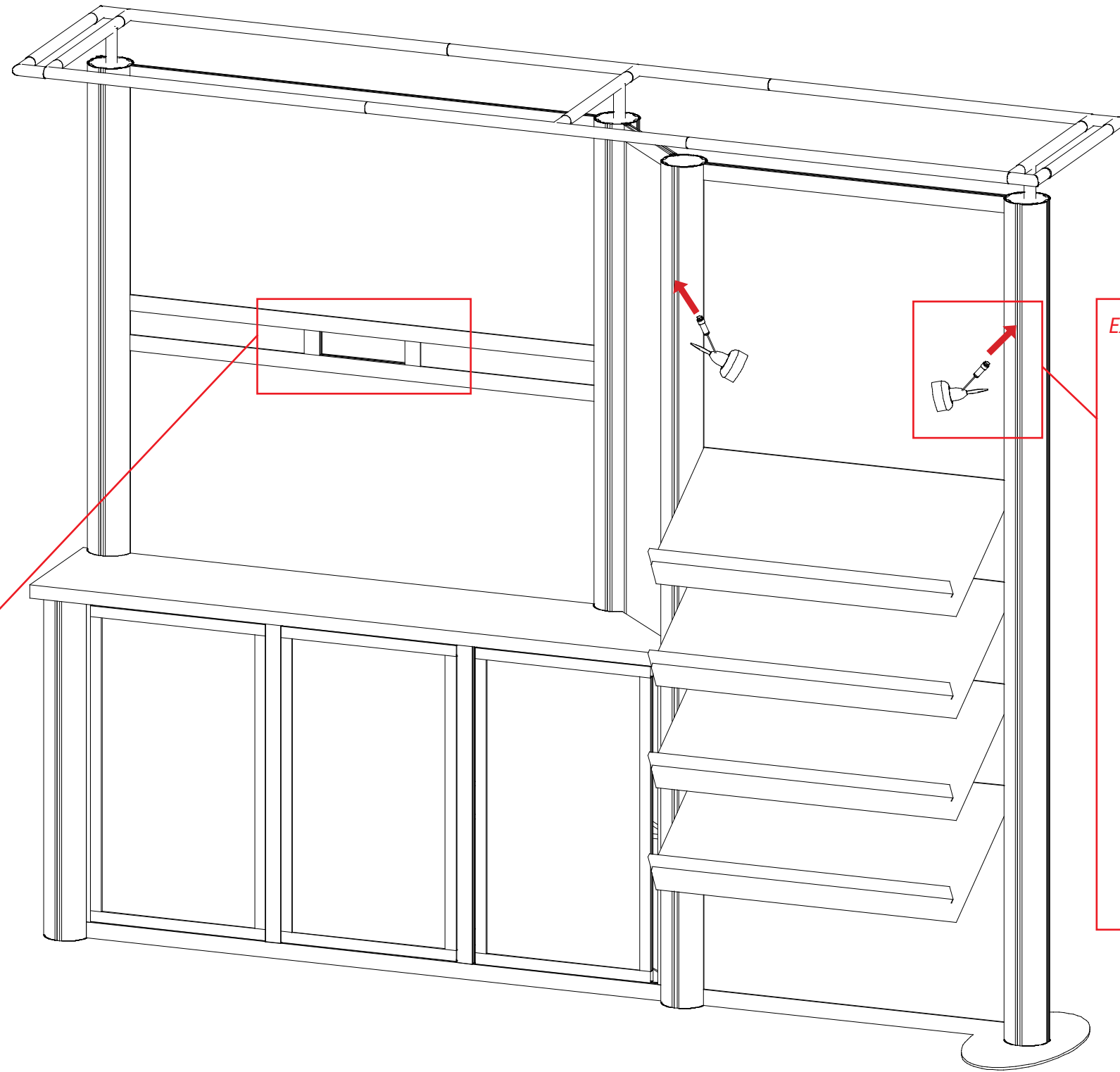

Attach monitor brackets to back of monitor.

Hook monitor brackets over top of wall plate, then secure with safety bolts to bottom of monitor brackets.

Attach wall plate to vertical extrusion using supplied bolts and wing nuts.

Modul Extrusion

Panel

*Example of Rail Light Attachment*

1. insert

2. press and twist 90°

Slide fixed clip into groove of extrusion [2].

locking nut

Tighten locking nut to secure light in place

**WHEN DISASSEMBLING ALUMINUM EXTRUSION, TIGHTEN ALL SETSCREWS AND LOCKS TO PREVENT LOSS DURING SHIPPING**

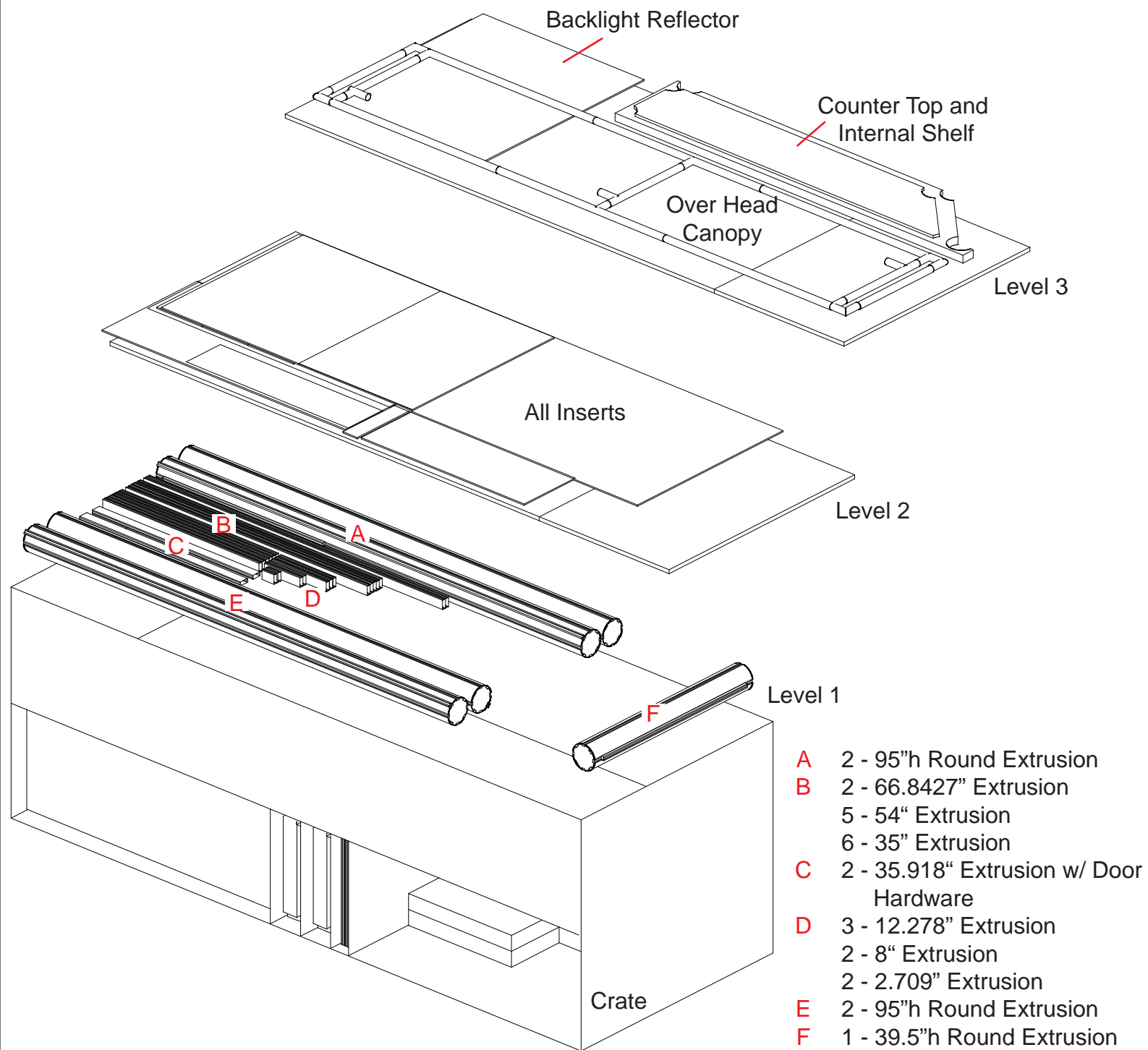

Level 3



Level 2



Level 1



Top Level

WHEN DISASSEMBLING ALUMINUM EXTRUSION, TIGHTEN ALL SETSCREWS AND LOCKS TO PREVENT LOSS DURING SHIPPING



Fron View of Crate

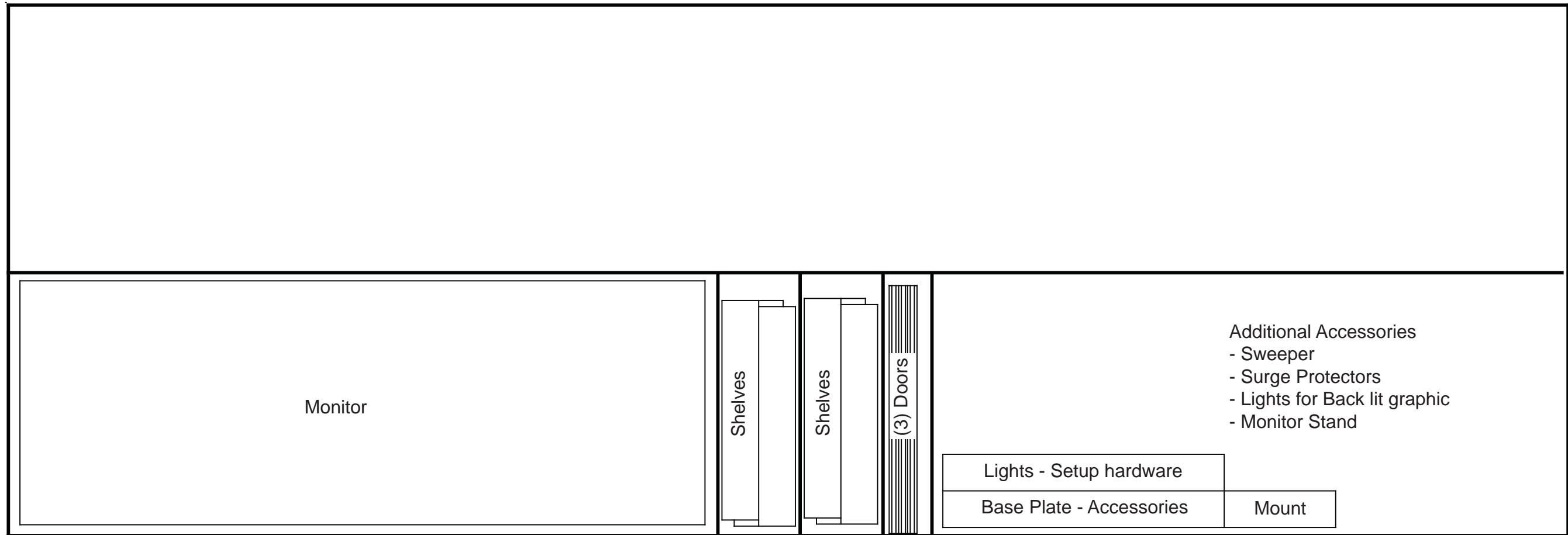

**WHEN DISASSEMBLING ALUMINUM EXTRUSION, TIGHTEN ALL SETSCREWS AND LOCKS TO PREVENT LOSS DURING SHIPPING**



Front View - Counter Ships Assembled

**WHEN DISASSEMBLING ALUMINUM EXTRUSION, TIGHTEN ALL SETSCREWS AND LOCKS TO PREVENT LOSS DURING SHIPPING**