

# euro It | HYBRIDS

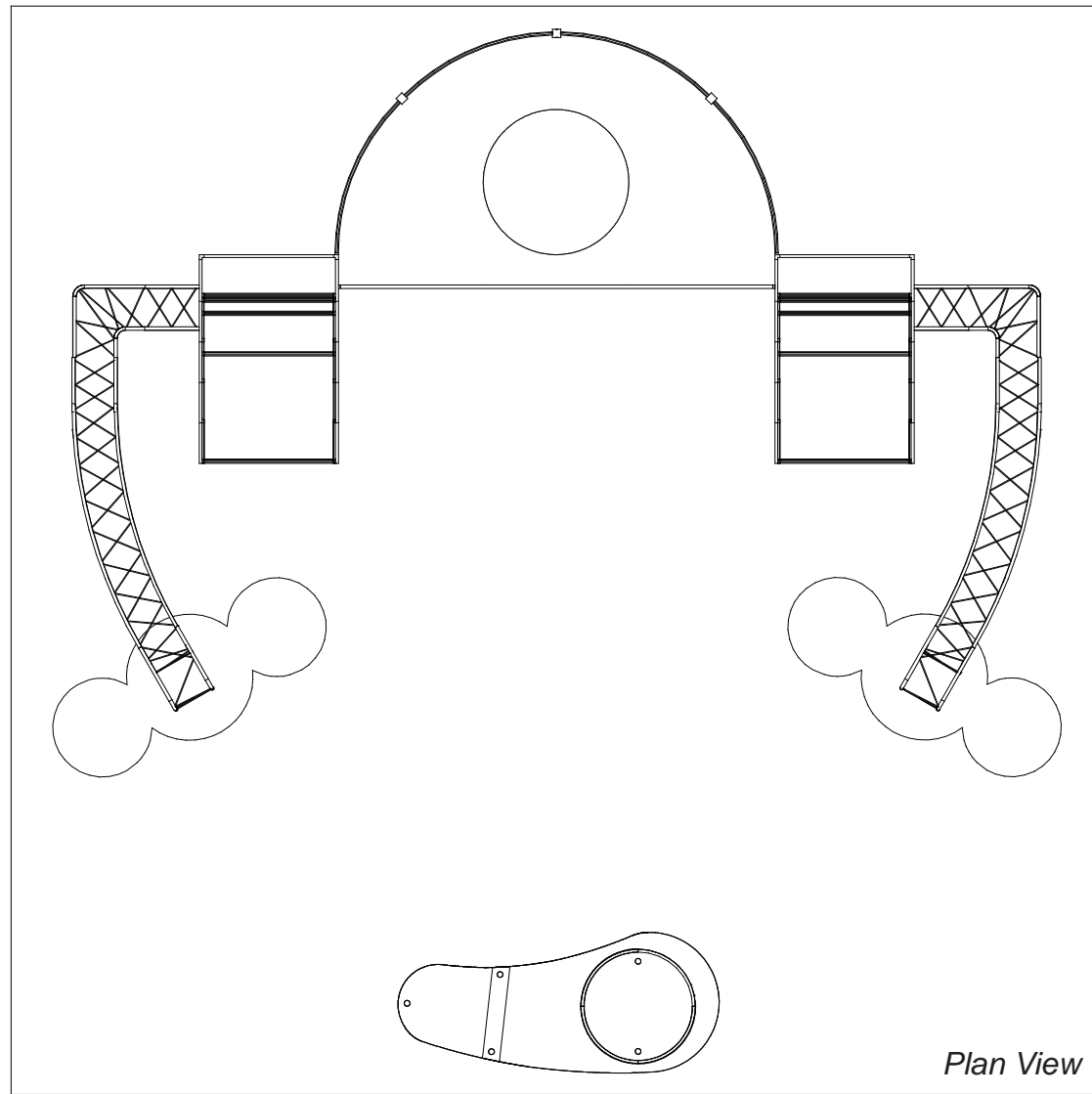

20'

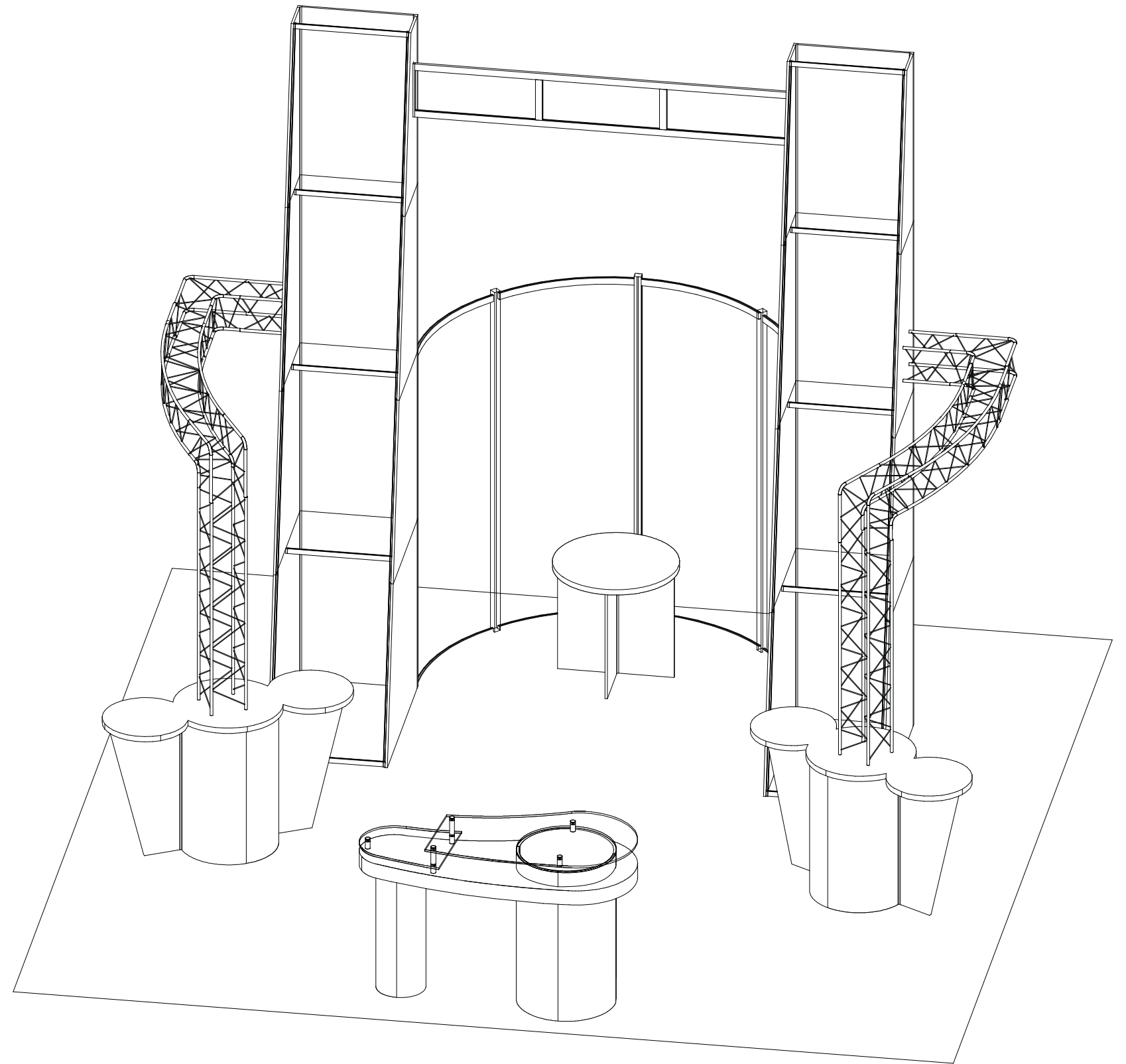

WHEN DISASSEMBLING ALUMINUM EXTRUSION, TIGHTEN ALL SETSCREWS AND LOCKS TO PREVENT LOSS DURING SHIPPING

# euro lt | HYBRIDS

## Using Your Setup Instructions

The Euro LT Hybrids Setup Instructions are created specifically for your configuration. They are laid out sequentially in levels, including exploded views, and a logical series of detailed steps to assemble the main structure and components. We encourage you to study the instructions **before** attempting to assemble your exhibit.

Each page reminds you to tighten the setscrews after disassembling your exhibit to prevent loss of the locks and setscrews (see below in RED). This is VERY IMPORTANT.

## Cleaning and Packing Your Display

- 1) Use care when cleaning aluminum extrusion or acrylic inserts. Use only non-abrasive cleaners.
- 2) When cleaning laminate inserts, countertops, or panels use mild cleansers and a soft material such as cotton.
- 3) Keep all display components away from extreme heat and long exposure to sunlight to avoid warping and fading.
- 4) Retain all packing material. It will make re-packing much easier and will reduce the likelihood of shipping damage.

## General Setup Instructions for Extrusion System



Most exhibits can be assembled with the supplied Hex Key Tool. Occasionally, a flat head screwdriver may be required.



Most horizontal extrusion connections have a patented expandable lock. This lock inserts into the groove of an opposing extrusion. Tightening the lock with the Hex Key Tool expands the lock and creates a strong positive connection.

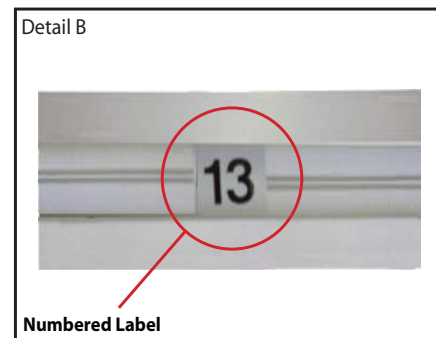

Each extrusion contains a numbered label which corresponds with setup instructions. The label is located within a groove of the extrusion (when possible). With extrusion components the labels contain Black numbers unless otherwise specified.



Remove only (1) setscrew when disassembling. Replace setscrew in extrusion after assembling it. Before packing, replace setscrew in extrusion to avoid losing it.

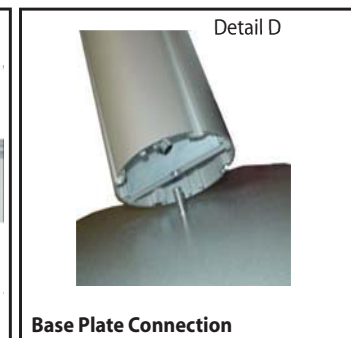

Attach base plate to round or square vertical extrusion using the bolt provided. Be careful not to strip the threads.

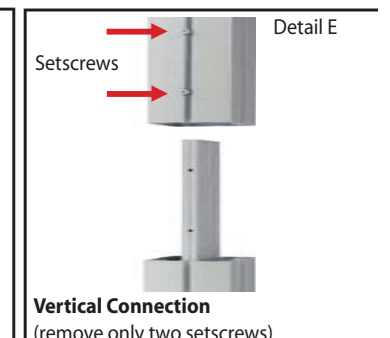

When vertical extrusions are packed in portable cases rather than crates or tubs, they must be broken down into smaller section which then require assembly.

Remove only (2) setscrews when disassembling. Replace setscrews in extrusion after assembling it. Before packing, replace setscrews in extrusion to avoid losing them.

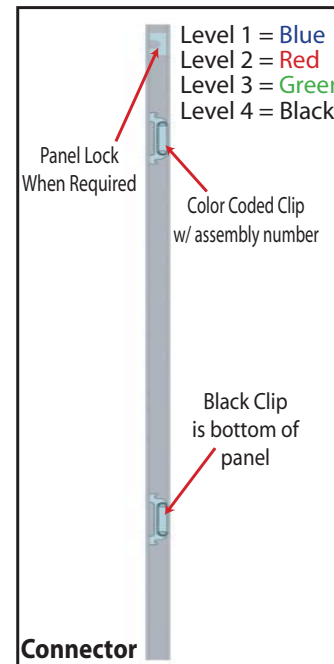

Each component has 2 clips, the lower clip is ALWAYS black. The top clip is color coded to distinguish which level. The color coded clip also contains the numbered label.

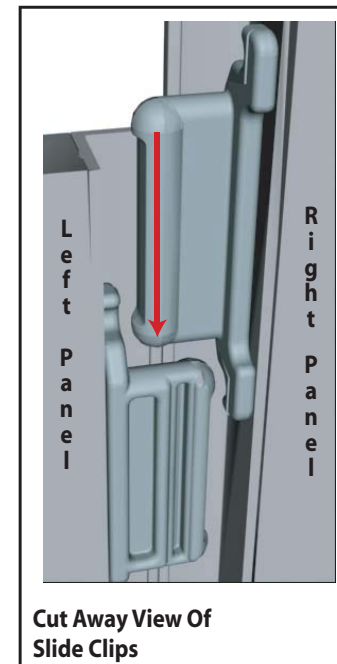

Components connect together by aligning them and sliding downward connecting clips together.

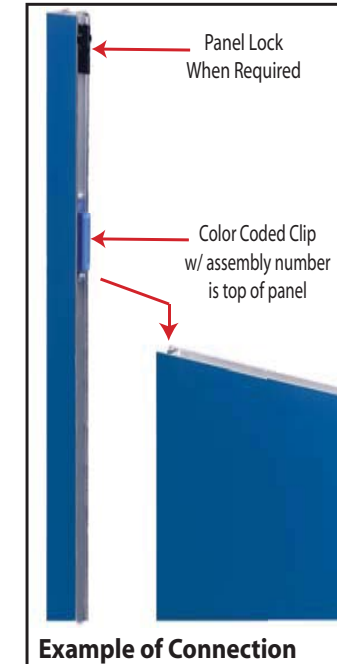

Configurations are assembled from left to right, usually starting with #1 and following the numbered sequence.

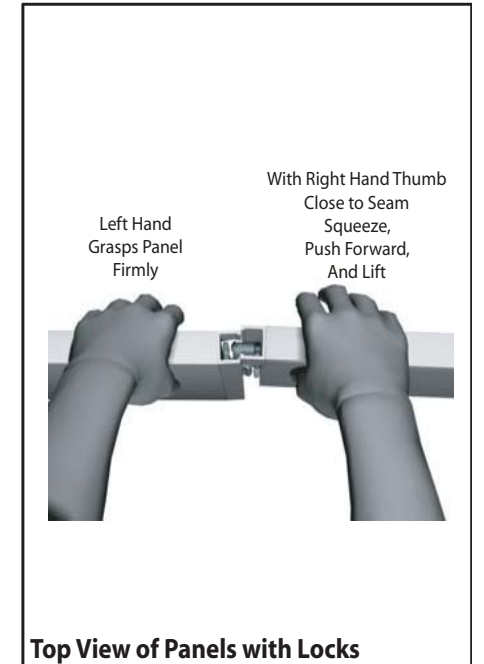

The first level of components contain panel locks that are located at the top of the panel for extra stability and seamless connection. When disassembling panels twist top connection slightly and lift right panel upward.

**WHEN DISASSEMBLING ALUMINUM EXTRUSION, TIGHTEN ALL SETSCREWS AND LOCKS TO PREVENT LOSS DURING SHIPPING**

**EURO LT System: Part List**

Item Number	Description
1	45"w x 47.5"h Flat Tapered w/ Connectors Attached
2	47.5"h 90° Connector
3	28.5"w x 47.5"h Flat Panel w/ Door
4	47.5"h 90° Connector
5	45"w x 47.5"h Tapered Panel w/ Connectors Attached
6	45"w x 47.5"h Tapered Panel w/ Connectors Attached
7	47.5"h 90° Connector
8	28.5"w x 47.5"h Flat Panel w/ Door
9	47.5"h 90° Connector
10	45"w x 47.5"h Flat Tapered w/ Connectors Attached

**Steps:**

- 1) Assemble by starting at panel #1\* and continue in numerical order.
- 2) Attach horizontal extrusions [1 and 2] between connectors located inside of panel structure as indicated.

**Modul Extrusion System: Part List**

Item	Qty.	Description
1	2	28.46"w Horizontal Extrusion
2	2	28.46"w Horizontal Extrusion w/ Steel Tape Attached

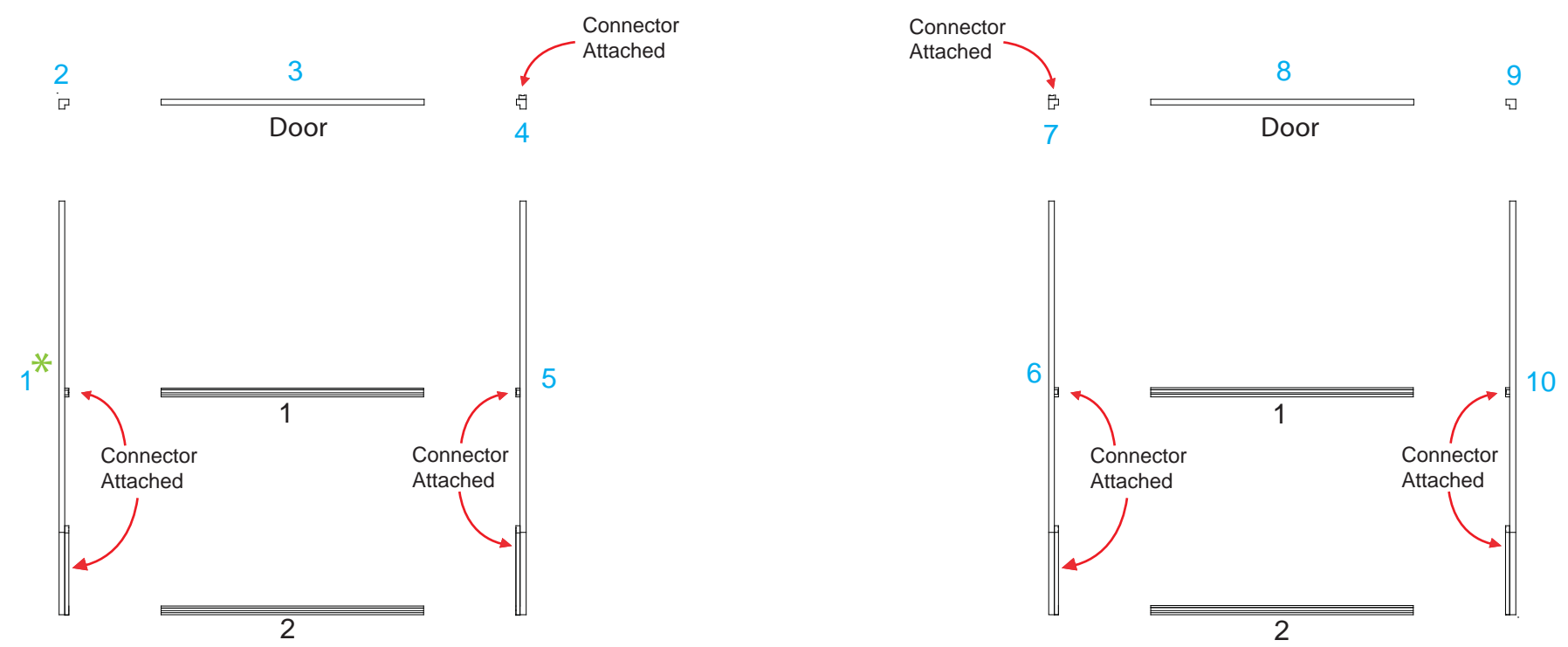
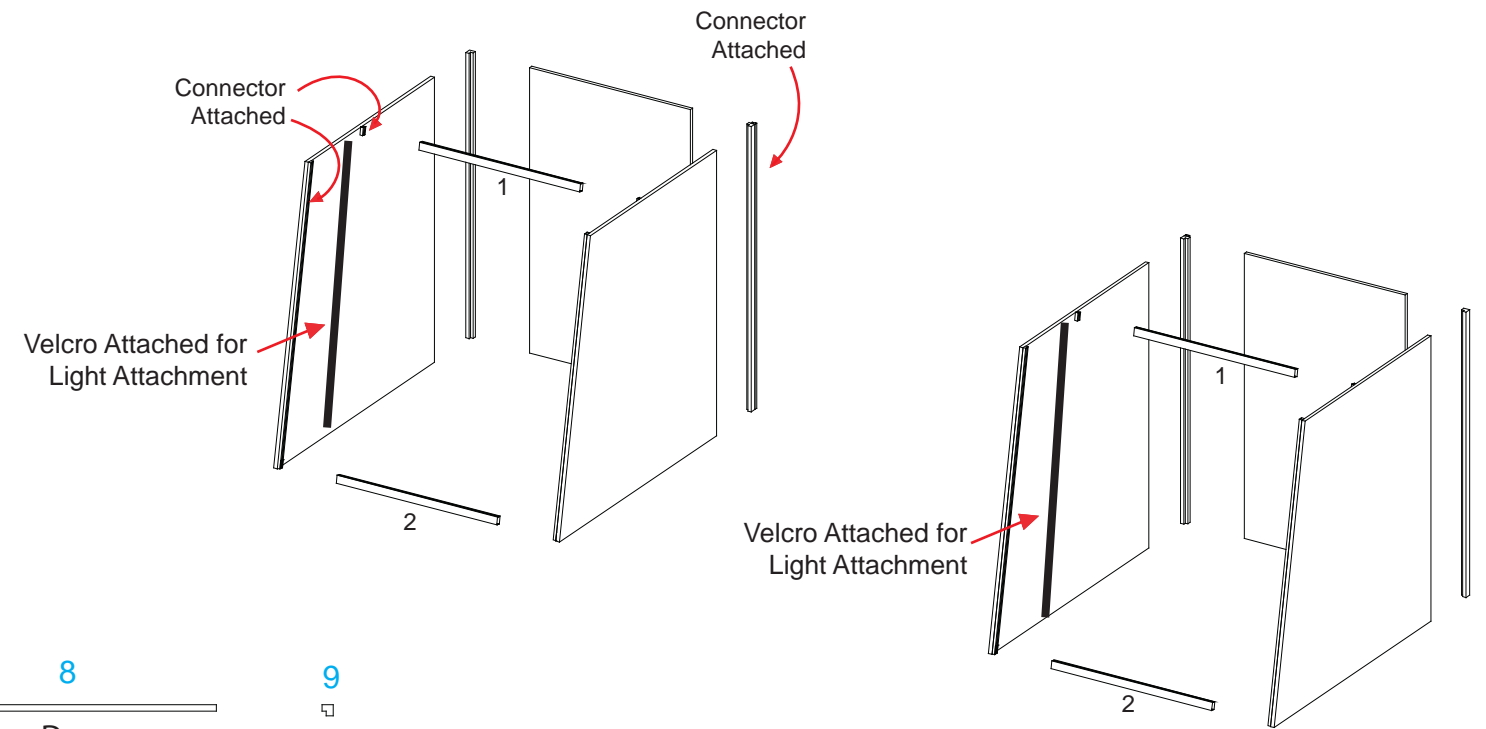

**WHEN DISASSEMBLING ALUMINUM EXTRUSION, TIGHTEN ALL SETSCREWS AND LOCKS TO PREVENT LOSS DURING SHIPPING**

**EURO LT System: Part List**

Item Number	Description
1	36" w x 47.5" h Tapered Panel w/ Connectors Attached
2	47.5" h 90° Connector
3	28.5" w x 47.5" h Flat Panel
4	47.5" h 90° Connector
5	36" w x 47.5" h Tapered Panel w/ Connectors Attached
6	36" w x 47.5" h Tapered Panel w/ Connectors Attached
7	47.5" h 90° Connector
8	28.5" w x 47.5" h Flat Panel
9	47.5" h 90° Connector
10	36" w x 47.5" h Tapered Panel w/ Connectors Attached

**Steps:**

- 1) Assemble by starting at panel #1\* and continue in numerical order.
- 2) Attach horizontal extrusions [1] between connectors located inside of panel structure as indicated.

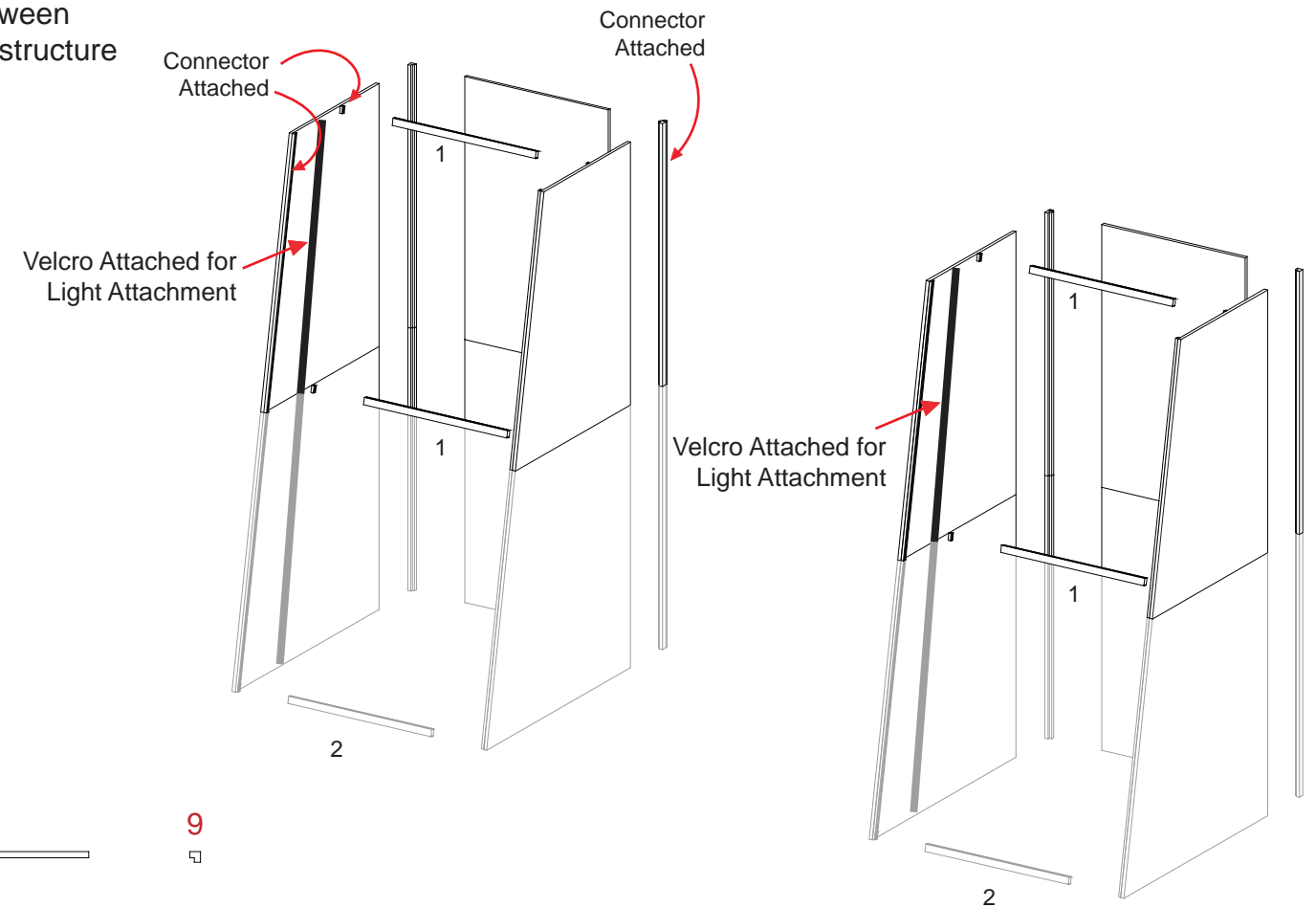

**Modul Extrusion System: Part List**

Item	Qty.	Description
1	2	28.46" w Horizontal Extrusion

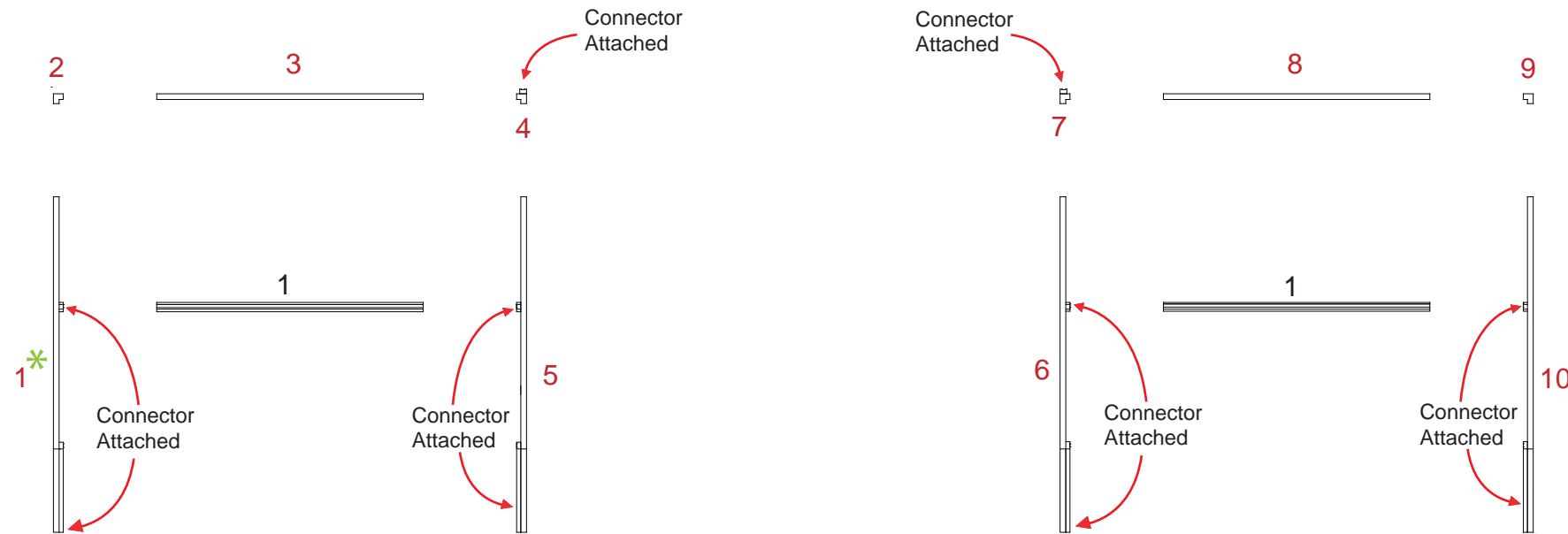

**WHEN DISASSEMBLING ALUMINUM EXTRUSION, TIGHTEN ALL SETSCREWS AND LOCKS TO PREVENT LOSS DURING SHIPPING**

866.652.2100

**EURO LT System: Part List**

Item Number	Description
1	27"w x 47.5"h Tapered Panel w/ Connectors Attached
2	47.5"h 90° Connector
3	28.5"w x 47.5"h Flat Panel
4	47.5"h 90° Connector
5	27"w x 47.5"h Tapered Panel w/ Connectors Attached
6	27"w x 47.5"h Tapered Panel w/ Connectors Attached
7	47.5"h 90° Connector
8	28.5"w x 47.5"h Flat Panel
9	47.5"h 90° Connector
10	27"w x 47.5"h Tapered Panel w/ Connectors Attached

**Steps:**

- 1) Assemble by starting at panel #1\* and continue in numerical order.
- 2) Attach horizontal extrusions [1] between connectors located inside of panel structure as indicated.

**Modul Extrusion System: Part List**

Item	Qty.	Description
1	2	28.46"w Horizontal Extrusion

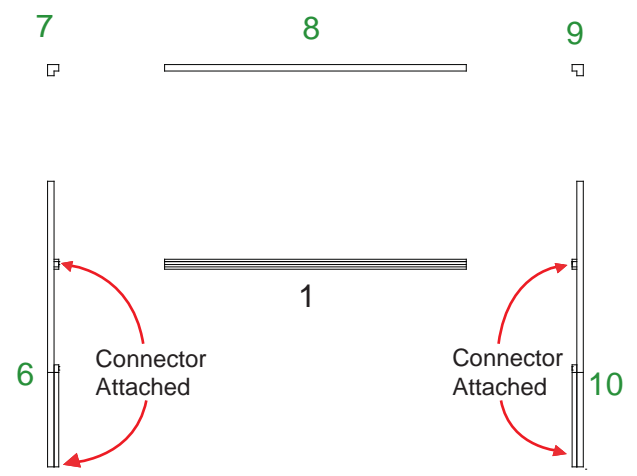
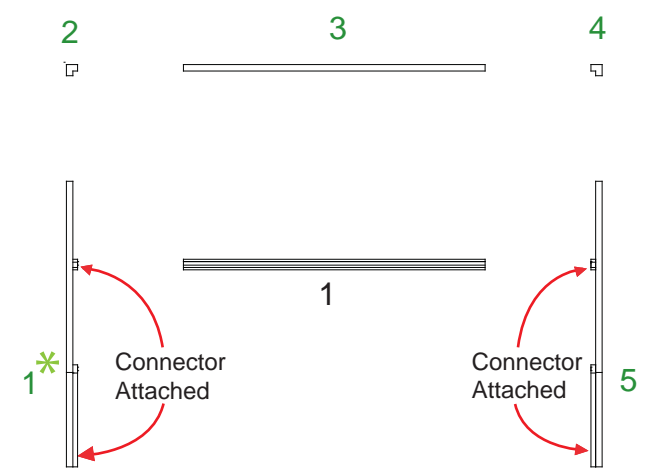
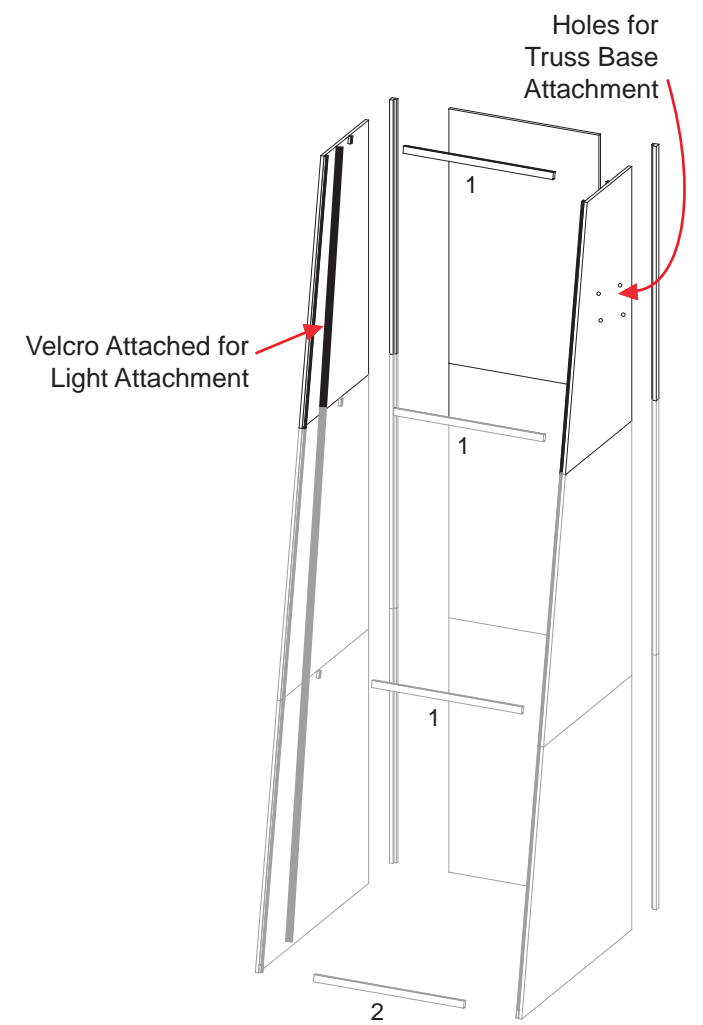
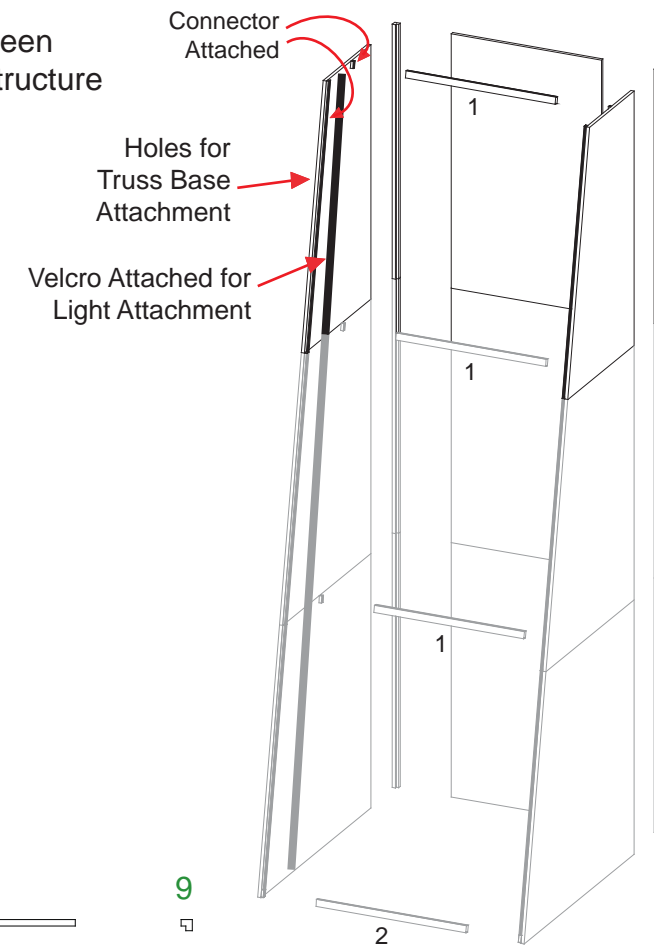

**WHEN DISASSEMBLING ALUMINUM EXTRUSION, TIGHTEN ALL SETSCREWS AND LOCKS TO PREVENT LOSS DURING SHIPPING**

**EURO LT System: Part List**

Item Number	Description
1	18.136" w x 47.5" h Flat Panel w/ Connectors Attached
2	47.5" h 90° Connector
3	28.5" w x 47.5" h Flat Panel
4	47.5" h 90° Connector
5	18.136" w x 47.5" h Flat Panel w/ Connectors Attached
6	18.136" w x 47.5" h Flat Panel w/ Connectors Attached
7	47.5" h 90° Connector
8	28.5" w x 47.5" h Flat Panel
9	47.5" h 90° Connector
10	18.136" w x 47.5" h Flat Panel w/ Connectors Attached

**Steps:**

- 1) Assemble by starting at panel #1\* and continue in numerical order.
- 2) Attach horizontal extrusions [3] between connectors located inside of panel structure as indicated.

**Modul Extrusion System: Part List**

Item	Qty.	Description
3	2	28.46" w Horizontal Extrusion

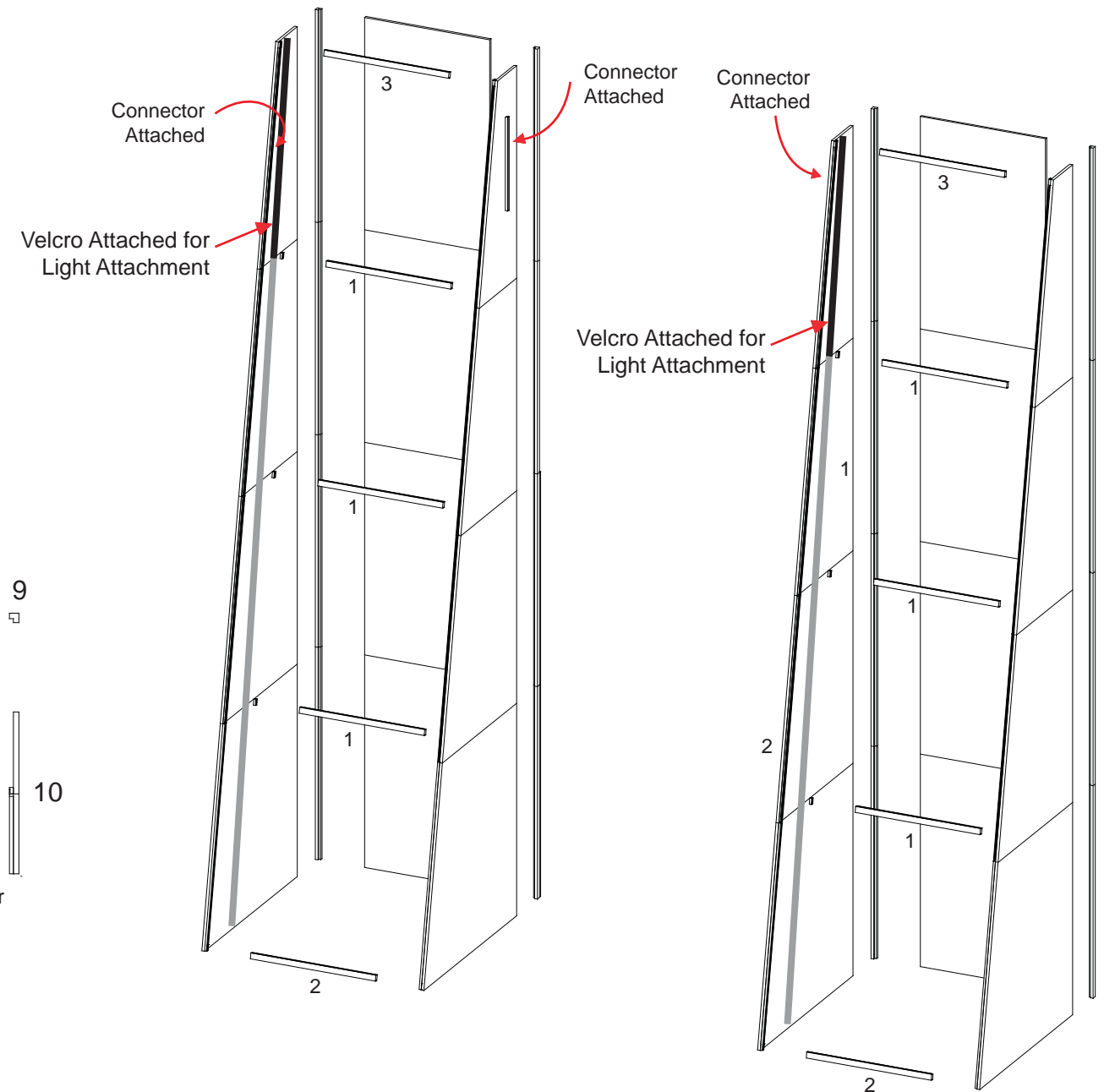
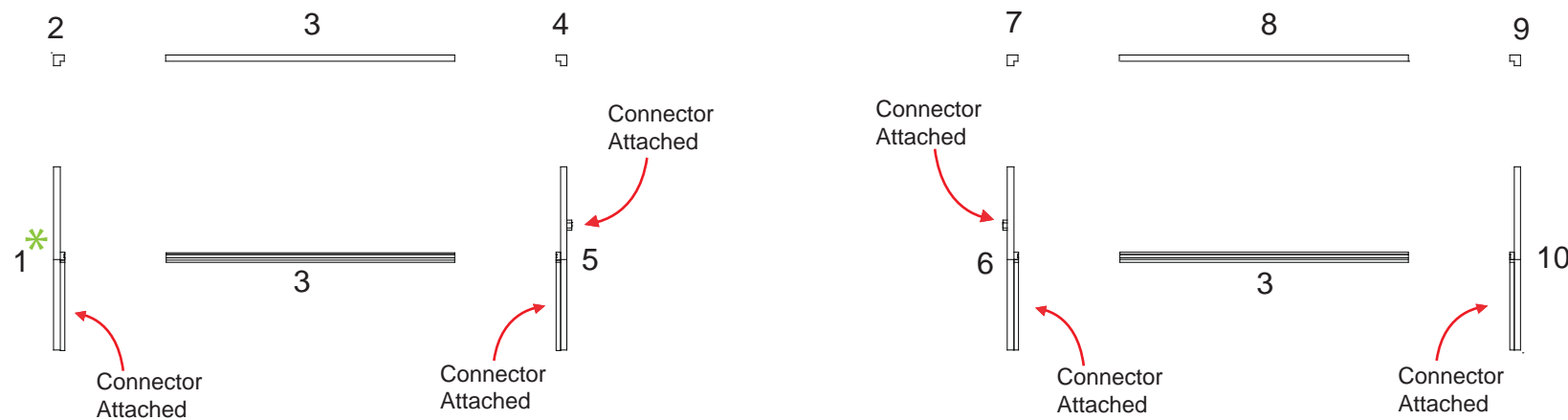

**WHEN DISASSEMBLING ALUMINUM EXTRUSION, TIGHTEN ALL SETSCREWS AND LOCKS TO PREVENT LOSS DURING SHIPPING**

Steps:

- 1) Velcro fluorescent lights to Velcro Strips located on inside of towers as shown.
- 2) Apply graphic to assembled towers by starting from bottom to top.

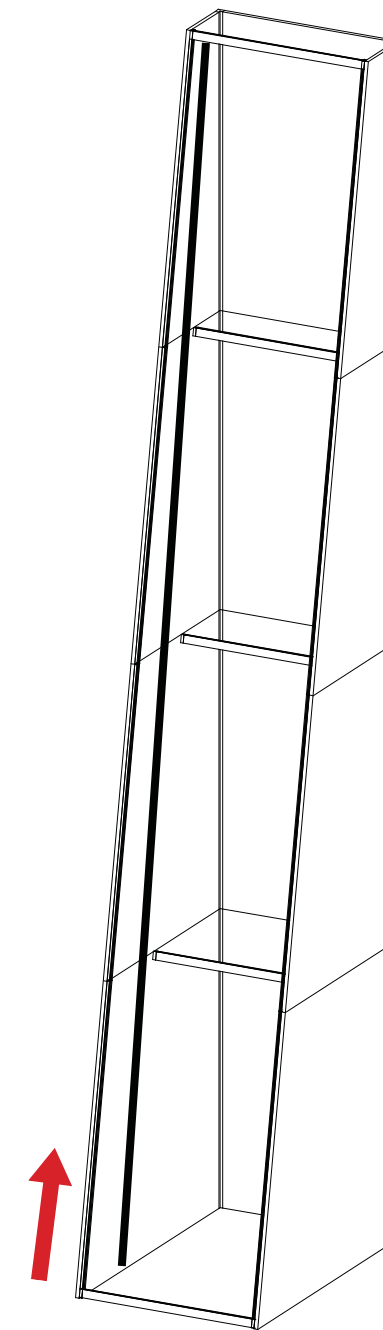
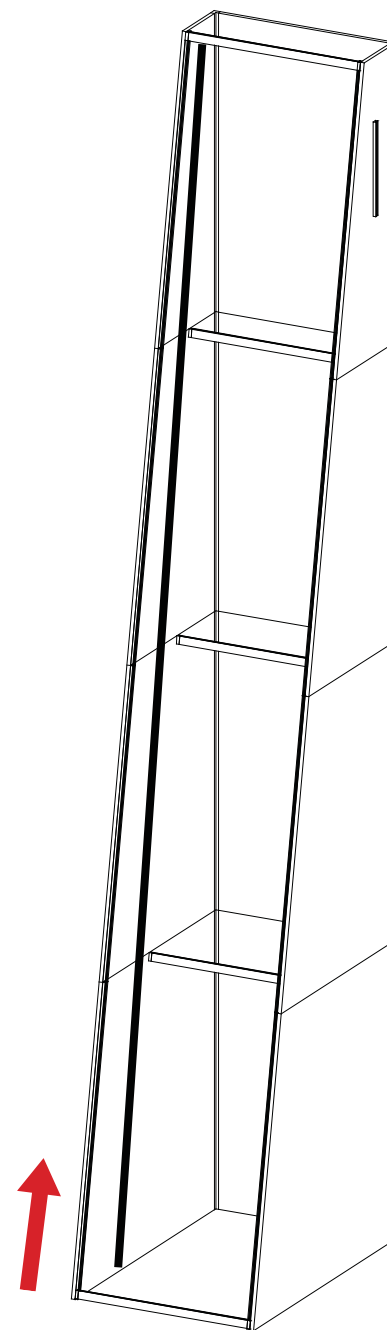
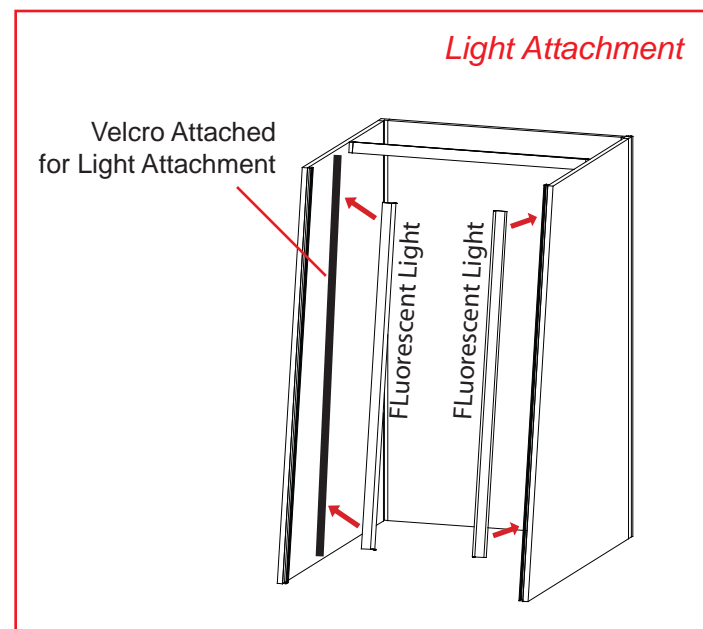

**Note:**  
Apply graphic by starting from Bottom and roll up to Top.

WHEN DISASSEMBLING ALUMINUM EXTRUSION, TIGHTEN ALL SETSCREWS AND LOCKS TO PREVENT LOSS DURING SHIPPING

866.652.2100

Item	Qty.	Description
4	3	95"h Square Extrusion
5	2	37.3811" Curved Horizontal Extrusion w/ Velcro Attached
6	2	37.3811" Curved Horizontal Extrusion w/ Velcro Attached
7	2	36.5631" Curved Horizontal Extrusion w/ Velcro Attached
8	2	36.5631" Curved Horizontal Extrusion w/ Velcro Attached
9	1	95.094"w Horizontal Extrusion w/ Steel Tape Applied
10	1	95.094"w Horizontal Extrusion w/ Steel Tape Applied
11	2	11.418"h Vertical Extrusion

Steps:

- 1) Attach curved extrusions [5 and 6] between verticals [4] and connectors as shown.
- 2) Attach curved extrusions [7 and 8] between verticals [4].
- 3) Attach verticals [11] between horizontals [9 and 10].
- 4) Attach header assembly between connectors located on panels as indicated.

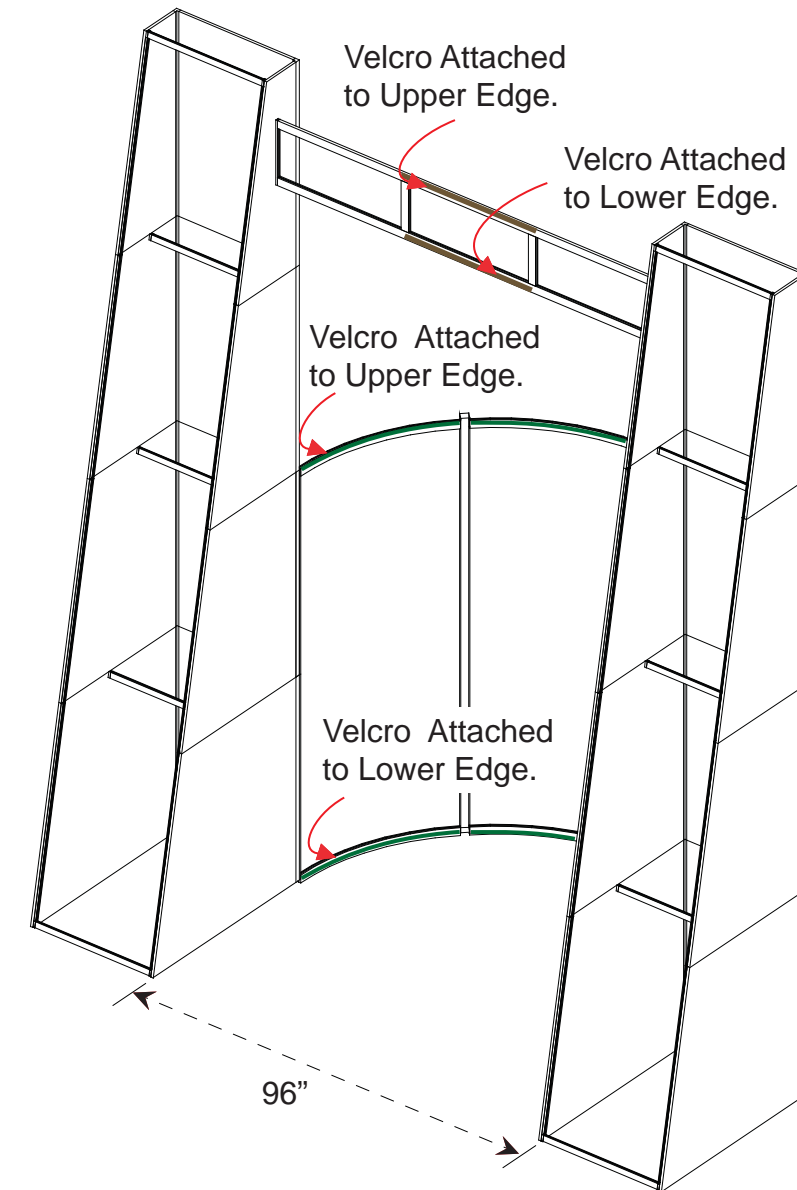
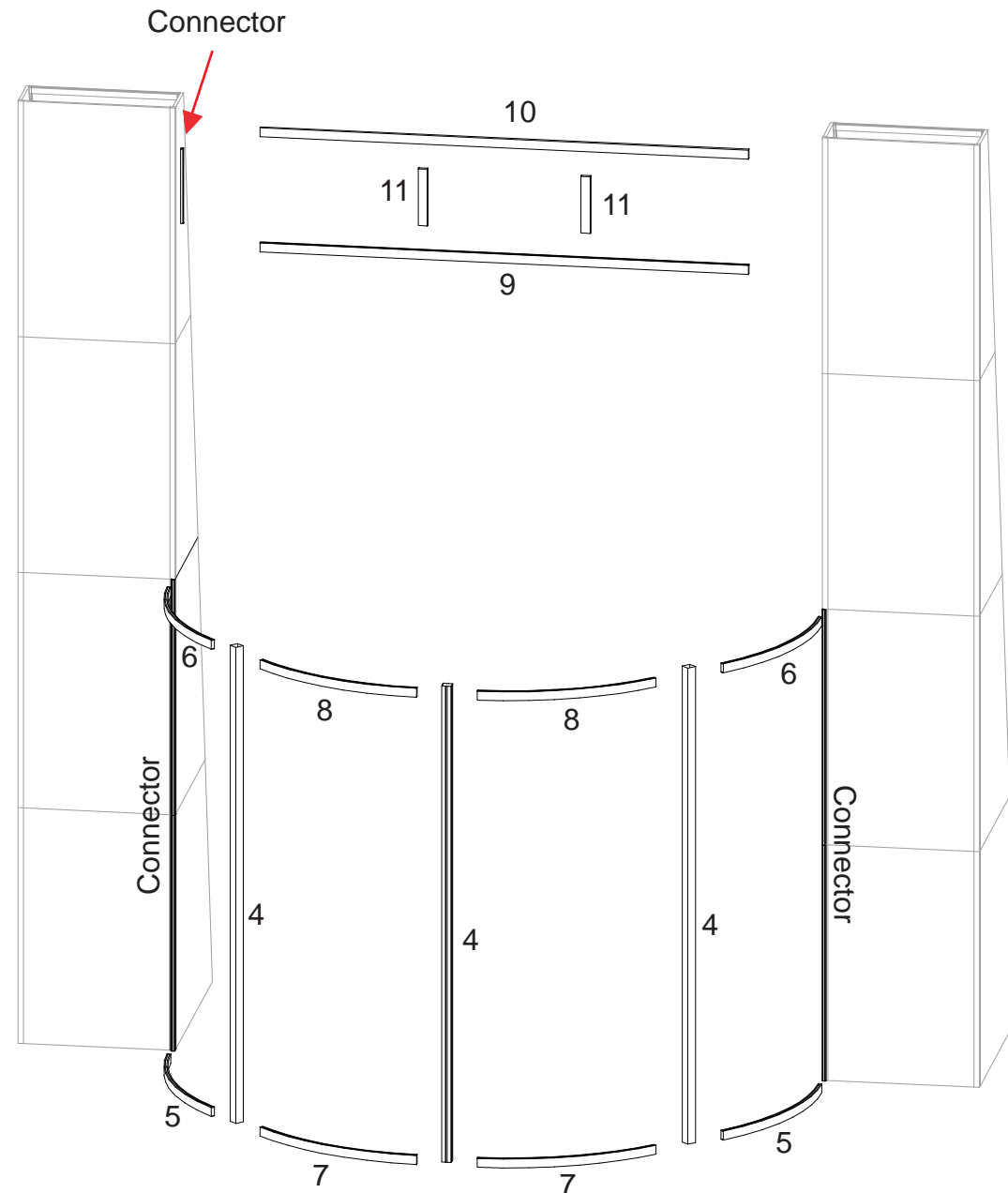

**WHEN DISASSEMBLING ALUMINUM EXTRUSION, TIGHTEN ALL SETSCREWS AND LOCKS TO PREVENT LOSS DURING SHIPPING**

866.652.2100

Item Number	Description
11	5.75"r x 38"h Half Curve Panel
12	5.75"r x 38"h Half Curve Panel
13	11.5"r x 42"h Quarter Curve Panel w/ Door
14	11.5"r x 42"h Quarter Curve Panel
15	11.5"r x 42"h Quarter Curve Panel
16	11.5"r x 42"h Quarter Curve Panel

Steps:

- 1) Assemble workstation base by starting at panel [11] and continue in numerical order.
- 2) Velcro shelf supports to inside of assembled large base.

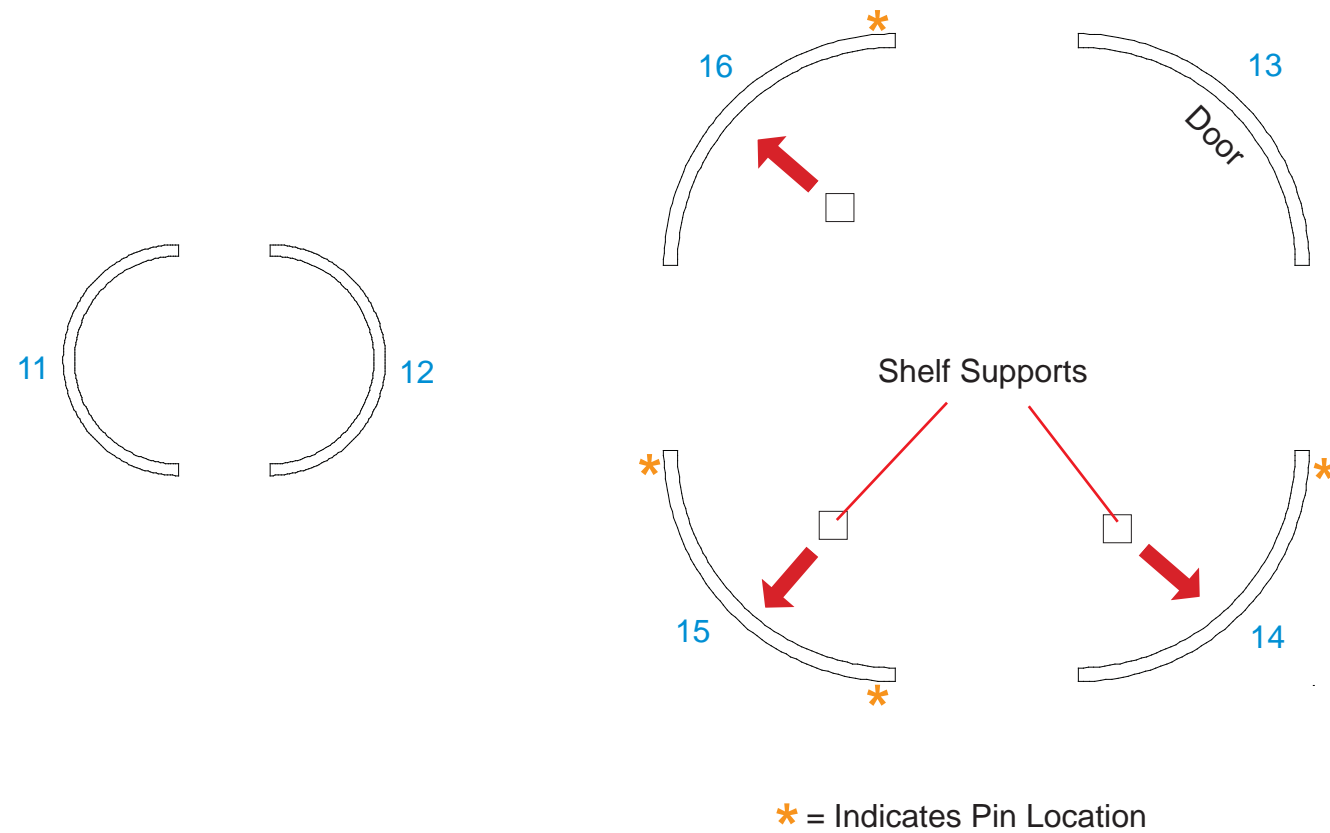

Steps:

- 3) Set internal shelf atop shelf supports.
- 4) Attach pins to large base where indicated.
- 5) Slide large counter on base, and set atop small base and pins.

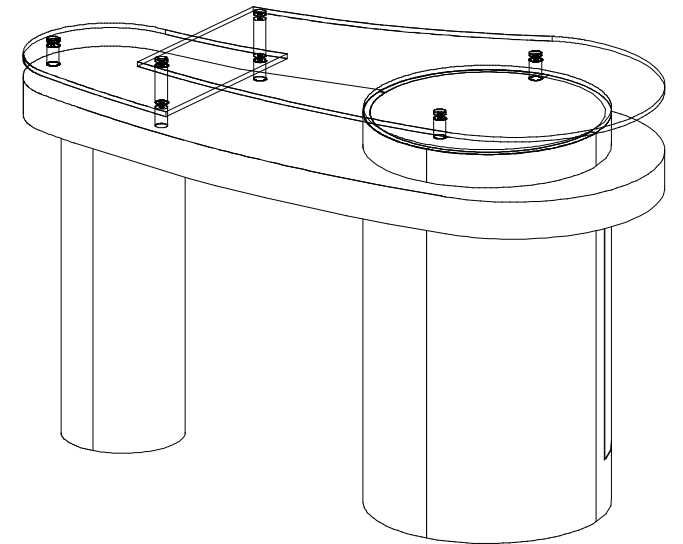
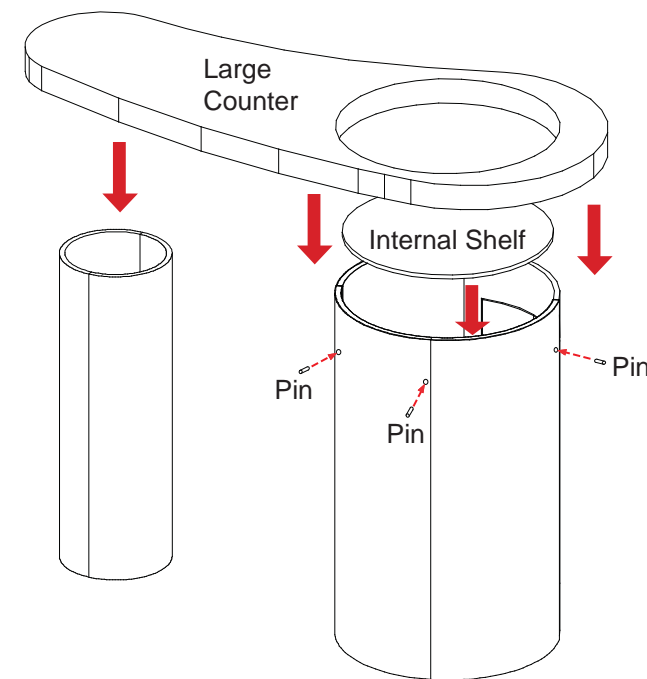

Steps:

- 6) Attach plex shelves to counter tops using stand-off barrels and caps as shown.

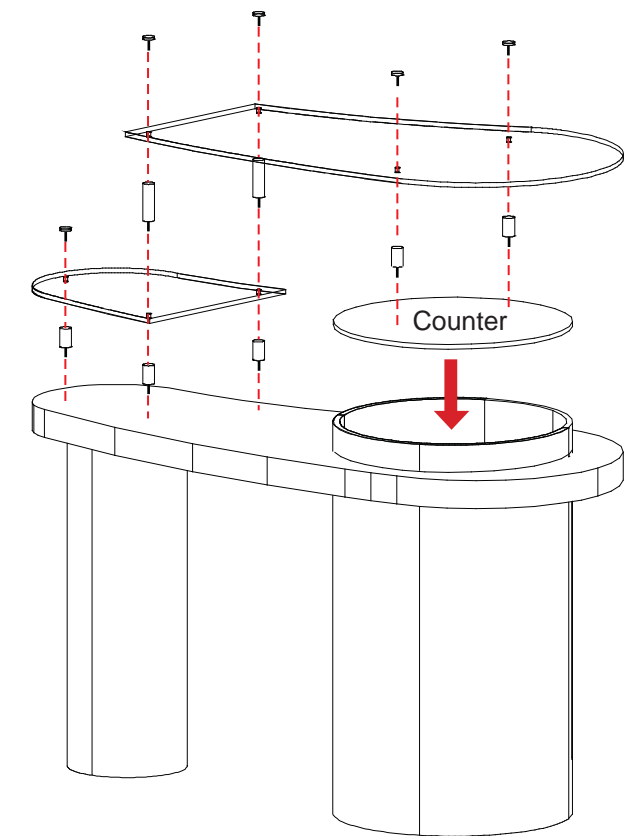

**WHEN DISASSEMBLING ALUMINUM EXTRUSION, TIGHTEN ALL SETSCREWS AND LOCKS TO PREVENT LOSS DURING SHIPPING**

866.652.2100

Item Number	Description
17	11.5"r x 38"h Quarter Curve Panel w/ Door
18	38"h T Connector
19	11.5"r x 38"h Quarter Curve Panel
20	11.5"r x 38"h Quarter Curve Panel
21	38"h T Connector
22	38"h Tapered Panel
23	11.5"r x 38"h Quarter Curve Panel
24	38"h Tapered Panel

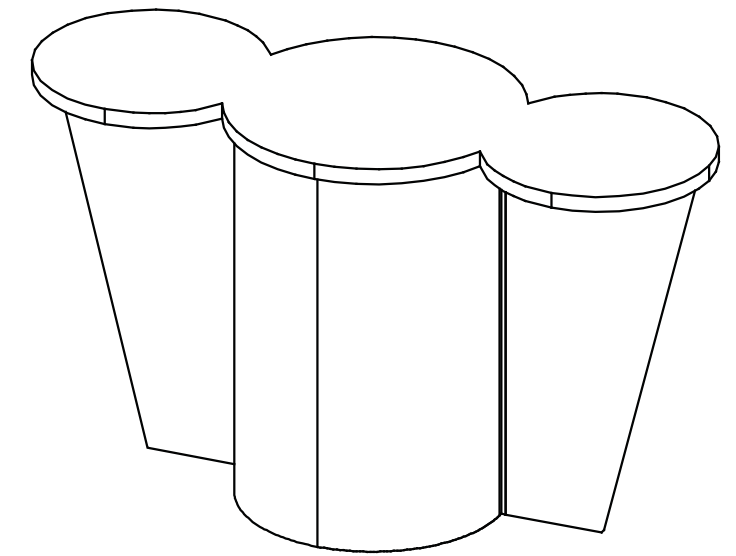

Steps:

- 1) Assemble counter base by starting at panel [17] and continue in numerical order.
- 2) Velcro shelf supports to inside of assembled base.
- 3) Set internal shelf atop supports.
- 4) Place counter top on assembled base.

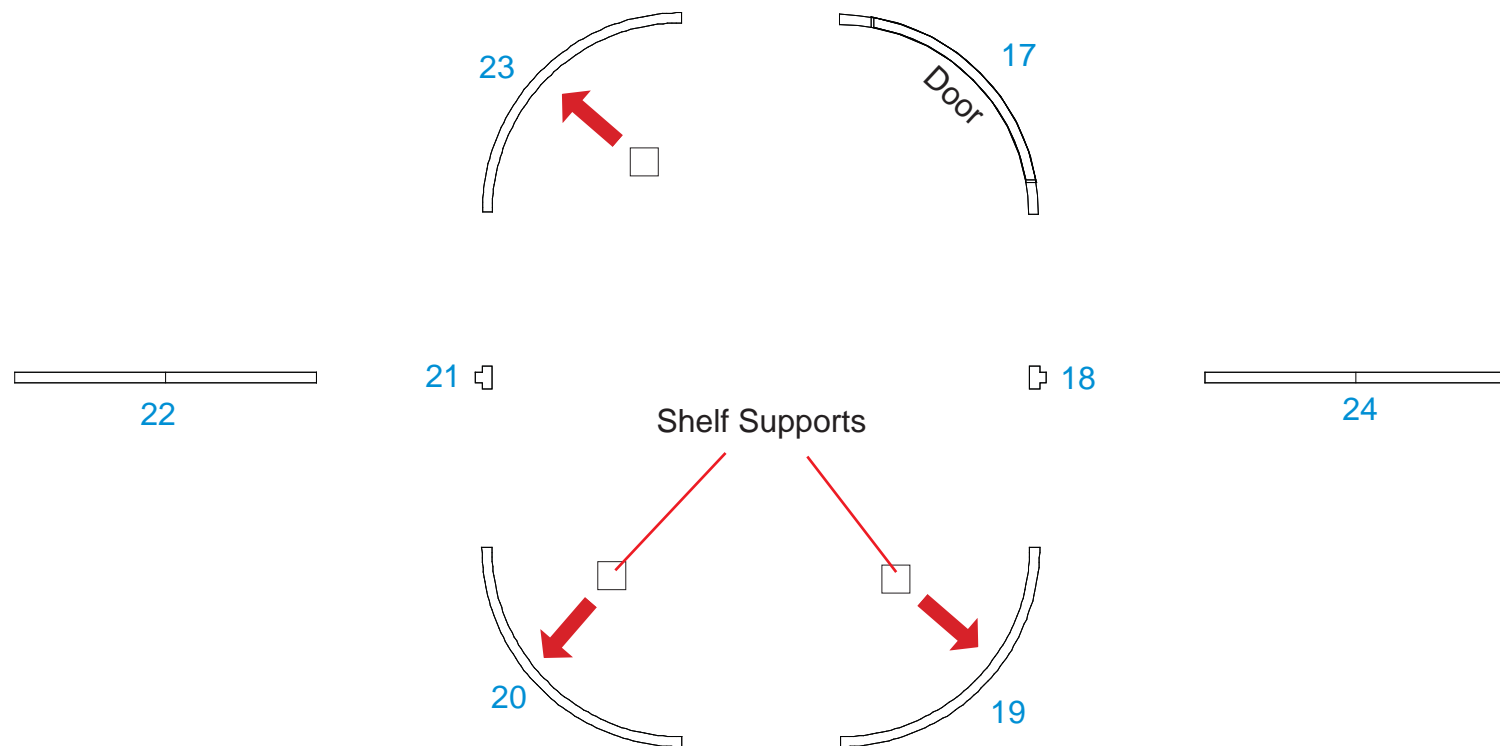

Set counter atop assembled base.

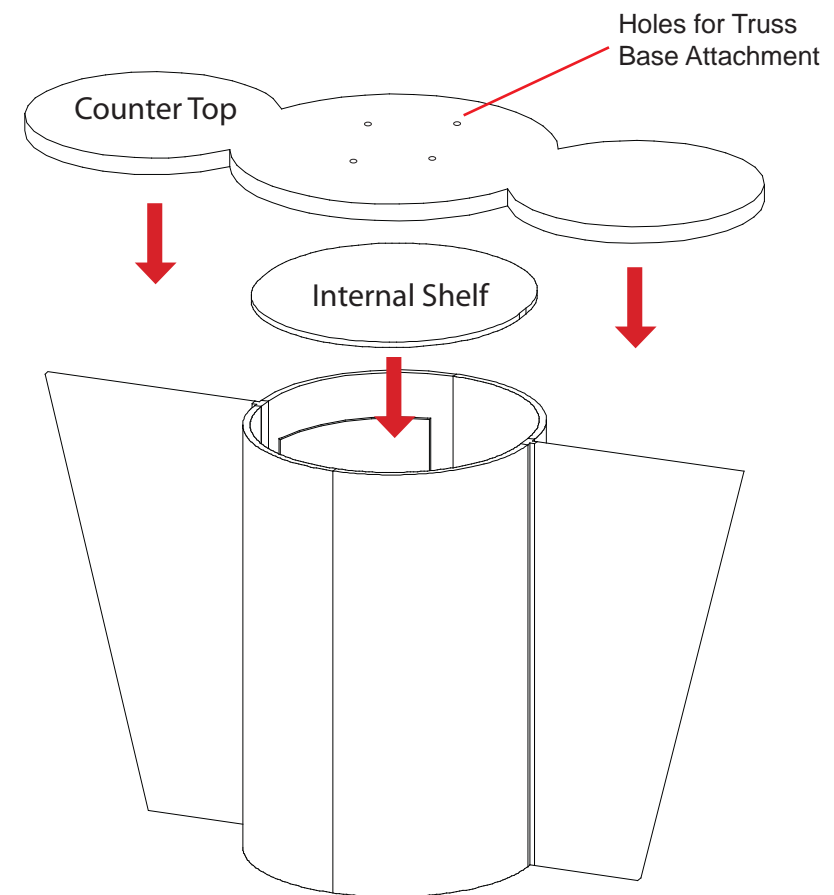

**WHEN DISASSEMBLING ALUMINUM EXTRUSION, TIGHTEN ALL SETSCREWS AND LOCKS TO PREVENT LOSS DURING SHIPPING**

866.652.2100

Item Number	Description
25	11.5"r x 38"h Quarter Curve Panel
26	11.5"r x 38"h Quarter Curve Panel
27	38"h T Connector
28	38"h Tapered Panel
29	11.5"r x 38"h Quarter Curve Panel
30	11.5"r x 38"h Quarter Curve Panel w/ Door
31	38"h T Connector
32	38"h Tapered Panel

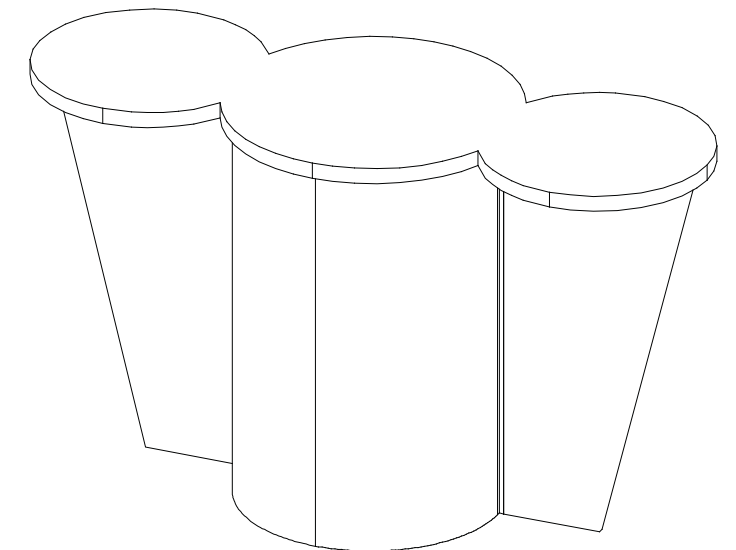

Steps:

- 1) Assemble counter base by starting at panel [25] and continue in numerical order.
- 2) Velcro shelf supports to inside of assembled base.
- 3) Set internal shelf atop supports.
- 4) Place counter top on assembled base.

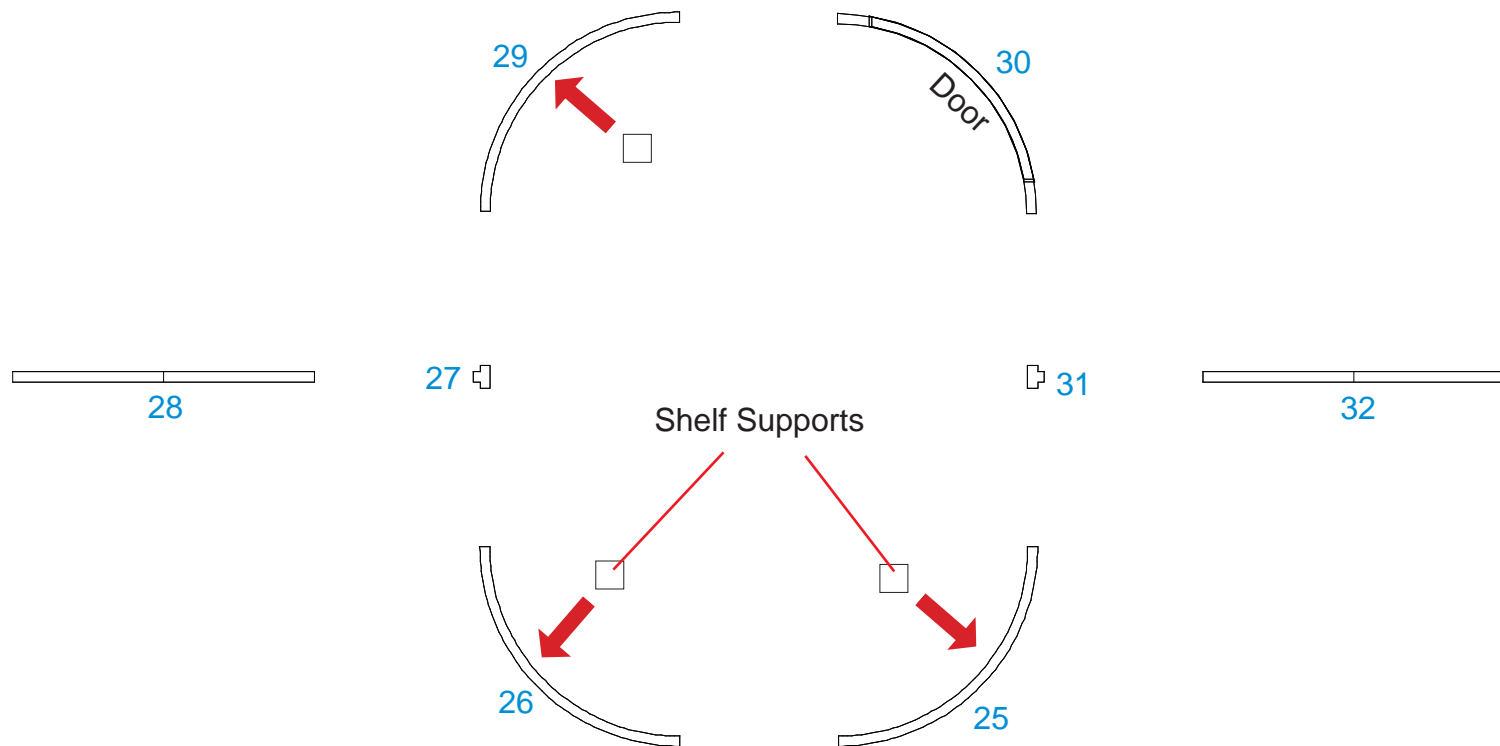

Set counter atop assembled base.

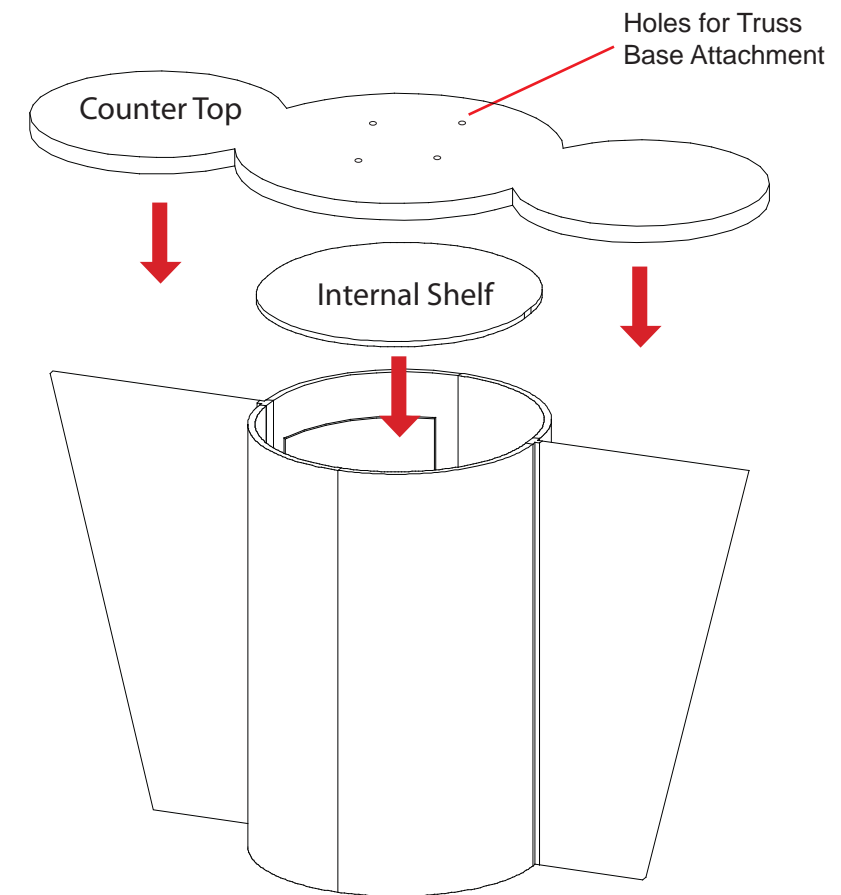

**WHEN DISASSEMBLING ALUMINUM EXTRUSION, TIGHTEN ALL SETSCREWS AND LOCKS TO PREVENT LOSS DURING SHIPPING**

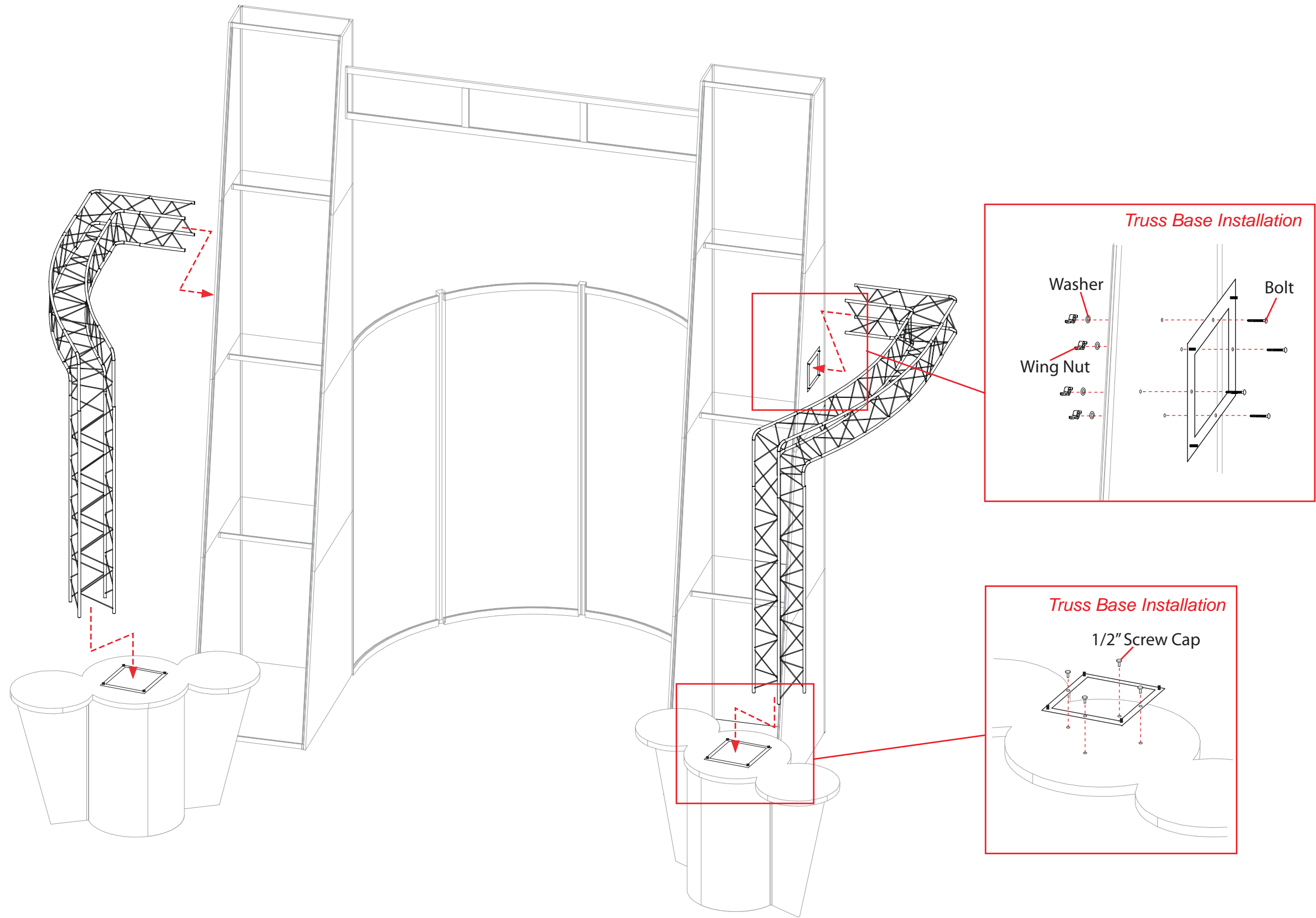

WHEN DISASSEMBLING ALUMINUM EXTRUSION, TIGHTEN ALL SETSCREWS AND LOCKS TO PREVENT LOSS DURING SHIPPING

866.652.2100

Item Number	Description
33	14.125" w x 30" h Flat Panel
34	14.125" w x 30" h Flat Panel
35	14.125" w x 30" h Flat Panel
36	14.125" w x 30" h Flat Panel
37	30" h 4-Way Connector

- Steps:
- 1) Assemble counter base by connecting flat panels to 4-way connector [37].
  - 2) Velcro shelf supports to inside of assembled base.
  - 3) Set internal shelf atop supports.
  - 4) Place counter top on assembled base.

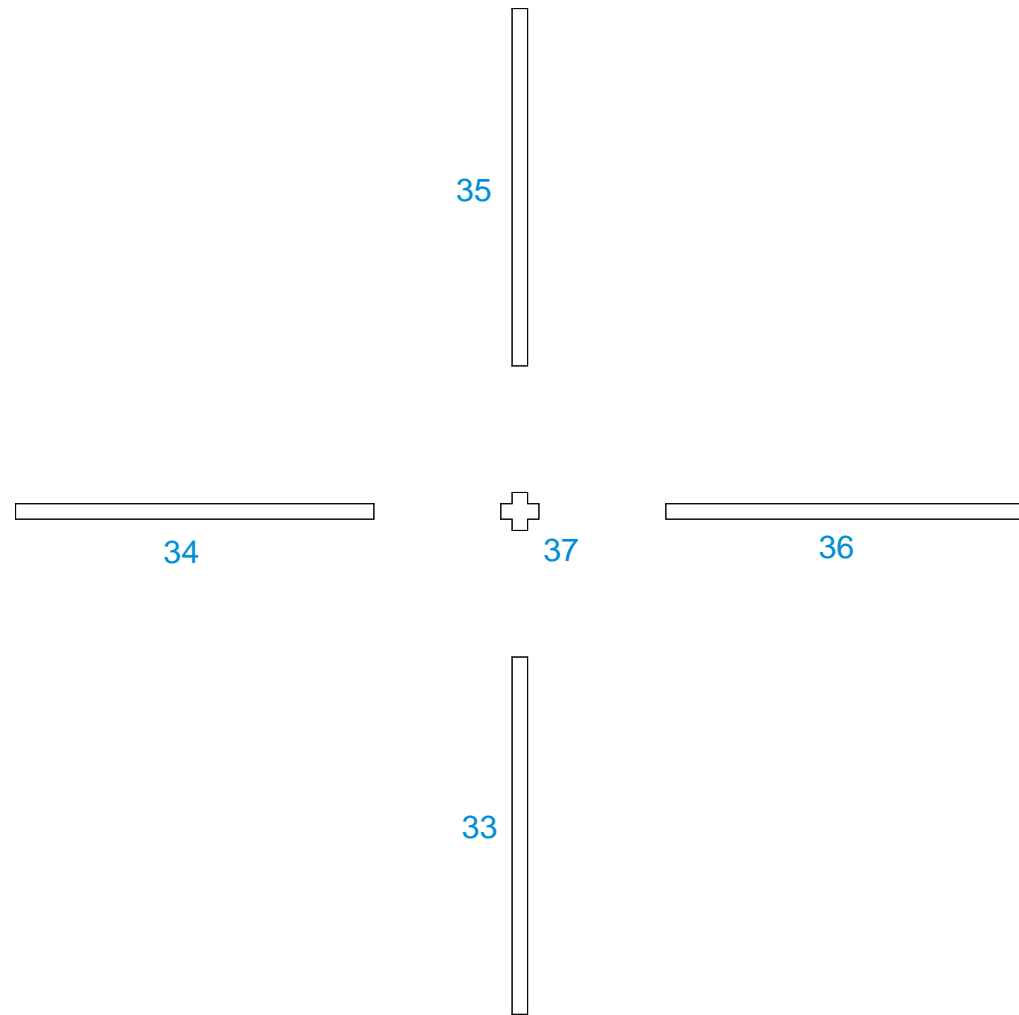
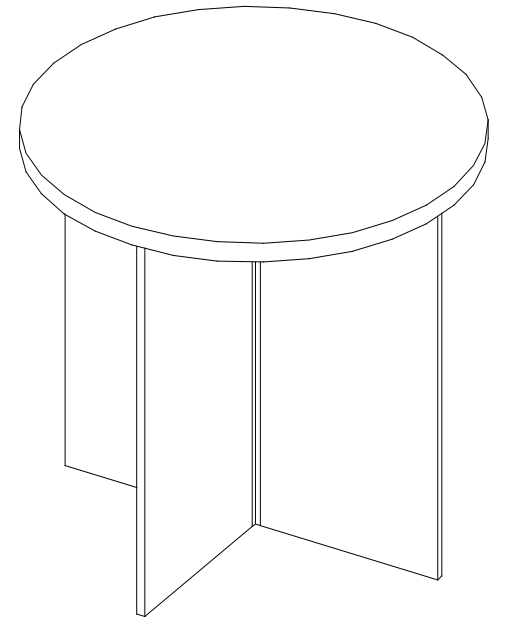

Set counter atop assembled base.

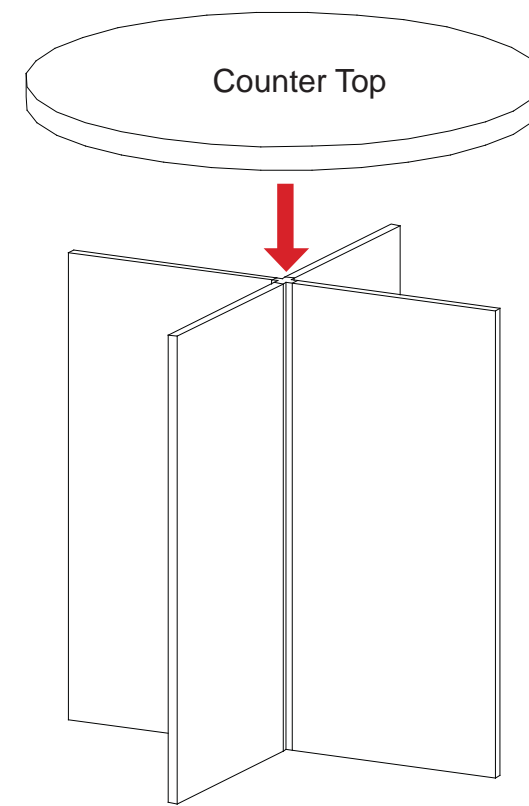

**WHEN DISASSEMBLING ALUMINUM EXTRUSION, TIGHTEN ALL SETSCREWS AND LOCKS TO PREVENT LOSS DURING SHIPPING**

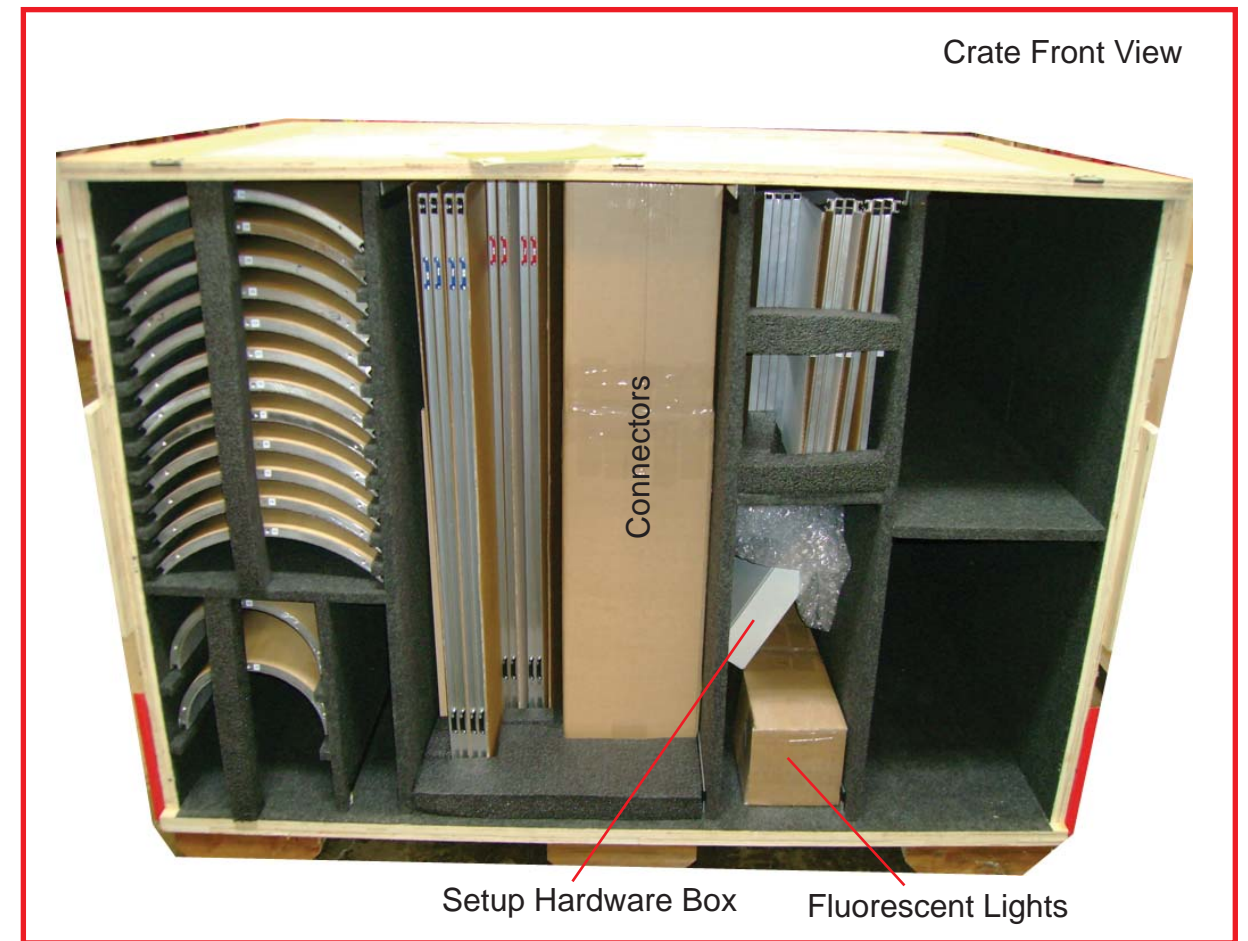
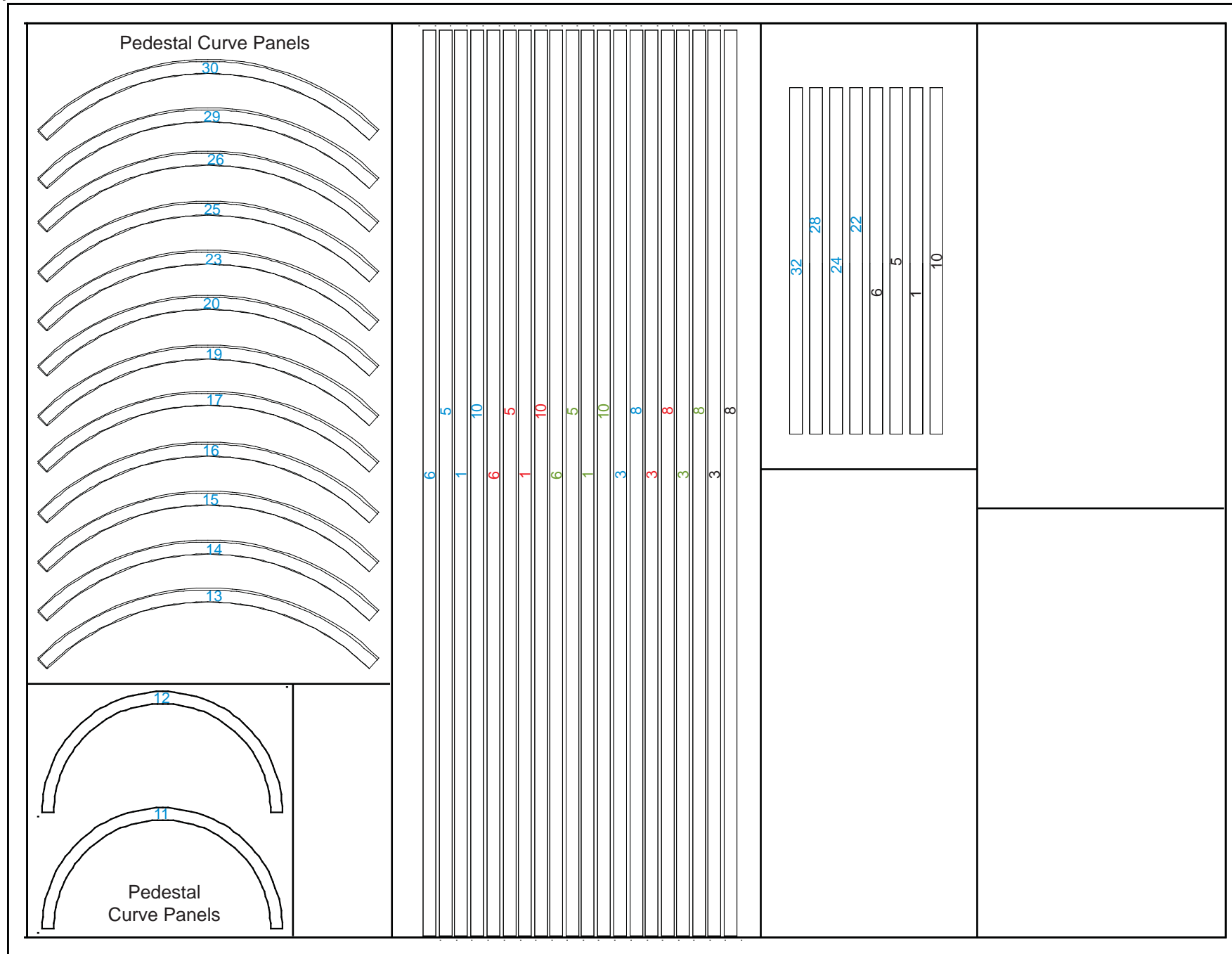

**WHEN DISASSEMBLING ALUMINUM EXTRUSION, TIGHTEN ALL SETSCREWS AND LOCKS TO PREVENT LOSS DURING SHIPPING**

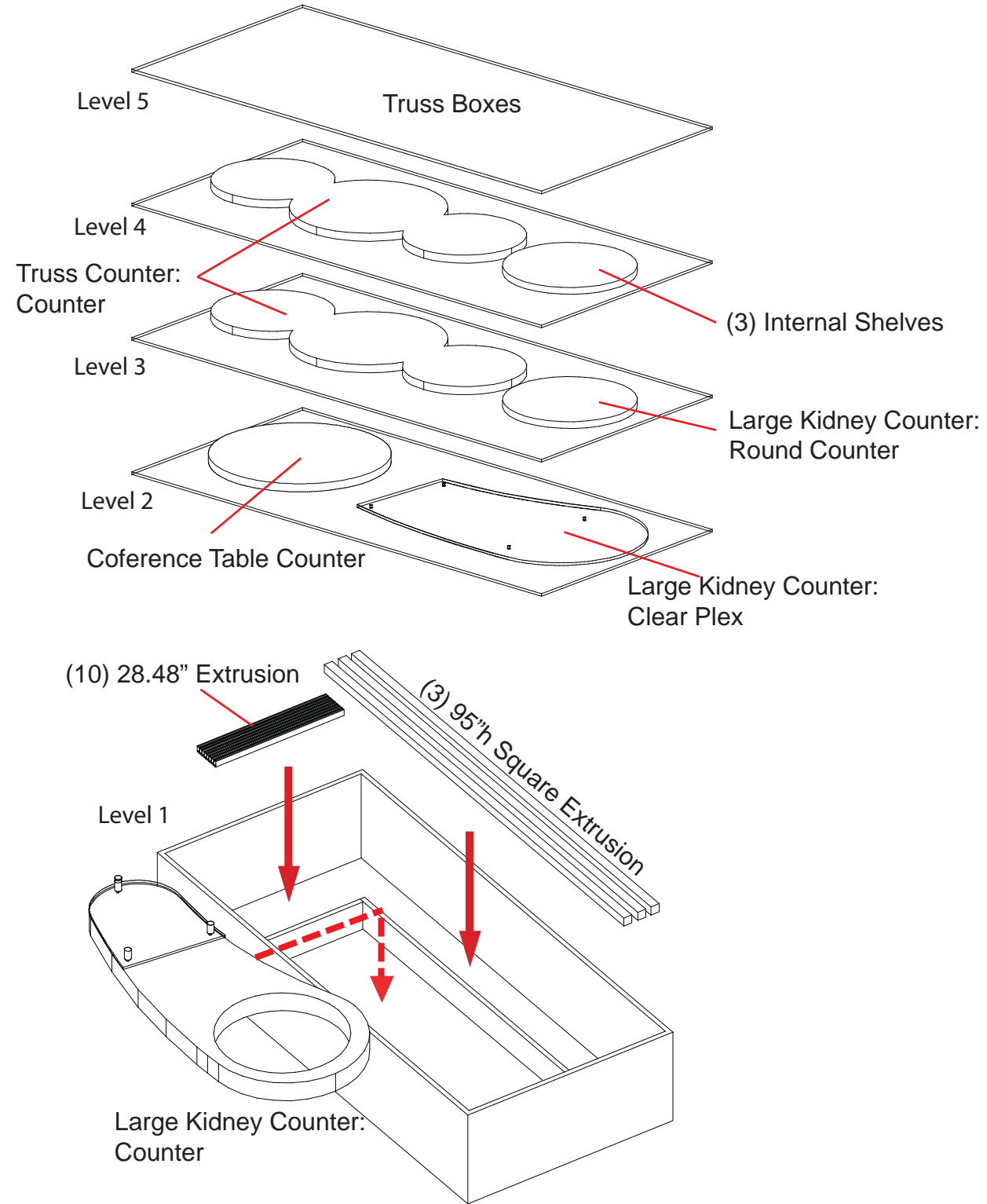

WHEN DISASSEMBLING ALUMINUM EXTRUSION, TIGHTEN ALL SETSCREWS AND LOCKS TO PREVENT LOSS DURING SHIPPING