

Plan View

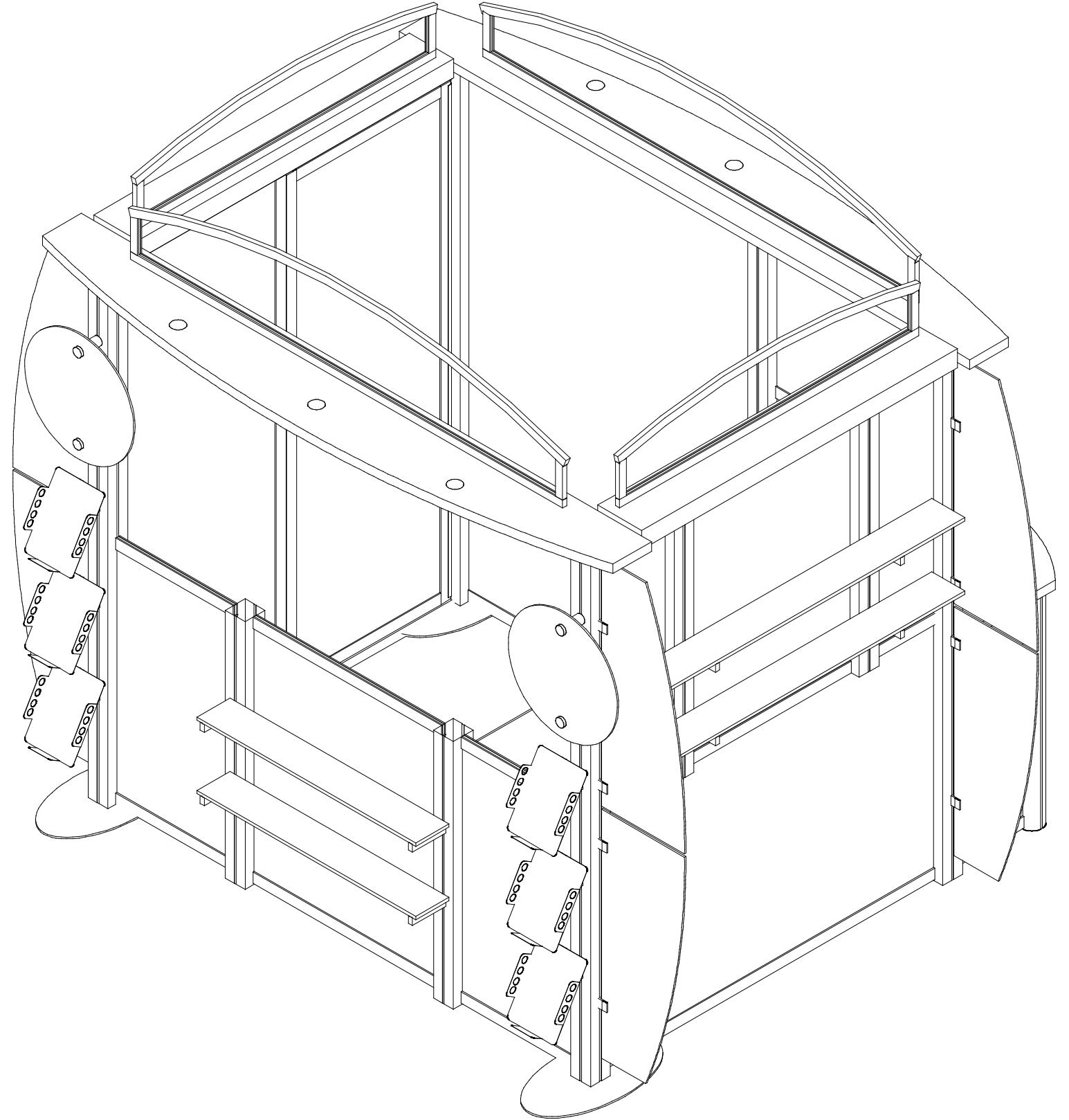

WHEN DISASSEMBLING ALUMINUM EXTRUSION, TIGHTEN ALL SETSCREWS AND LOCKS TO PREVENT LOSS DURING SHIPPING

# visionary™ IDESIGNS

## Using Your Setup Instructions

The Visionary Designs Setup Instructions are created specifically for your configuration. They are laid out sequentially, including an exploded view of the entire display, and then a logical series of detailed steps to assemble the main structure and components. We encourage you to study the instructions **before** attempting to assemble your exhibit.

Each page reminds you to tighten the setscrews after disassembling your exhibit to prevent loss of the locks and setscrews (see below in RED). This is **VERY IMPORTANT**.

## Cleaning and Packing Your Display

- 1) Use care when cleaning aluminum extrusion or acrylic inserts. Use only non-abrasive cleaners.
- 2) When cleaning laminate inserts or countertops, use mild cleansers and a soft material such as cotton.
- 3) Keep all display components away from extreme heat and long exposure to sunlight to avoid warping and fading.
- 4) Retain all packing material. It will make re-packing much easier and will reduce the likelihood of shipping damage.



**The Tool**

Most Visionary Designs exhibits can be assembled with the supplied Hex Key Tool. Occasionally, a flat head screwdriver may be required.



**Typical Connection**

Most horizontal extrusion connections have a patented expandable lock. This lock inserts into the groove of an opposing extrusion. Tightening the lock with the Hex Key Tool expands the lock and creates a strong positive connection.



**Typical Connection (cont'd)**



**Numbered Label**

Each extrusion contains a numbered label which corresponds with setup instructions. The label is located within a groove of the extrusion (when possible). With Visionary Designs the labels contain Black numbers unless otherwise specified.



**Horizontal Inline Connection** (remove only one setscrew)

Remove only (1) setscrew when disassembling. Replace setscrew in extrusion after assembling it. Before packing, replace setscrew in extrusion to avoid losing it.

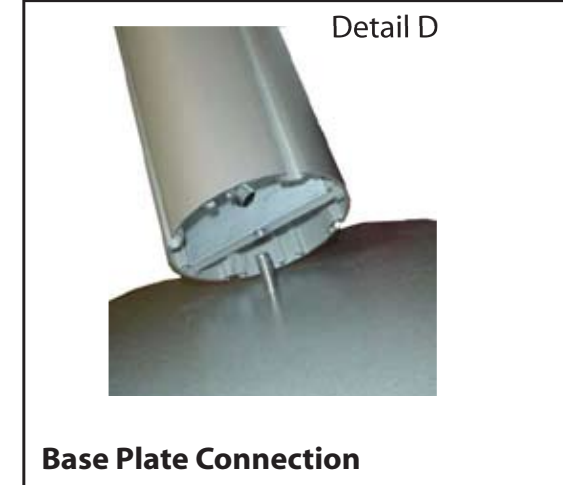

**Base Plate Connection**

Attach base plate to round or square vertical extrusion using the bolt provided. Be careful not to strip the threads.

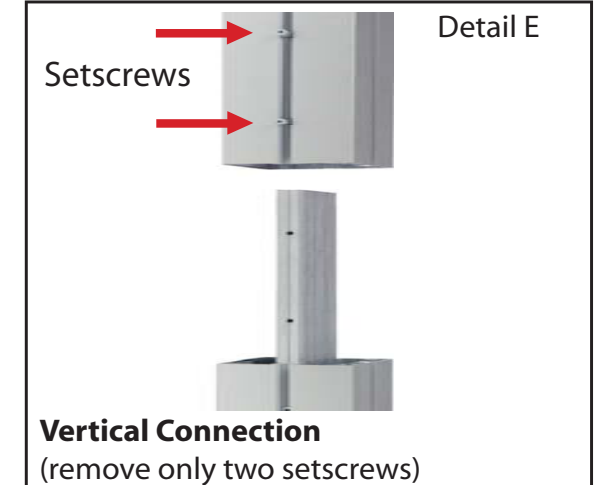

**Vertical Connection**  
(remove only two setscrews)

When vertical extrusions are packed in portable cases rather than crates or tubs, they must be broken down into smaller sections which then require assembly.

Remove only (2) setscrews when disassembling. Replace setscrews in extrusion after assembling it. Before packing, replace setscrews in extrusion to avoid losing them.

**WHEN DISASSEMBLING ALUMINUM EXTRUSION, TIGHTEN ALL SETSCREWS AND LOCKS TO PREVENT LOSS DURING SHIPPING**

866.652.2100

Item	Qty.	Description
1	1	Oval Base Plate
2	1	84" h Square Vertical Extrusion w/ Canopy Attachment
3	1	84" h Square Vertical Extrusion
4	1	83.75" h Square Vertical Extrusion w/ Canopy Attachment
5	3	28" Horizontal Extrusion
5a	1	28" Horizontal Extrusion for Monitor Mount Attachment
6	2	52" Horizontal Extrusion w/ Velcro Attached

Steps:

- 1) Attach vertical extrusion [4] to oval base plate [1], see detail D on general info page.
- 2) Attach horizontal extrusions [5] between vertical extrusions [2 and 3], placing inserts as indicated.
- 3) Attach horizontal extrusions [6] between vertical extrusions [3 and 4] as shown.
- 4) Apply graphics to assembled backwall, see attaching graphic details.

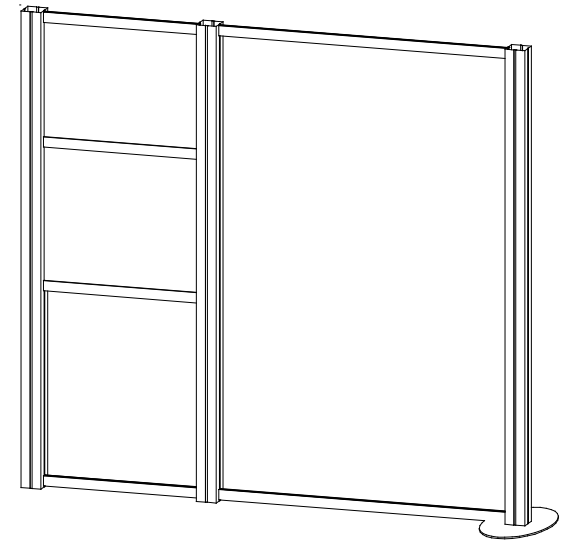

**Example of Monitor Mount Plate**

Connector

Insert connectors into groove of extrusion. Then attach mount by tightening screws on frontside of monitor mount as shown in illustration.

Attach monitor brackets to back of monitor.

Attach wall plate to vertical extrusion using supplied bolts

Hook monitor brackets over top of wall plate, then secure with safety bolts to bottom of monitor brackets.

Modul Extrusion

Panel

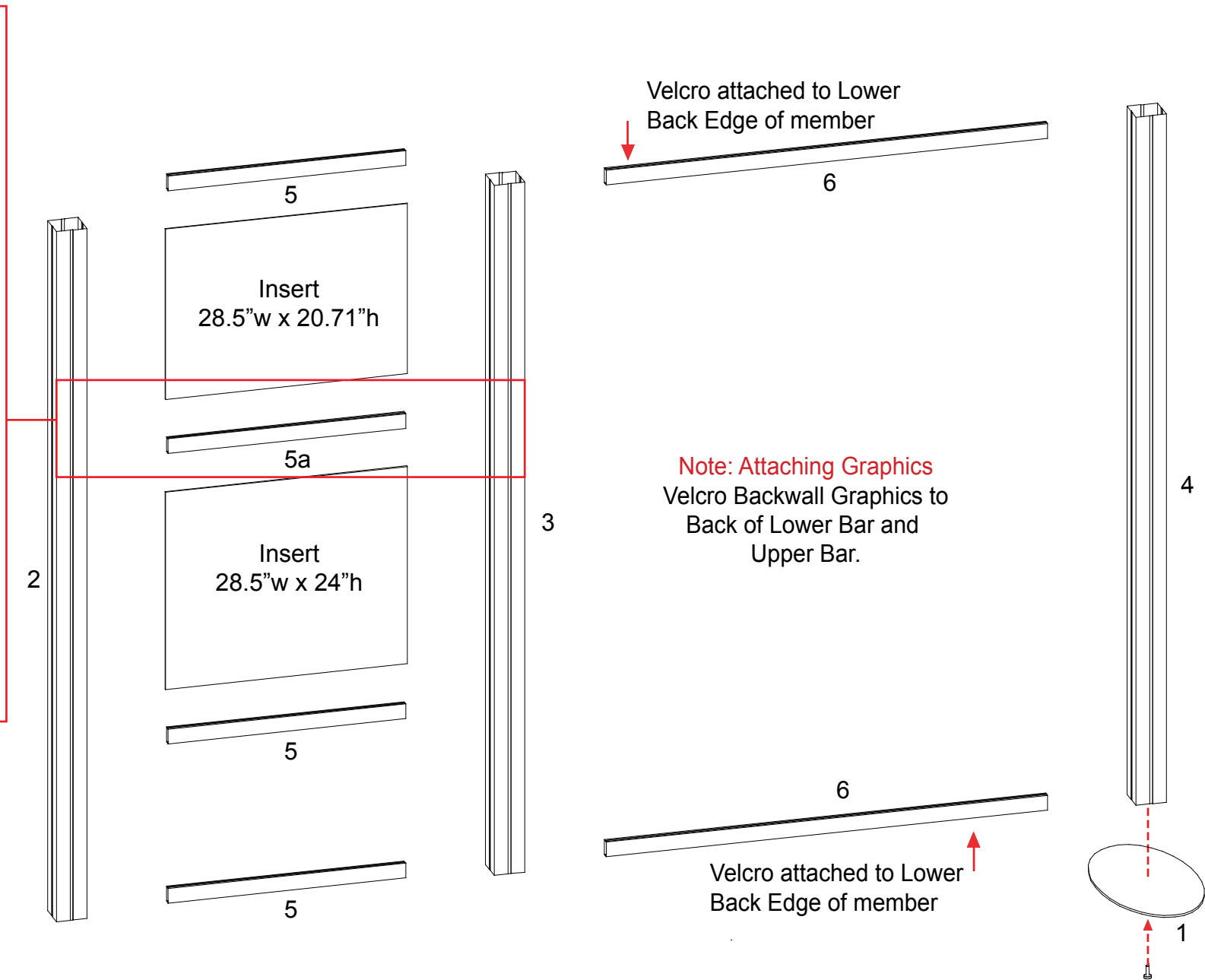

**WHEN DISASSEMBLING ALUMINUM EXTRUSION, TIGHTEN ALL SETSCREWS AND LOCKS TO PREVENT LOSS DURING SHIPPING**

866.652.2100

Item	Qty	Description
7	1	38" h Round Vertical Extrusion
7a	1	38" h 135° Corner Extrusion w/ Door Stopper
8	1	38" h Round Vertical Extrusion
8a	1	38" h 135° Corner Extrusion w/ Door Hinges
9	4	12.5" w Horizontal Extrusion
10	2	Curved Horizontal Extrusion

Steps

- 1) Attach corner extrusions [7a and 7b] to vertical extrusions [7 and 8] as shown below, see Pressure Screw Attachment detail.
- 2) Attach lower horizontal extrusions [9 and 10] between vertical extrusions as shown.
- 3) Attach door and place inserts as indicated.
- 5) Attach upper horizontal extrusions [9 and 10] between vertical extrusions and atop inserts and door.
- 6) Velcro shelf supports to inside of assembled counter, then set internal shelf atop supports.
- 7) Place counter atop assembled counter base.

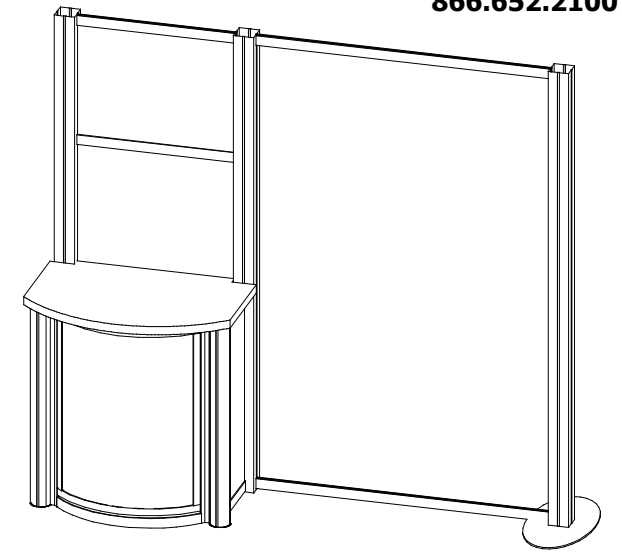

**Pressure Screw Attachment**

V10 Pressure Screw

**Note: V10 Detail**  
Slide V10 Connector in between vertical extrusions [7&7a and 8&8a]. Note:[7&7a and 8&8a] should remain assembled when shipping.

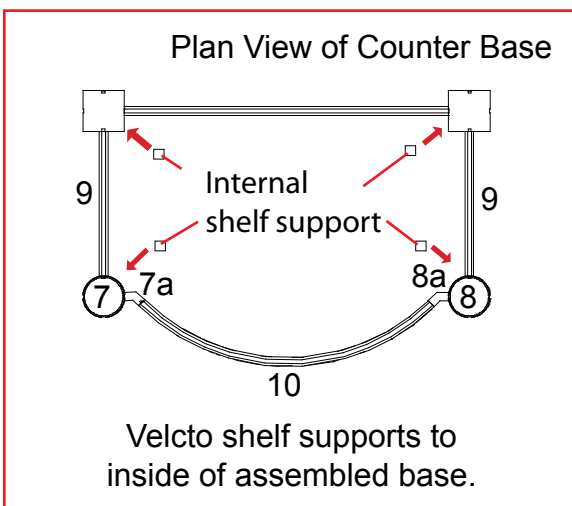
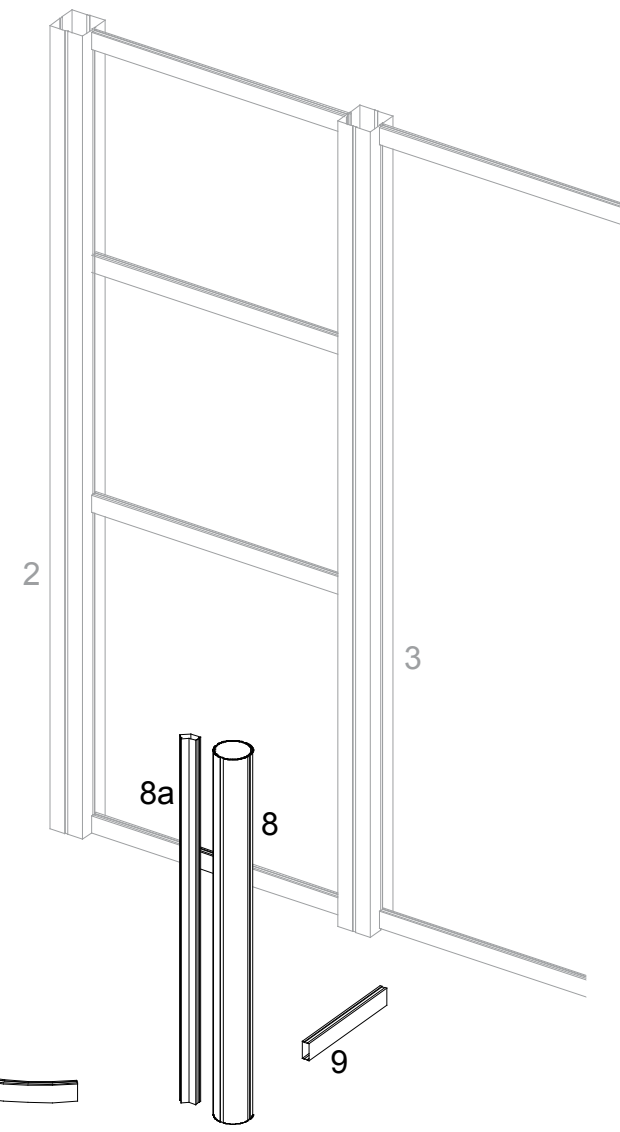

**Door Attachment**

Slide pin into hinge attached to vertical. Slide door hinge atop pin.

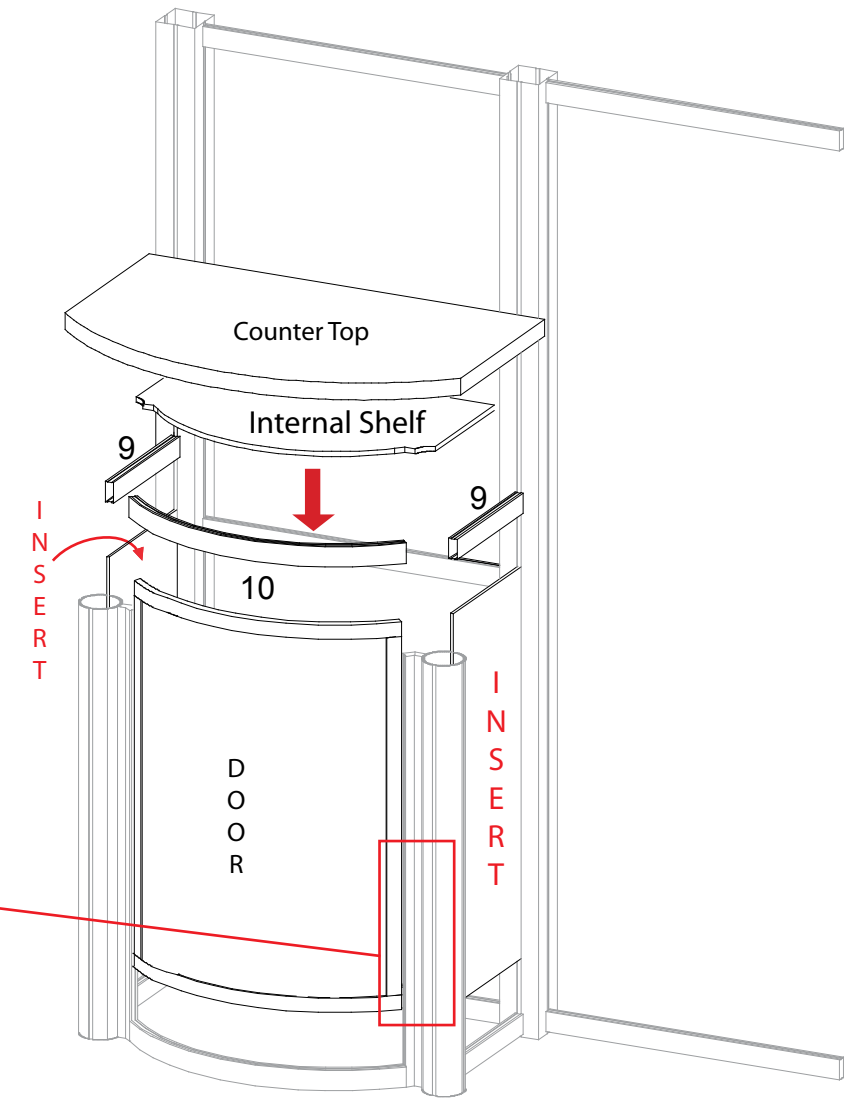

**WHEN DISASSEMBLING ALUMINUM EXTRUSION, TIGHTEN ALL SETSCREWS AND LOCKS TO PREVENT LOSS DURING SHIPPING**

866.652.2100

Item	Qty.	Description
10	1	78"w Horizontal Extrusion
11	1	5.862"w Vertical Extrusion
12	1	5.862"w Vertical Extrusion
13	1	80.638"w Curved Horizontal Extrusion

**Steps**

- 1) Attach horizontal extrusion [10] to top of ceiling using bolts supplied.
- 2) Attach vertical extrusions [11 and 12] to left and right side of extrusion [10].
- 3) Attach curved extrusions [13] atop vertical extrusions [11 and 12].
- 4) Attach ceiling with assembled frame to top of assembled backwall using bolts provided.
- 5) Attach wings to assembled backwall as shown.

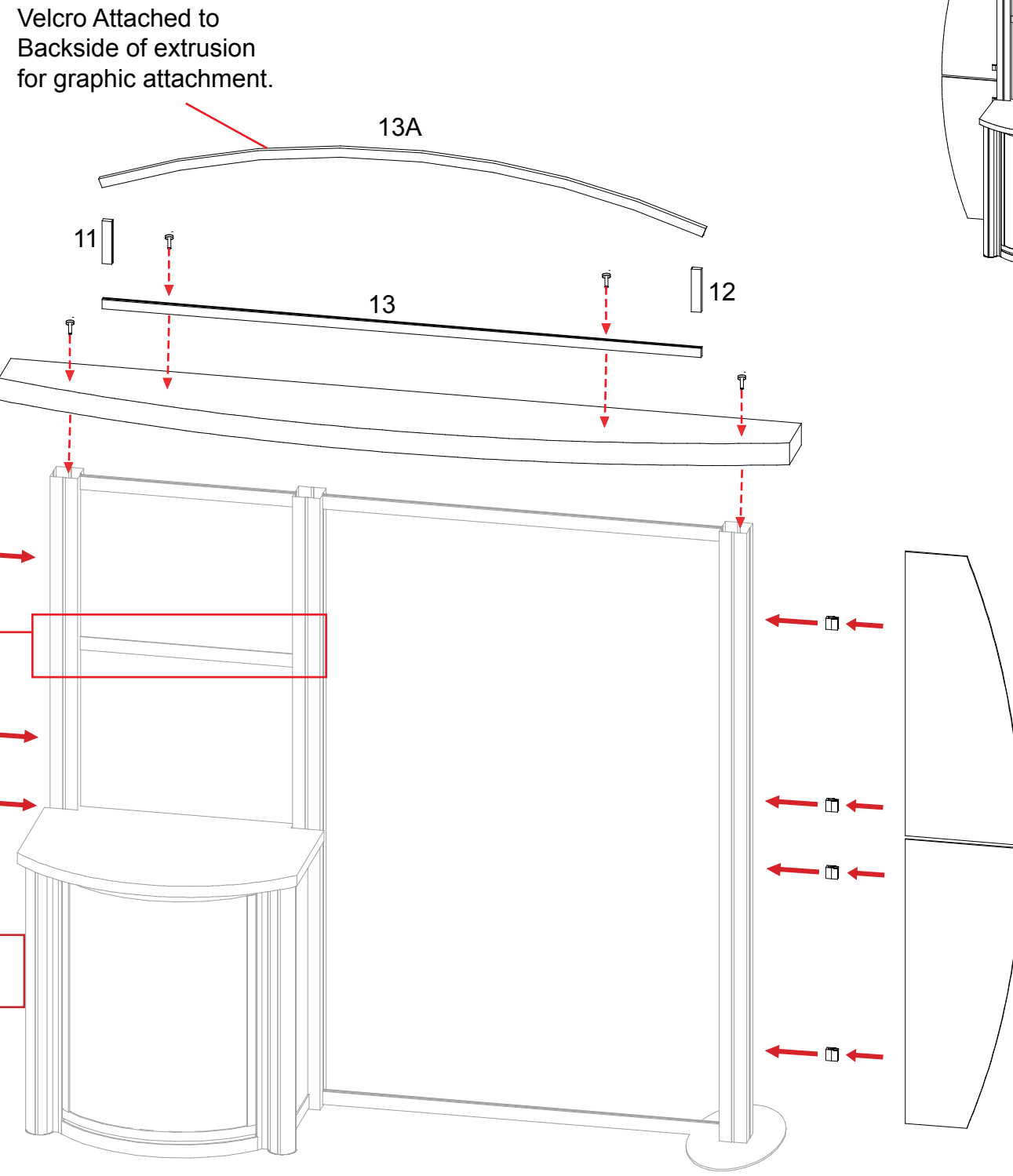
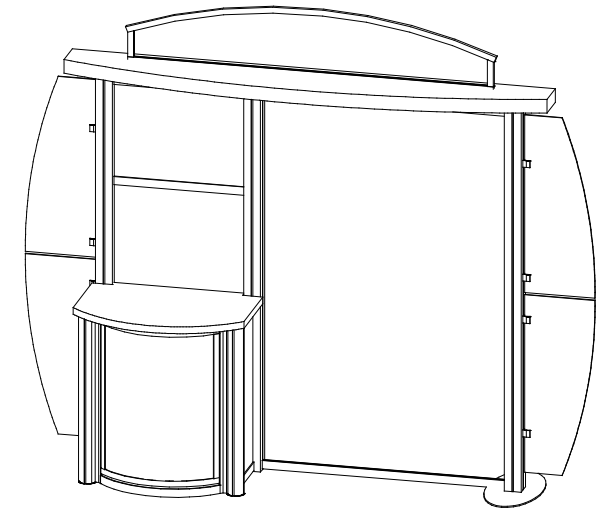

**Example of Monitor Mount Plate**

Attach monitor brackets to back of monitor.

**Wing Attachment**

When desired location is found, tighten set screw to secure.

**WHEN DISASSEMBLING ALUMINUM EXTRUSION, TIGHTEN ALL SETSCREWS AND LOCKS TO PREVENT LOSS DURING SHIPPING**

866.652.2100

Item	Qty.	Description
1	2	Oval Base Plate
14	1	83.75" h Square Vertical Extrusion w/ Canopy Attachment
15	1	83.75" h Square Vertical Extrusion w/ Canopy Attachment
16	1	42" h Square Vertical Extrusion
17	1	42" h Square Vertical Extrusion
18	4	21.2085" w Horizontal Extrusion
19	2	34" w Horizontal Extrusion
20	1	83.583" w Horizontal Extrusion

Steps:

- 1) Attach vertical extrusion [14 and 15] to oval base plate [1], see detail D on general info page.
- 2) Attach horizontal extrusions [18 and 19] between vertical extrusions [14, 15, 16 and 17], placing inserts as indicated.
- 3) Attach horizontal extrusion [20] between vertical extrusions [14 and 15] as shown.
- 4) Apply graphic to assembled backwall, see attaching graphic details.

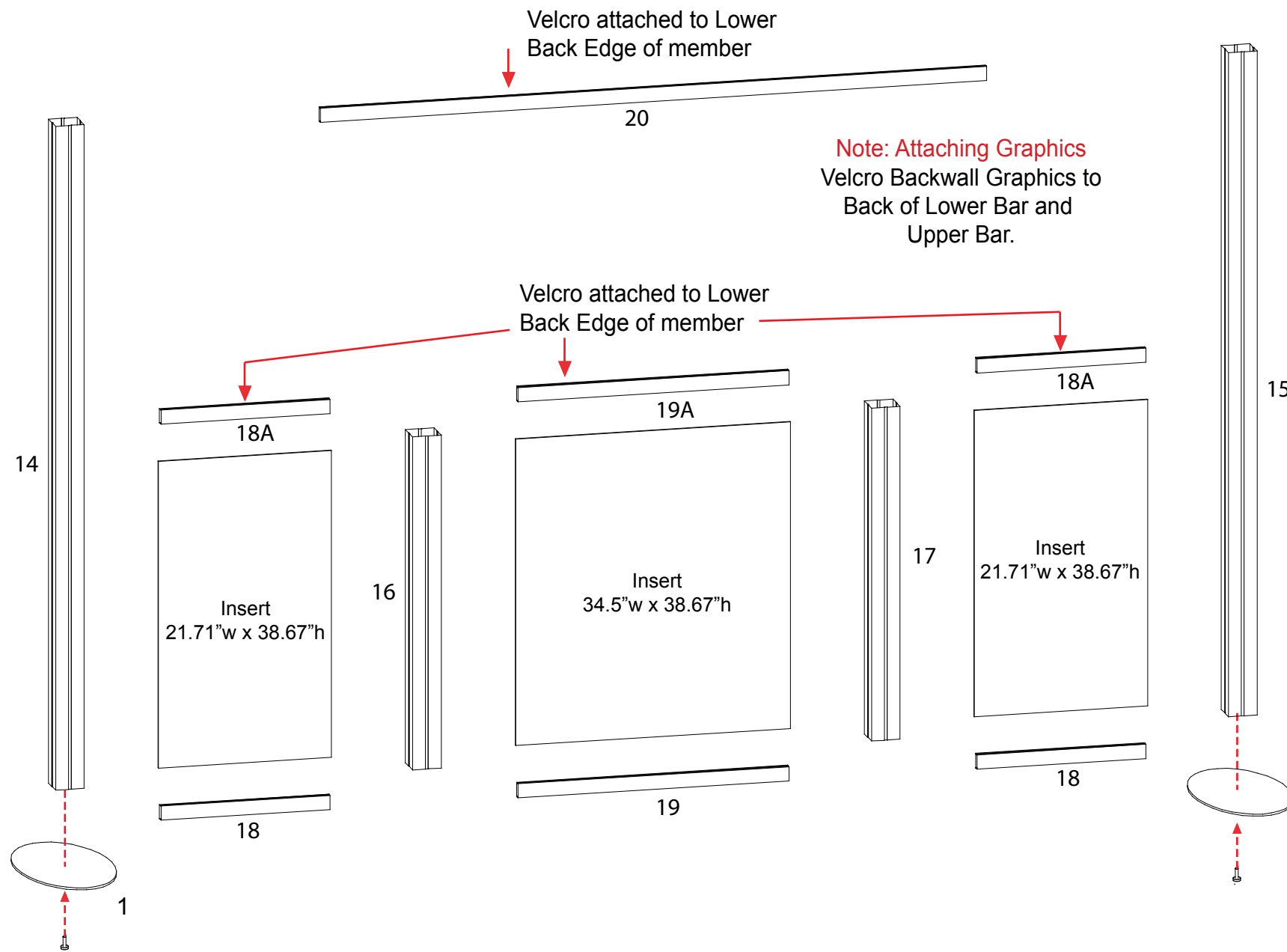
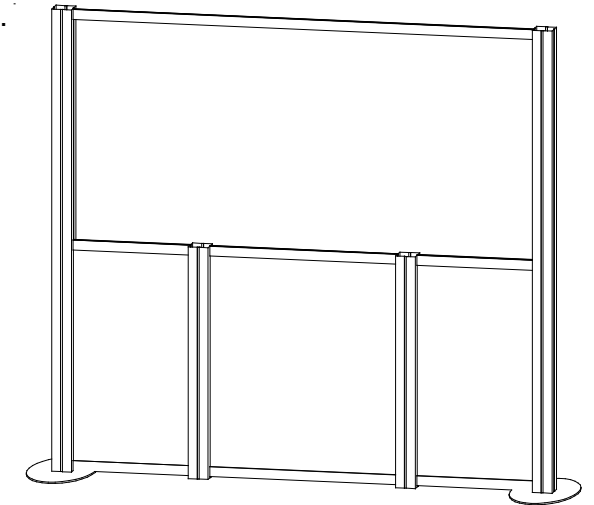

**WHEN DISASSEMBLING ALUMINUM EXTRUSION, TIGHTEN ALL SETSCREWS AND LOCKS TO PREVENT LOSS DURING SHIPPING**

866.652.2100



Item	Qty.	Description
10	1	78" w Horizontal Extrusion
11	1	5.862" w Vertical Extrusion
12	1	5.862" w Vertical Extrusion
13	1	80.638" w Curved Horizontal Extrusion

**Steps**

- 1) Attach horizontal extrusion [10] to top of ceiling using bolts supplied.
- 2) Attach vertical extrusions [11 and 12] to left and right side of extrusion [10].
- 3) Attach curved extrusions [13] atop vertical extrusions [11 and 12].
- 4) Attach ceiling with assembled frame to top of assembled backwall using bolts provided.
- 5) Attach wings to assembled backwall as shown.

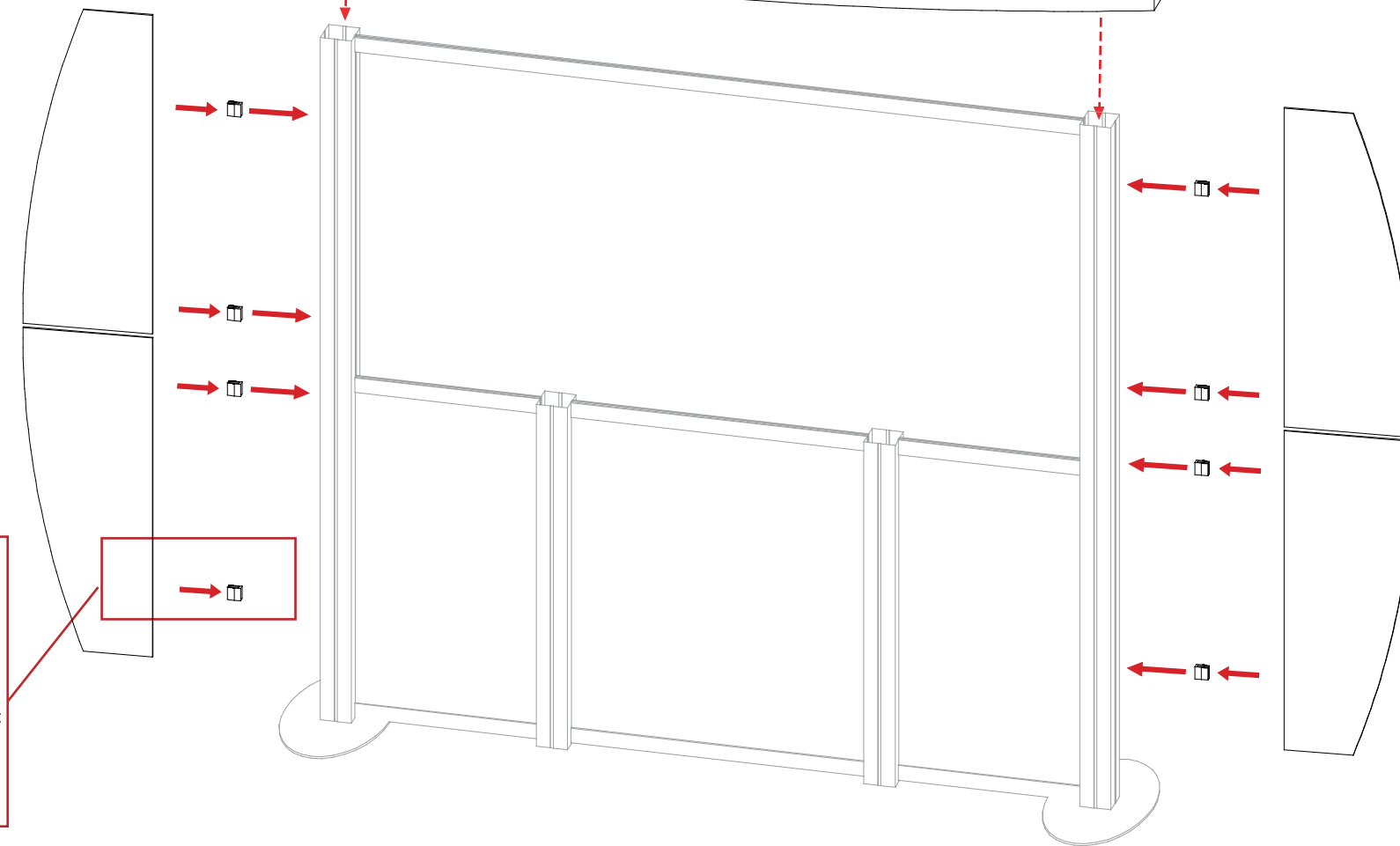
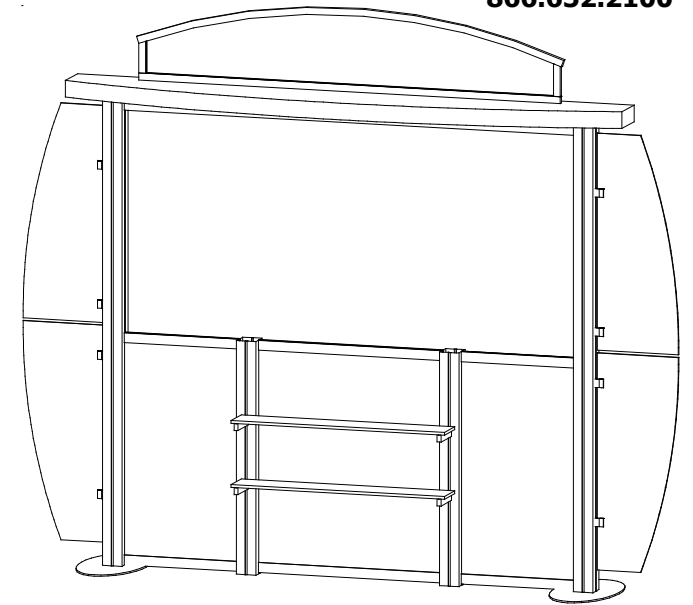
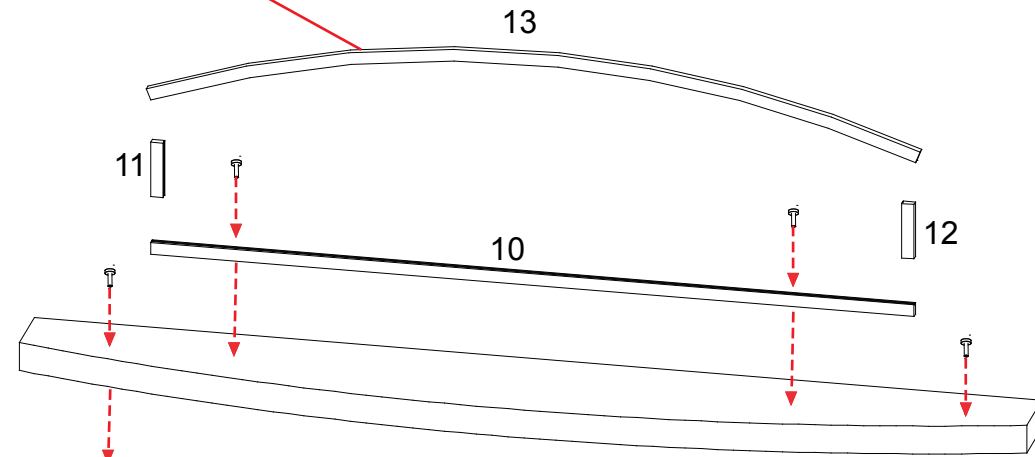
Velcro Attached to Backside of extrusion for graphic attachment.

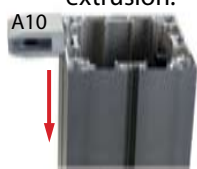

<p><b>Wing Attachment</b> Slide A10 Clamp into groove of square extrusion.</p> 	<p>When desired location is found, tighten set screw to secure.</p> 	<p>Tighten black plastic set screw to secure Wing in place.</p> 
--	---	---

**WHEN DISASSEMBLING ALUMINUM EXTRUSION, TIGHTEN ALL SETSCREWS AND LOCKS TO PREVENT LOSS DURING SHIPPING**

866.652.2100

Item	Qty.	Description
21	4	Shelf Support Extrusion

**Steps**

- 1) Attach shelf support extrusions [21] to assembled backwall as indicated.
- 2) Attach round signs to verticals using stand off barrels and caps.
- 3) Attach literature racks to verticals as shown.

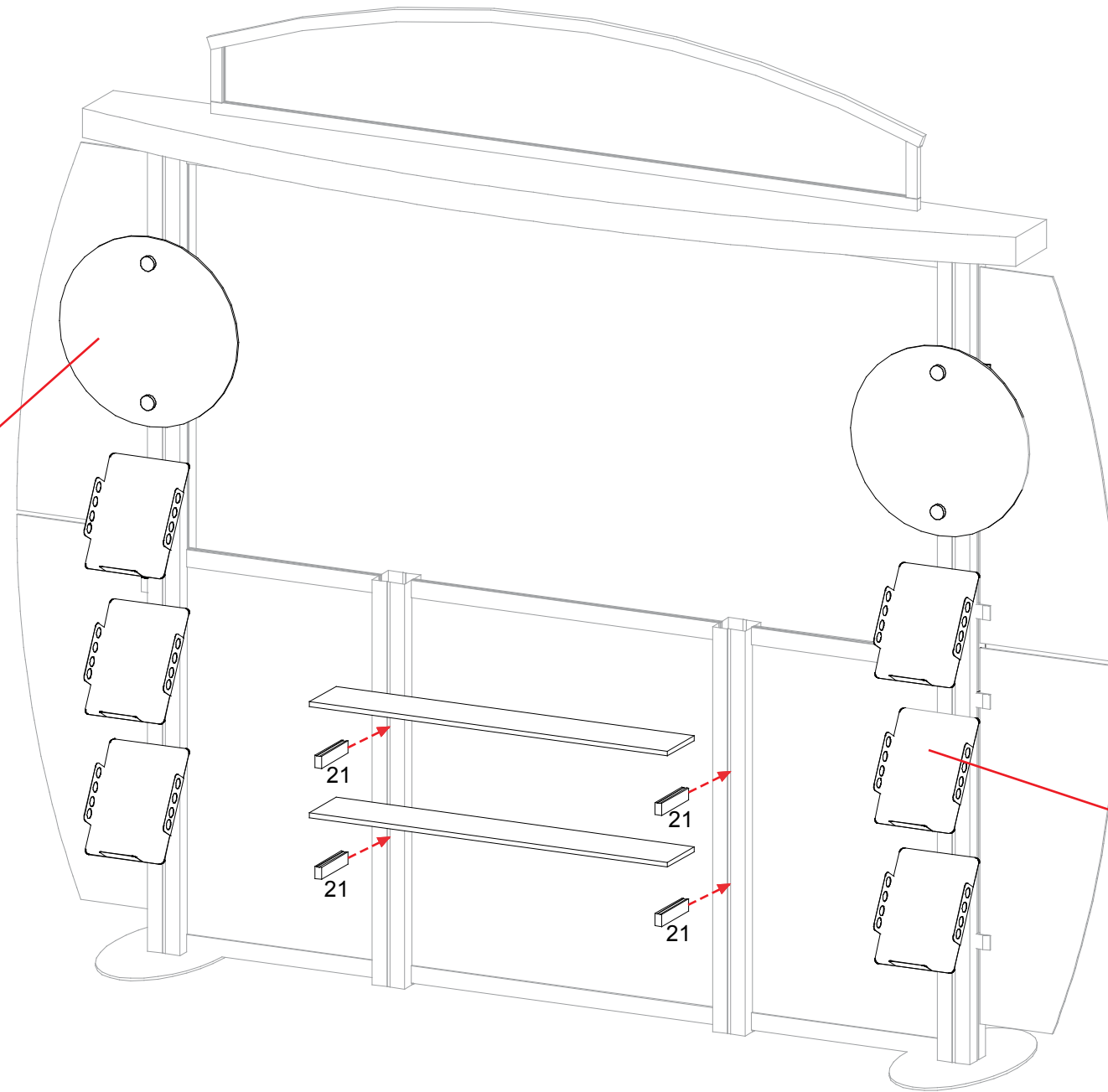
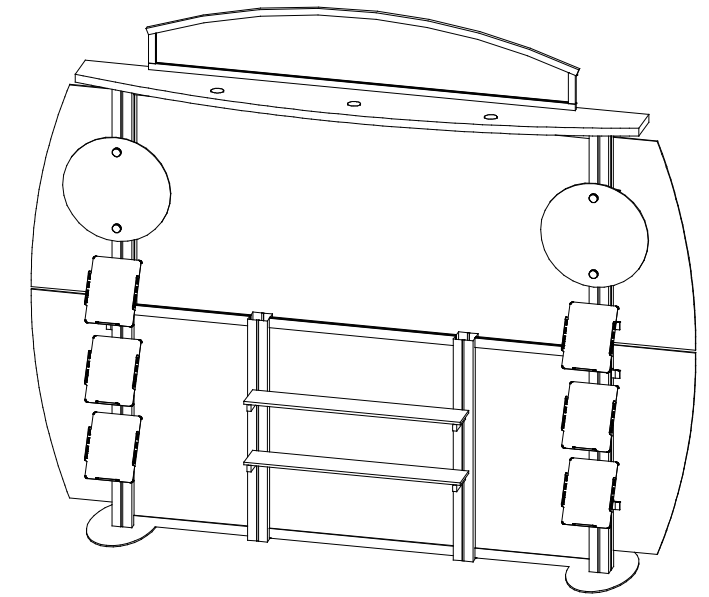

**Sign Attachment**

Slide stand off barrels into groove of backwall extrusion

Secure Sign to stand off barrels using stand off caps

**Literature Rack Attachment**

Tighten Lock to Secure

Attach connector piece to rack as shown. Then connect assembled literature rack to vertical extrusion.

**WHEN DISASSEMBLING ALUMINUM EXTRUSION, TIGHTEN ALL SETSCREWS AND LOCKS TO PREVENT LOSS DURING SHIPPING**

866.652.2100

Item	Qty.	Description
22	1	60"w Horizontal Extrusion w/ Velcro Attached
23	1	60"w Horizontal Extrusion w/ Velcro Attached
24	2	54"w Horizontal Extrusion
25	2	5.862"h Vertical Extrusion
26	2	5.862"h Vertical Extrusion
27	2	Curved Horizontal Extrusion
28	2	43.791" Vertical Extrusion
29	4	11.5" Horizontal Extrusion
30	2	29.835" Horizontal Extrusion
31	1	82.209" Vertical Extrusion
32	1	28.209" Vertical Extrusion

Steps:

- 1) Attach horizontal extrusions [22 and 23] between assembled backwalls as shown.
- 2) Attach horizontal extrusion [32] as shown below, then attach vertical [31] referring to Door attachment before completing.
- 3) Place door atop pins as shown in detail.
- 4) Attach horizontal extrusion [24] to top of ceiling using bolts supplied.
- 5) Attach vertical extrusions [26 and 27] atop horizontal extrusion [24] as shown.
- 6) Attach curved horizontal extrusion [27] atop vertical extrusions [25 and 26].
- 7) Attach ceiling with assembled frame atop upper horizontal [23] using screws and wing nuts and securing to other Ceiling.
- 8) Assemble extrusions [28, 29, and 30] as shown then attach between backwalls.
- 9) Place shelves as shown.
- 10) Repeat steps 4 - 7 for header.

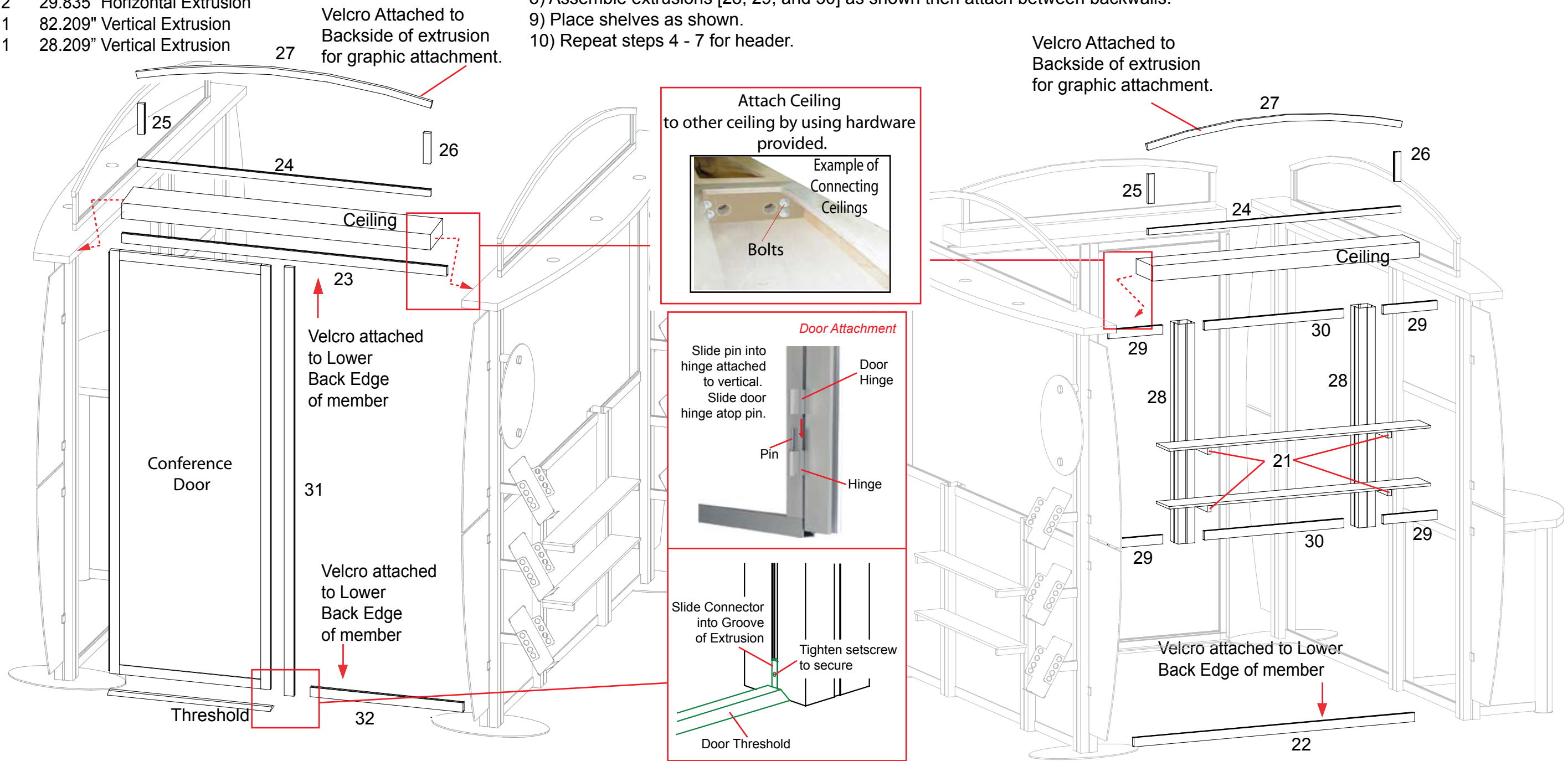

**WHEN DISASSEMBLING ALUMINUM EXTRUSION, TIGHTEN ALL SETSCREWS AND LOCKS TO PREVENT LOSS DURING SHIPPING**