

WHEN DISASSEMBLING ALUMINUM EXTRUSION, TIGHTEN ALL SETSCREWS AND LOCKS TO PREVENT LOSS DURING SHIPPING



## Using Your Setup Instructions

The Euro LT Hybrids Setup Instructions are created specifically for your configuration. They are laid out sequentially in levels, including exploded views, and a logical series of detailed steps to assemble the main structure and components. We encourage you to study the instructions **before** attempting to assemble your exhibit.

Each page reminds you to tighten the setscrews after disassembling your exhibit to prevent loss of the locks and setscrews (see below in RED). This is VERY IMPORTANT.

## Cleaning and Packing Your Display

- 1) Use care when cleaning aluminum extrusion or acrylic inserts. Use only non-abrasive cleaners.
- 2) When cleaning laminate inserts, countertops, or panels use mild cleansers and a soft material such as cotton.
- 3) Keep all display components away from extreme heat and long exposure to sunlight to avoid warping and fading.
- 4) Retain all packing material. It will make re-packing much easier and will reduce the likelihood of shipping damage.

## General Setup Instructions for Extrusion System



Most exhibits can be assembled with the supplied Hex Key Tool. Occasionally, a flat head screwdriver may be required.



Most horizontal extrusion connections have a patented expandable lock. This lock inserts into the groove of an opposing extrusion. Tightening the lock with the Hex Key Tool expands the lock and creates a strong positive connection.

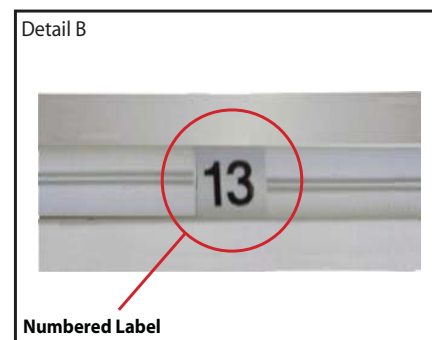

Each extrusion contains a numbered label which corresponds with setup instructions. The label is located within a groove of the extrusion (when possible). With extrusion components the labels contain Black numbers unless otherwise specified.



Remove only (1) setscrew when disassembling. Replace setscrew in extrusion after assembling it. Before packing, replace setscrew in extrusion to avoid losing it.

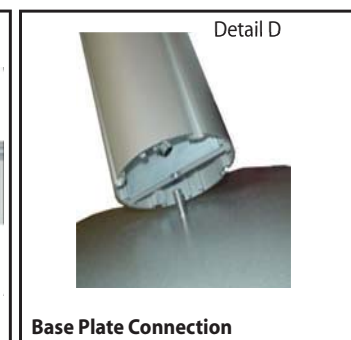

Attach base plate to round or square vertical extrusion using the bolt provided. Be careful not to strip the threads.

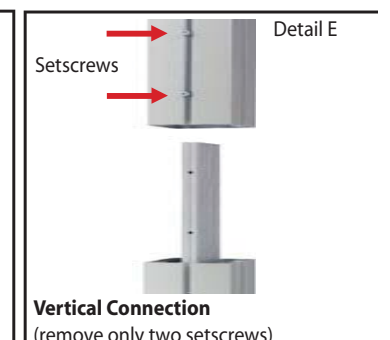

When vertical extrusions are packed in portable cases rather than crates or tubs, they must be broken down into smaller section which then require assembly.

Remove only (2) setscrews when disassembling. Replace setscrews in extrusion after assembling it. Before packing, replace setscrews in extrusion to avoid losing them.

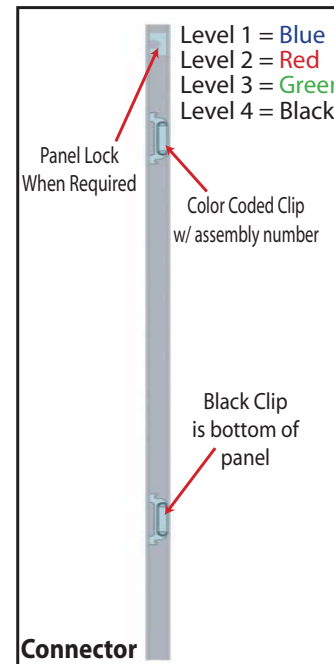

Each component has 2 clips, the lower clip is ALWAYS black. The top clip is color coded to distinguish which level. The color coded clip also contains the numbered label.

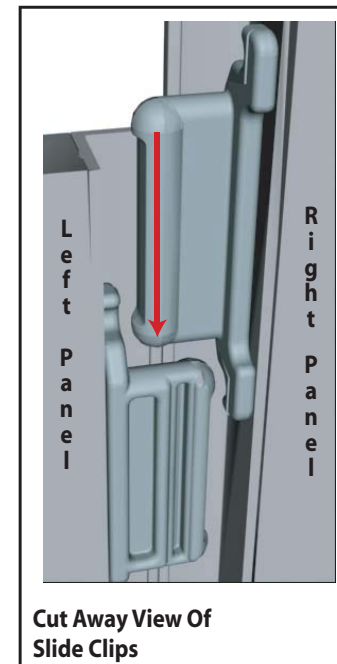

Components connect together by aligning them and sliding downward connecting clips together.

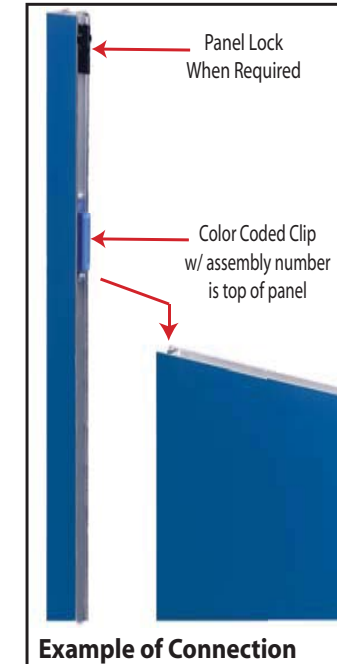

Configurations are assembled from left to right, usually starting with #1 and following the numbered sequence.

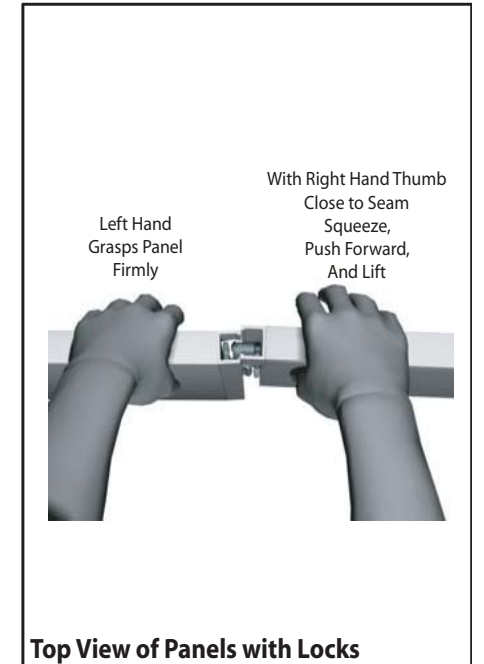

The first level of components contain panel locks that are located at the top of the panel for extra stability and seamless connection. When disassembling panels twist top connection slightly and lift right panel upward.

**WHEN DISASSEMBLING ALUMINUM EXTRUSION, TIGHTEN ALL SETSCREWS AND LOCKS TO PREVENT LOSS DURING SHIPPING**

Item	Qty.	Description
1/1a/1b	1/1/1	Base Plate
2a/2b	1/1	48" h Vertical Extrusion
3	1	79.7982" h Vertical Extrusion
4a/4b	1/1	48" h Vertical Extrusion
5	1	82.72" h Vertical Extrusion
6a/6b	1/1	48.0185" w Horizontal Extrusion
7a/7b	1/1	49.2385" w Horizontal Extrusion
8a/8b	1/1	43.087" w Horizontal Extrusion
9a/9b	1/1	43.01" w Horizontal Extrusion
10a/10b	1/1	44.4215" w Horizontal Extrusion
11a/11b	1/1	45.1683" w Horizontal Extrusion
12	2	8.039" w Horizontal Extrusion

- Steps:
- 1) Connect vertical extrusions [2a to 2b and 4a to 4b] together.
  - 2) Attach vertical extrusions [2a/2b, 3, 4a/4b and 5] to base plates [1, 1a and 1b], see detail D on general info. page.
  - 3) Connect horizontal extrusions [6a to 6b, 7a to 7b, 8a to 8b, 9a to 9b, 10a to 10b and 11a to 11b].
  - 4) Attach horizontal assemblies between vertical extrusions.
  - 5) Apply graphics to assembled backwall as shown.

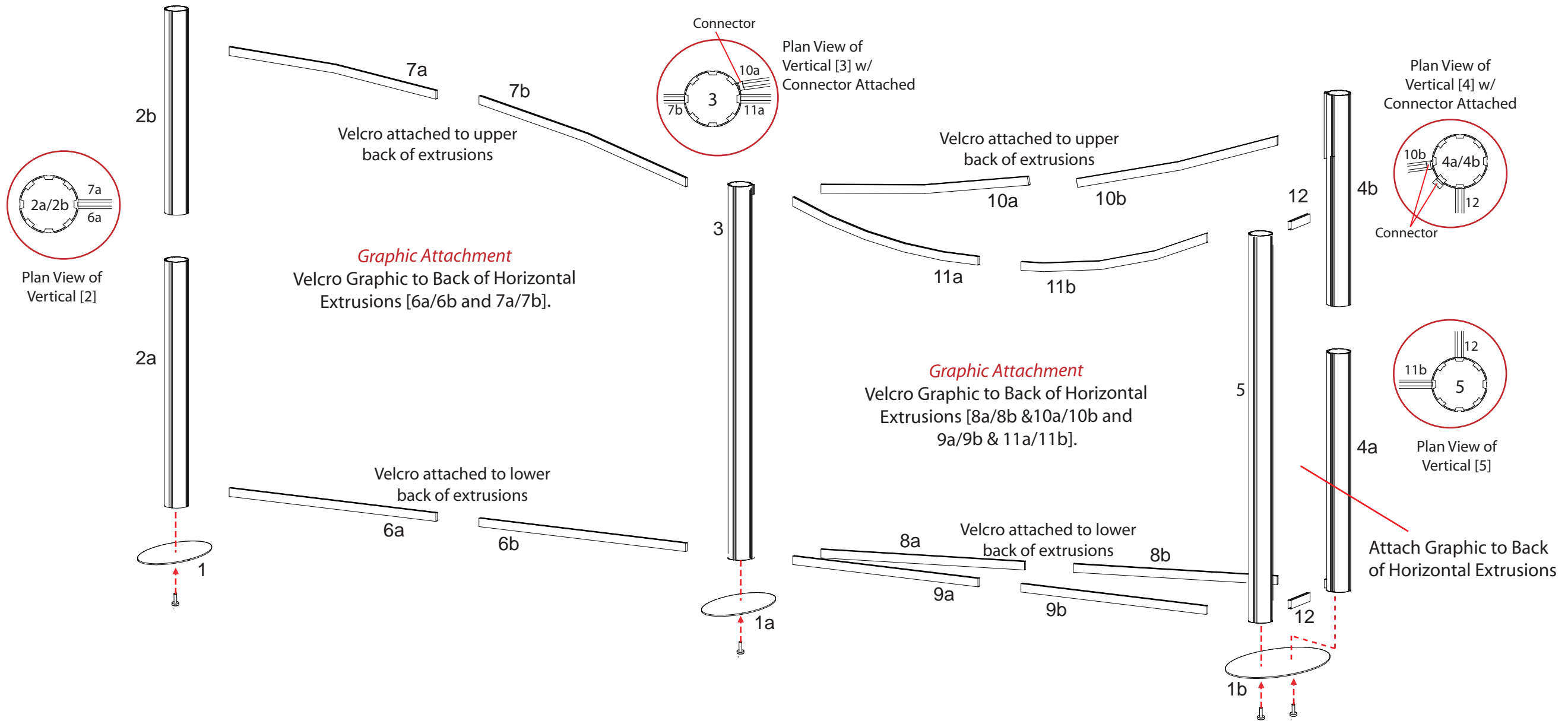
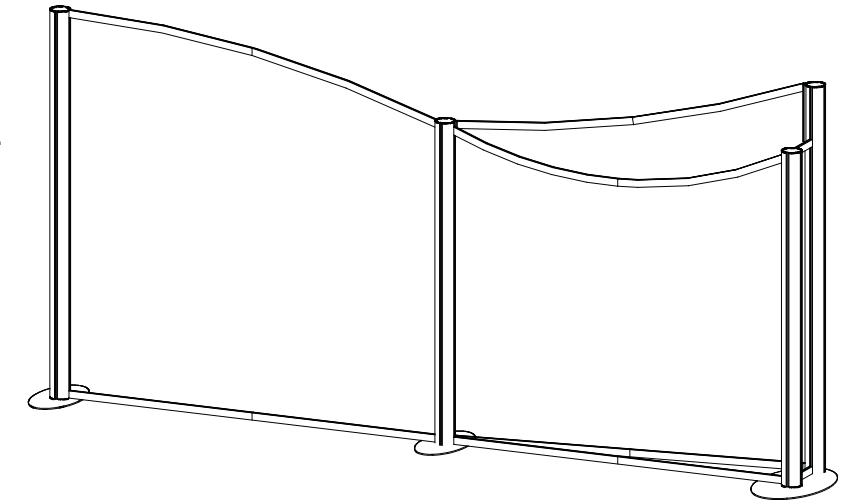

**WHEN DISASSEMBLING ALUMINUM EXTRUSION, TIGHTEN ALL SETSCREWS AND LOCKS TO PREVENT LOSS DURING SHIPPING**

866.652.2100

Item	Qty.	Description
1c	1	Base Plate
13a	1	Support Leg Left
13b	1	Support Leg Right
14	1	Shelf Support
15a/15b	1/1	48"h Vertical Extrusion
16a/16b	1/1	46.25"w Horizontal Extrusion
17a/17b	1/1	46.25"w Horizontal Extrusion

- Steps:
- 1) Attach vertical extrusions [15a to 15b] together.
  - 2) Attach vertical assembly [15a/15b] and support legs [13a and 13b] to base plate [1c].
  - 3) Attach shelf support [14] between support legs [13a and 13b], then set shelf atop support with notched side fitting to vertical extrusion and secure with thumbscrews to vertical extrusion [15].
  - 4) Connect horizontal extrusions together [16a to 16b and 17a to 17b].
  - 5) Attach horizontal assemblies between vertical extrusions [4 and 15], placing inserts as shown.
  - 6) Attach wings to vertical extrusions [2 and 4], see wing attachment detail.

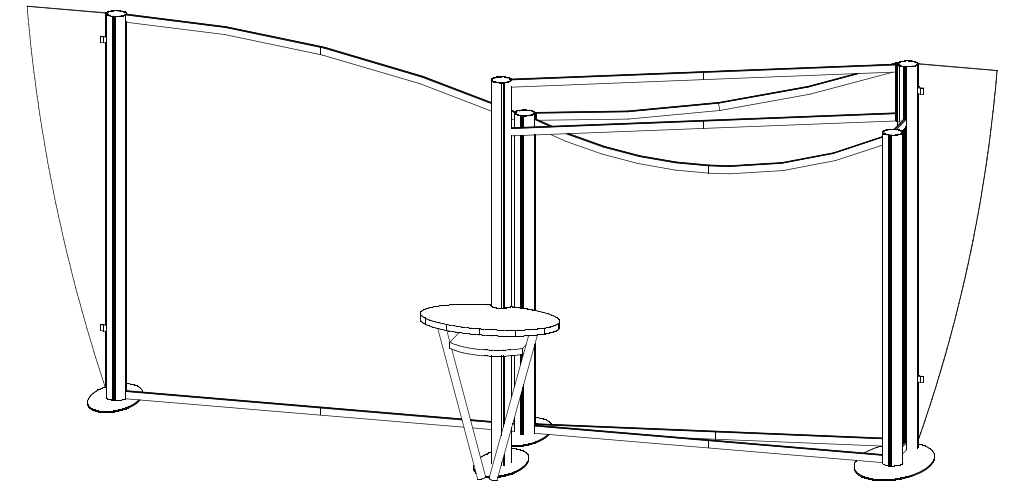

**Wing Attachment**

Slide A10 Clamp into groove of square extrusion.



When desired location is found, tighten set screw to secure.

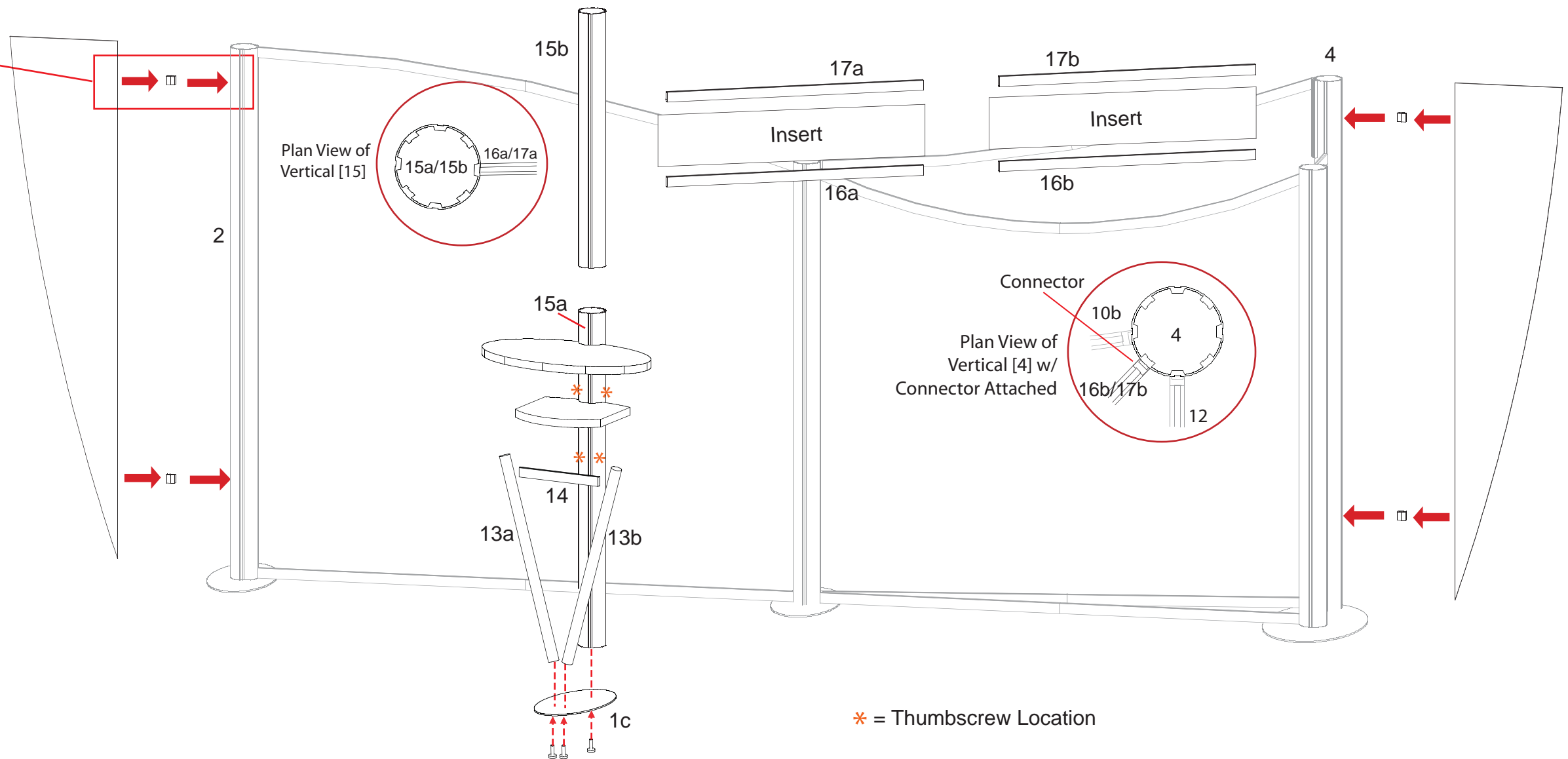

Tighten black plastic set screw to secure Wing in place.

**WHEN DISASSEMBLING ALUMINUM EXTRUSION, TIGHTEN ALL SETSCREWS AND LOCKS TO PREVENT LOSS DURING SHIPPING**

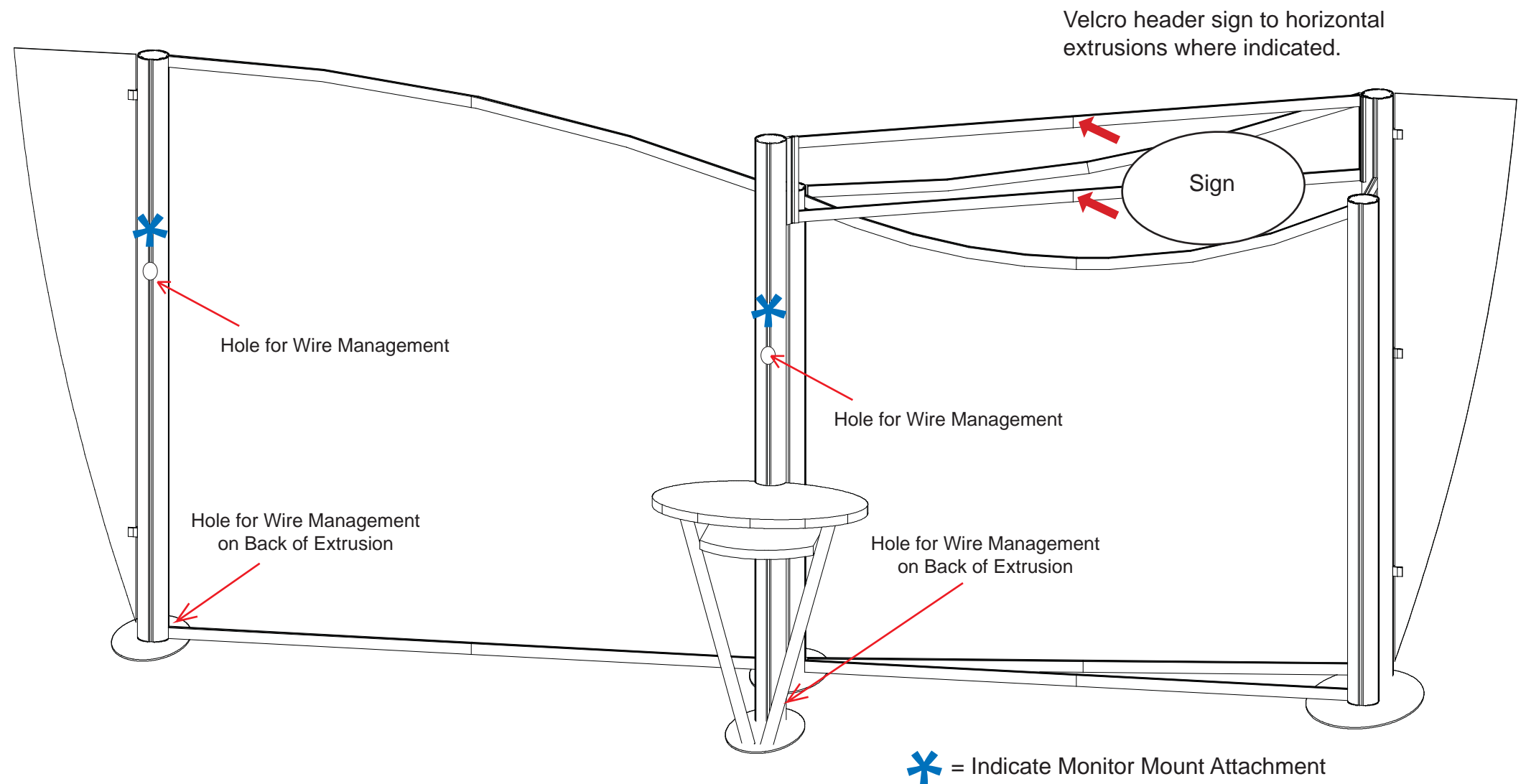
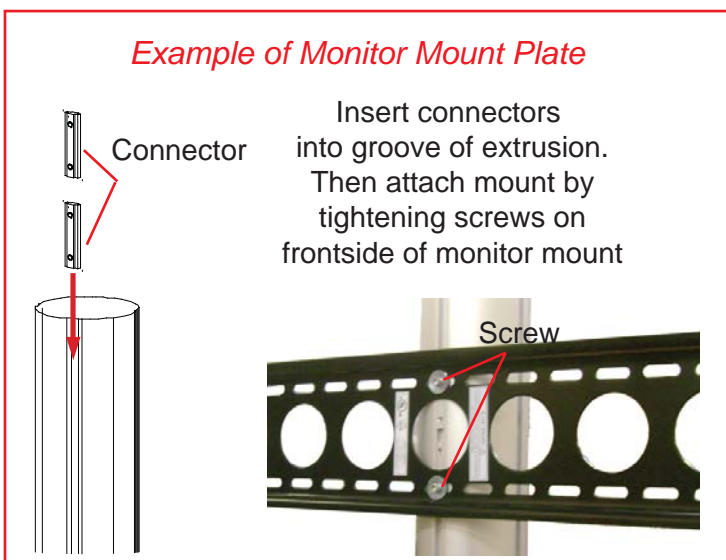
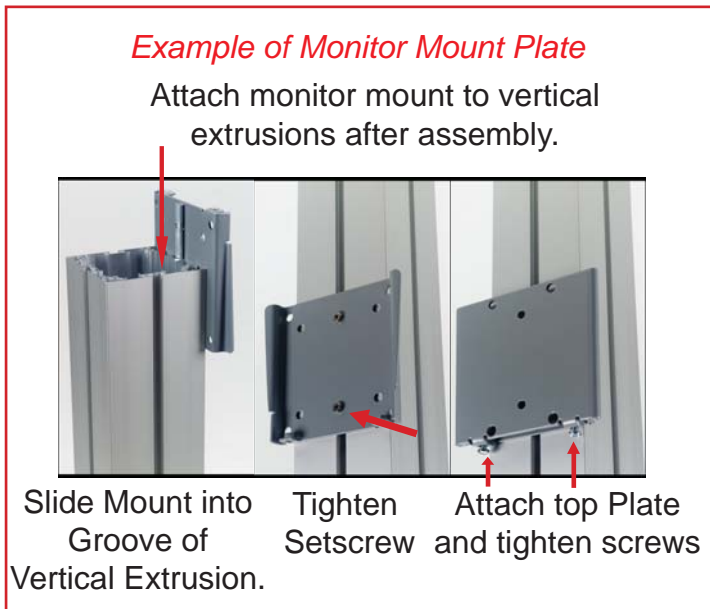
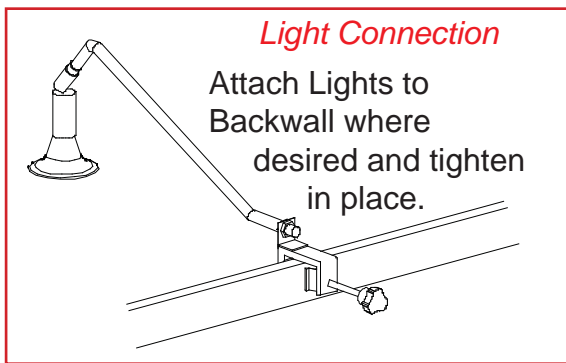

WHEN DISASSEMBLING ALUMINUM EXTRUSION, TIGHTEN ALL SETSCREWS AND LOCKS TO PREVENT LOSS DURING SHIPPING

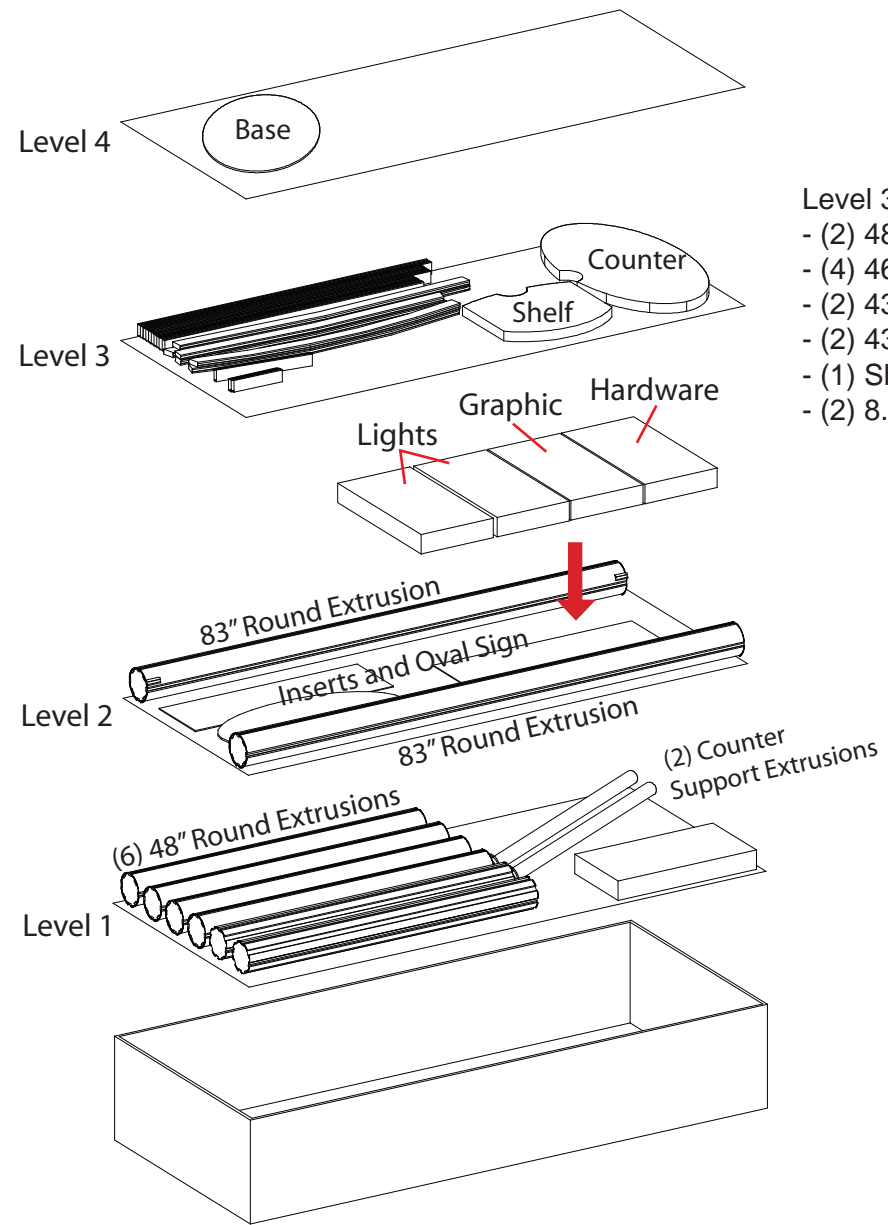

Level 3: Part List

- (2) 48.0185" Extrusion
- (4) 46.25" Extrusion
- (2) 43.087" Extrusion
- (2) 43.01" Extrusion
- (1) Shelf Support Extrusion
- (2) 8.039" Extrusion



WHEN DISASSEMBLING ALUMINUM EXTRUSION, TIGHTEN ALL SETSCREWS AND LOCKS TO PREVENT LOSS DURING SHIPPING