

Part Number	Qty for Step	Description
1/1A	1/1	42" h Vertical Extrusion
2	1	42" h Vertical Extrusion w/ Door Stop
3	1	40.5" h Vertical Extrusion w/ Door Hinges
4	1	20.09" w Curved Horizontal Extrusion
5	1	20.09" w Curved Horizontal Extrusion
6	1	20.09" w Curved Horizontal Extrusion
7	1	20.09" w Curved Horizontal Extrusion
8	1	20.09" w Curved Horizontal Extrusion
9	1	20.09" w Curved Horizontal Extrusion
10	1	20.09" w Curved Horizontal Extrusion
11	1	20.09" w Curved Horizontal Extrusion

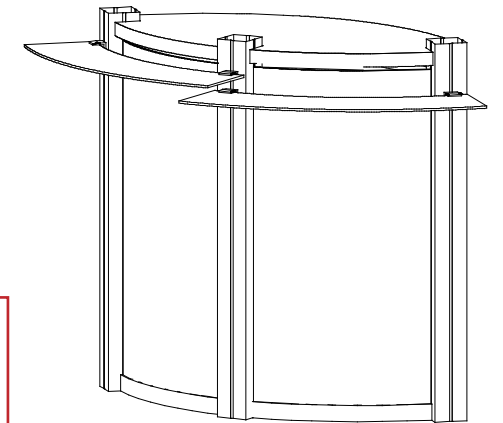

**Steps:**

- 1) Connect horizontal extrusions [4, 5, 6 and 7] between vertical extrusions [1, 1A, 2 and 3] where indicated.
- 2) Place inserts and attach door where indicated.
- 3) Connect upper horizontal extrusions [8, 9, 10 and 11] between vertical extrusions [1, 1A, 2 and 3].
- 4) Velcro internal shelf supports to inside of assembled base.
- 5) Set internal shelf and counter top as shown.
- 6) Attach Plex shelves to pedestal using A10 clamps, see Shelf Attachment details.

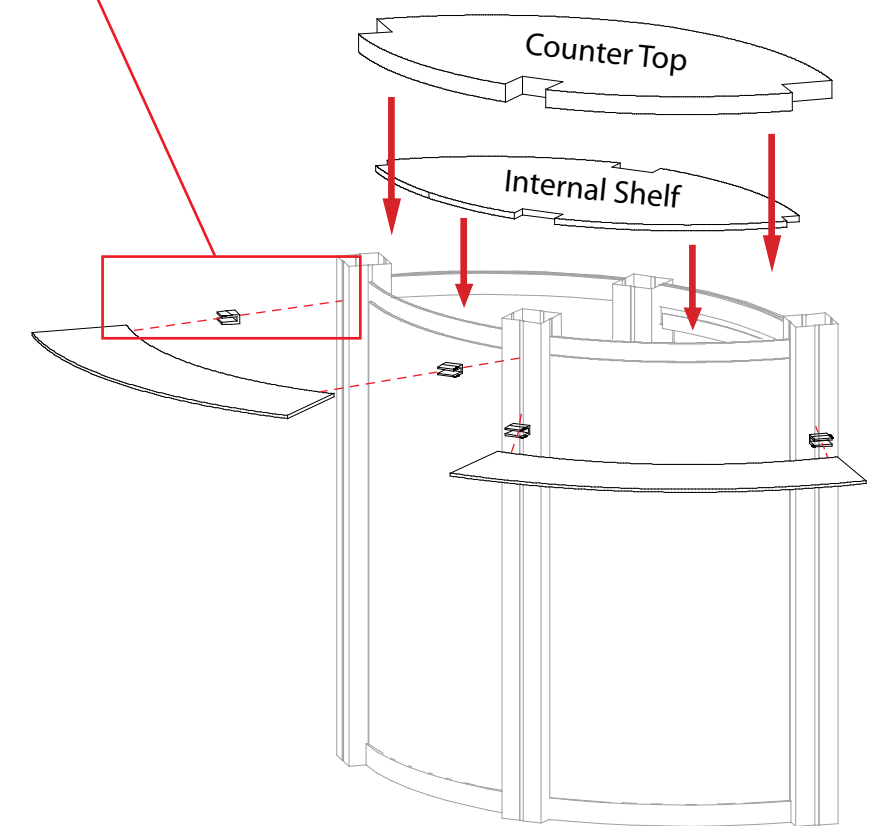
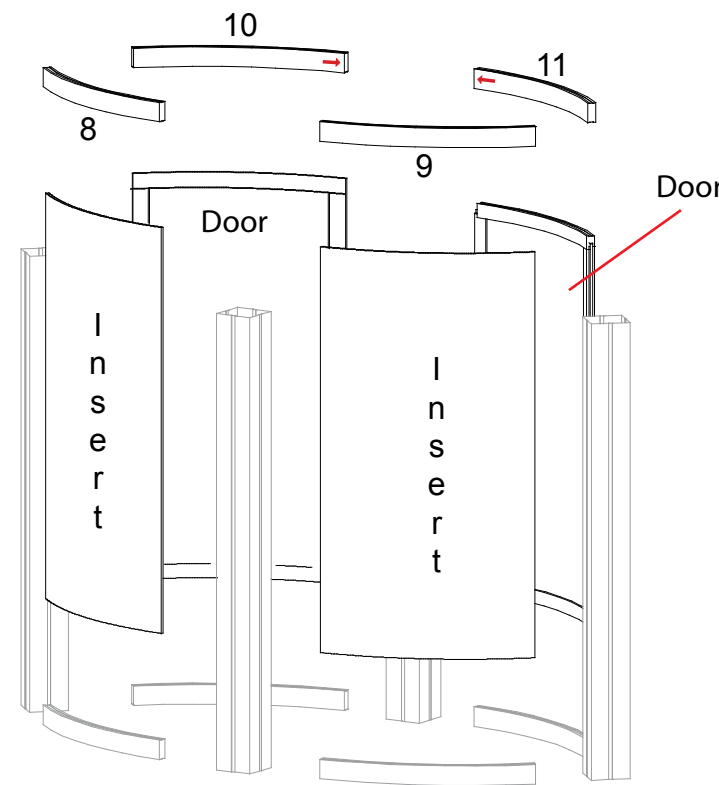
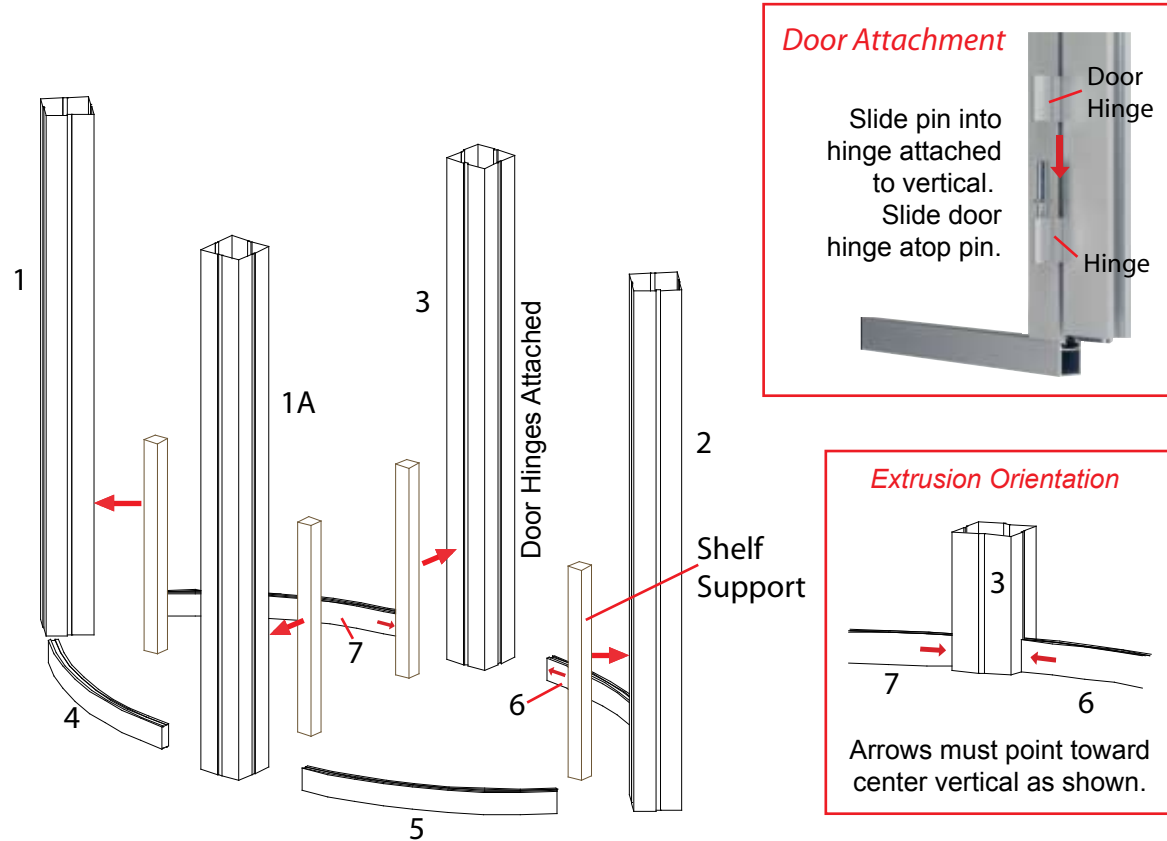
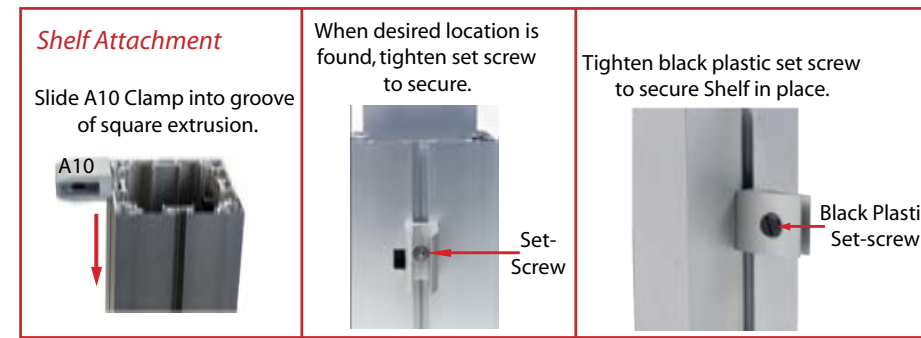

**WHEN DISASSEMBLING ALUMINUM EXTRUSION, TIGHTEN ALL SETSCREWS AND LOCKS TO PREVENT LOSS DURING SHIPPING**

# visionary™ IDESIGNS

## Using Your Setup Instructions

The Visionary Designs Setup Instructions are created specifically for your configuration. They are laid out sequentially, including an exploded view of the entire display, and then a logical series of detailed steps to assemble the main structure and components. We encourage you to study the instructions **before** attempting to assemble your exhibit.

Each page reminds you to tighten the setscrews after disassembling your exhibit to prevent loss of the locks and setscrews (see below in RED). This is VERY IMPORTANT.

## Cleaning and Packing Your Display

- 1) Use care when cleaning aluminum extrusion or acrylic inserts. Use only non-abrasive cleaners.
- 2) When cleaning laminate inserts or countertops, use mild cleansers and a soft material such as cotton.
- 3) Keep all display components away from extreme heat and long exposure to sunlight to avoid warping and fading.
- 4) Retain all packing material. It will make re-packing much easier and will reduce the likelihood of shipping damage.



The Tool

Most Visionary Designs exhibits can be assembled with the supplied Hex Key Tool. Occasionally, a flat head screwdriver may be required.



Detail A

Typical Connection



Typical Connection (cont'd)

Most horizontal extrusion connections have a patented expandable lock. This lock inserts into the groove of an opposing extrusion. Tightening the lock with the Hex Key Tool expands the lock and creates a strong positive connection.

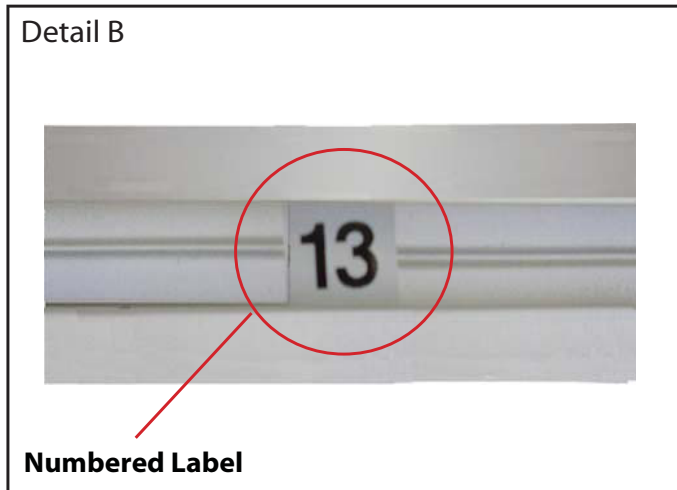

Detail B

Numbered Label

Each extrusion contains a numbered label which corresponds with setup instructions. The label is located within a groove of the extrusion (when possible). With Visionary Designs the labels contain Black numbers unless otherwise specified.



Detail C

Horizontal Inline Connection (remove only one setscrew)

Remove only (1) setscrew when disassembling. Replace setscrew in extrusion after assembling it. Before packing, replace setscrew in extrusion to avoid losing it.

**NOTE :**

PDF copies of your Setup Instructions are available @ [www.classicexhibits.com](http://www.classicexhibits.com)  
 Use the Search Tool located on the lower left-hand corner of the Classic Home  
 Enter your 5-7 digit Order #.

Search for Setup Instructions

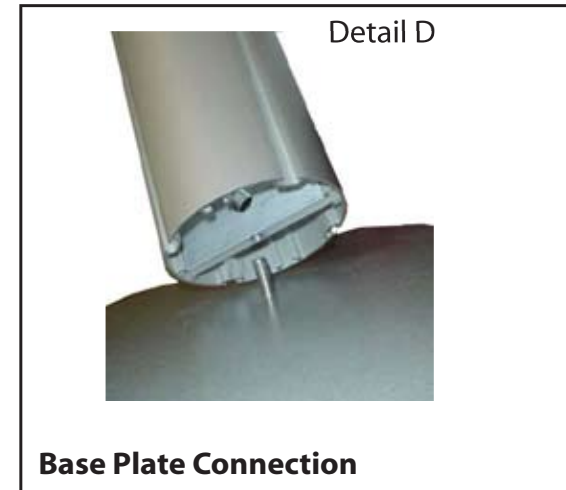

Detail D

Base Plate Connection

Attach base plate to round or square vertical extrusion using the bolt provided. Be careful not to strip the threads.

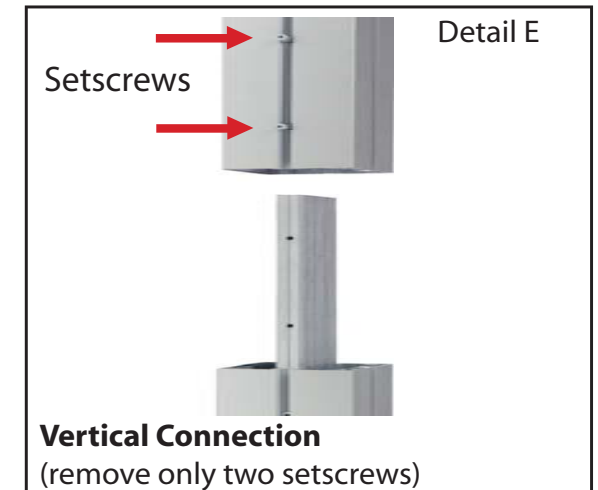

Detail E

Vertical Connection (remove only two setscrews)

When vertical extrusions are packed in portable cases rather than crates or tubs, they must be broken down into smaller sections which then require assembly.

Remove only (2) setscrews when disassembling. Replace setscrews in extrusion after assembling it. Before packing, replace setscrews in extrusion to avoid losing them.

**WHEN DISASSEMBLING ALUMINUM EXTRUSION, TIGHTEN ALL SETSCREWS AND LOCKS TO PREVENT LOSS DURING SHIPPING**

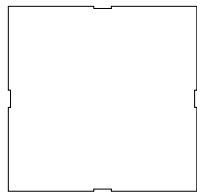

42" Square Extrusion  
Qty. : 3

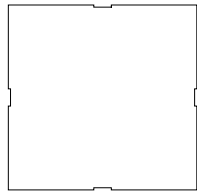

40.5" Square Extrusion  
Qty. : 1

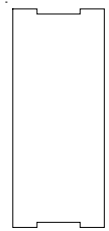

20.09" Curved Horizontal Extrusion  
Qty. : 8

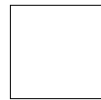

Internal Shelf Support  
Qty. : 4

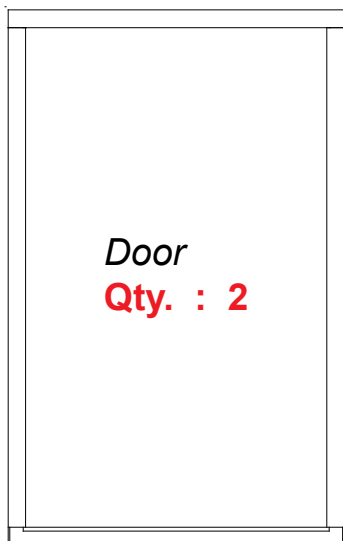

Door  
Qty. : 2

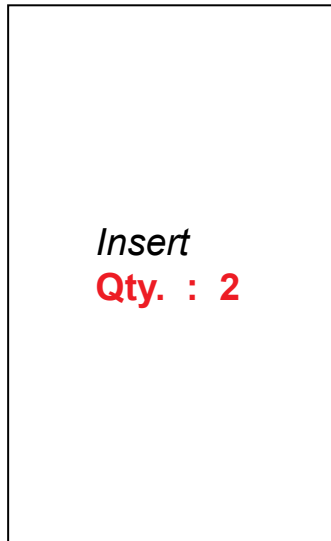

Insert  
Qty. : 2

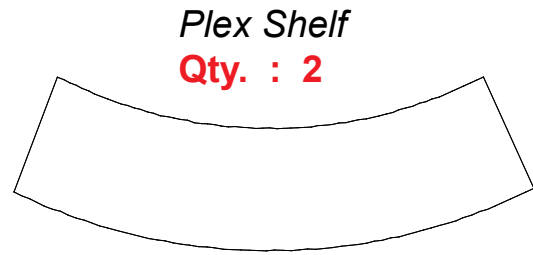

Plex Shelf  
Qty. : 2

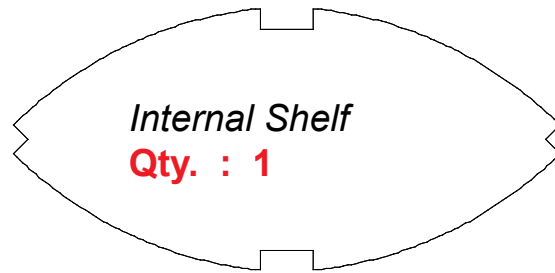

Internal Shelf  
Qty. : 1

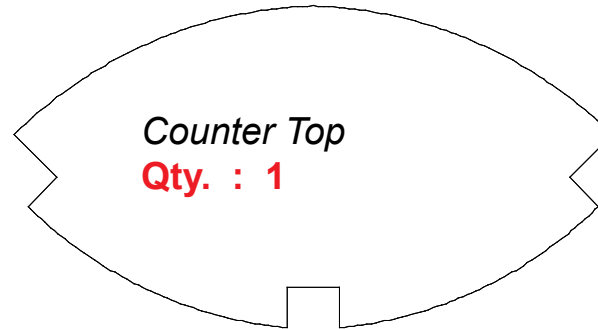

Counter Top  
Qty. : 1

Additional Accessories:

Setup Hardware

(4) A10 Clamps

Four horizontal lines for additional accessories.

WHEN DISASSEMBLING ALUMINUM EXTRUSION, TIGHTEN ALL SETSCREWS AND LOCKS TO PREVENT LOSS DURING SHIPPING

Part Number	Qty for Step	Description
1/1A	1/1	42" h Vertical Extrusion
2	1	42" h Vertical Extrusion w/ Door Stop
3	1	40.5" h Vertical Extrusion w/ Door Hinges
4	1	20.09" w Curved Horizontal Extrusion
5	1	20.09" w Curved Horizontal Extrusion
6	1	20.09" w Curved Horizontal Extrusion
7	1	20.09" w Curved Horizontal Extrusion
8	1	20.09" w Curved Horizontal Extrusion
9	1	20.09" w Curved Horizontal Extrusion
10	1	20.09" w Curved Horizontal Extrusion
11	1	20.09" w Curved Horizontal Extrusion

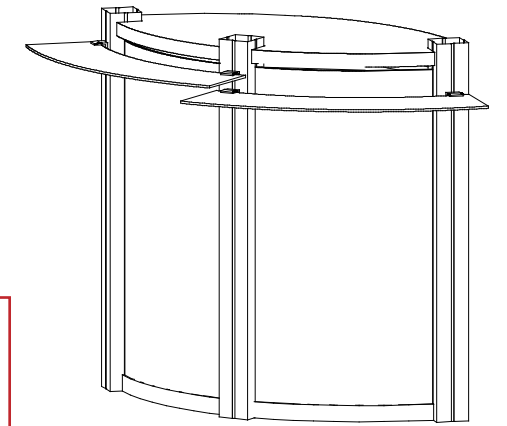

**Steps:**

- 1) Connect horizontal extrusions [4, 5, 6 and 7] between vertical extrusions [1, 1A, 2 and 3] where indicated.
- 2) Place inserts and attach door where indicated.
- 3) Connect upper horizontal extrusions [8, 9, 10 and 11] between vertical extrusions [1, 1A, 2 and 3].
- 4) Velcro internal shelf supports to inside of assembled base.
- 5) Set internal shelf and counter top as shown.
- 6) Attach Plex shelves to pedestal using A10 clamps, see Shelf Attachment details.

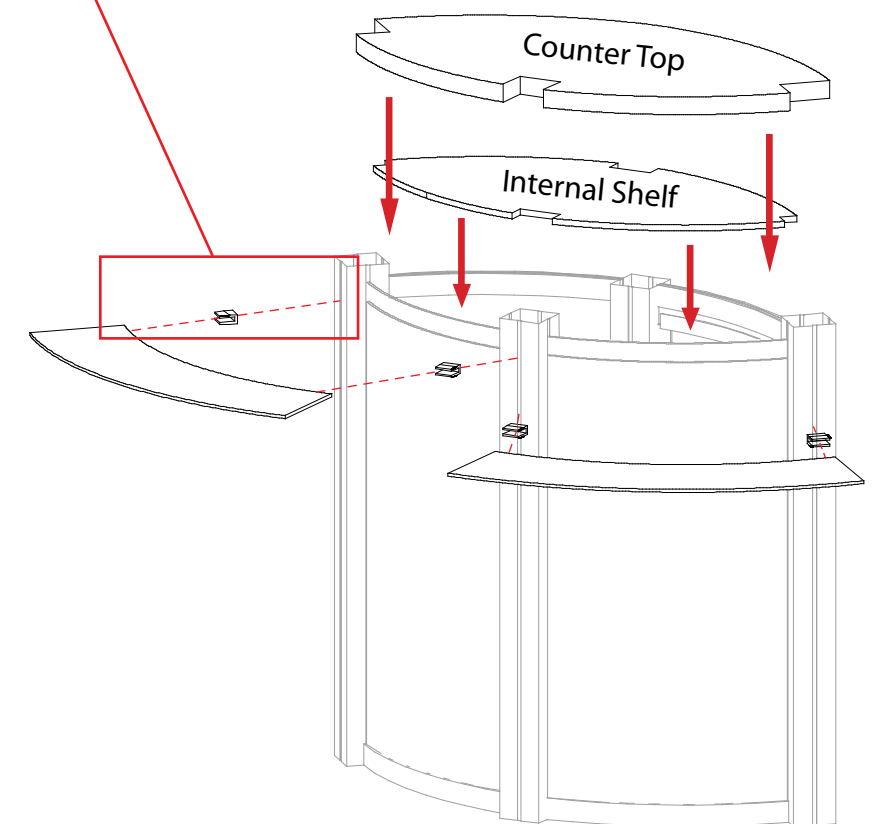
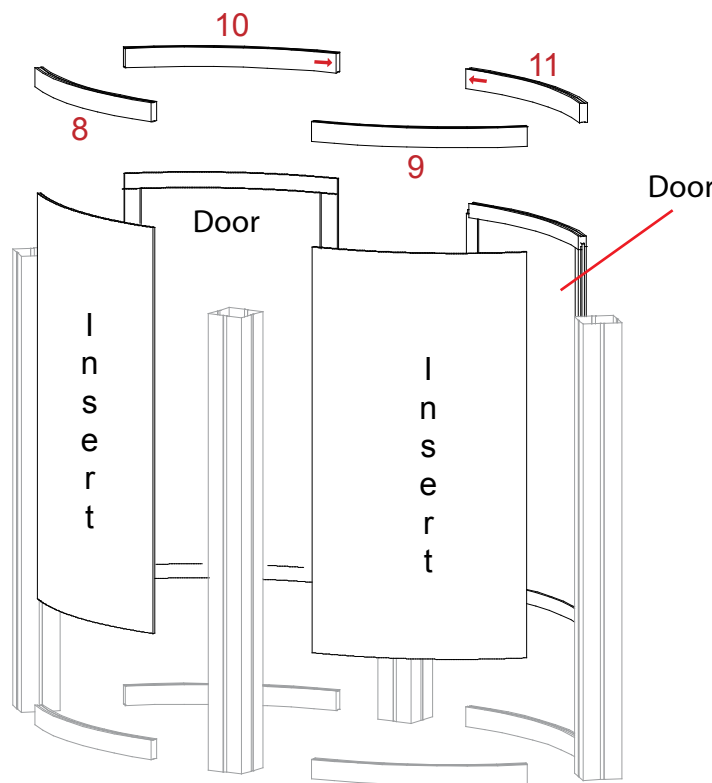
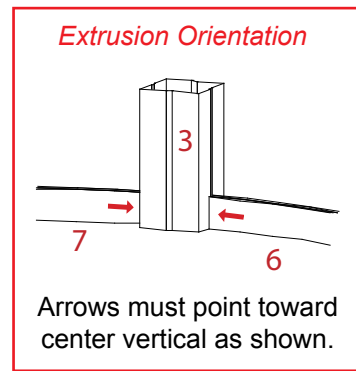
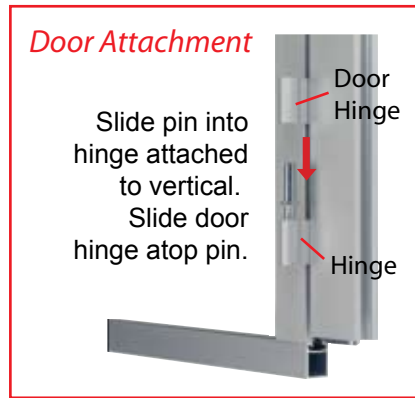
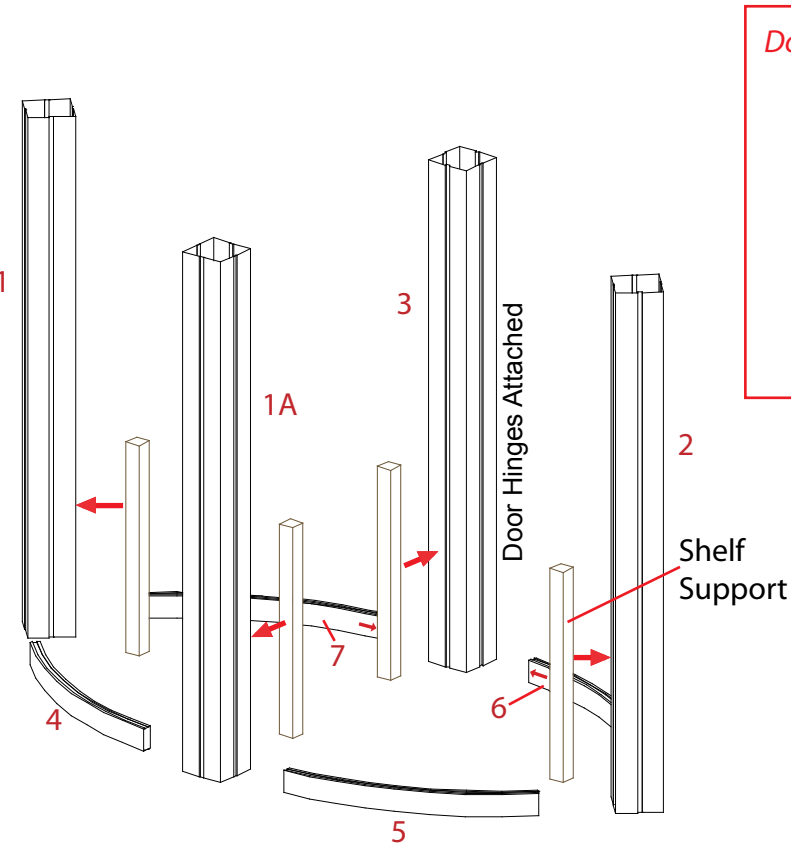
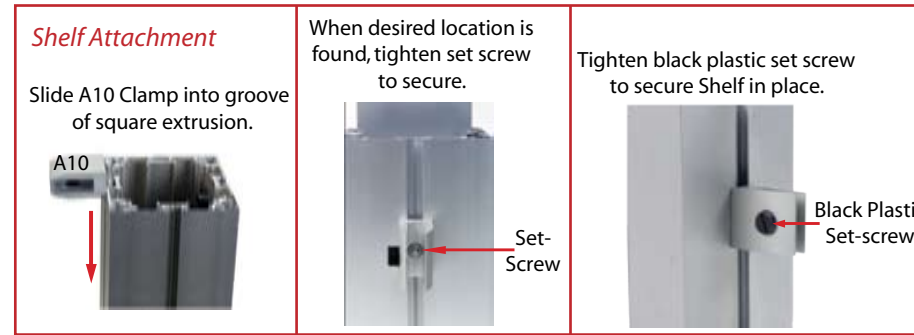

**WHEN DISASSEMBLING ALUMINUM EXTRUSION, TIGHTEN ALL SETSCREWS AND LOCKS TO PREVENT LOSS DURING SHIPPING**

# visionary™ IDESIGNS

## Using Your Setup Instructions

The Visionary Designs Setup Instructions are created specifically for your configuration. They are laid out sequentially, including an exploded view of the entire display, and then a logical series of detailed steps to assemble the main structure and components. We encourage you to study the instructions **before** attempting to assemble your exhibit.

Each page reminds you to tighten the setscrews after disassembling your exhibit to prevent loss of the locks and setscrews (see below in RED). This is **VERY IMPORTANT**.

## Cleaning and Packing Your Display

- 1) Use care when cleaning aluminum extrusion or acrylic inserts. Use only non-abrasive cleaners.
- 2) When cleaning laminate inserts or countertops, use mild cleansers and a soft material such as cotton.
- 3) Keep all display components away from extreme heat and long exposure to sunlight to avoid warping and fading.
- 4) Retain all packing material. It will make re-packing much easier and will reduce the likelihood of shipping damage.



**The Tool**

Most Visionary Designs exhibits can be assembled with the supplied Hex Key Tool. Occasionally, a flat head screwdriver may be required.



**Typical Connection**

Most horizontal extrusion connections have a patented expandable lock. This lock inserts into the groove of an opposing extrusion. Tightening the lock with the Hex Key Tool expands the lock and creates a strong positive connection.



**Typical Connection (cont'd)**

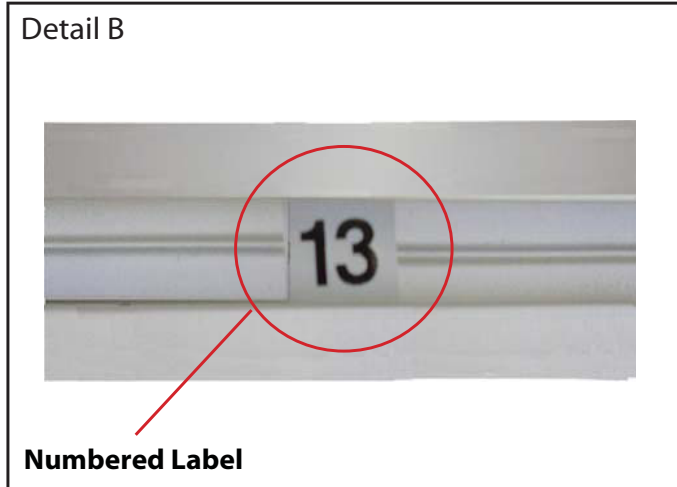

**Numbered Label**

Each extrusion contains a numbered label which corresponds with setup instructions. The label is located within a groove of the extrusion (when possible). With Visionary Designs the labels contain Black numbers unless otherwise specified.



**Horizontal Inline Connection** (remove only one setscrew)

Remove only (1) setscrew when disassembling. Replace setscrew in extrusion after assembling it. Before packing, replace setscrew in extrusion to avoid losing it.

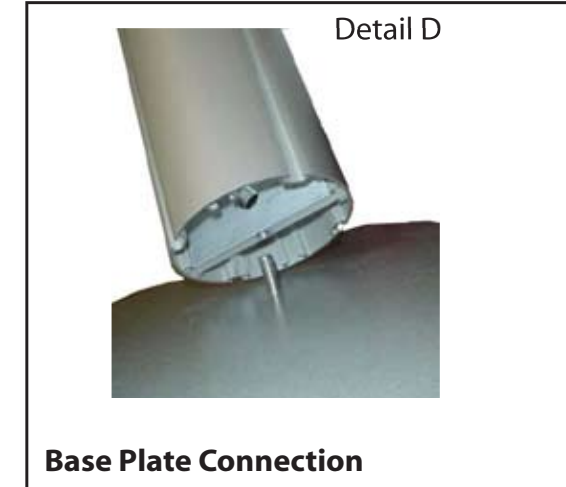

**Base Plate Connection**

Attach base plate to round or square vertical extrusion using the bolt provided. Be careful not to strip the threads.

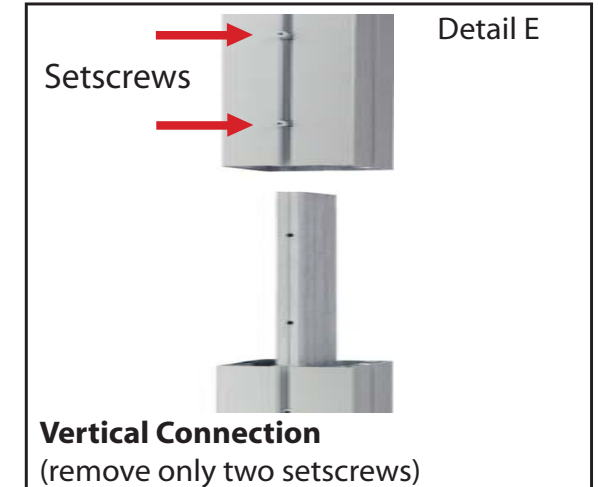

**Vertical Connection**  
(remove only two setscrews)

When vertical extrusions are packed in portable cases rather than crates or tubs, they must be broken down into smaller sections which then require assembly.

Remove only (2) setscrews when disassembling. Replace setscrews in extrusion after assembling it. Before packing, replace setscrews in extrusion to avoid losing them.

**NOTE :**

PDF copies of your Setup Instructions are available @ [www.classicexhibits.com](http://www.classicexhibits.com)  
Use the Search Tool located on the lower left-hand corner of the Classic Home  
Enter your 5-7 digit Order #.

Search for Setup Instructions

**WHEN DISASSEMBLING ALUMINUM EXTRUSION, TIGHTEN ALL SETSCREWS AND LOCKS TO PREVENT LOSS DURING SHIPPING**

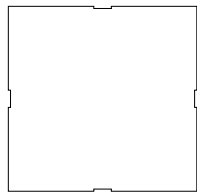

42" Square Extrusion  
Qty. : 3

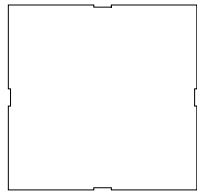

40.5" Square Extrusion  
Qty. : 1

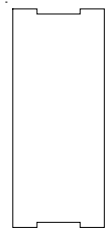

20.09" Curved Horizontal Extrusion  
Qty. : 8

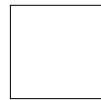

Internal Shelf Support  
Qty. : 4

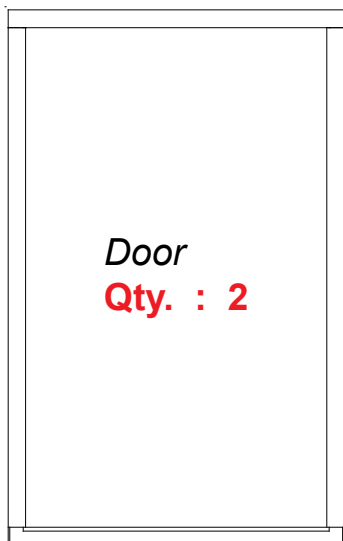

Door  
Qty. : 2

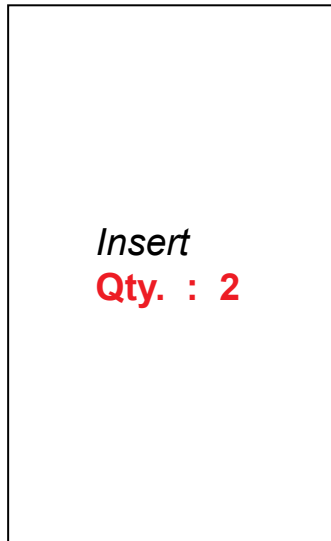

Insert  
Qty. : 2

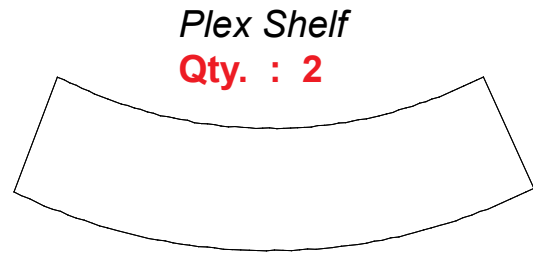

Plex Shelf  
Qty. : 2

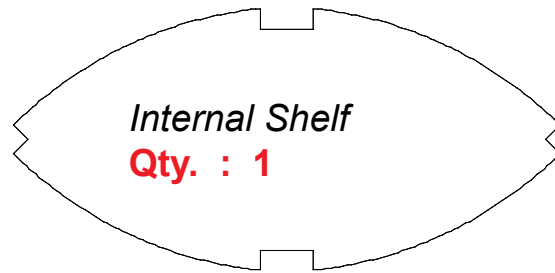

Internal Shelf  
Qty. : 1

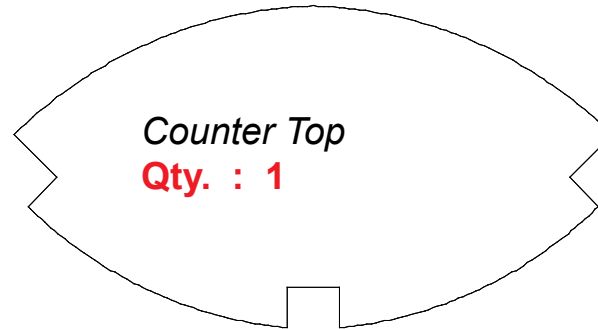

Counter Top  
Qty. : 1

Additional Accessories:

Setup Hardware

(4) A10 Clamps

Four horizontal lines for additional accessories.

WHEN DISASSEMBLING ALUMINUM EXTRUSION, TIGHTEN ALL SETSCREWS AND LOCKS TO PREVENT LOSS DURING SHIPPING



Part Number	Qty for Step	Description
12/12A	1/1	42" h Vertical Extrusion
13	1	42" h Vertical Extrusion w/ Door Stop
14	1	40.5" h Vertical Extrusion w/ Door Hinges
15	1	20.09" w Curved Horizontal Extrusion
16	1	20.09" w Curved Horizontal Extrusion
17	1	20.09" w Curved Horizontal Extrusion
18	1	20.09" w Curved Horizontal Extrusion
19	1	20.09" w Curved Horizontal Extrusion
20	1	20.09" w Curved Horizontal Extrusion
21	1	20.09" w Curved Horizontal Extrusion
22	1	20.09" w Curved Horizontal Extrusion
23	1	26.875" h Square Vertical Extrusion
24	1	26.875" h Square Vertical Extrusion

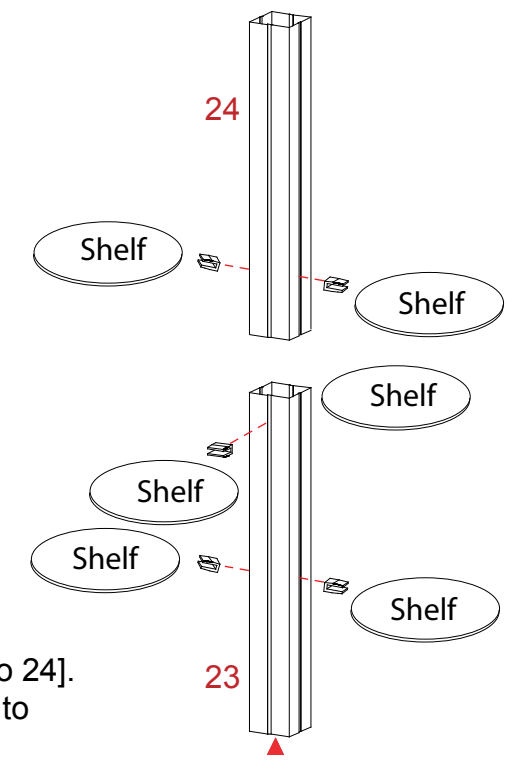
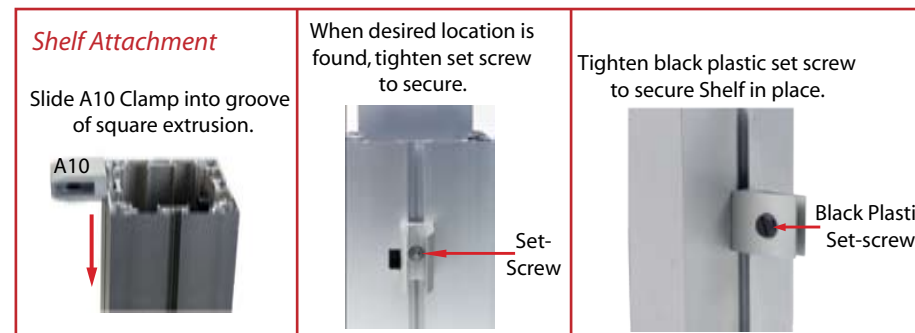

**Steps:**

- 1) Connect horizontal extrusions [15, 16, 17 and 18] between vertical extrusions [12, 12A, 13 and 14] where indicated.
- 2) Place inserts and attach door where indicated.
- 3) Connect upper horizontal extrusions [19, 20, 21 and 22] between vertical extrusions [12, 12A, 13 and 14].
- 4) Velcro internal shelf supports to inside of assembled base.
- 5) Set internal shelf and counter top as shown.
- 6) Attach Plex shelves to pedestal using A10 clamps, see Shelf Attachment details.

**Steps:**

- 7) Connect square extrusions [23 to 24].
- 8) Attach vertical assembly [23/24] to counter top using provided bolt.

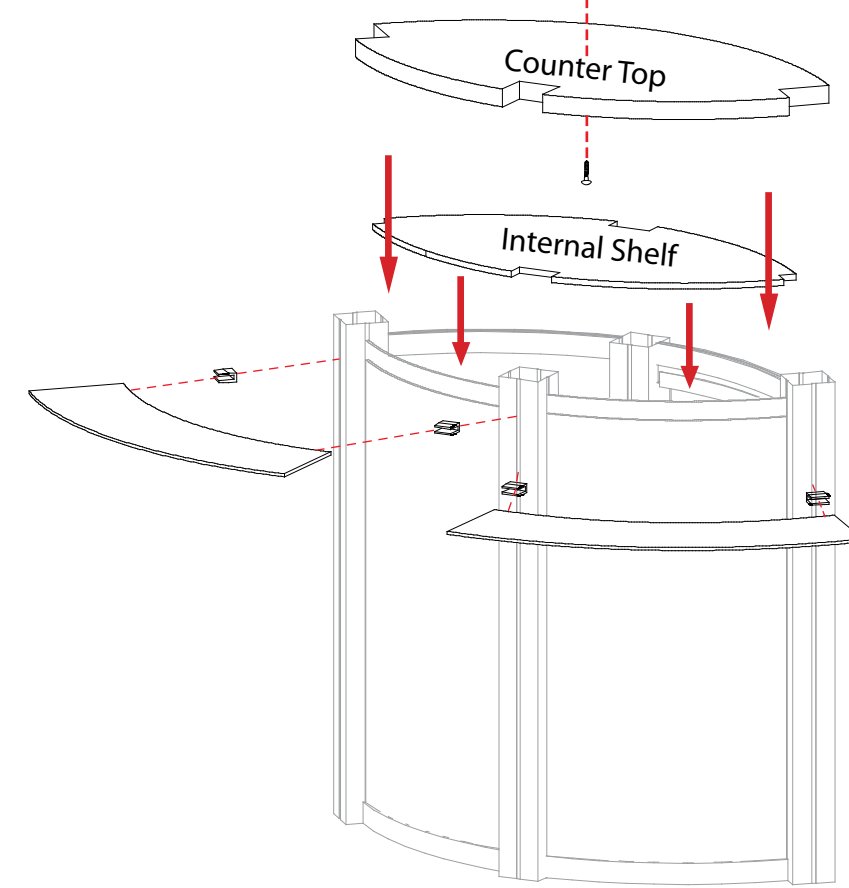
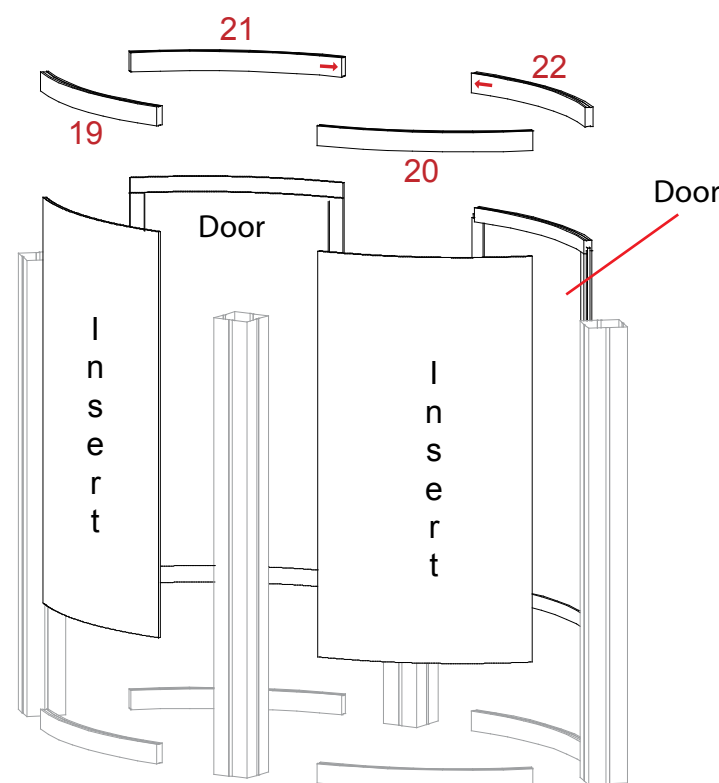
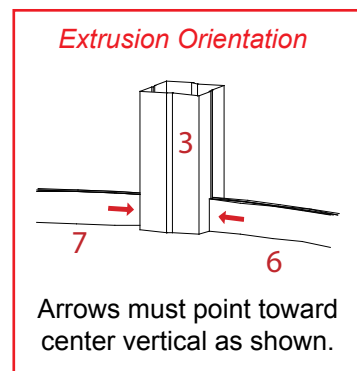
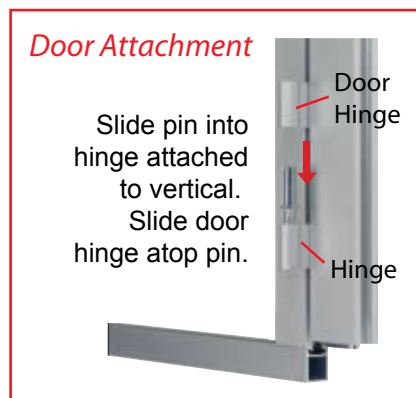
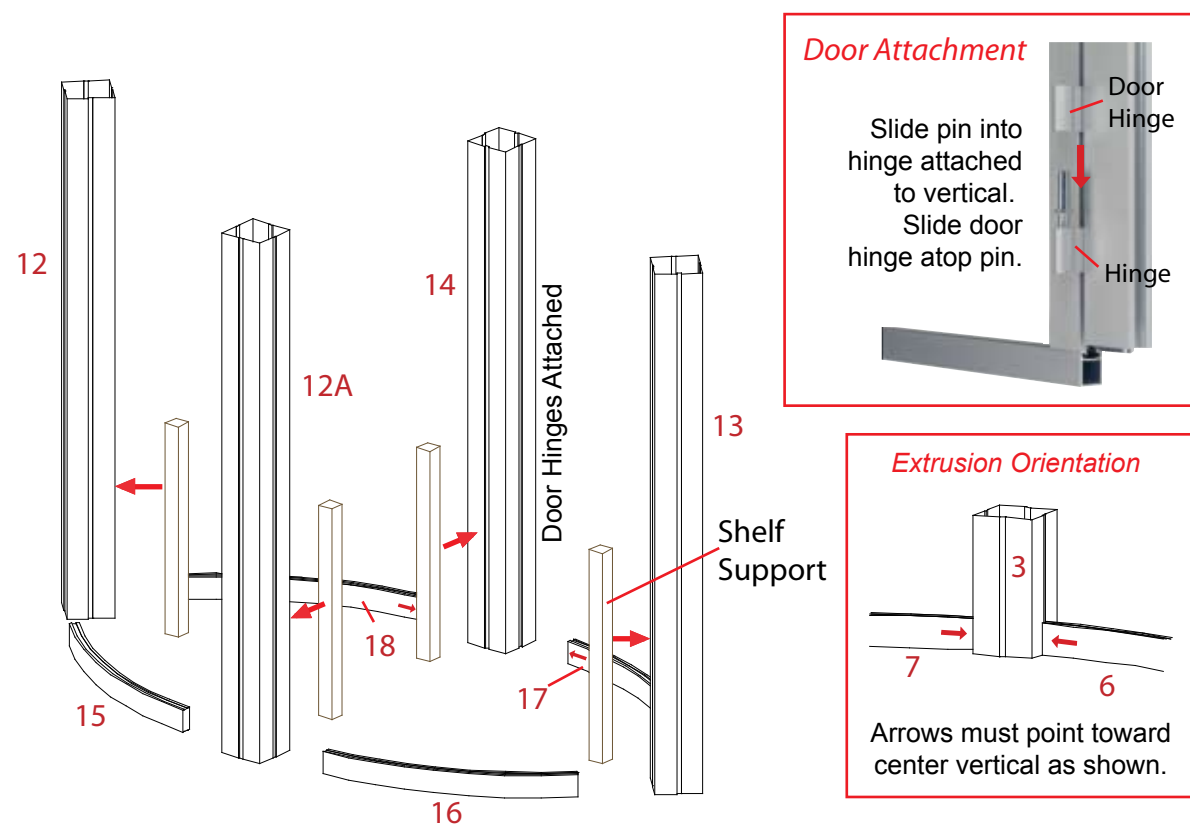

**WHEN DISASSEMBLING ALUMINUM EXTRUSION, TIGHTEN ALL SETSCREWS AND LOCKS TO PREVENT LOSS DURING SHIPPING**



**Using Your Setup Instructions**

The Aero Overhead Sign Setup Instructions are created specifically for your configuration. They include an exploded view of the frame which is sequentially numbered. We encourage you to study the instructions before attempting to assemble your exhibit.

Connections are kept very simple: no tools. Everything assembles with push-button connectors and pre-connected horizontal sections.

**Cleaning and Packing Your Display**

- 1) Use care when cleaning aluminum extrusion or acrylic inserts. Use only non-abrasive cleaners.
- 2) Retain all packing material. It will make re-packing much easier and will reduce the likelihood of shipping damage.

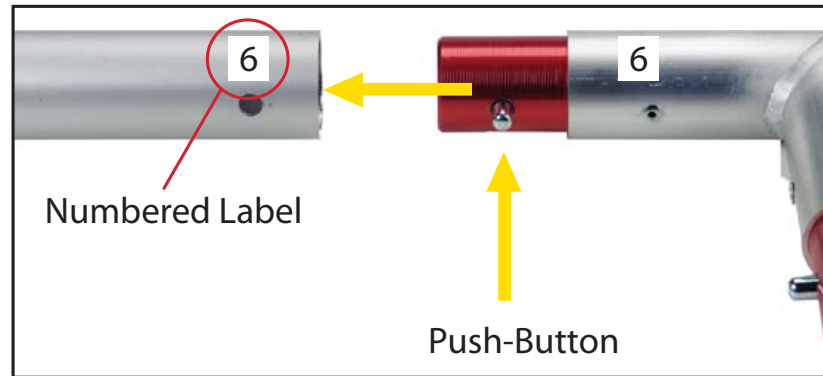
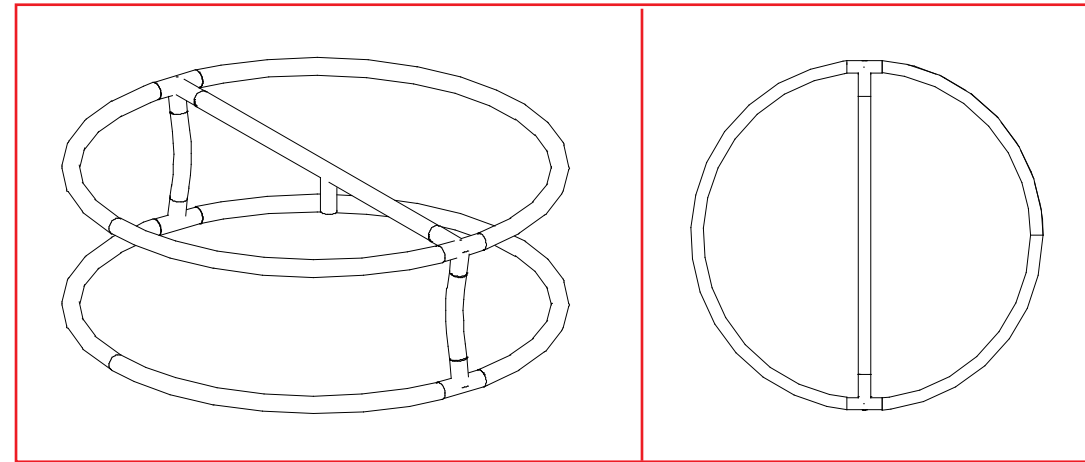

Connections are made by holding the button down and sliding the red tube into opposing tube until the connection is made. To disassemble push button and pull or twist extrusions apart.

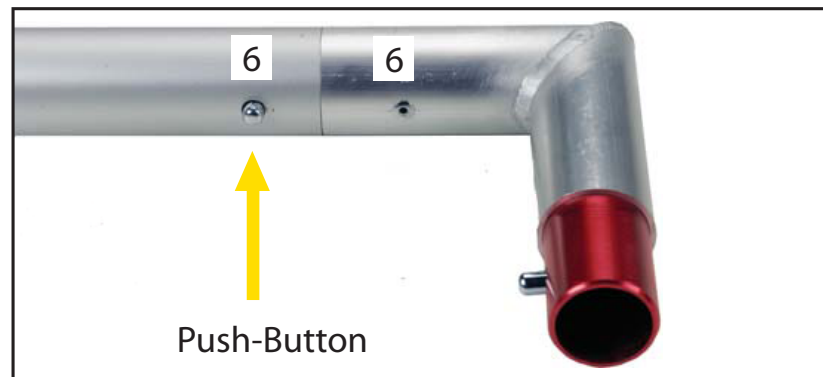

**Steps:**

- 1) Connect all pieces together in numerical order.
- 2) Drop assembled header to top of vertical extrusion as shown.

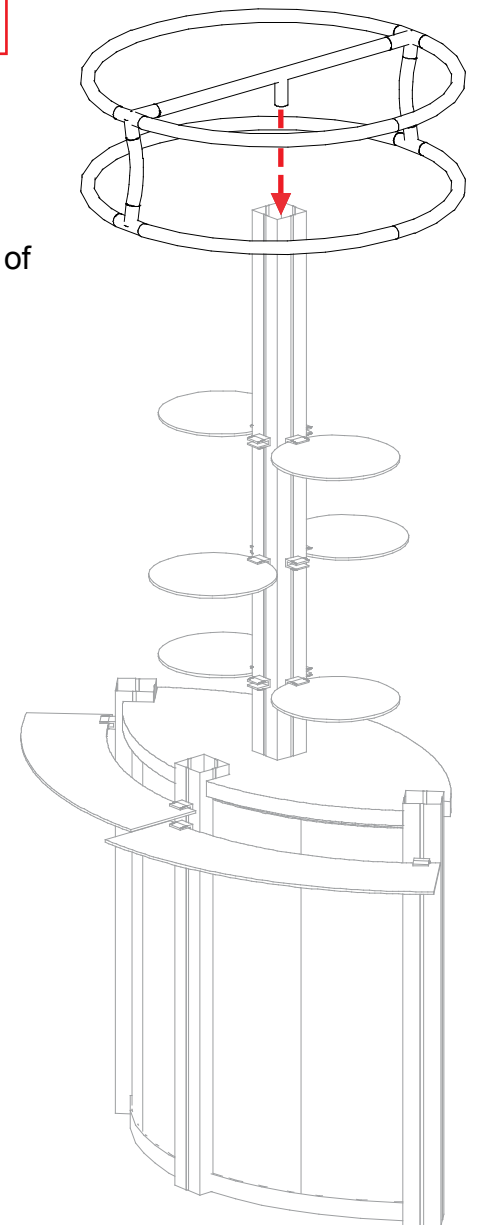
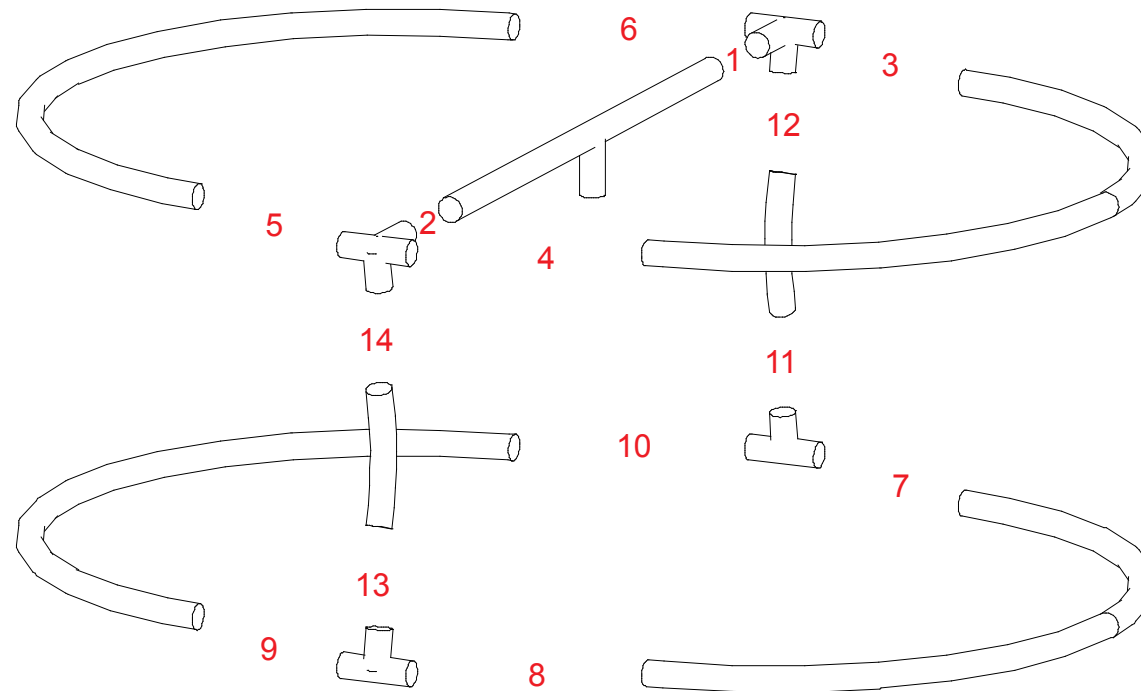

**WHEN DISASSEMBLING ALUMINUM EXTRUSION, TIGHTEN ALL SETSCREWS AND LOCKS TO PREVENT LOSS DURING SHIPPING**

# visionary™ IDESIGNS

## Using Your Setup Instructions

The Visionary Designs Setup Instructions are created specifically for your configuration. They are laid out sequentially, including an exploded view of the entire display, and then a logical series of detailed steps to assemble the main structure and components. We encourage you to study the instructions **before** attempting to assemble your exhibit.

Each page reminds you to tighten the setscrews after disassembling your exhibit to prevent loss of the locks and setscrews (see below in RED). This is VERY IMPORTANT.

## Cleaning and Packing Your Display

- 1) Use care when cleaning aluminum extrusion or acrylic inserts. Use only non-abrasive cleaners.
- 2) When cleaning laminate inserts or countertops, use mild cleansers and a soft material such as cotton.
- 3) Keep all display components away from extreme heat and long exposure to sunlight to avoid warping and fading.
- 4) Retain all packing material. It will make re-packing much easier and will reduce the likelihood of shipping damage.



The Tool

Most Visionary Designs exhibits can be assembled with the supplied Hex Key Tool. Occasionally, a flat head screwdriver may be required.



Typical Connection

Most horizontal extrusion connections have a patented expandable lock. This lock inserts into the groove of an opposing extrusion. Tightening the lock with the Hex Key Tool expands the lock and creates a strong positive connection.



Typical Connection (cont'd)

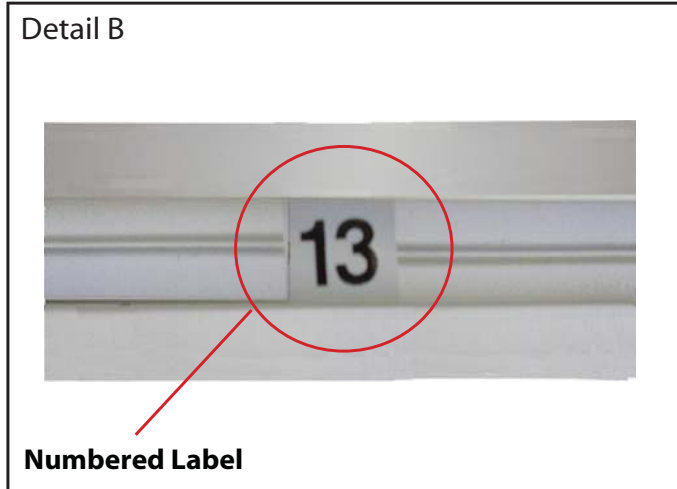

Detail B

Numbered Label

Each extrusion contains a numbered label which corresponds with setup instructions. The label is located within a groove of the extrusion (when possible). With Visionary Designs the labels contain Black numbers unless otherwise specified.



Detail C

Horizontal Inline Connection (remove only one setscrew)

Remove only (1) setscrew when disassembling. Replace setscrew in extrusion after assembling it. Before packing, replace setscrew in extrusion to avoid losing it.

**NOTE :**

PDF copies of your Setup Instructions are available @ [www.classicexhibits.com](http://www.classicexhibits.com)  
 Use the Search Tool located on the lower left-hand corner of the Classic Home  
 Enter your 5-7 digit Order #.

Search for Setup Instructions

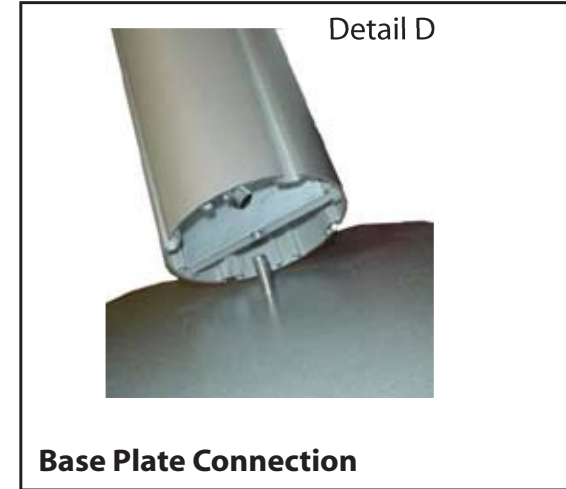

Detail D

Base Plate Connection

Attach base plate to round or square vertical extrusion using the bolt provided. Be careful not to strip the threads.

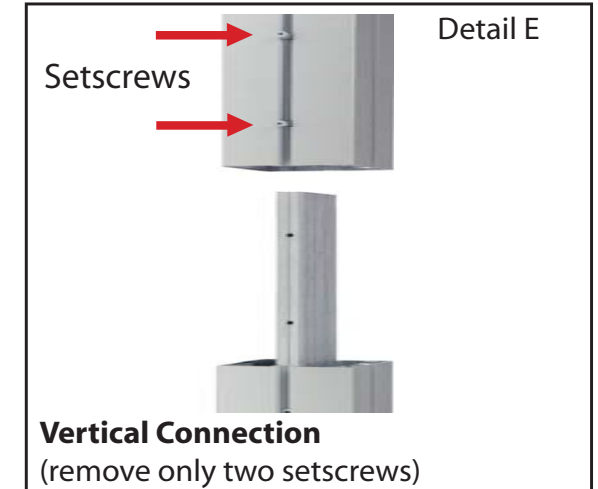

Detail E

Vertical Connection (remove only two setscrews)

When vertical extrusions are packed in portable cases rather than crates or tubs, they must be broken down into smaller sections which then require assembly.

Remove only (2) setscrews when disassembling. Replace setscrews in extrusion after assembling it. Before packing, replace setscrews in extrusion to avoid losing them.

**WHEN DISASSEMBLING ALUMINUM EXTRUSION, TIGHTEN ALL SETSCREWS AND LOCKS TO PREVENT LOSS DURING SHIPPING**

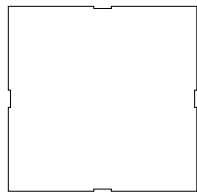

42" Square Extrusion  
Qty. : 3

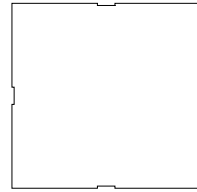

26.875" Square Extrusion  
Qty. : 2

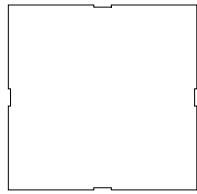

40.5" Square Extrusion  
Qty. : 1

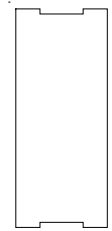

20.09" w Curved Horizontal Extrusion  
Qty. : 8

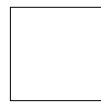

Internal Shelf Support  
Qty. : 4

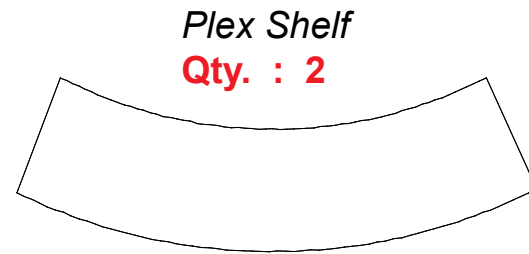

Plex Shelf  
Qty. : 2

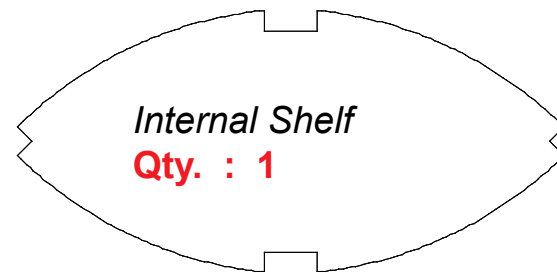

Internal Shelf  
Qty. : 1

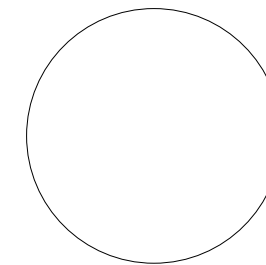

Round Shelf  
Qty. : 6

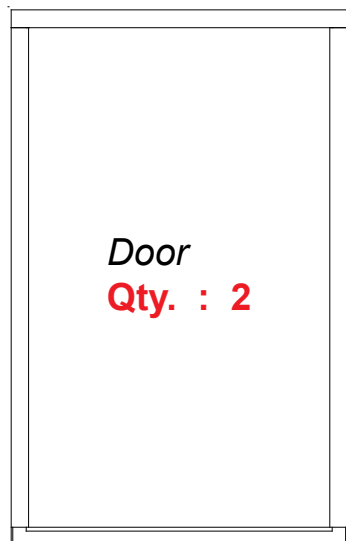

Door  
Qty. : 2

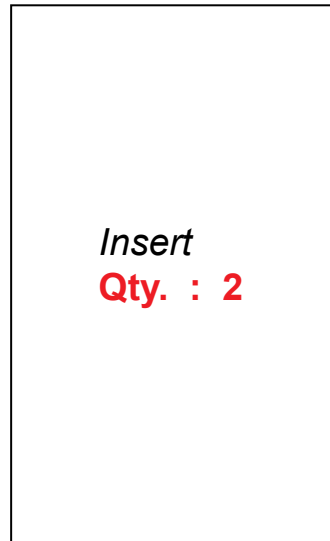

Insert  
Qty. : 2

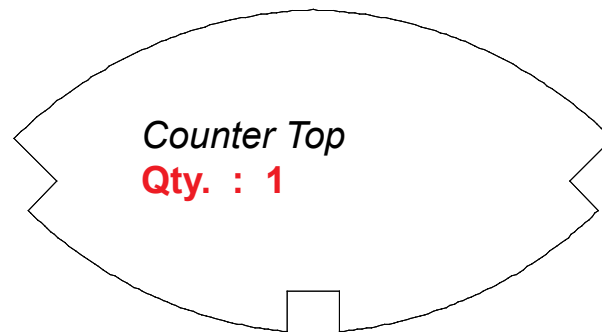

Counter Top  
Qty. : 1

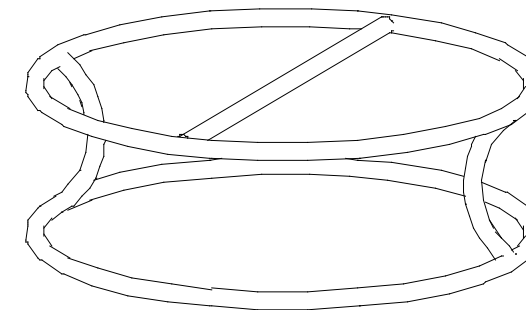

Header Frame  
Qty. : 1

Additional Accessories:

Setup Hardware

(10) A10 Clamps

Graphic

WHEN DISASSEMBLING ALUMINUM EXTRUSION, TIGHTEN ALL SETSCREWS AND LOCKS TO PREVENT LOSS DURING SHIPPING



Part Number	Qty for Step	Description
12/12A	1/1	42" h Vertical Extrusion
13	1	42" h Vertical Extrusion w/ Door Stop
14	1	40.5" h Vertical Extrusion w/ Door Hinges
15	1	20.09" w Curved Horizontal Extrusion
16	1	20.09" w Curved Horizontal Extrusion
17	1	20.09" w Curved Horizontal Extrusion
18	1	20.09" w Curved Horizontal Extrusion
19	1	20.09" w Curved Horizontal Extrusion
20	1	20.09" w Curved Horizontal Extrusion
21	1	20.09" w Curved Horizontal Extrusion
22	1	20.09" w Curved Horizontal Extrusion
23	1	26.875" h Square Vertical Extrusion
24	1	26.875" h Square Vertical Extrusion

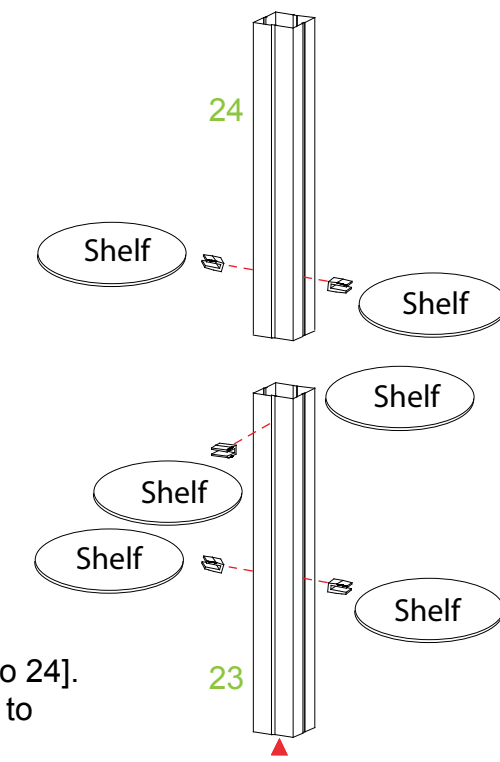
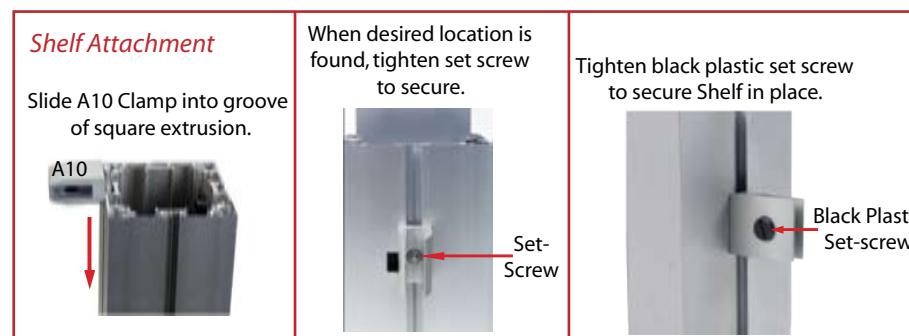

**Steps:**

- 1) Connect horizontal extrusions [15, 16, 17 and 18] between vertical extrusions [12, 12A, 13 and 14] where indicated.
- 2) Place inserts and attach door where indicated.
- 3) Connect upper horizontal extrusions [19, 20, 21 and 22] between vertical extrusions [12, 12A, 13 and 14].
- 4) Velcro internal shelf supports to inside of assembled base.
- 5) Set internal shelf and counter top as shown.
- 6) Attach Plex shelves to pedestal using A10 clamps, see Shelf Attachment details.

**Steps:**

- 7) Connect square extrusions [23 to 24].
- 8) Attach vertical assembly [23/24] to counter top using provided bolt.

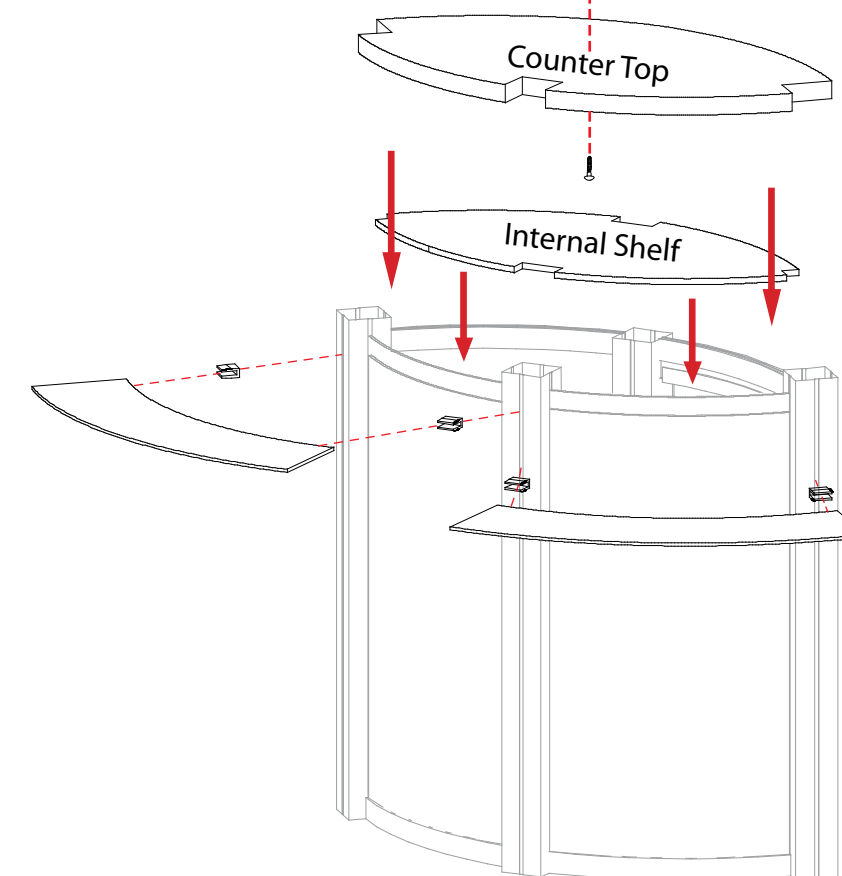
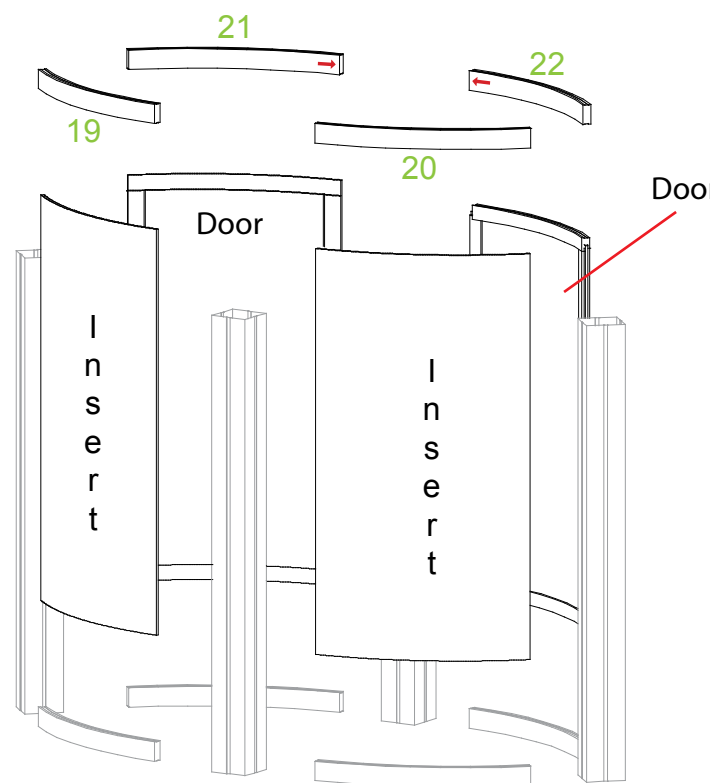
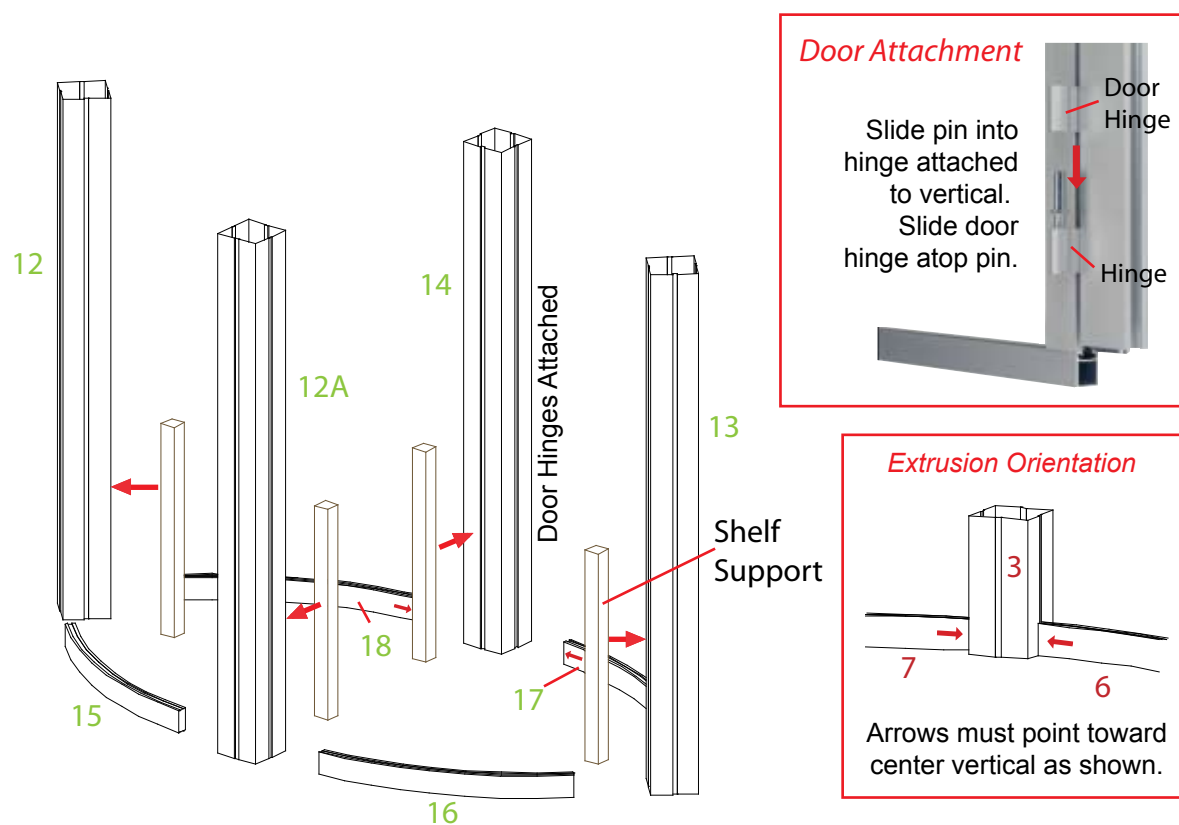

**WHEN DISASSEMBLING ALUMINUM EXTRUSION, TIGHTEN ALL SETSCREWS AND LOCKS TO PREVENT LOSS DURING SHIPPING**



**Using Your Setup Instructions**

The Aero Overhead Sign Setup Instructions are created specifically for your configuration. They include an exploded view of the frame which is sequentially numbered. We encourage you to study the instructions before attempting to assemble your exhibit.

Connections are kept very simple: no tools. Everything assembles with push-button connectors and pre-connected horizontal sections.

**Cleaning and Packing Your Display**

- 1) Use care when cleaning aluminum extrusion or acrylic inserts. Use only non-abrasive cleaners.
- 2) Retain all packing material. It will make re-packing much easier and will reduce the likelihood of shipping damage.

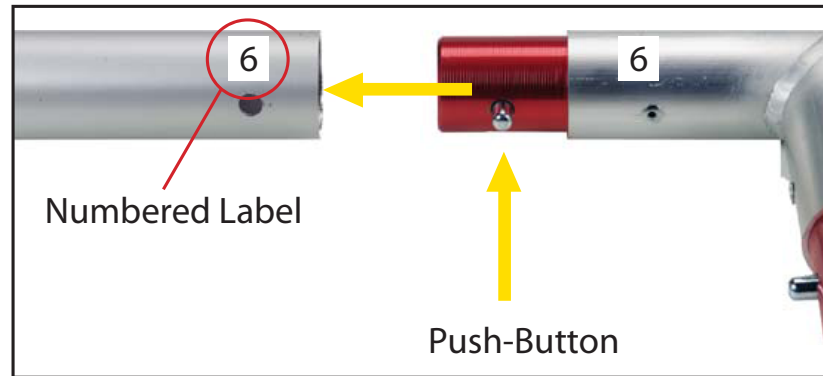
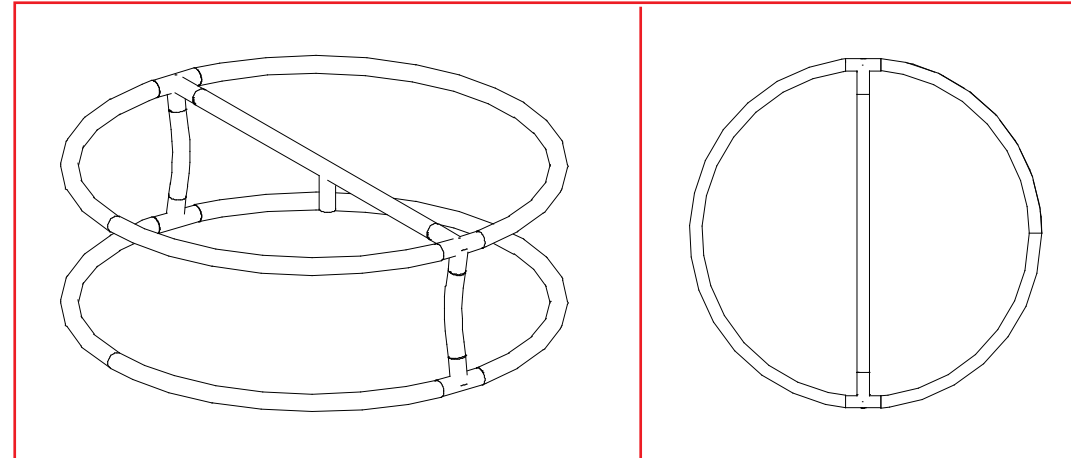

Connections are made by holding the button down and sliding the red tube into opposing tube until the connection is made. To disassemble push button and pull or twist extrusions apart.

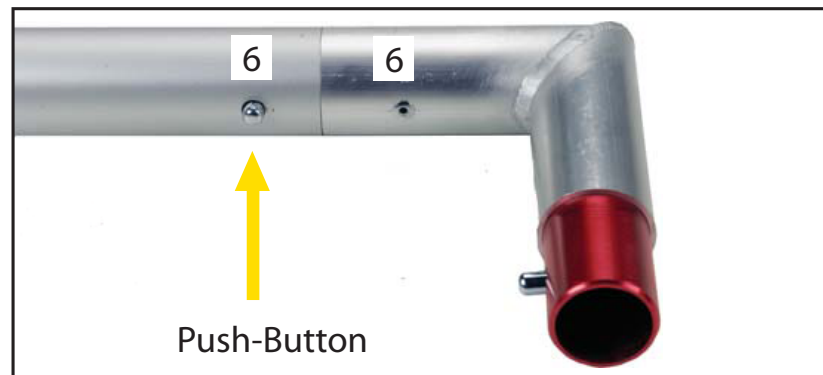

**Steps:**

- 1) Connect all pieces together in numerical order.
- 2) Drop assembled header to top of vertical extrusion as shown.

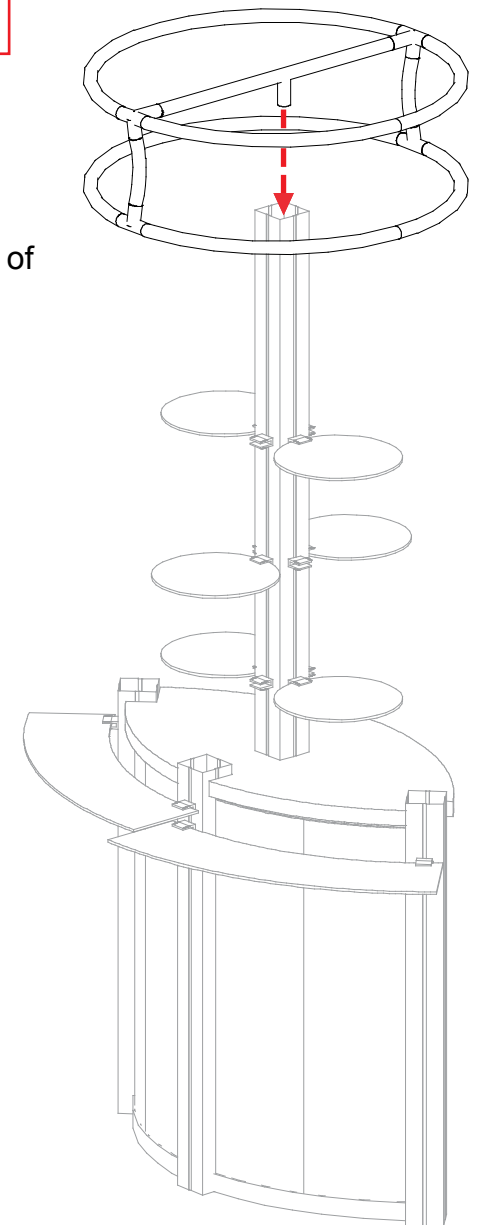
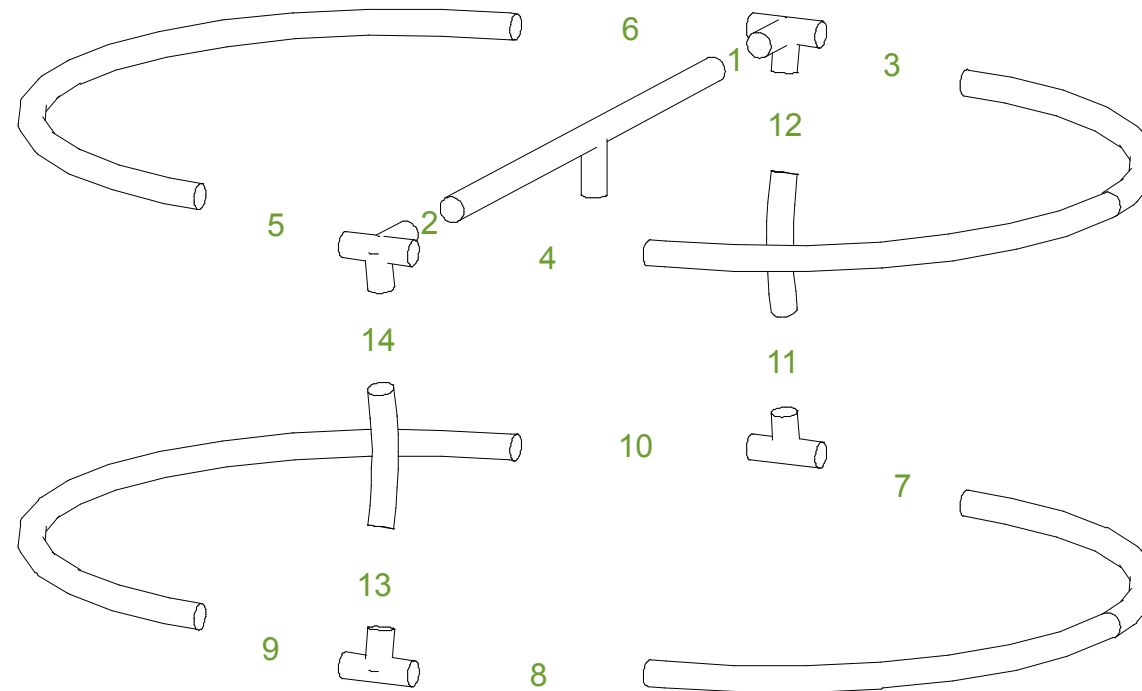

**WHEN DISASSEMBLING ALUMINUM EXTRUSION, TIGHTEN ALL SETSCREWS AND LOCKS TO PREVENT LOSS DURING SHIPPING**

# visionary™ IDESIGNS

## Using Your Setup Instructions

The Visionary Designs Setup Instructions are created specifically for your configuration. They are laid out sequentially, including an exploded view of the entire display, and then a logical series of detailed steps to assemble the main structure and components. We encourage you to study the instructions **before** attempting to assemble your exhibit.

Each page reminds you to tighten the setscrews after disassembling your exhibit to prevent loss of the locks and setscrews (see below in RED). This is **VERY IMPORTANT**.

## Cleaning and Packing Your Display

- 1) Use care when cleaning aluminum extrusion or acrylic inserts. Use only non-abrasive cleaners.
- 2) When cleaning laminate inserts or countertops, use mild cleansers and a soft material such as cotton.
- 3) Keep all display components away from extreme heat and long exposure to sunlight to avoid warping and fading.
- 4) Retain all packing material. It will make re-packing much easier and will reduce the likelihood of shipping damage.



The Tool

Most Visionary Designs exhibits can be assembled with the supplied Hex Key Tool. Occasionally, a flat head screwdriver may be required.



Detail A

Typical Connection



Typical Connection (cont'd)

Most horizontal extrusion connections have a patented expandable lock. This lock inserts into the groove of an opposing extrusion. Tightening the lock with the Hex Key Tool expands the lock and creates a strong positive connection.

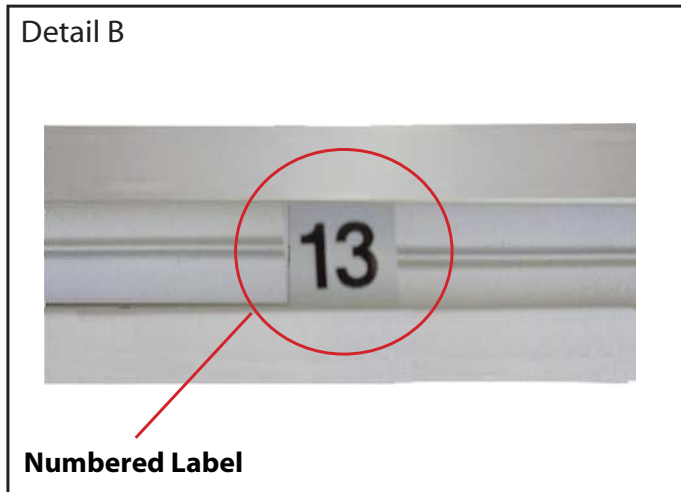

Detail B

Numbered Label

Each extrusion contains a numbered label which corresponds with setup instructions. The label is located within a groove of the extrusion (when possible). With Visionary Designs the labels contain Black numbers unless otherwise specified.



Detail C

Horizontal Inline Connection (remove only one setscrew)

Remove only (1) setscrew when disassembling. Replace setscrew in extrusion after assembling it. Before packing, replace setscrew in extrusion to avoid losing it.

**NOTE :**

PDF copies of your Setup Instructions are available @ [www.classicexhibits.com](http://www.classicexhibits.com)  
 Use the Search Tool located on the lower left-hand corner of the Classic Home  
 Enter your 5-7 digit Order #.

Search for Setup Instructions

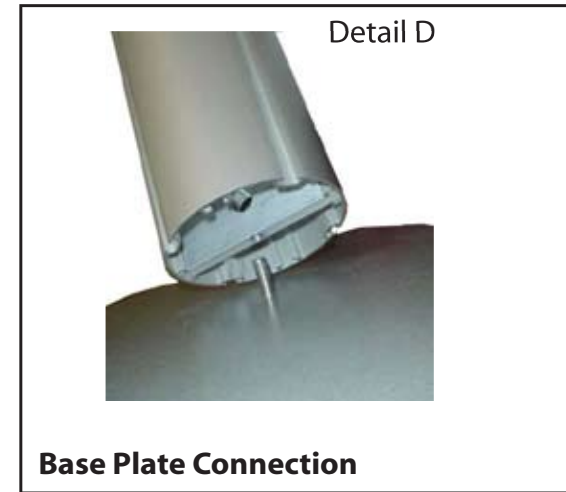

Detail D

Base Plate Connection

Attach base plate to round or square vertical extrusion using the bolt provided. Be careful not to strip the threads.

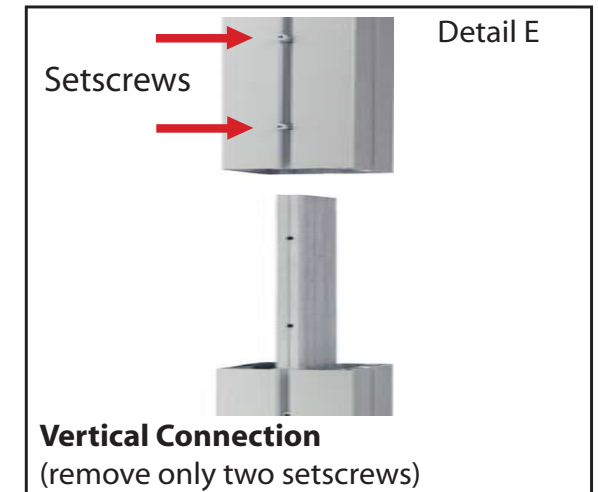

Detail E

Vertical Connection (remove only two setscrews)

When vertical extrusions are packed in portable cases rather than crates or tubs, they must be broken down into smaller sections which then require assembly.

Remove only (2) setscrews when disassembling. Replace setscrews in extrusion after assembling it. Before packing, replace setscrews in extrusion to avoid losing them.

**WHEN DISASSEMBLING ALUMINUM EXTRUSION, TIGHTEN ALL SETSCREWS AND LOCKS TO PREVENT LOSS DURING SHIPPING**

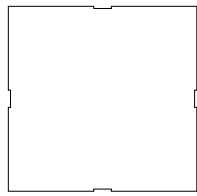

42" Square Extrusion  
Qty. : 3

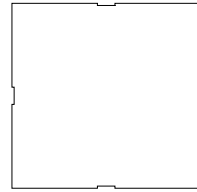

26.875" Square Extrusion  
Qty. : 2

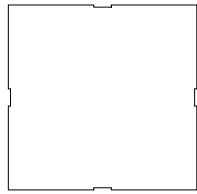

40.5" Square Extrusion  
Qty. : 1

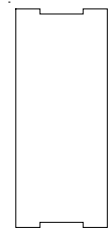

20.09" w Curved Horizontal Extrusion  
Qty. : 8

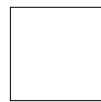

Internal Shelf Support  
Qty. : 4

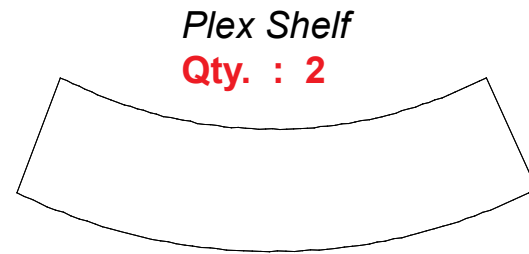

Plex Shelf  
Qty. : 2

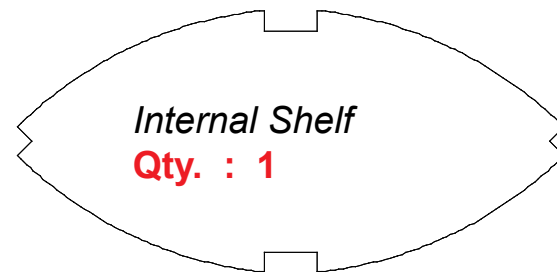

Internal Shelf  
Qty. : 1

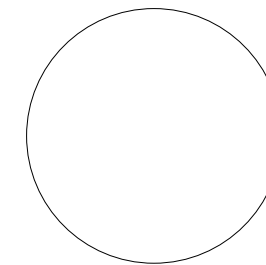

Round Shelf  
Qty. : 6

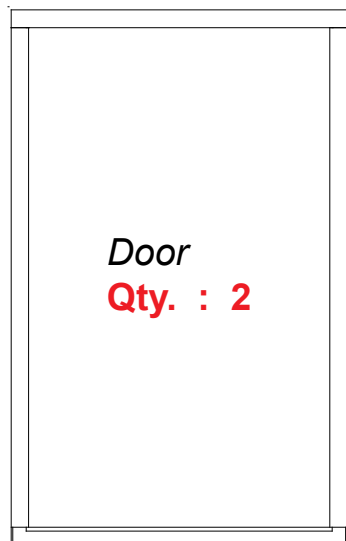

Door  
Qty. : 2

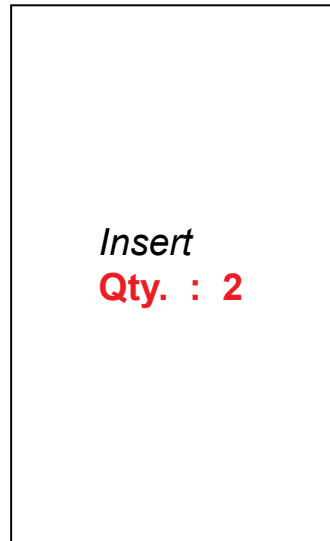

Insert  
Qty. : 2

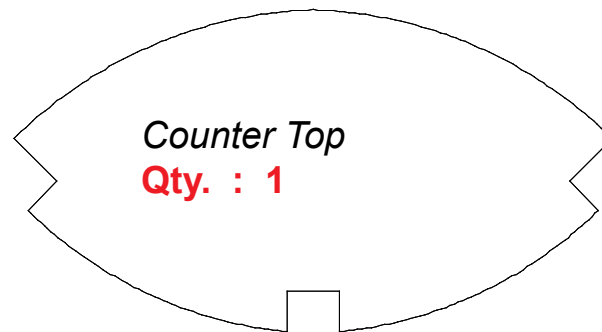

Counter Top  
Qty. : 1

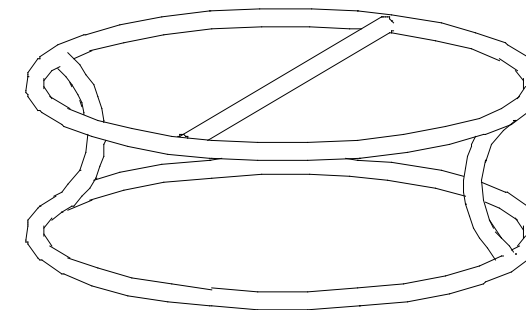

Header Frame  
Qty. : 1

Additional Accessories:

Setup Hardware

(10) A10 Clamps

Graphic

WHEN DISASSEMBLING ALUMINUM EXTRUSION, TIGHTEN ALL SETSCREWS AND LOCKS TO PREVENT LOSS DURING SHIPPING



Part Number	Qty for Step	Description
12/12A	1/1	42" h Vertical Extrusion
13	1	42" h Vertical Extrusion w/ Door Stop
14	1	40.5" h Vertical Extrusion w/ Door Hinges
15	1	20.09" w Curved Horizontal Extrusion
16	1	20.09" w Curved Horizontal Extrusion
17	1	20.09" w Curved Horizontal Extrusion
18	1	20.09" w Curved Horizontal Extrusion
19	1	20.09" w Curved Horizontal Extrusion
20	1	20.09" w Curved Horizontal Extrusion
21	1	20.09" w Curved Horizontal Extrusion
22	1	20.09" w Curved Horizontal Extrusion
23	1	26.875" h Square Vertical Extrusion
24	1	26.875" h Square Vertical Extrusion

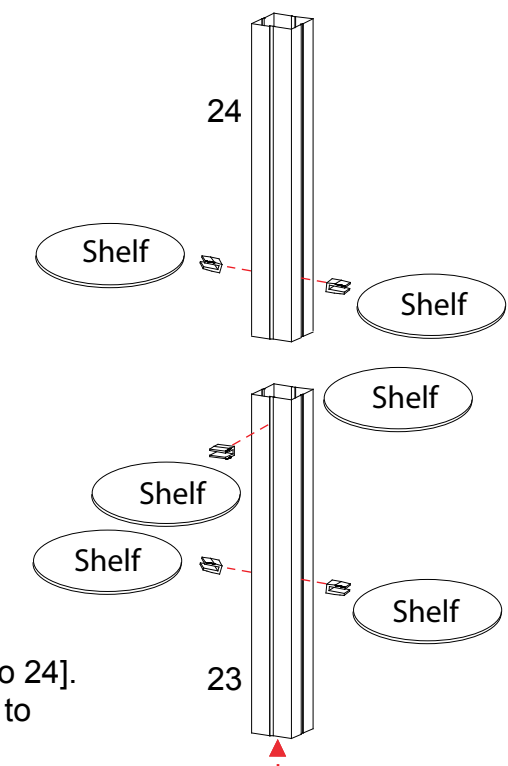
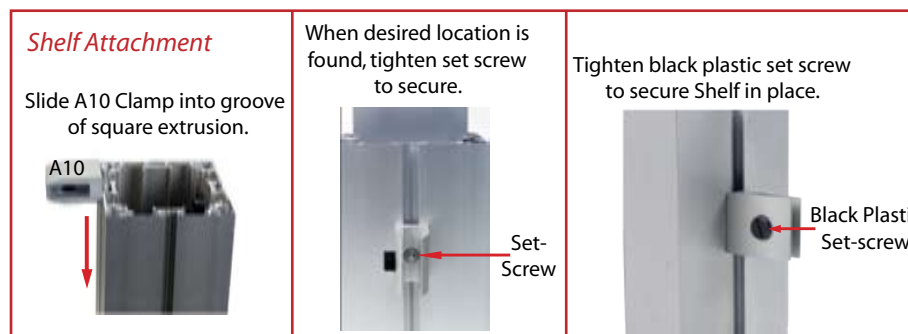

**Steps:**

- 1) Connect horizontal extrusions [15, 16, 17 and 18] between vertical extrusions [12, 12A, 13 and 14] where indicated.
- 2) Place inserts and attach door where indicated.
- 3) Connect upper horizontal extrusions [19, 20, 21 and 22] between vertical extrusions [12, 12A, 13 and 14].
- 4) Velcro internal shelf supports to inside of assembled base.
- 5) Set internal shelf and counter top as shown.
- 6) Attach Plex shelves to pedestal using A10 clamps, see Shelf Attachment details.

**Steps:**

- 7) Connect square extrusions [23 to 24].
- 8) Attach vertical assembly [23/24] to counter top using provided bolt.

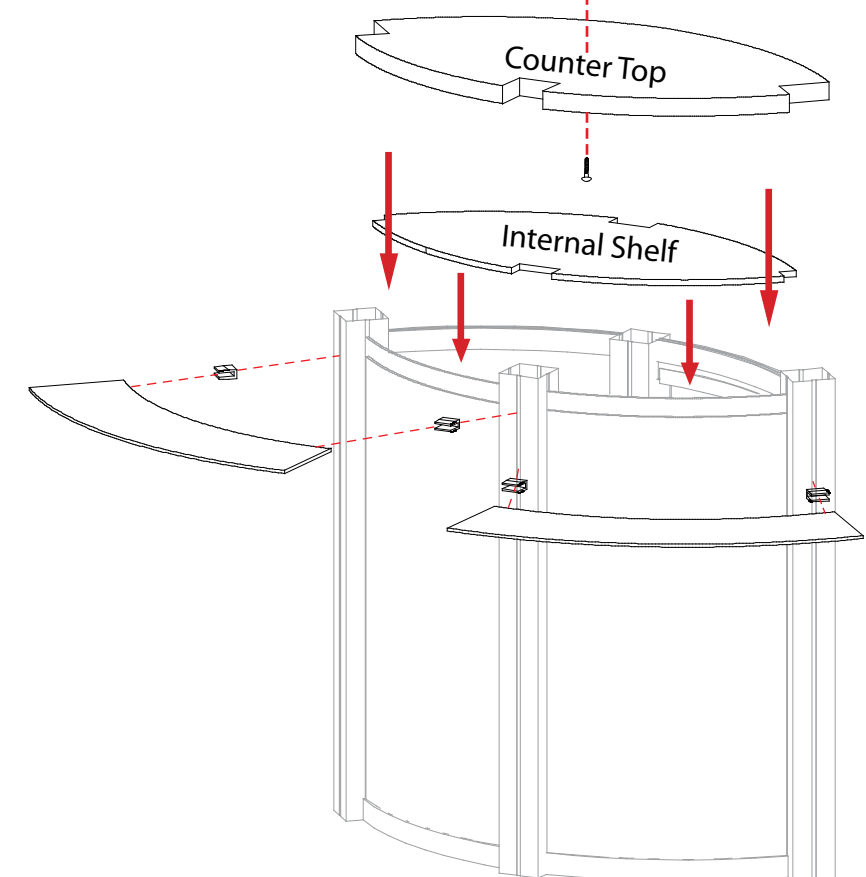
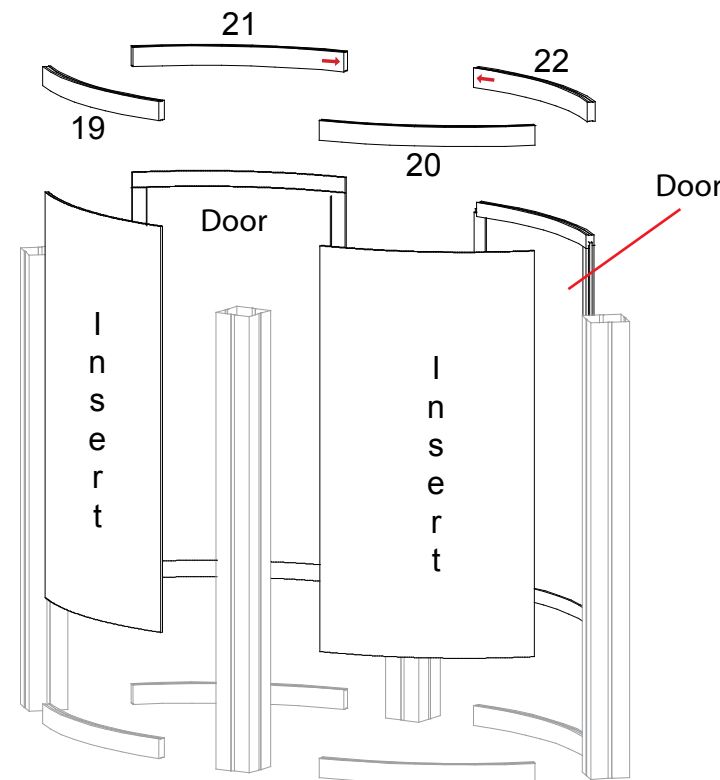
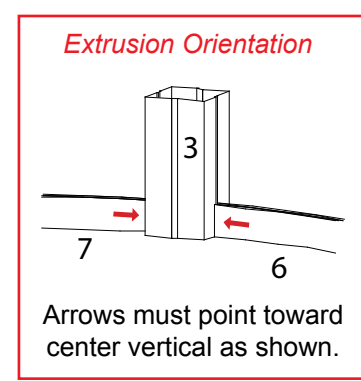
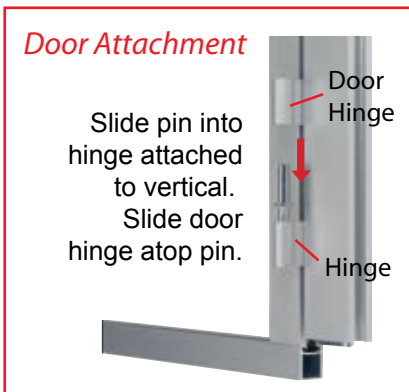
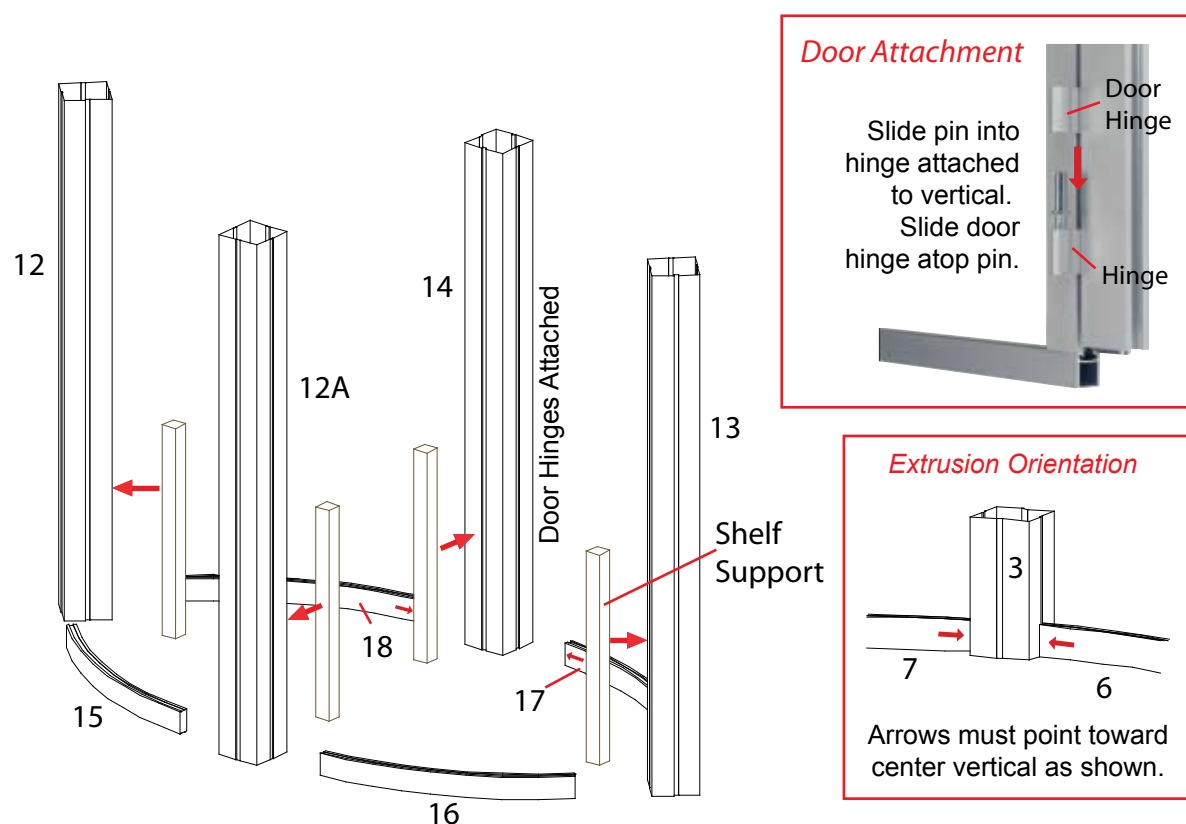

**WHEN DISASSEMBLING ALUMINUM EXTRUSION, TIGHTEN ALL SETSCREWS AND LOCKS TO PREVENT LOSS DURING SHIPPING**



866.652.2100

**Using Your Setup Instructions**

The Aero Overhead Sign Setup Instructions are created specifically for your configuration. They include an exploded view of the frame which is sequentially numbered. We encourage you to study the instructions before attempting to assemble your exhibit.

Connections are kept very simple: no tools. Everything assembles with push-button connectors and pre-connected horizontal sections.

**Cleaning and Packing Your Display**

- 1) Use care when cleaning aluminum extrusion or acrylic inserts. Use only non-abrasive cleaners.
- 2) Retain all packing material. It will make re-packing much easier and will reduce the likelihood of shipping damage.

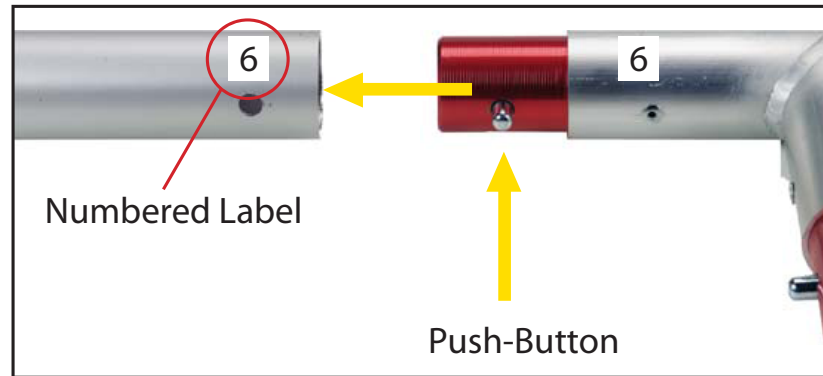
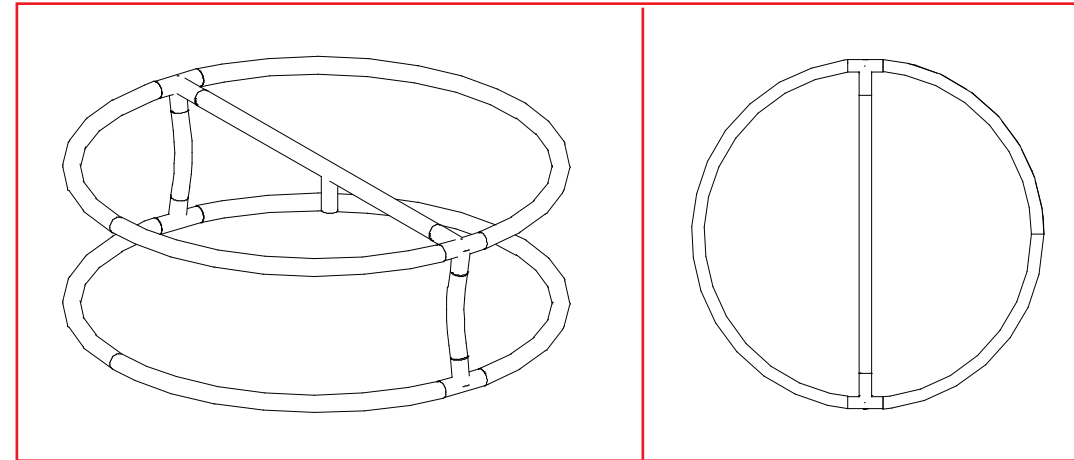

Connections are made by holding the button down and sliding the red tube into opposing tube until the connection is made. To disassemble push button and pull or twist extrusions apart.

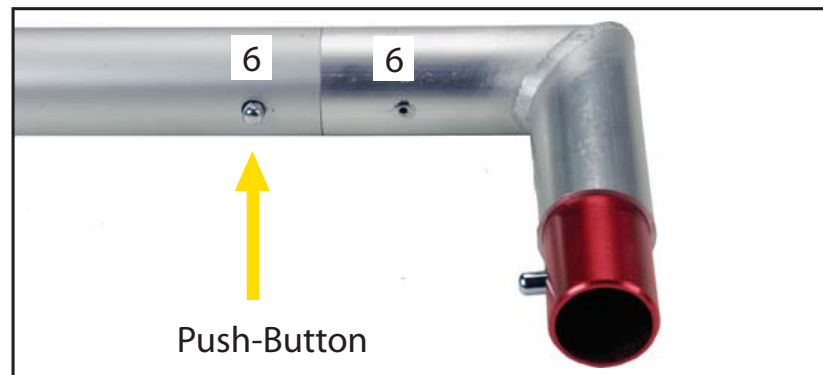

**Steps:**

- 1) Connect all pieces together in numerical order.
- 2) Drop assembled header to top of vertical extrusion as shown.

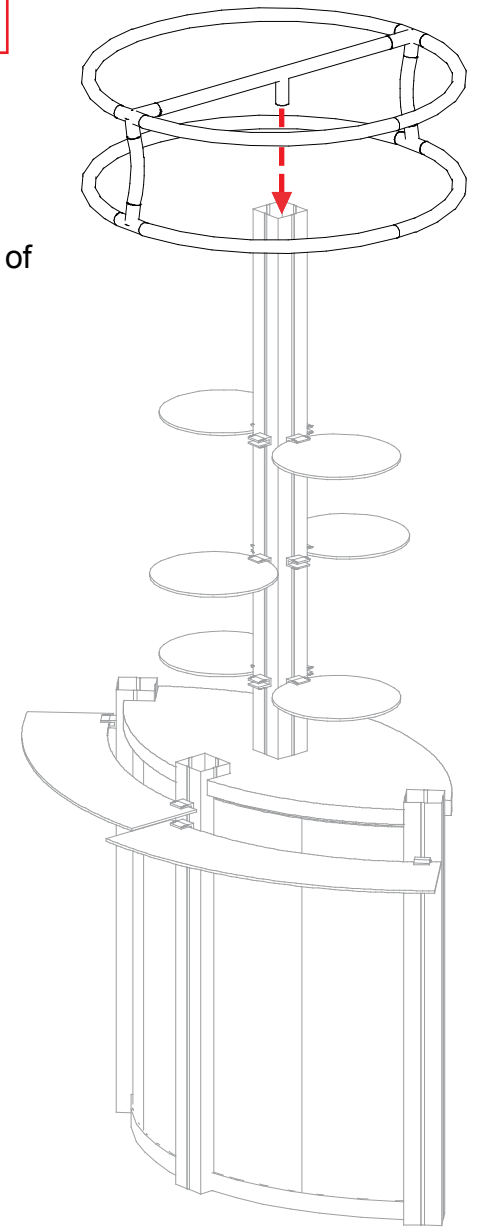
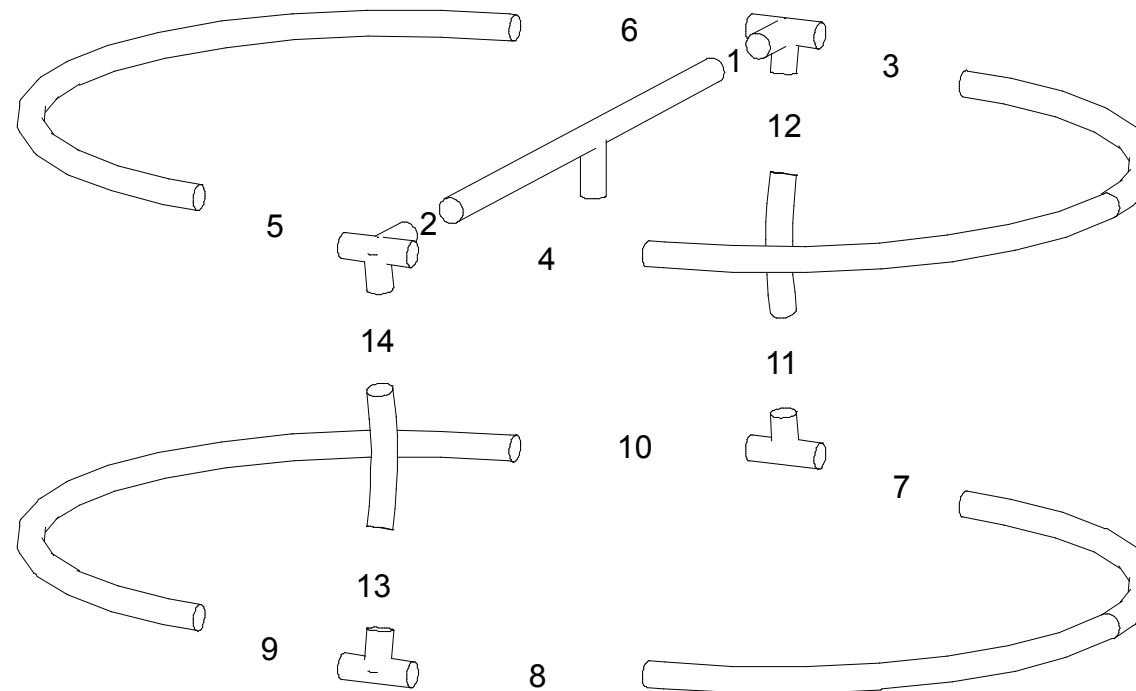

**WHEN DISASSEMBLING ALUMINUM EXTRUSION, TIGHTEN ALL SETSCREWS AND LOCKS TO PREVENT LOSS DURING SHIPPING**

# visionary™ IDESIGNS

## Using Your Setup Instructions

The Visionary Designs Setup Instructions are created specifically for your configuration. They are laid out sequentially, including an exploded view of the entire display, and then a logical series of detailed steps to assemble the main structure and components. We encourage you to study the instructions **before** attempting to assemble your exhibit.

Each page reminds you to tighten the setscrews after disassembling your exhibit to prevent loss of the locks and setscrews (see below in RED). This is VERY IMPORTANT.

## Cleaning and Packing Your Display

- 1) Use care when cleaning aluminum extrusion or acrylic inserts. Use only non-abrasive cleaners.
- 2) When cleaning laminate inserts or countertops, use mild cleansers and a soft material such as cotton.
- 3) Keep all display components away from extreme heat and long exposure to sunlight to avoid warping and fading.
- 4) Retain all packing material. It will make re-packing much easier and will reduce the likelihood of shipping damage.



The Tool

Most Visionary Designs exhibits can be assembled with the supplied Hex Key Tool. Occasionally, a flat head screwdriver may be required.



Typical Connection

Most horizontal extrusion connections have a patented expandable lock. This lock inserts into the groove of an opposing extrusion. Tightening the lock with the Hex Key Tool expands the lock and creates a strong positive connection.



Typical Connection (cont'd)

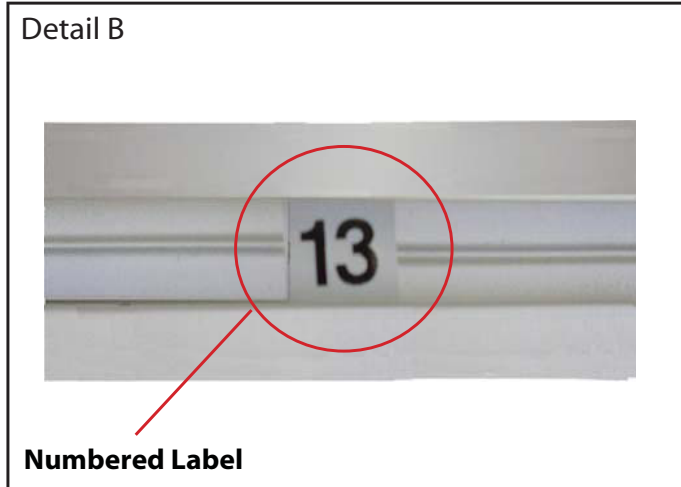

Detail B

Numbered Label

Each extrusion contains a numbered label which corresponds with setup instructions. The label is located within a groove of the extrusion (when possible). With Visionary Designs the labels contain Black numbers unless otherwise specified.



Detail C

Horizontal Inline Connection (remove only one setscrew)

Remove only (1) setscrew when disassembling. Replace setscrew in extrusion after assembling it. Before packing, replace setscrew in extrusion to avoid losing it.

**NOTE :**

PDF copies of your Setup Instructions are available @ [www.classicexhibits.com](http://www.classicexhibits.com)  
 Use the Search Tool located on the lower left-hand corner of the Classic Home  
 Enter your 5-7 digit Order #.

Search for Setup Instructions

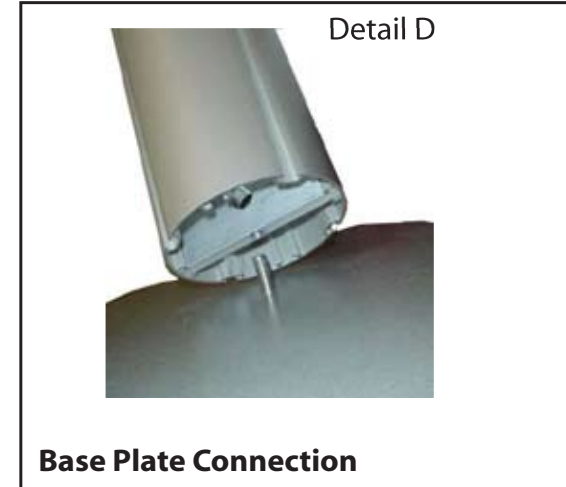

Detail D

Base Plate Connection

Attach base plate to round or square vertical extrusion using the bolt provided. Be careful not to strip the threads.

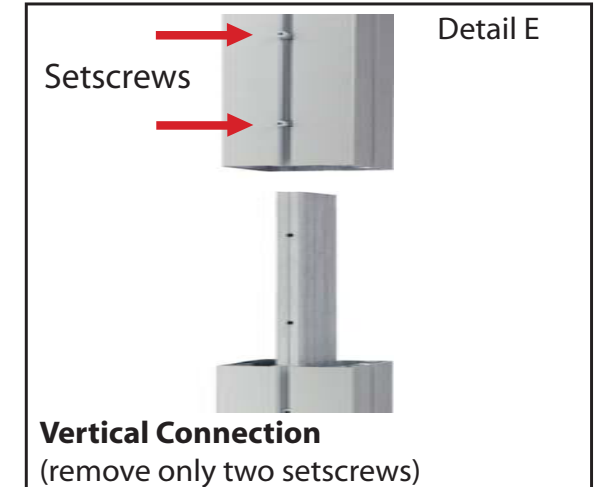

Detail E

Vertical Connection (remove only two setscrews)

When vertical extrusions are packed in portable cases rather than crates or tubs, they must be broken down into smaller sections which then require assembly.

Remove only (2) setscrews when disassembling. Replace setscrews in extrusion after assembling it. Before packing, replace setscrews in extrusion to avoid losing them.

**WHEN DISASSEMBLING ALUMINUM EXTRUSION, TIGHTEN ALL SETSCREWS AND LOCKS TO PREVENT LOSS DURING SHIPPING**

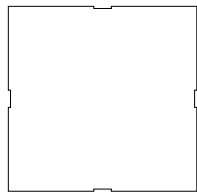

42" Square Extrusion  
Qty. : 3

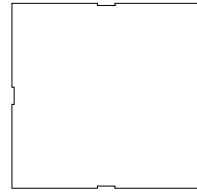

26.875" Square Extrusion  
Qty. : 2

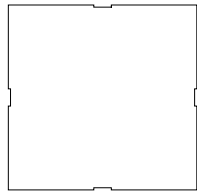

40.5" Square Extrusion  
Qty. : 1

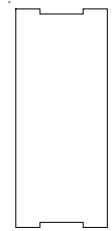

20.09" w Curved Horizontal Extrusion  
Qty. : 8

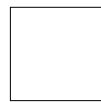

Internal Shelf Support  
Qty. : 4

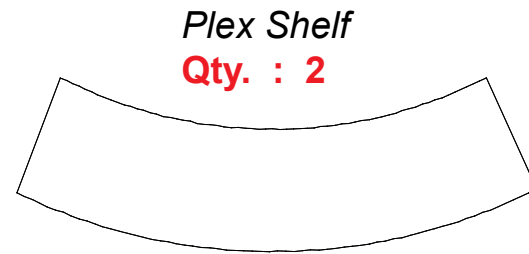

Plex Shelf  
Qty. : 2

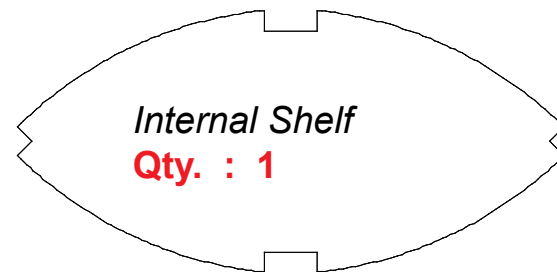

Internal Shelf  
Qty. : 1

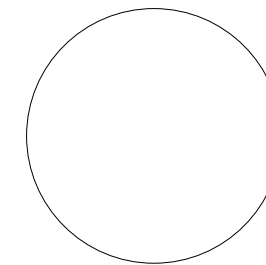

Round Shelf  
Qty. : 6

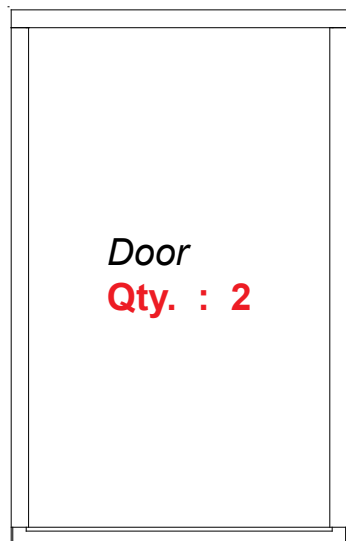

Door  
Qty. : 2

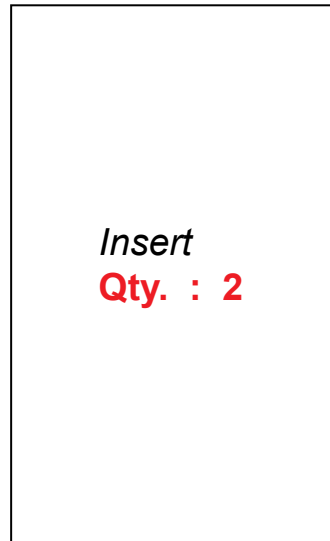

Insert  
Qty. : 2

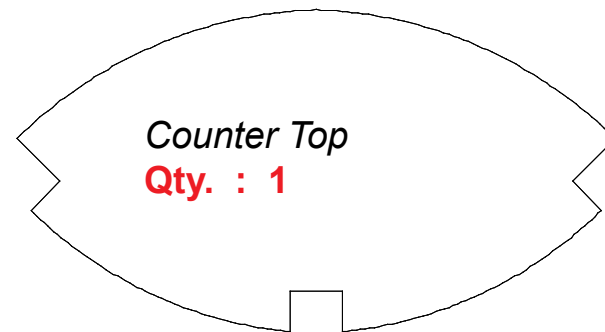

Counter Top  
Qty. : 1

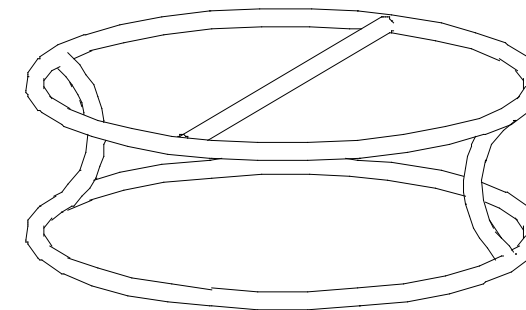

Header Frame  
Qty. : 1

Additional Accessories:

Setup Hardware

(10) A10 Clamps

Graphic

WHEN DISASSEMBLING ALUMINUM EXTRUSION, TIGHTEN ALL SETSCREWS AND LOCKS TO PREVENT LOSS DURING SHIPPING