

Perfect 10

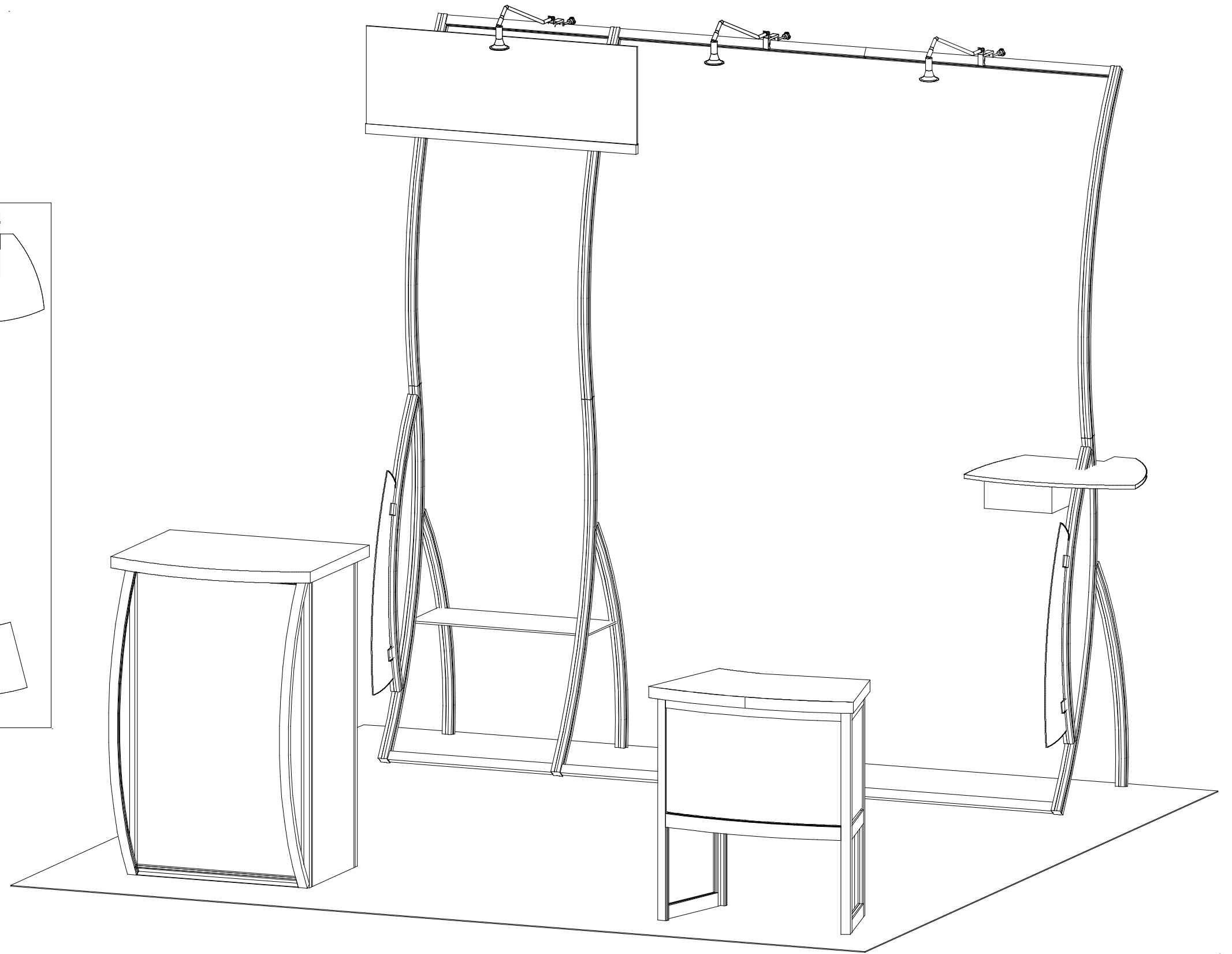
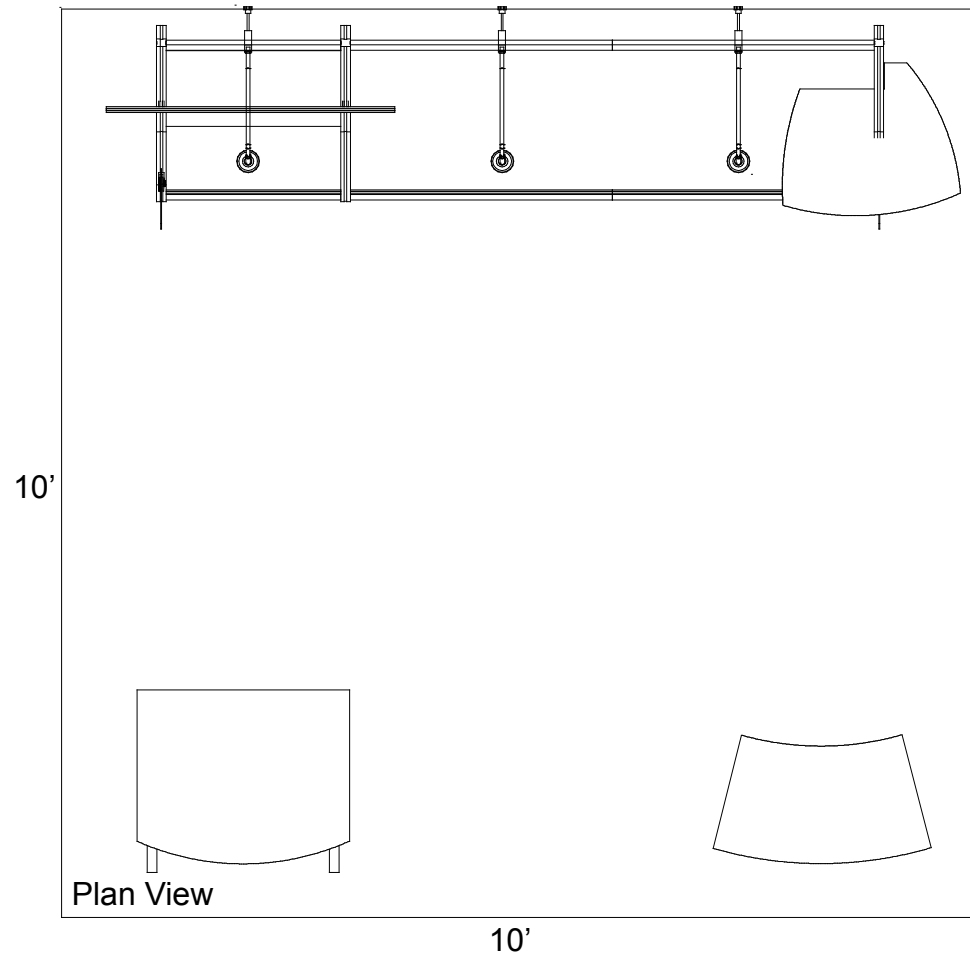

WHEN DISASSEMBLING TIGHTEN ALL BLACK KNOBS TO PREVENT LOSS DURING SHIPPING

866.652.2100

| Part Number | Description |
|-------------|--|
| 1 | Left Leg Assembly w/ A10 Clamps Attached |
| 2 | Middle Leg Assembly |
| 3A | Upper Curved Vertical w/ A10 Clamps Attached |
| 3 | Upper Curved Vertical |
| 4 | 23" w Horizontal |



Step 1:

NOTE: Can be assembled either face down on floor then lifted upright or upright as shown in drawings.

- A) Connect vertical leg assemblies [1 and 2] together by connecting horizontal extrusions [4] between assemblies tightening BLACK knobs on backside of extrusion making sure Velcro faces toward BACK and placing it about one inch up from bottom and tightening.
- B) Connect vertical extrusions [3 and 3A] to leg assemblies [1 and 2] using vertical connection bar as shown.
- C) Connect upper horizontal extrusion [4] between verticals [3 and 3A] placing it about one inch down from top.

NOTE: Make sure the lock is flush with extrusion before tightening. If lock will not fully engage, gently rock lock and extrusion while turning knob until lock fully opens.

Rear View of Display

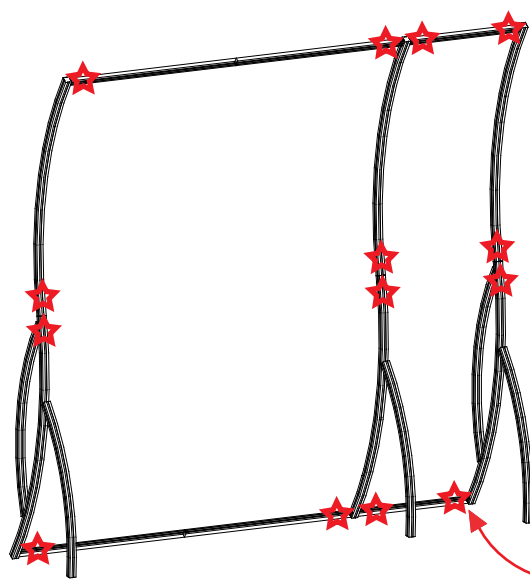

STAR indicates location of knobs on BACKSIDE of unit.

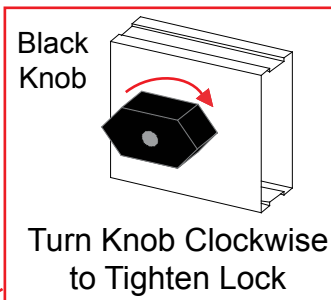

Step 1

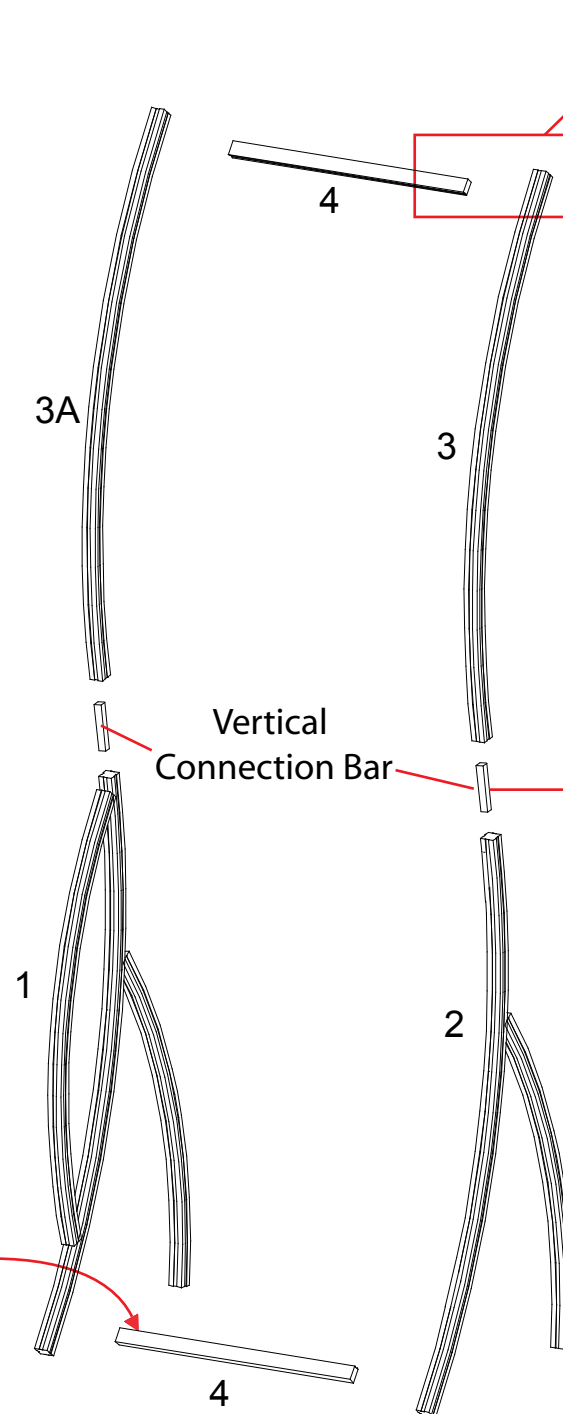

NOTE: When assembling horizontals they should be placed approximately one inch from TOP and BOTTOM.



Slide Connection Bar into lower leg assembly. Slide upper vertical over bar and secure both.

Step stool may be required for assembly.



WHEN DISASSEMBLING TIGHTEN ALL BLACK KNOBS TO PREVENT LOSS DURING SHIPPING

866.652.2100

| Part Number | Description |
|-------------|---------------------------------------|
| 5 | Right Leg Assembly |
| 6 | Upper Curved Vertical |
| 7 | 69" w Horizontal w/ Hinge Facing UP |
| 8 | 69" w Horizontal w/ Hinge Facing DOWN |

Step 2

Step 2:

NOTE: Can be assembled either face down on floor then lifted upright or upright as shown in drawings.

- A) Connect vertical extrusion [6] to leg assembly [5] using vertical connection bar as shown.
- B) Connect horizontal extrusions [7 and 8] between vertical assemblies by tightening BLACK knobs on backside of extrusion making sure Velcro faces toward BACK.

NOTE: Make sure the lock is flush with extrusion before tightening. If lock will not fully engage, gently rock lock and extrusion while turning knob until lock fully opens.



NOTE: When assembling horizontals they should be placed approximately one inch from TOP and BOTTOM.

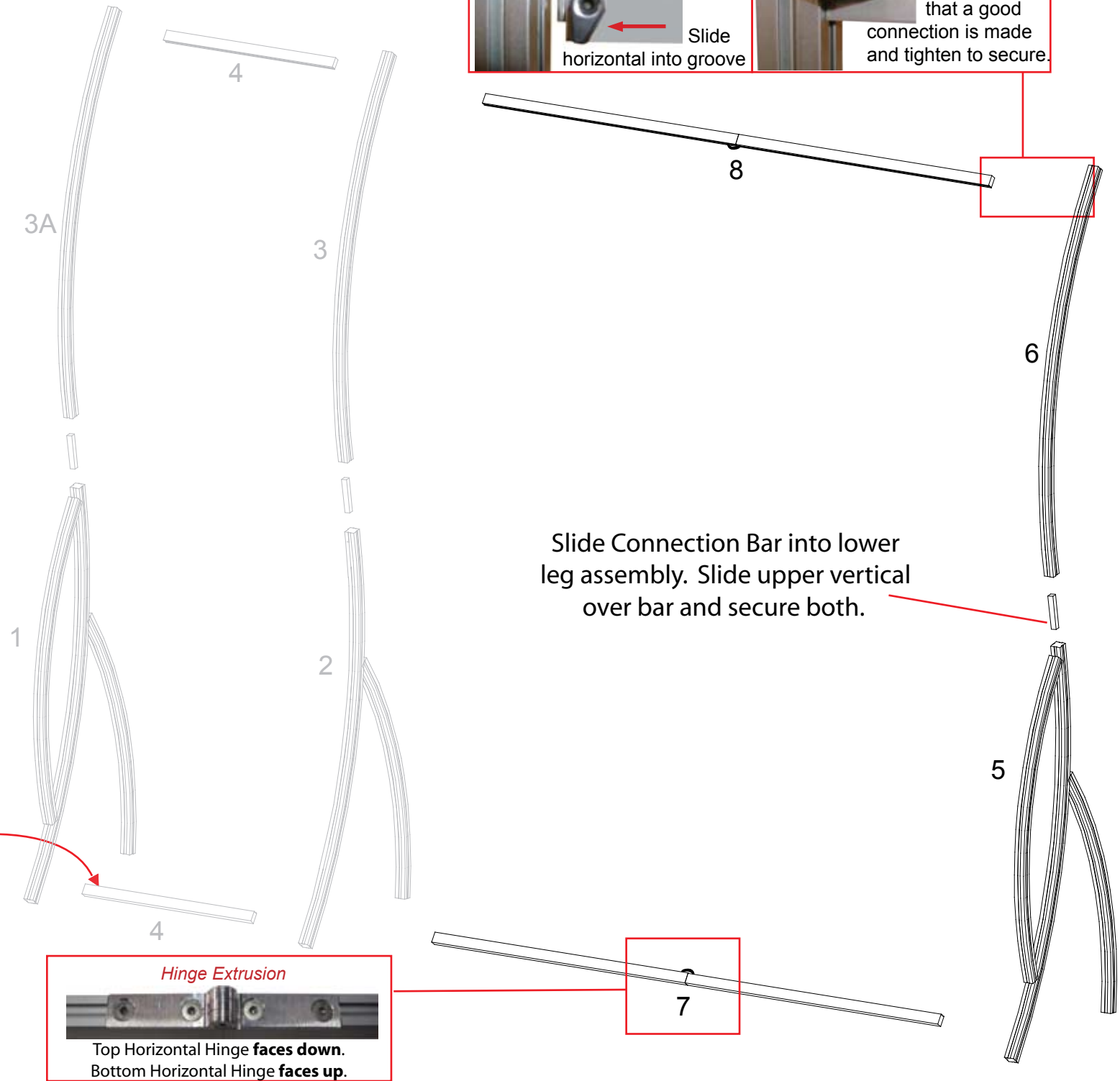

Slide Connection Bar into lower leg assembly. Slide upper vertical over bar and secure both.

Rear View of Display

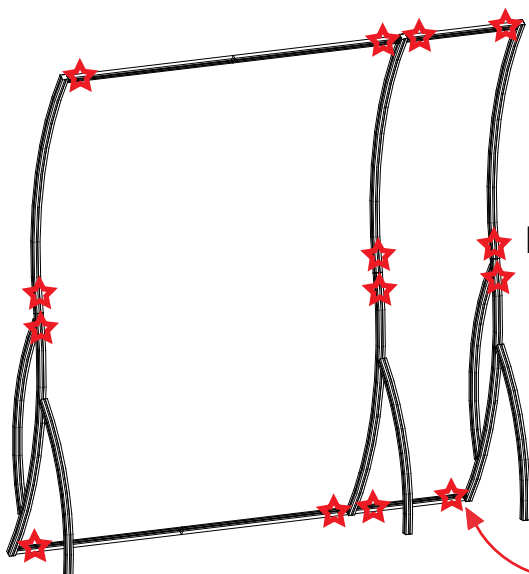

STAR indicates location of knobs on BACKSIDE of unit.

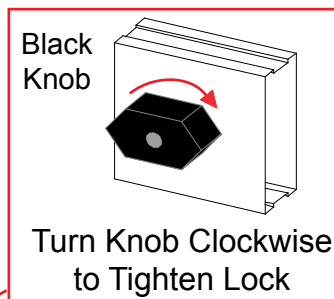

WHEN DISASSEMBLING TIGHTEN ALL BLACK KNOBS TO PREVENT LOSS DURING SHIPPING



Attach decorative wing and blades to A10's attached to Backwall as shown.

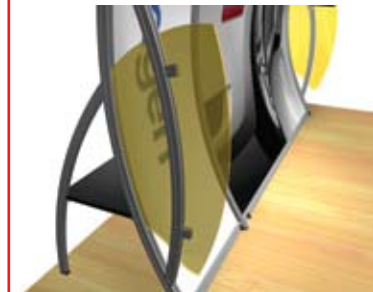

Decorative Blade Attachment (if accidentally removed)
Slide A10 Clamp into groove of square extrusion.



When desired location is found, tighten set screw to secure.

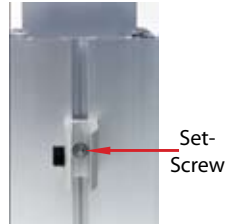

Tighten black plastic set screw to secure Wing in place.

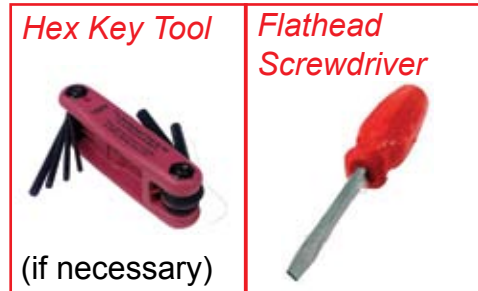
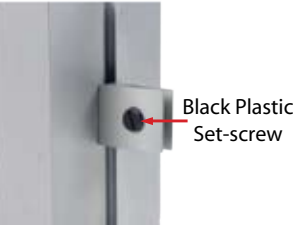

Hex Key Tool

Flathead Screwdriver

(if necessary)

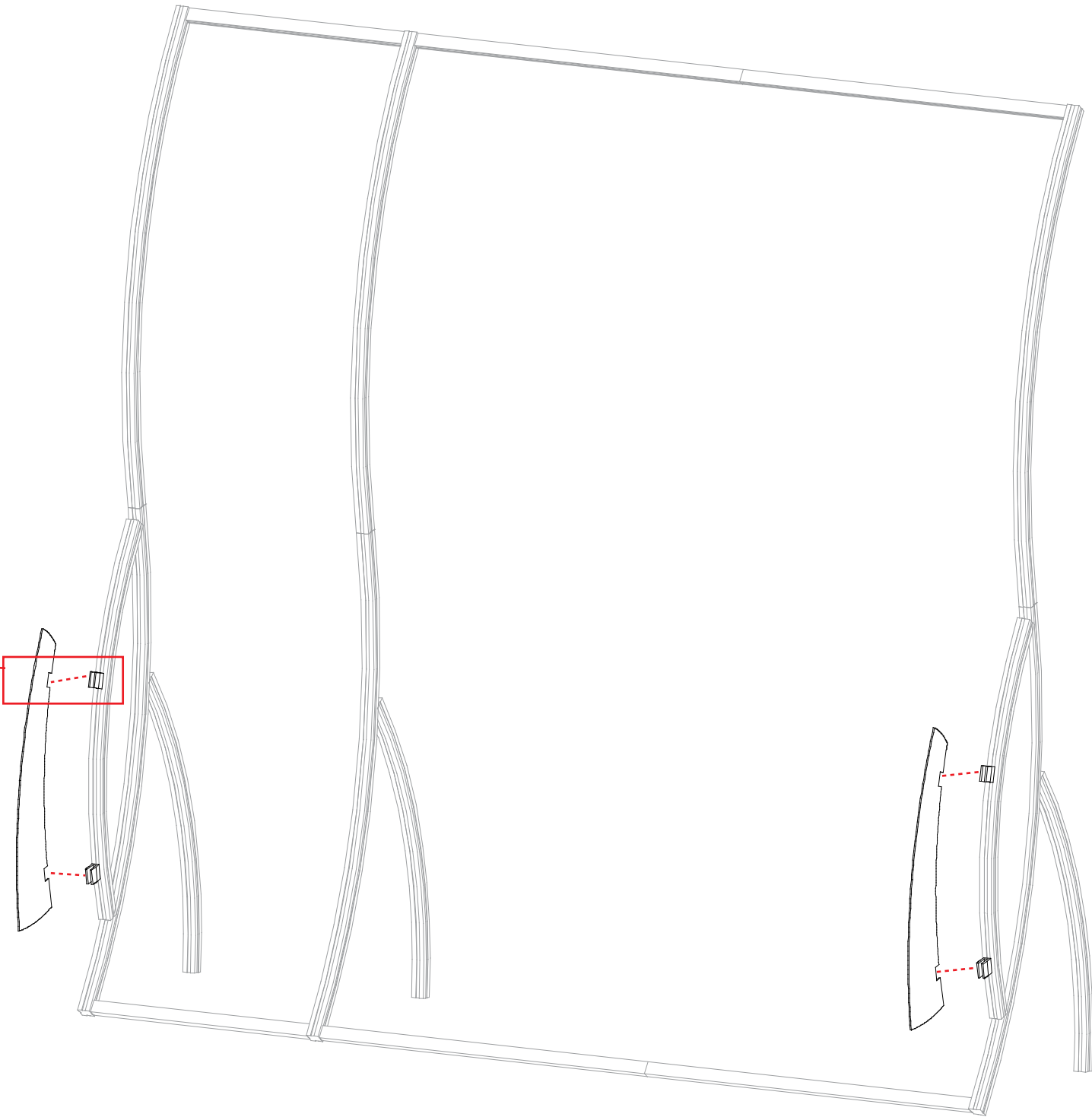

WHEN DISASSEMBLING TIGHTEN ALL BLACK KNOBS TO PREVENT LOSS DURING SHIPPING

866.652.2100

Accessory Attachment
Attach Header support
then Slide header into Groove

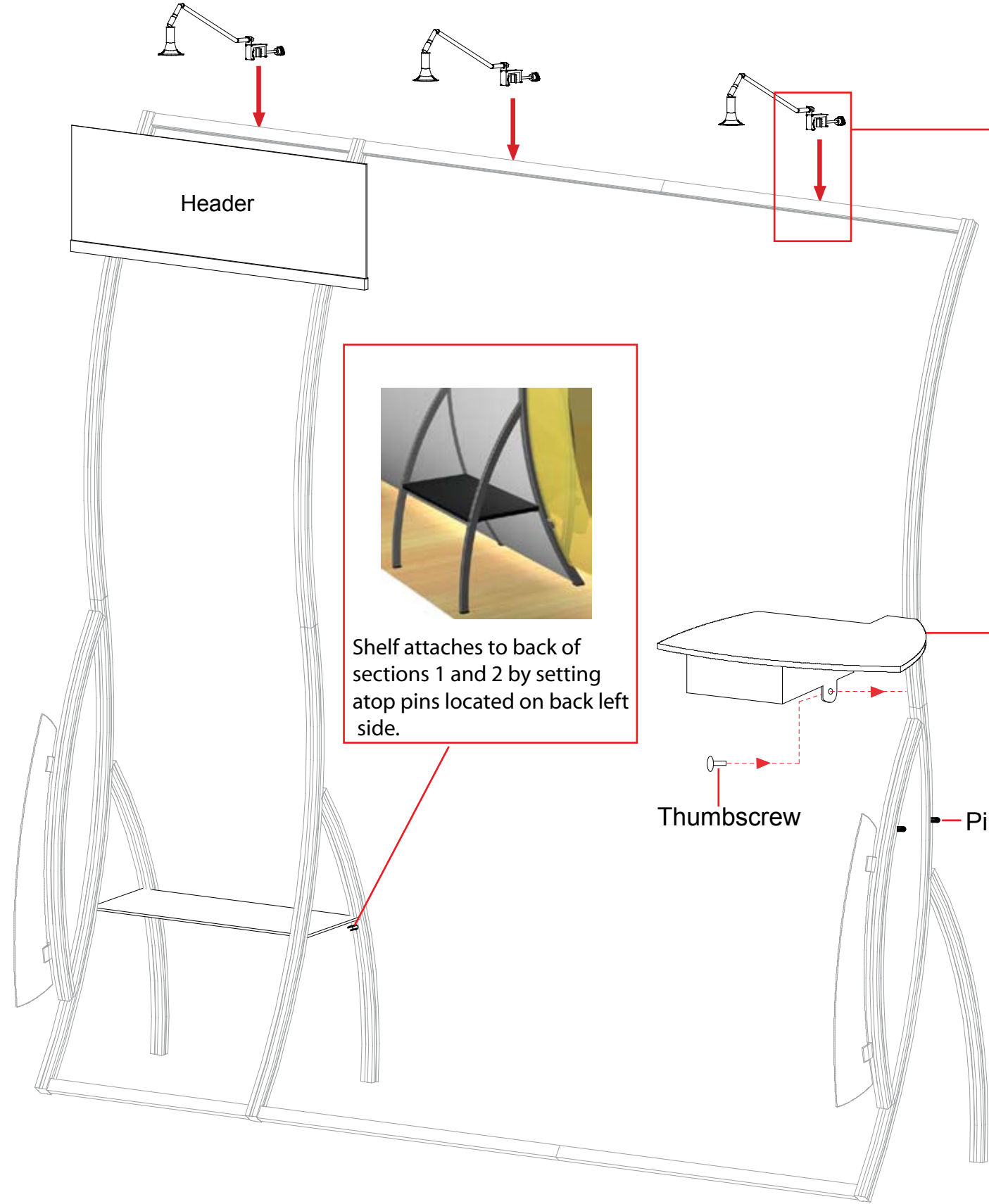
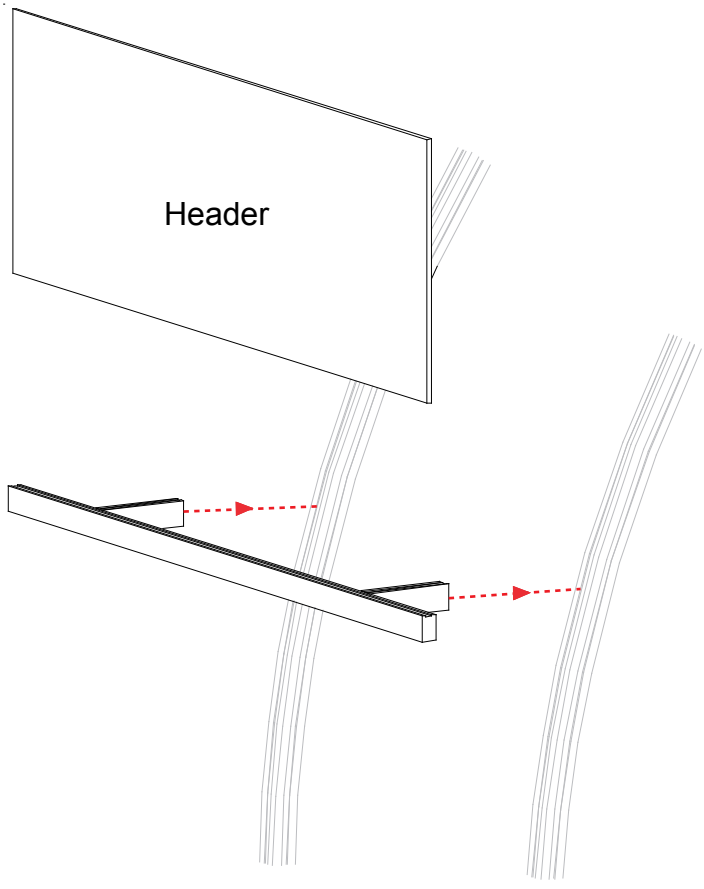

Light Connection
Attach Lights to
Backwall where
desired and tighten
in place.

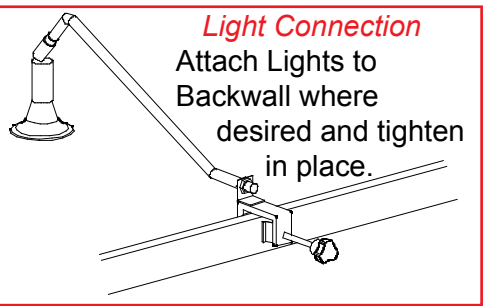

Shelf attaches to back of
sections 1 and 2 by setting
atop pins located on back left
side.



Cubby Attachment
Shelf attaches to section
5 by setting atop pins
located on right side
and securing into place
with thumbscrew on left.



Thumbscrew Pins

Slide onto back pin first.
When attaching counter you will need to first
slide shelf onto back pin then set down on front
pin.



WHEN DISASSEMBLING TIGHTEN ALL BLACK KNOBS TO PREVENT LOSS DURING SHIPPING

866.652.2100

| Part Number | Qty | Description |
|-------------|-----|--------------------------------------|
| 17 | 1 | 30"h Corner Extrusion w/ Door Hinges |
| 18 | 1 | 30"h Corner Extrusion |
| 19 | 1 | 30"h Corner Extrusion |
| 20 | 1 | 30"h Corner Extrusion w/ Door Stop |
| 21/21a | 4/2 | 11"w Horizontal Extrusion |
| 22 | 2 | 18.534"w Horizontal Extrusion |
| 23 | 2 | 24.842"w Horizontal Extrusion |

Steps

- 1) Attach horizontal extrusions [21] between corner extrusions [17&18 and 19&20], placing inserts where indicated, see Top View for extrusion orientation.
- 2) Attach horizontal extrusions [23] between corner extrusions [18 and 19], placing insert between horizontals as shown.

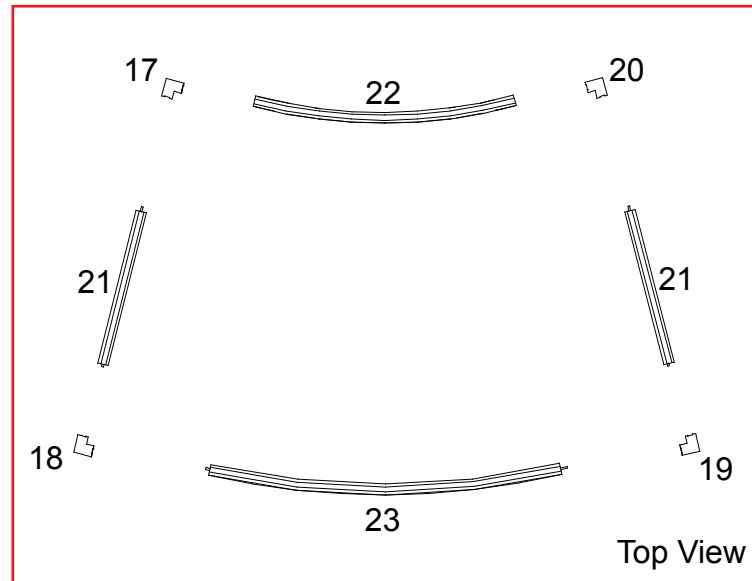

Top View

Steps (Cont'd):

- 3) Attach curved horizontal extrusions [22] between corner extrusions [17 and 20], attaching door between curved horizontals, see Door Attachment details.
- 4) Place hooks onto horizontal extrusions where indicated, see Hook Attachment detail.
- 5) Set shelf atop hooks.
- 6) Set counter top atop assembled base and secure inside of counter top with thumbscrews

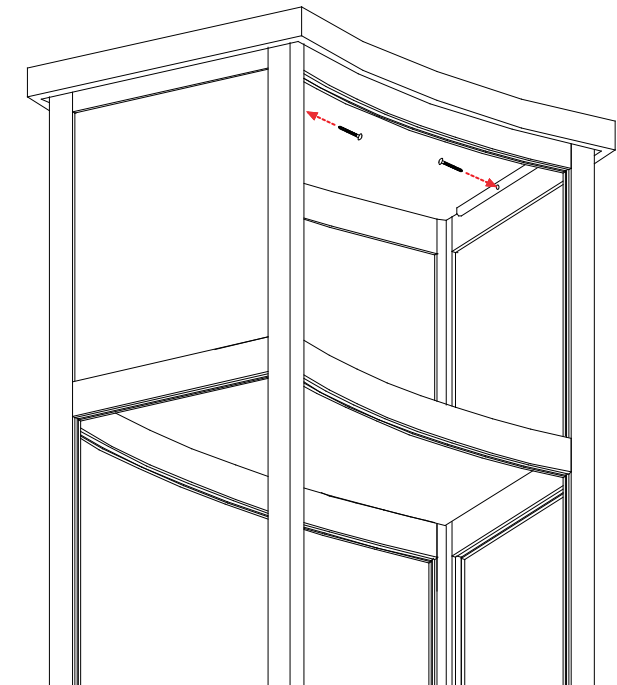
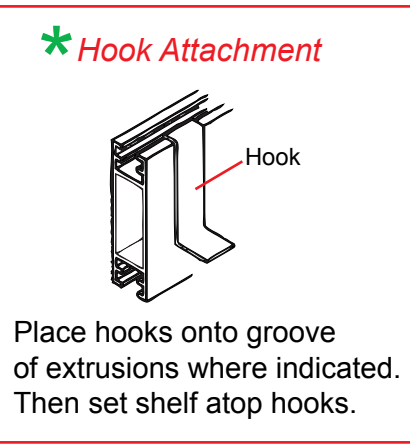
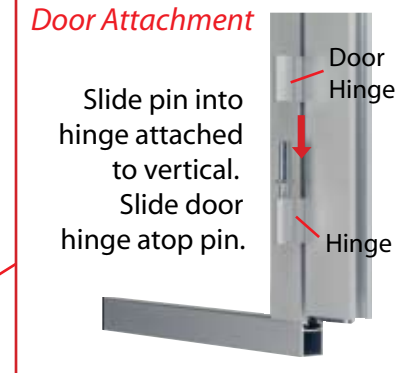
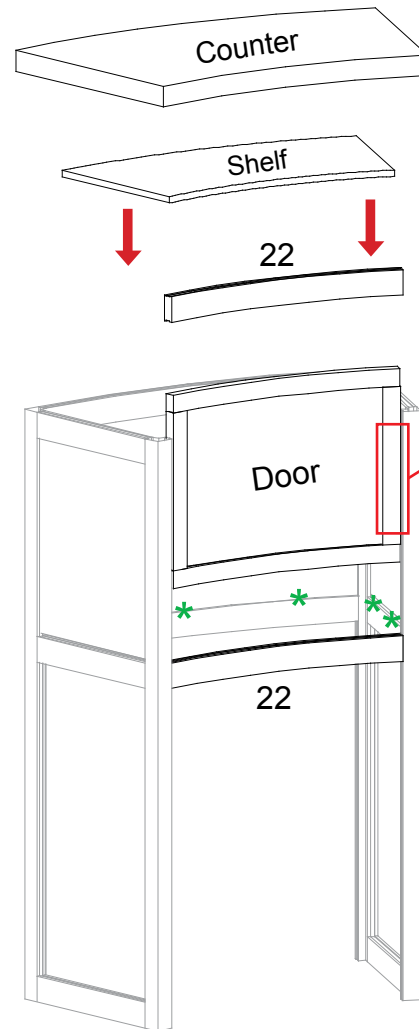
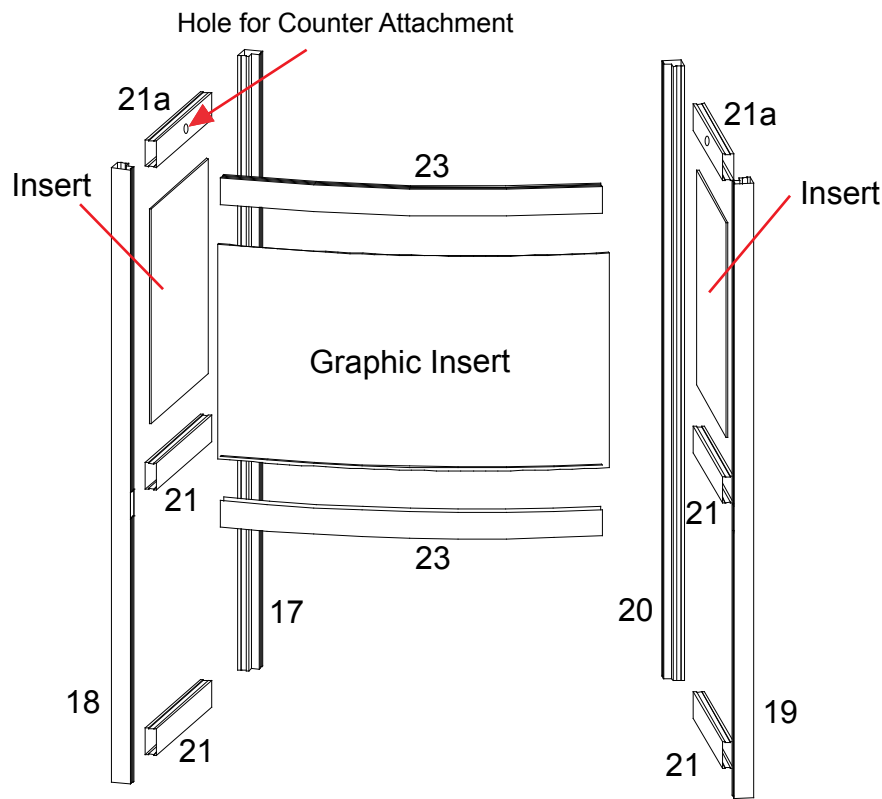
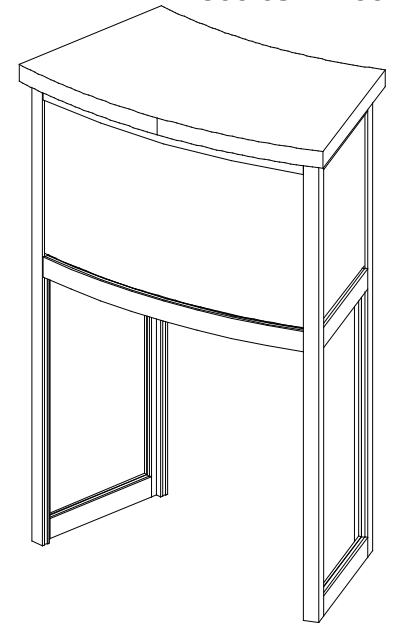

Use door opening to secure counter top using thumbscrews provided.

WHEN DISASSEMBLING TIGHTEN ALL BLACK KNOBS TO PREVENT LOSS DURING SHIPPING

866.652.2100

LT Panel - Part List

| Item Number | Description |
|-------------|--|
| 1 | 23" w x 42" h Flat Panel w/ Door |
| 2 | 42" h 90° Corner Connector |
| 3 | 23" w x 42" h Flat Panel |
| 4 | 42" h 90° Corner Connector w/ Notch for Hook |
| 5 | 23" w x 42" h Flat Panel |
| 6 | 42" h 90° Corner Connector w/ Notch for Hook |
| 7 | 23" w x 42" h Flat Panel |
| 8 | 42" h 90° Corner Connector |

Modul Extrusion - Part List

| Item Number | Description |
|-------------|-------------------------------|
| 1 | 44.423" Formed Extrusion |
| 2 | 44.423" Formed Extrusion |
| 3 | 22.23" w Horizontal Extrusion |
| 4 | 22.23" w Horizontal Extrusion |

Steps:

- 1) Assemble pedestal base by starting at panel #1 and continue in numerical order.
- 2) Velcro internal shelf supports to inside of assembled LT base.
- 3) Set internal shelf atop supports.

Steps:

- 4) Connect extrusions 1 thru 4 together.
- 5) Apply graphic to assembled frame.
- 6) Hook assembled frame with graphic attached to assembled Pedestal as shown.

Steps:

- 7) Place Counter atop Assembled Pedestal.

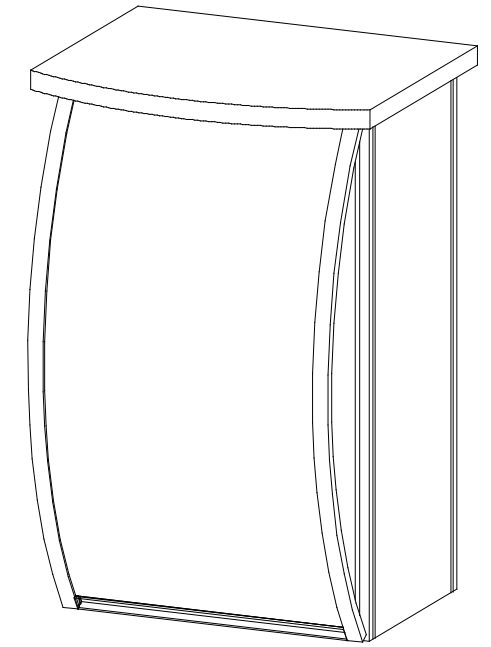
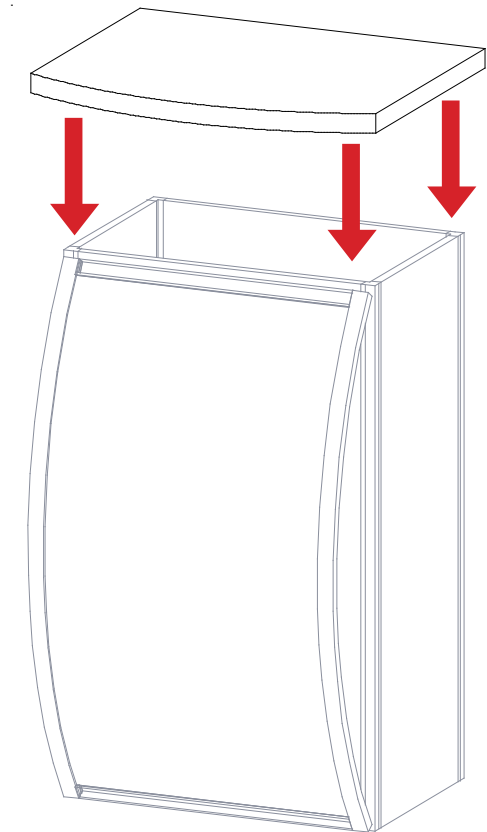
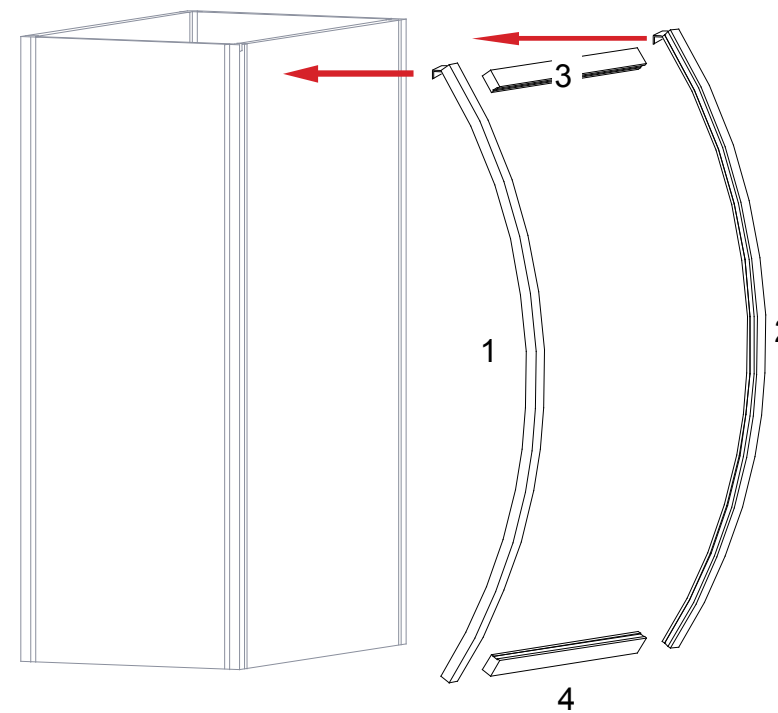
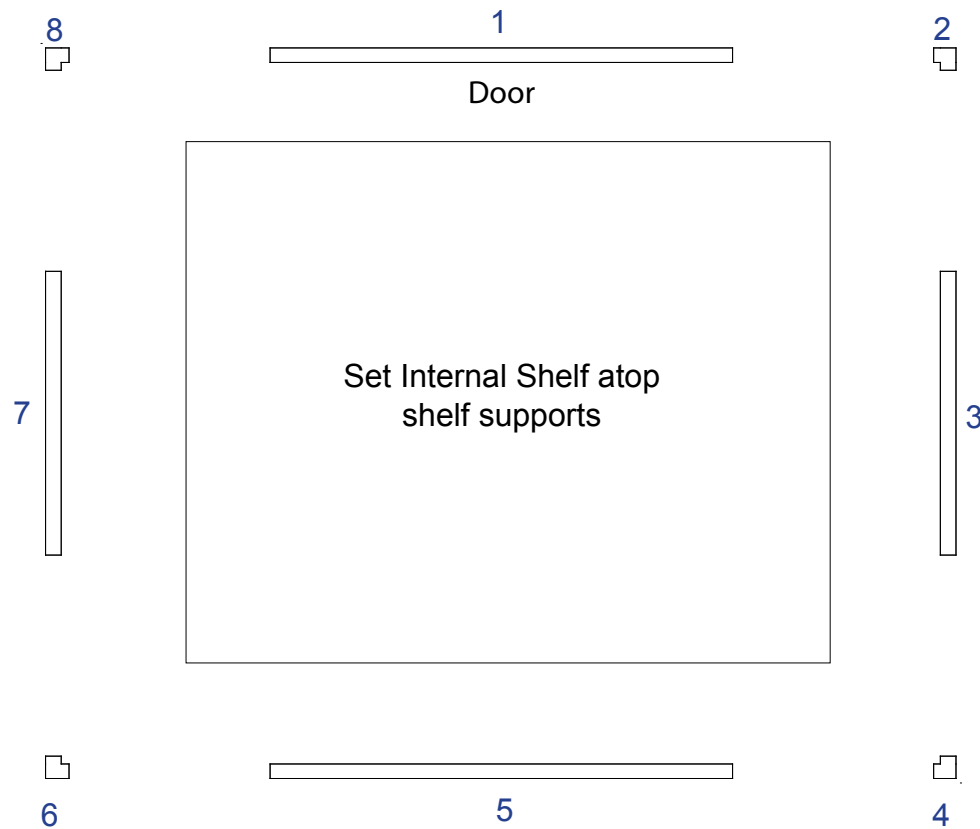

WHEN DISASSEMBLING TIGHTEN ALL BLACK KNOBS TO PREVENT LOSS DURING SHIPPING

Case #1 - Backwall Components

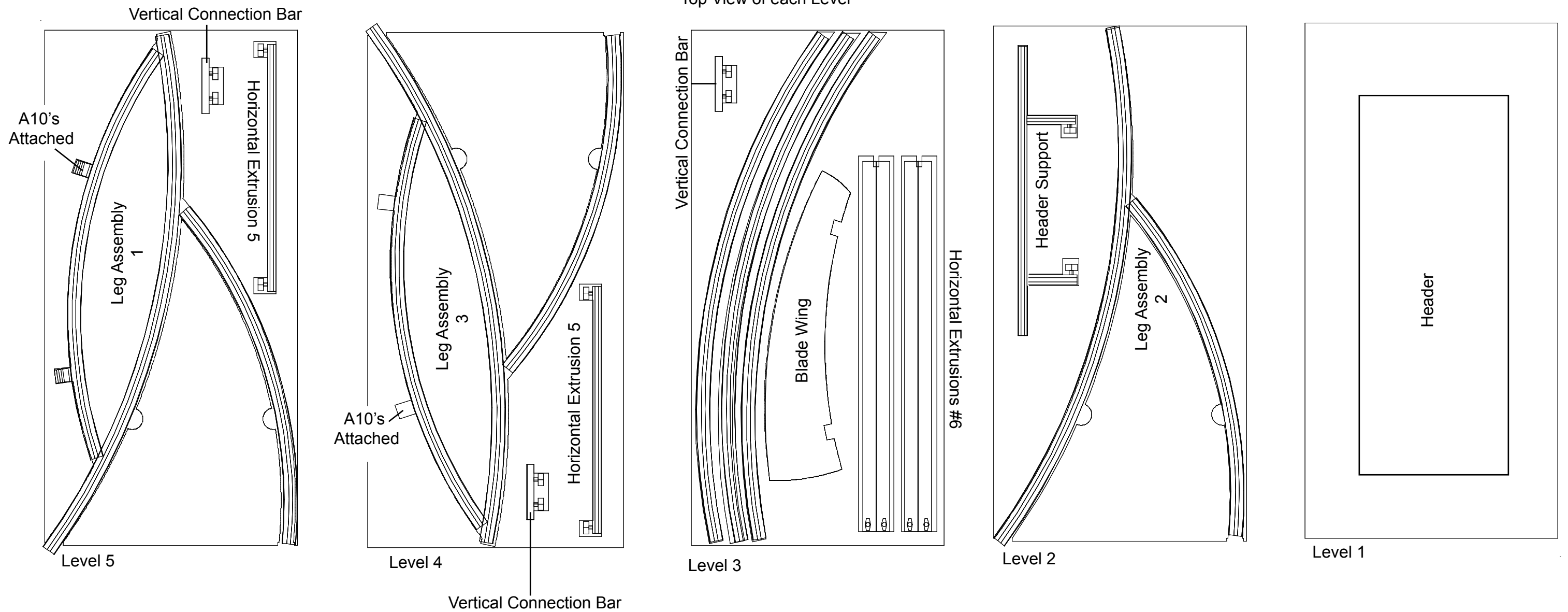

WHEN DISASSEMBLING TIGHTEN ALL BLACK KNOBS TO PREVENT LOSS DURING SHIPPING

Case #2 - Backwall Components

Top View of each Level

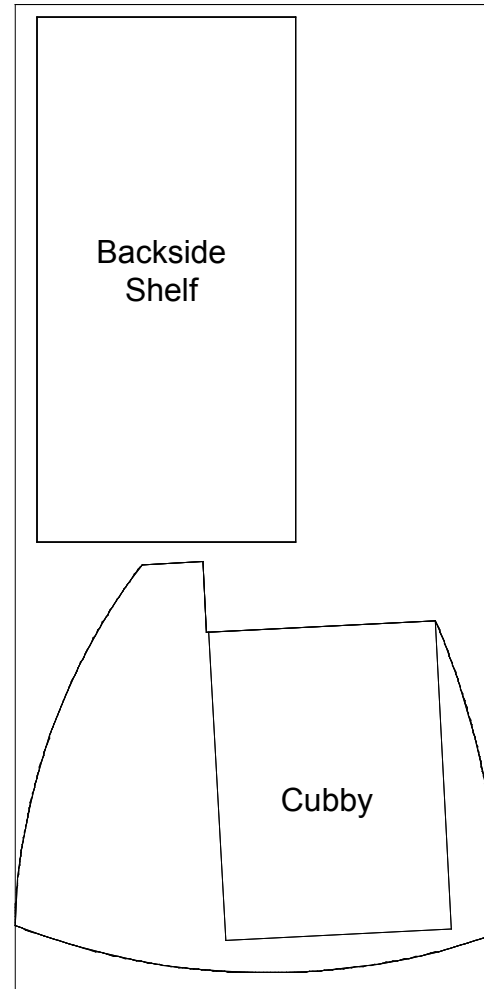

Level 1

WHEN DISASSEMBLING TIGHTEN ALL BLACK KNOBS TO PREVENT LOSS DURING SHIPPING

Case #3 - Workstation components

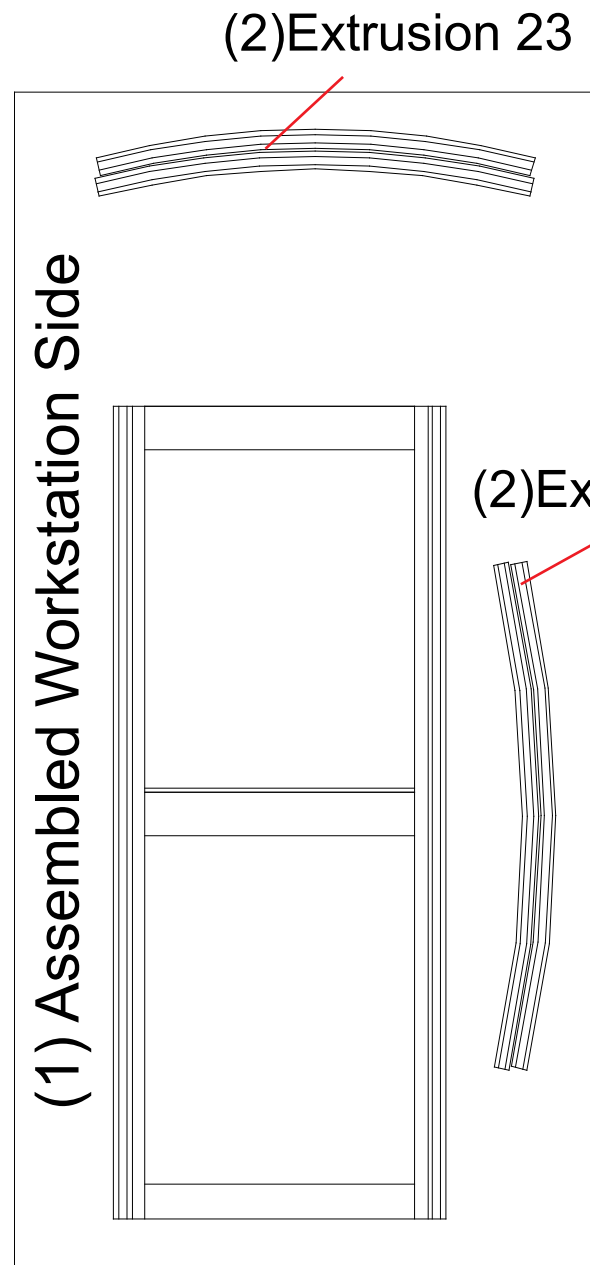

Level 1

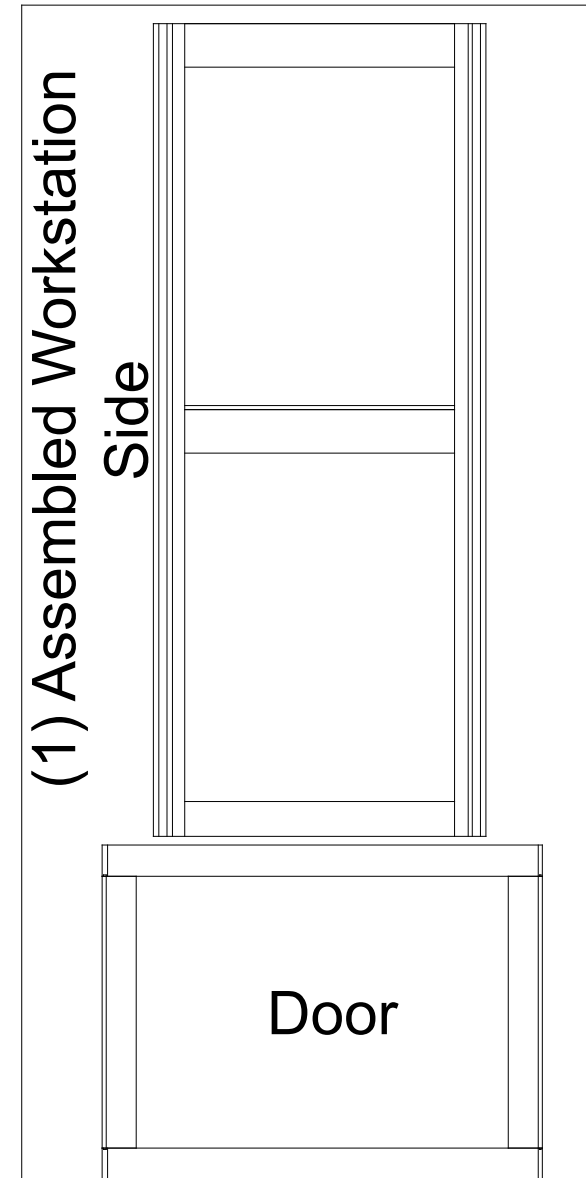

Level 2

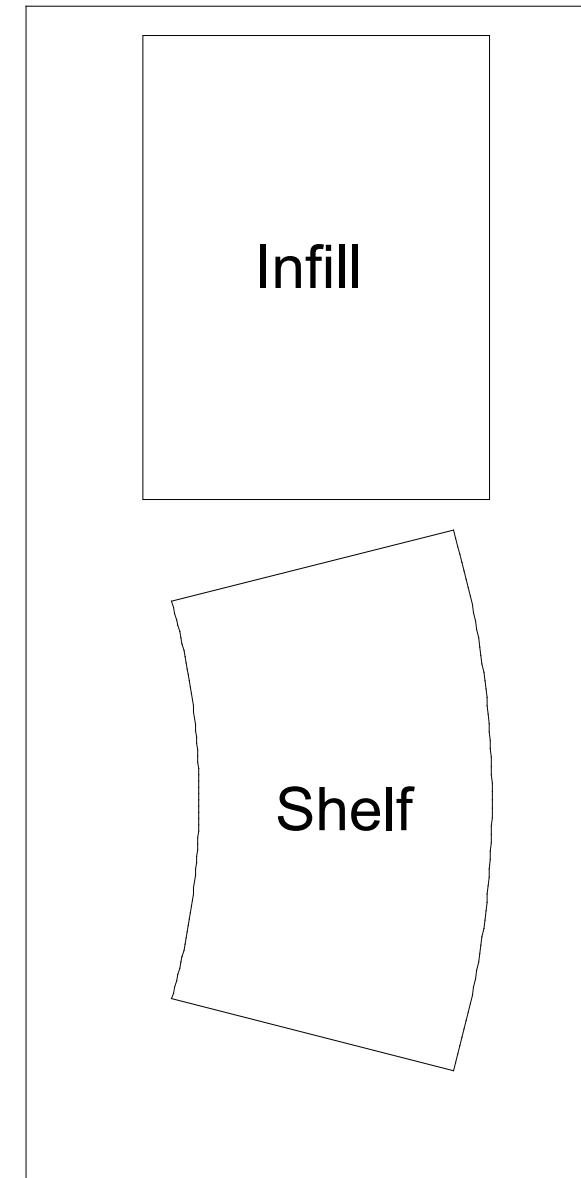

Level 3

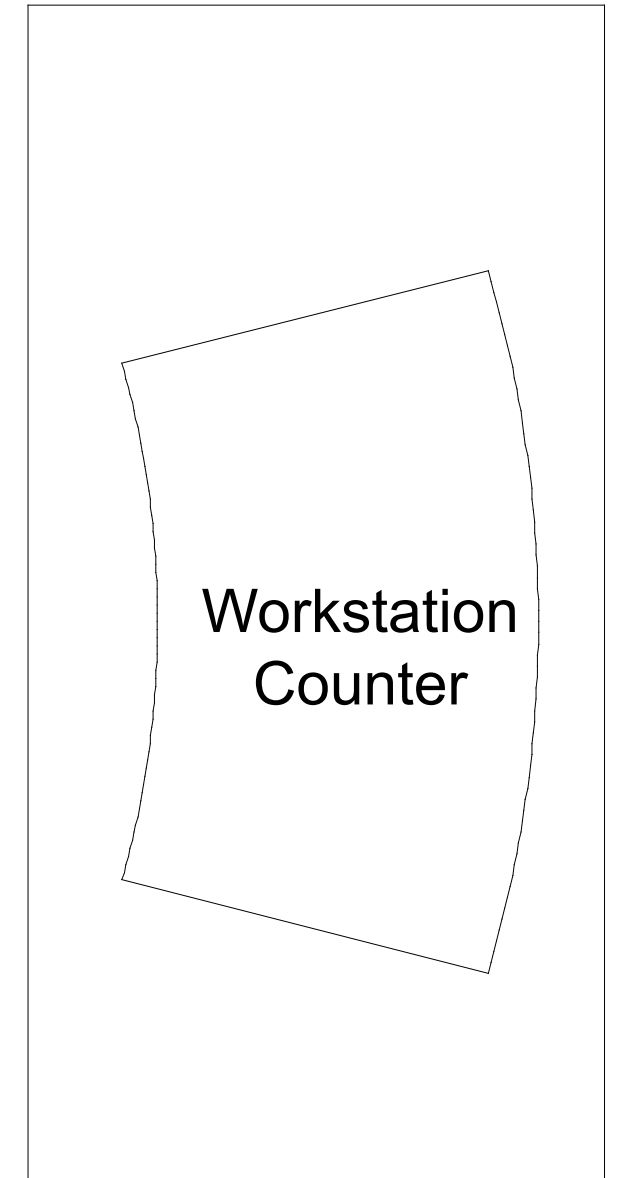

Level 4

WHEN DISASSEMBLING TIGHTEN ALL BLACK KNOBS TO PREVENT LOSS DURING SHIPPING

Case #4 - Pedestal

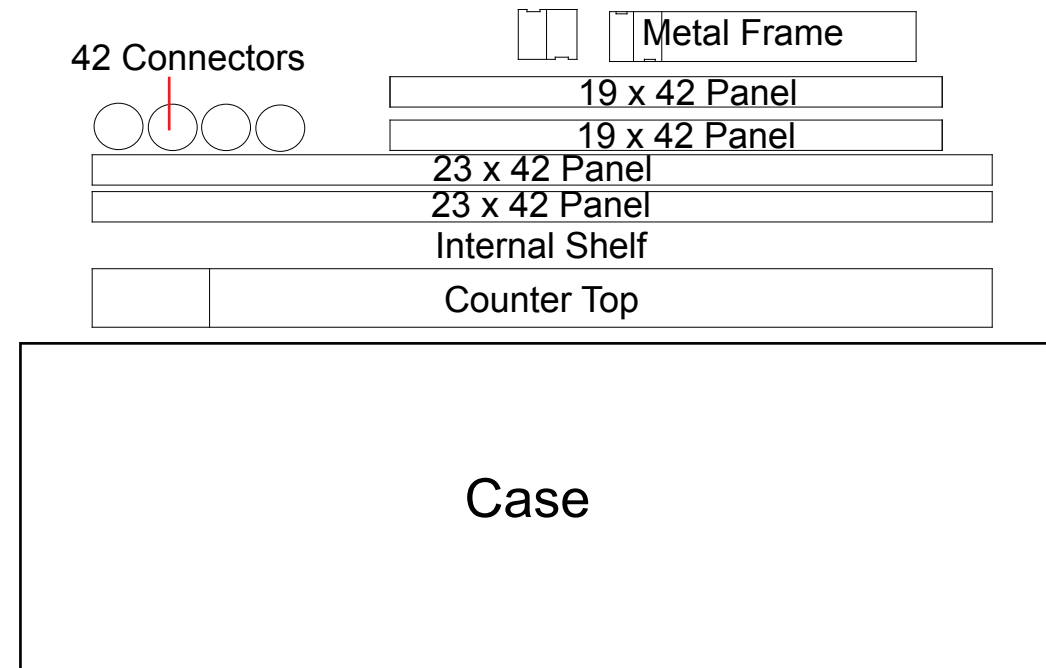

WHEN DISASSEMBLING TIGHTEN ALL BLACK KNOBS TO PREVENT LOSS DURING SHIPPING