

euro It | *HYBRIDS*

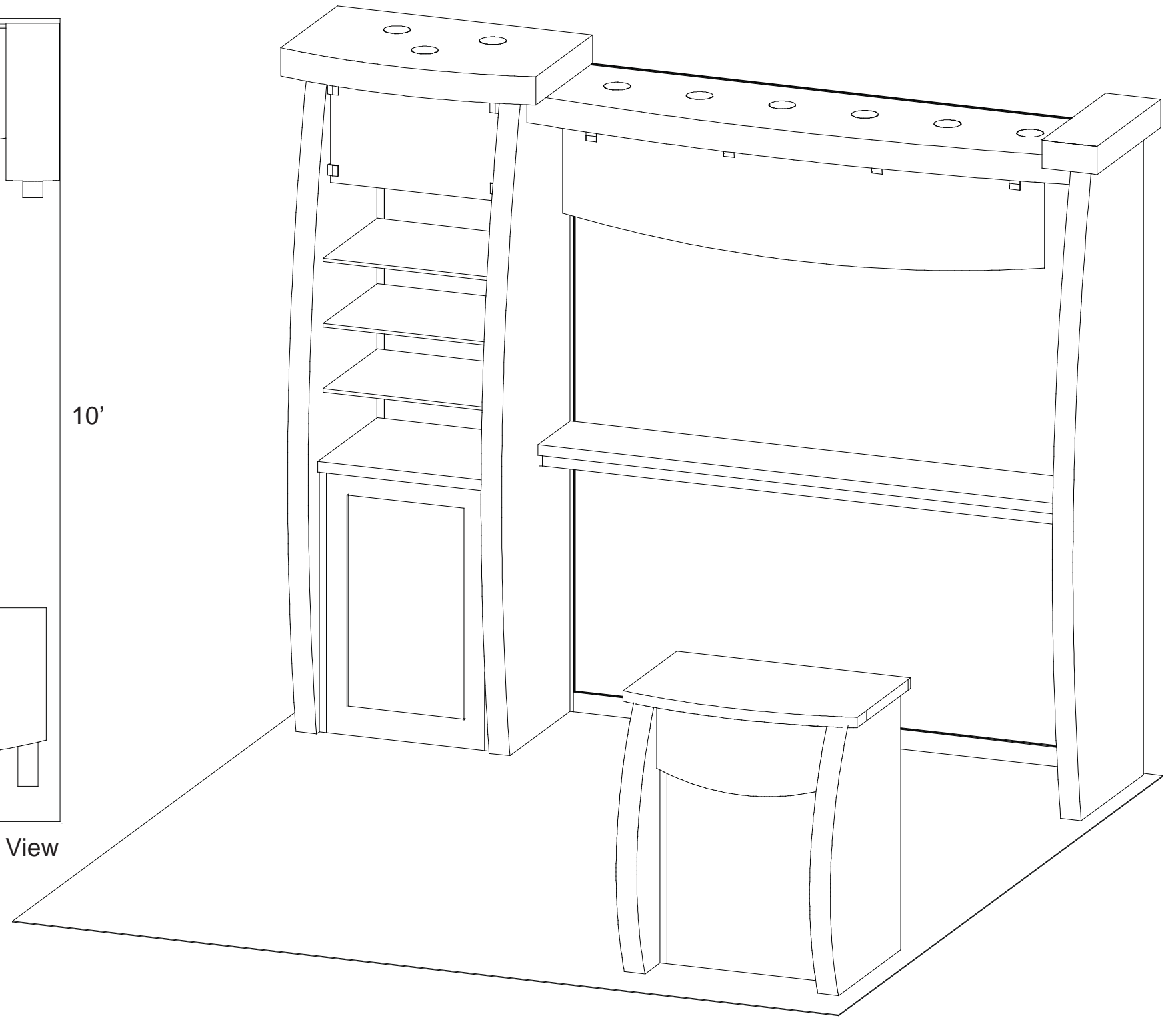
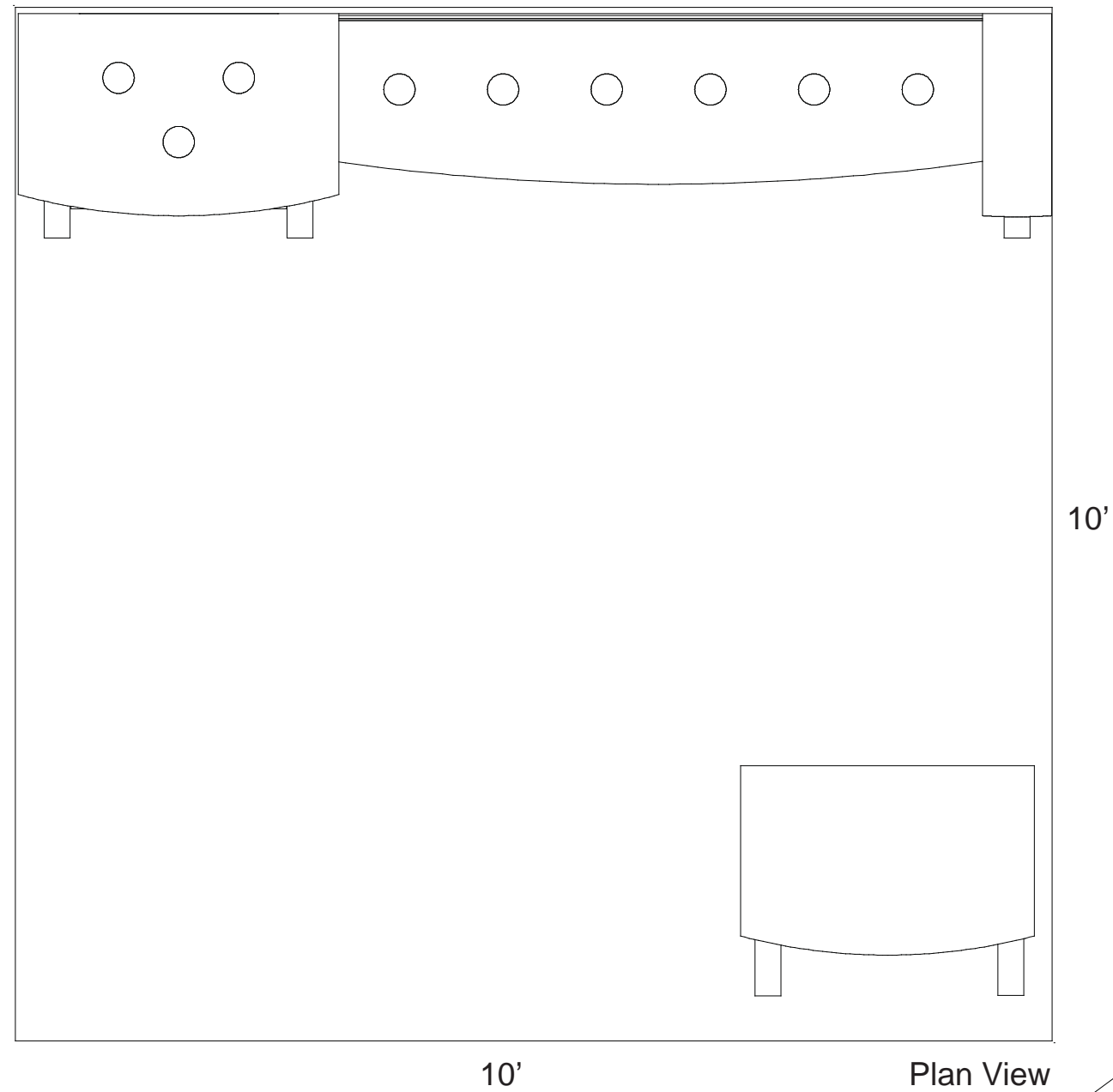

WHEN DISASSEMBLING ALUMINUM EXTRUSION, TIGHTEN ALL SETSCREWS AND LOCKS TO PREVENT LOSS DURING SHIPPING

euro lt | HYBRIDS

Using Your Setup Instructions

The Euro LT Hybrids Setup Instructions are created specifically for your configuration. They are laid out sequentially in levels, including exploded views, and a logical series of detailed steps to assemble the main structure and components. We encourage you to study the instructions **before** attempting to assemble your exhibit.

Each page reminds you to tighten the setscrews after disassembling your exhibit to prevent loss of the locks and setscrews (see below in RED). This is VERY IMPORTANT.

Cleaning and Packing Your Display

- 1) Use care when cleaning aluminum extrusion or acrylic inserts. Use only non-abrasive cleaners.
- 2) When cleaning laminate inserts, countertops, or panels use mild cleansers and a soft material such as cotton.
- 3) Keep all display components away from extreme heat and long exposure to sunlight to avoid warping and fading.
- 4) Retain all packing material. It will make re-packing much easier and will reduce the likelihood of shipping damage.

General Setup Instructions for Extrusion System



Most exhibits can be assembled with the supplied Hex Key Tool. Occasionally, a flat head screwdriver may be required.



Most horizontal extrusion connections have a patented expandable lock. This lock inserts into the groove of an opposing extrusion. Tightening the lock with the Hex Key Tool expands the lock and creates a strong positive connection.

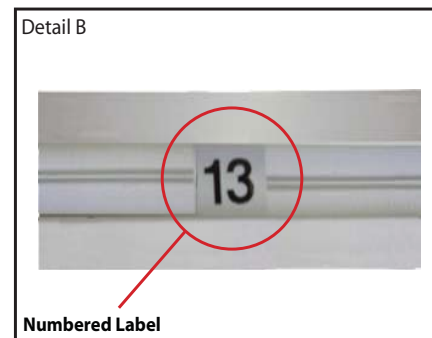

Each extrusion contains a numbered label which corresponds with setup instructions. The label is located within a groove of the extrusion (when possible). With extrusion components the labels contain Black numbers unless otherwise specified.



Remove only (1) setscrew when disassembling. Replace setscrew in extrusion after assembling it. Before packing, replace setscrew in extrusion to avoid losing it.

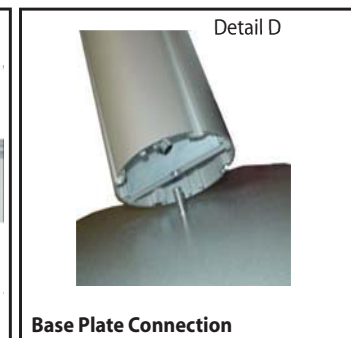

Attach base plate to round or square vertical extrusion using the bolt provided. Be careful not to strip the threads.

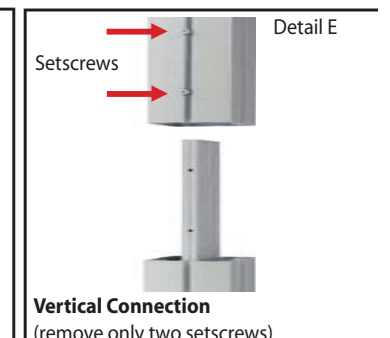

When vertical extrusions are packed in portable cases rather than crates or tubs, they must be broken down into smaller section which then require assembly.

Remove only (2) setscrews when disassembling. Replace setscrews in extrusion after assembling it. Before packing, replace setscrews in extrusion to avoid losing them.

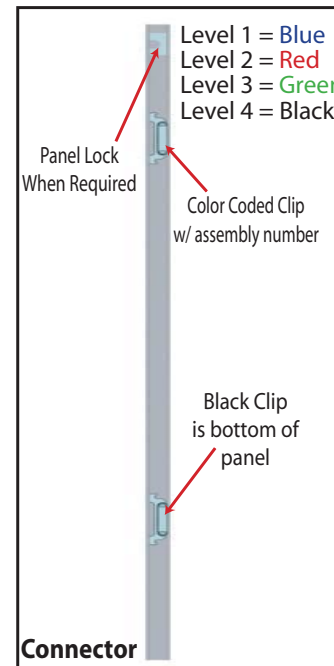

Each component has 2 clips, the lower clip is ALWAYS black. The top clip is color coded to distinguish which level. The color coded clip also contains the numbered label.

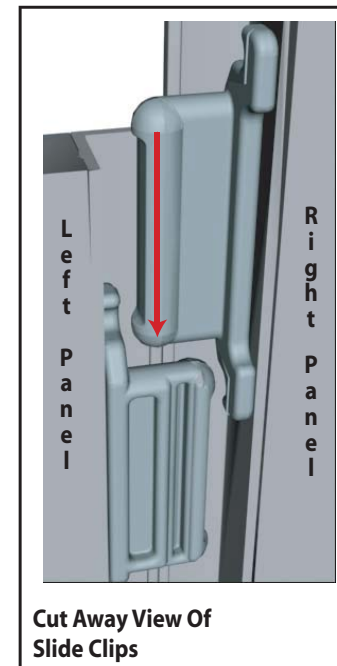

Components connect together by aligning them and sliding downward connecting clips together.

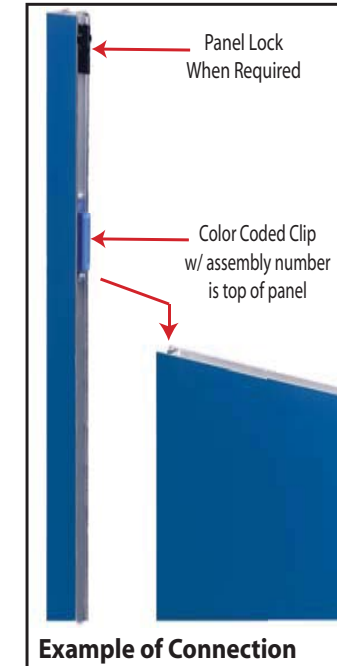

Configurations are assembled from left to right, usually starting with #1 and following the numbered sequence.

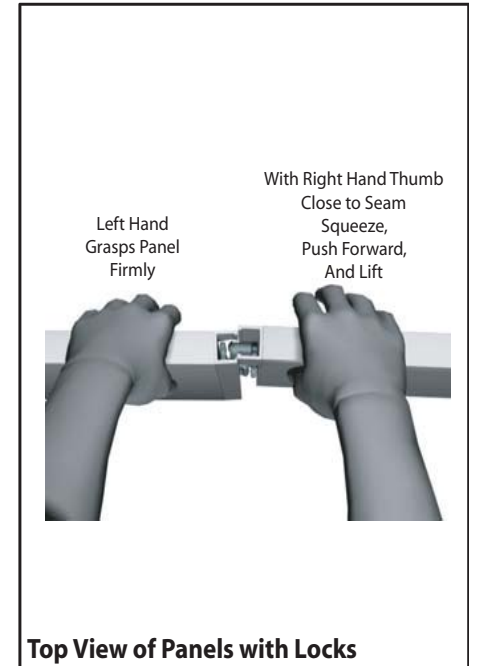

The first level of components contain panel locks that are located at the top of the panel for extra stability and seamless connection. When disassembling panels twist top connection slightly and lift right panel upward.

WHEN DISASSEMBLING ALUMINUM EXTRUSION, TIGHTEN ALL SETSCREWS AND LOCKS TO PREVENT LOSS DURING SHIPPING

EURO LT: Panel System - Level 1

Item Number	Description
1	23"w x 46"h Flat Panel w/ Door
2	23"w x 46"h Flat Panel

Steps:

- 1) Connect panels [1 and 2] between connectors on wooden pillars as shown.
- 2) Connect panel [2] between connectors and atop panel [2].
- 3) Velcro shelf supports to inside of assembled section where indicated.
- 4) Set counter top atop assembled base.

EURO LT: Panel System - Level 2

Item Number	Description
2	23"w x 46"h Flat Panel

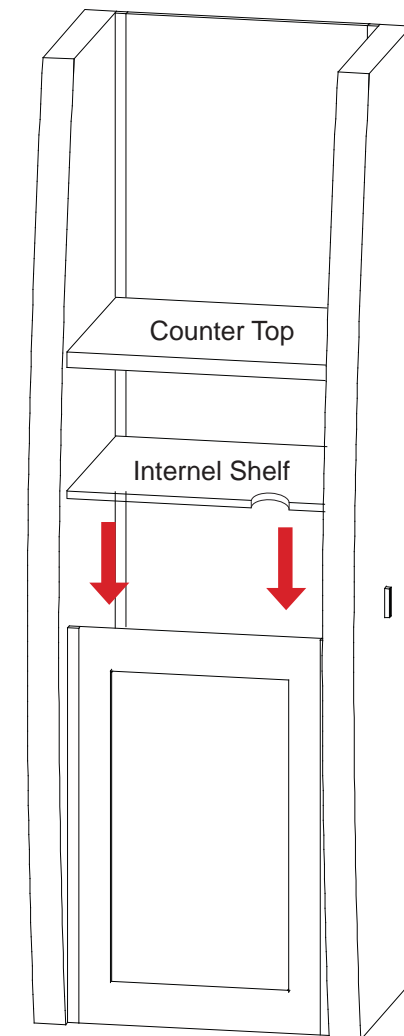
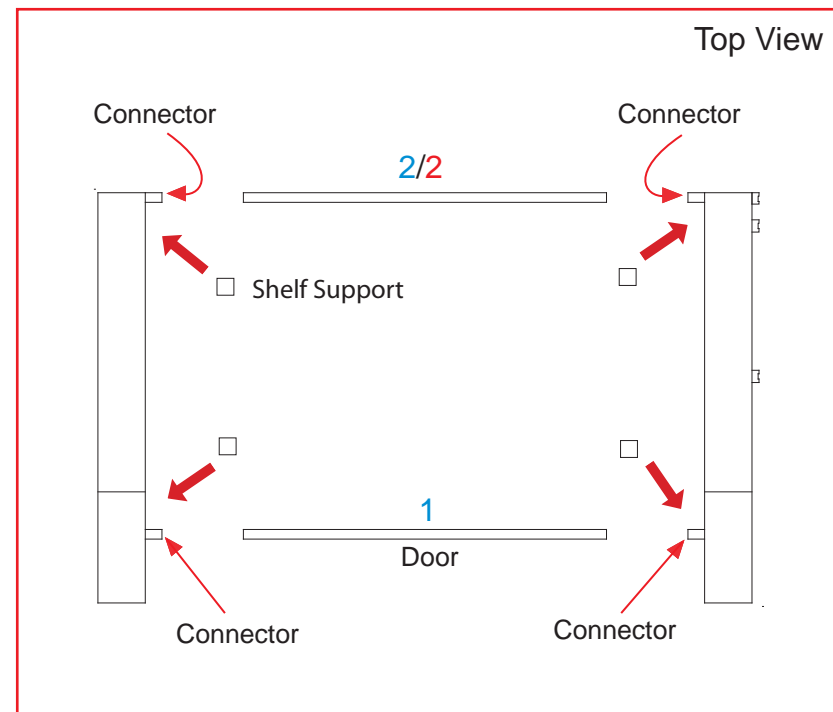
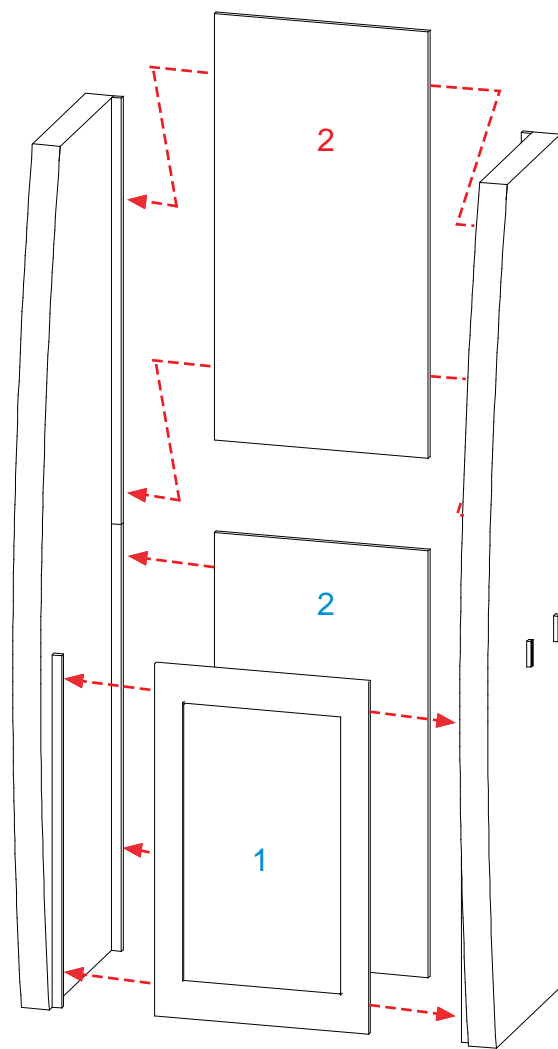

WHEN DISASSEMBLING ALUMINUM EXTRUSION, TIGHTEN ALL SETSCREWS AND LOCKS TO PREVENT LOSS DURING SHIPPING

866.652.2100

Part Number	Qty	Description
1	1	79.095"w Horizontal Extrusion
2	1	79.095"w Horizontal Extrusion
3	1	79.095"w Horizontal Extrusion
4	1	79.095"w Horizontal Extrusion

Steps:

- 1) Attach horizontal extrusions [1, 2, 3 and 4] between connectors on wooden pillars as shown.
- 2) Place counter top atop horizontal extrusions [3 and 4].

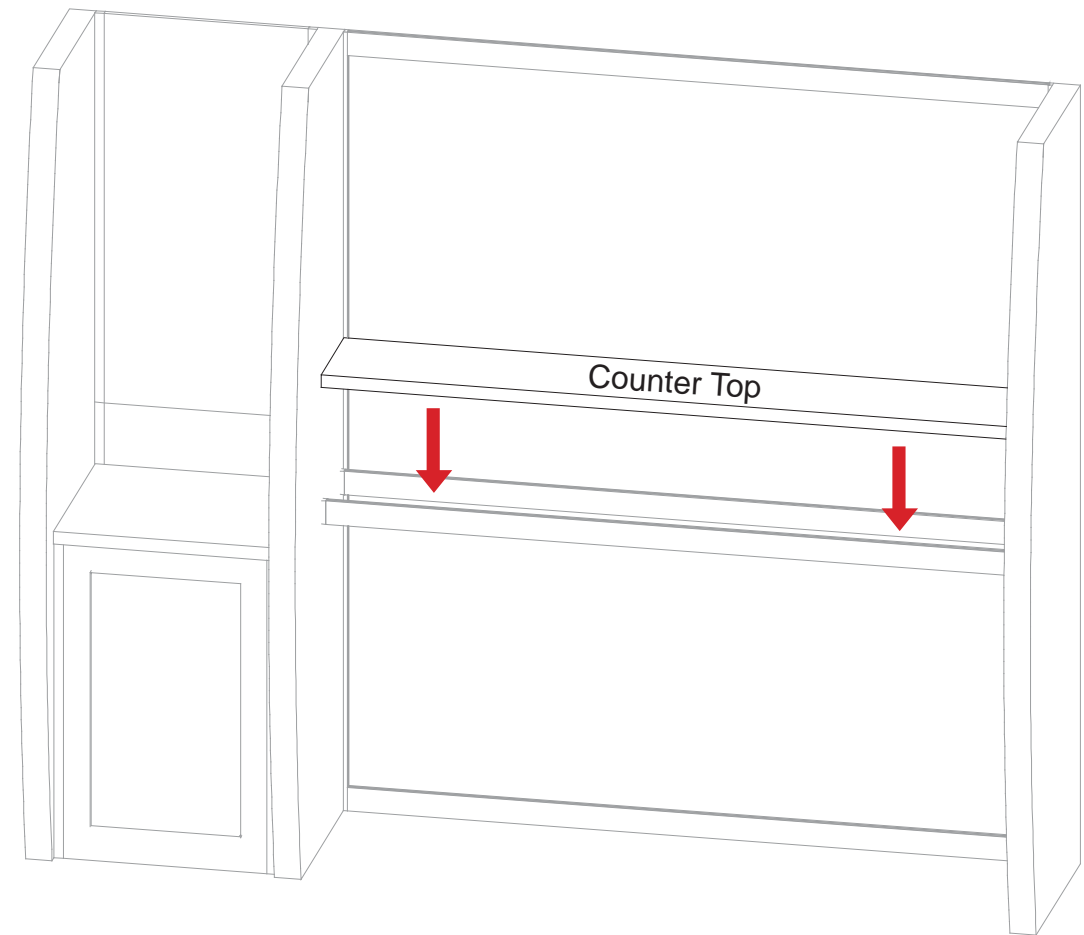
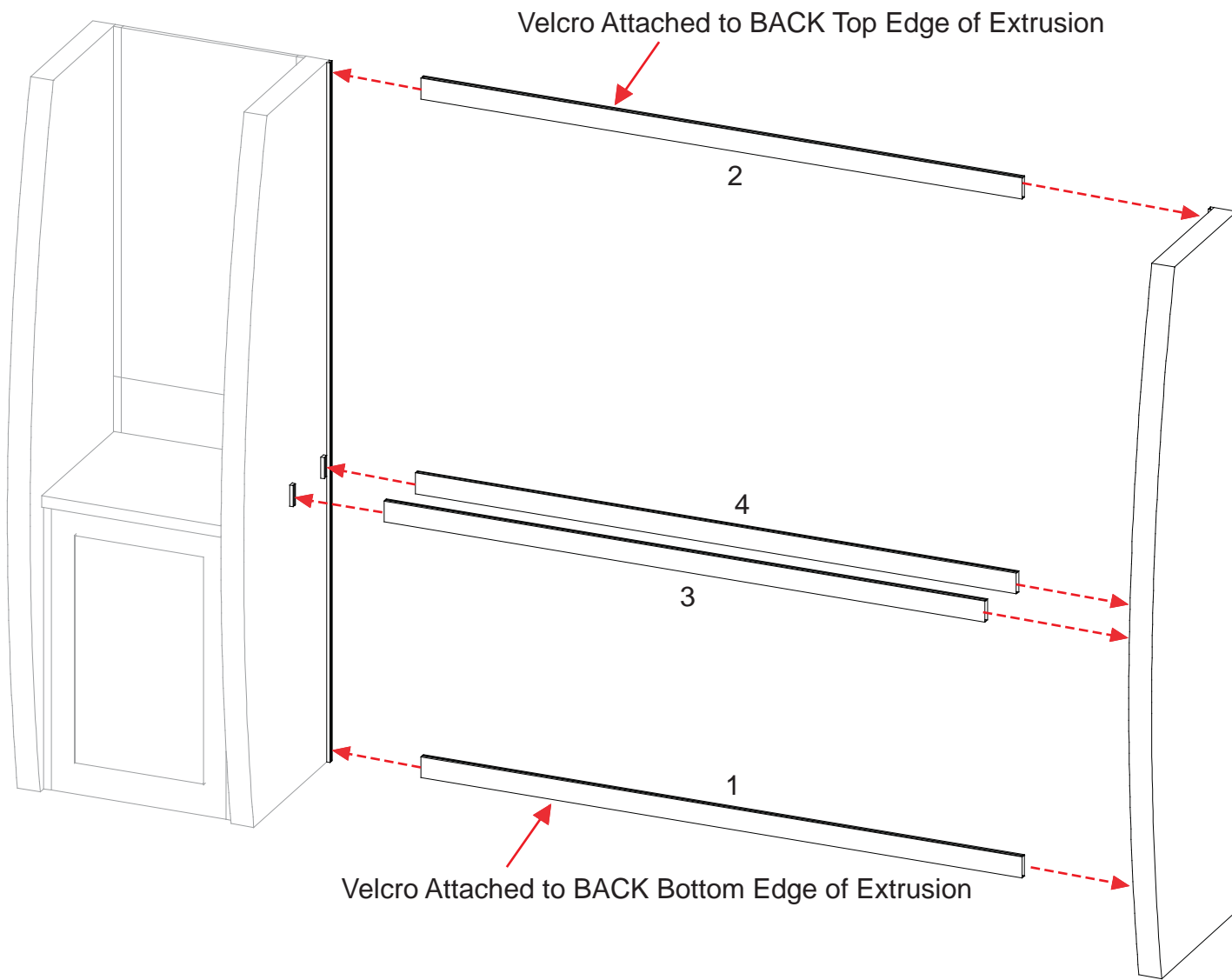

WHEN DISASSEMBLING ALUMINUM EXTRUSION, TIGHTEN ALL SETSCREWS AND LOCKS TO PREVENT LOSS DURING SHIPPING

866.652.2100

Steps:

- 1) Install pins to wooden pillars.
- 2) Set shelves atop pins.
- 3) Attach graphic between uprights using A10 clamps, see Graphic Attachment.
- 4) Hook center ceiling piece to top of backwall and secure with bolts
- 5) Attach small ceiling to top of wooden pillars using bolts.
- 6) Attach graphic to ceiling using a10 clamps.

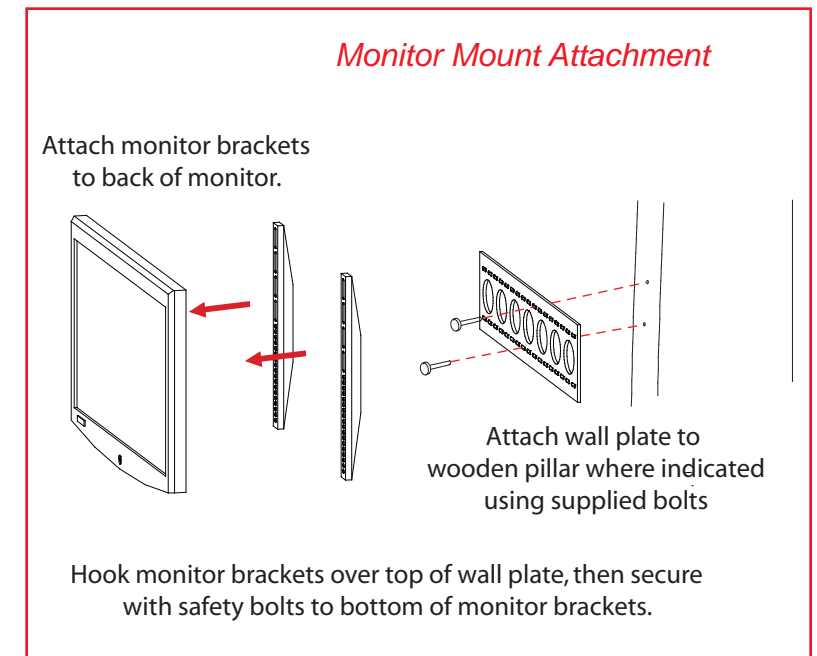
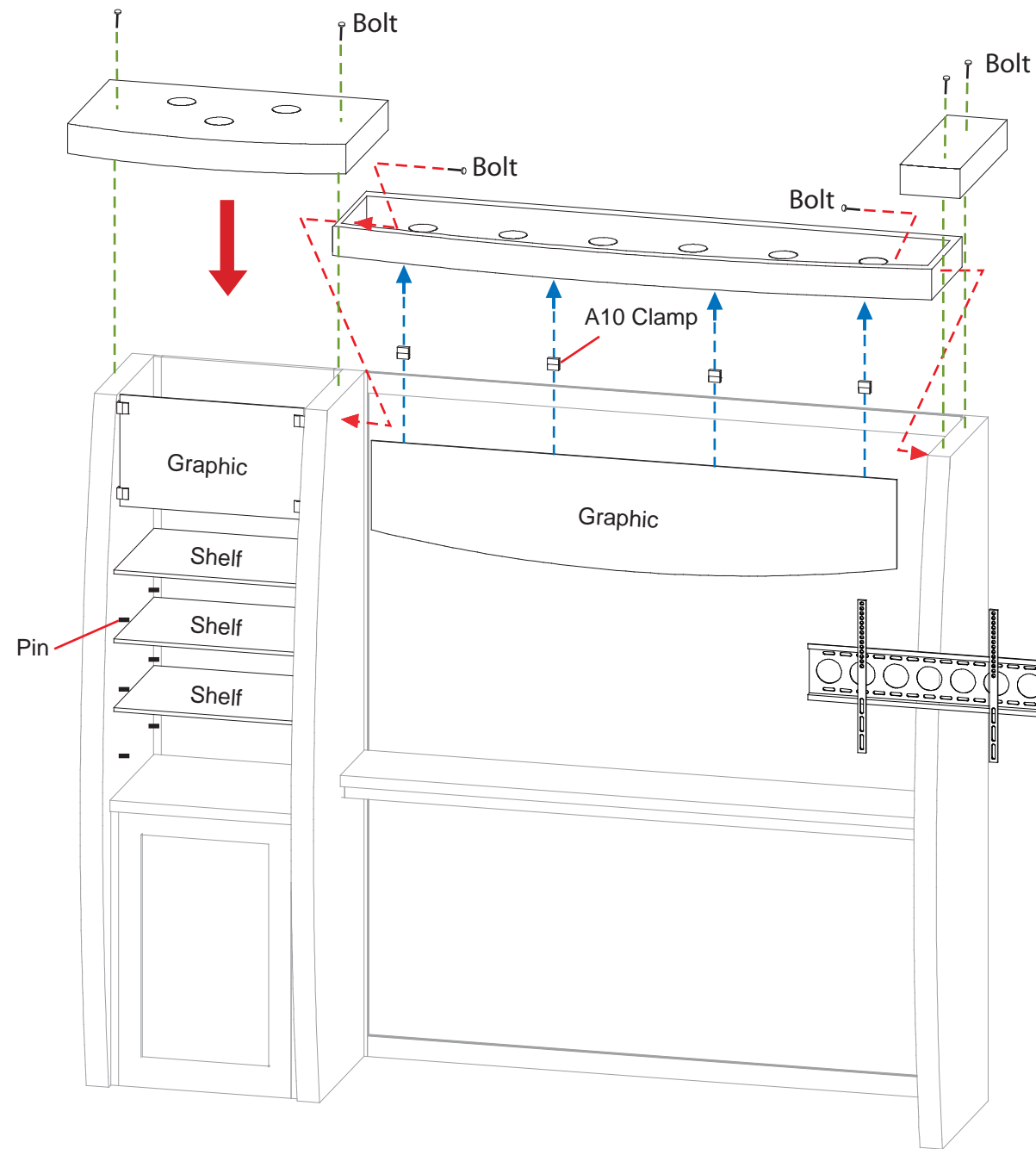
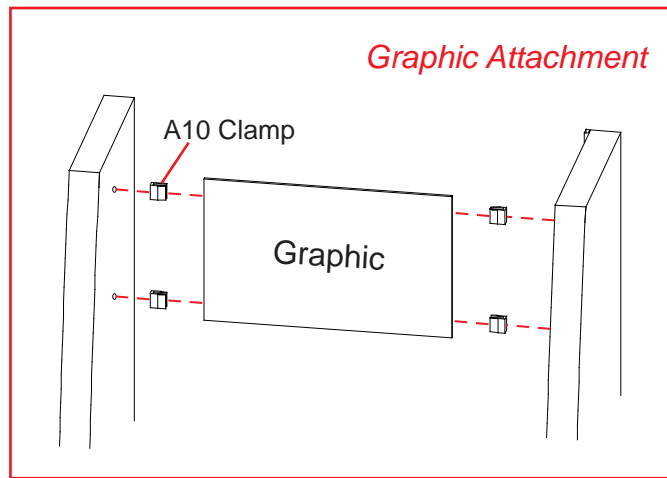

WHEN DISASSEMBLING ALUMINUM EXTRUSION, TIGHTEN ALL SETSCREWS AND LOCKS TO PREVENT LOSS DURING SHIPPING

Part Number	Qty	Description
5	2	24.1965"w Horizontal Extrusion
6	2	24.1965"w Horizontal Extrusion

Steps:

- 1) Attach horizontal extrusions [5] between connectors on side walls as shown.
Note: Slide Groove Cover into groove of connector between horizontals [5].
- 2) Attach horizontal extrusions with Velcro attached [6] between connectors on side walls as shown.
Note: Slide Groove Cover into groove of connector between horizontals [6].
- 3) Velcro shelf supports to inside of assembled base.
- 4) Apply fabric graphic to upper and lower horizontals [6].
- 5) Attach graphic to counter top where indicated using A10 clamps.
- 6) Place shelf on supports and counter top on assembled pedestal.

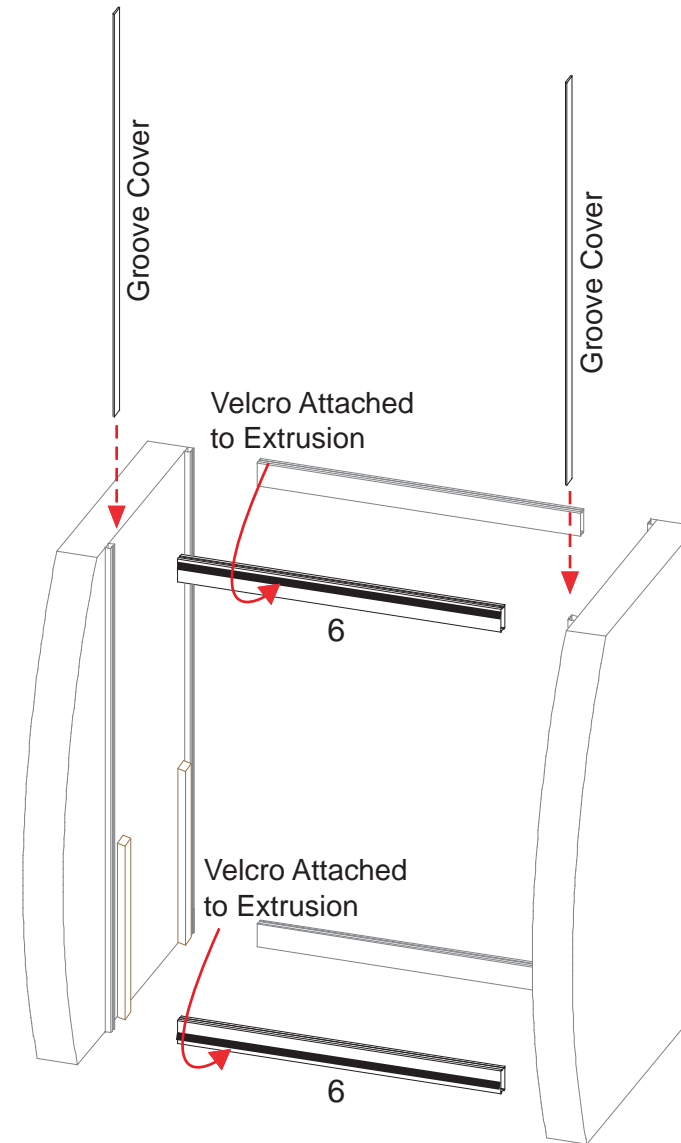
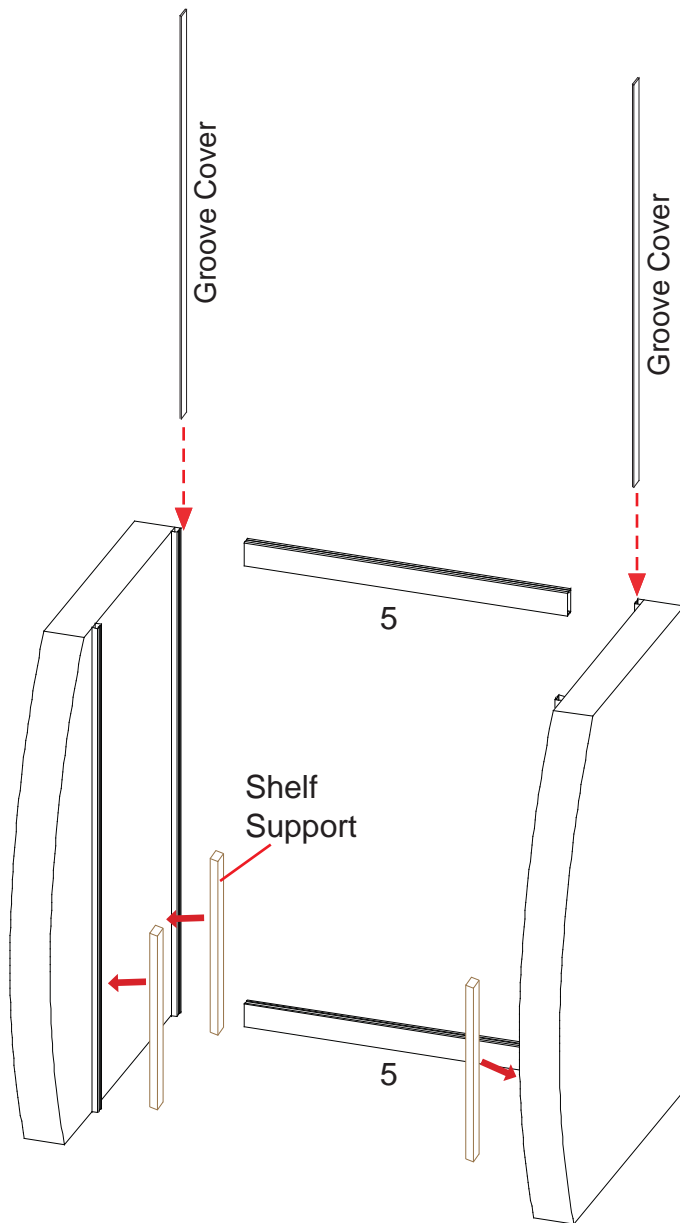

Graphic Attachment
Apply graphic Velcro on the Upper and Lower Horizontal Extrusions [6].

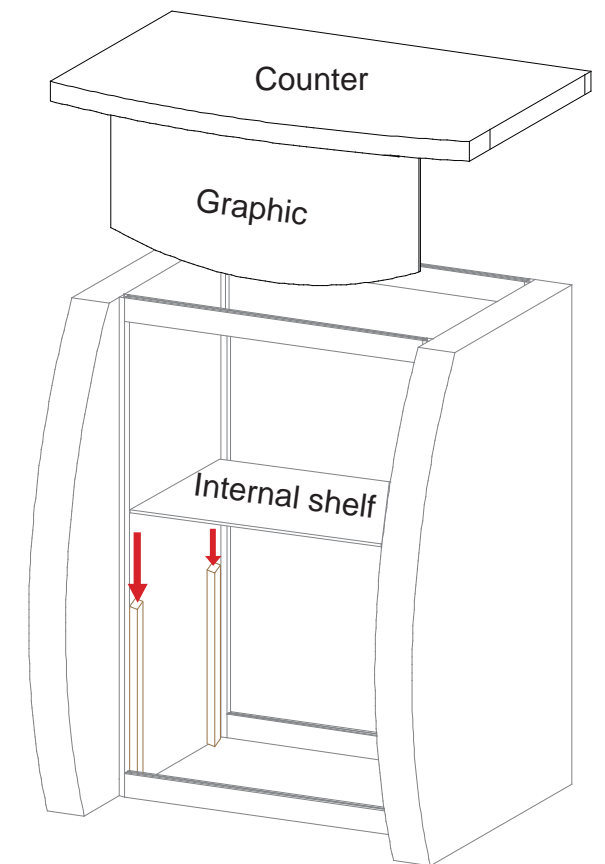
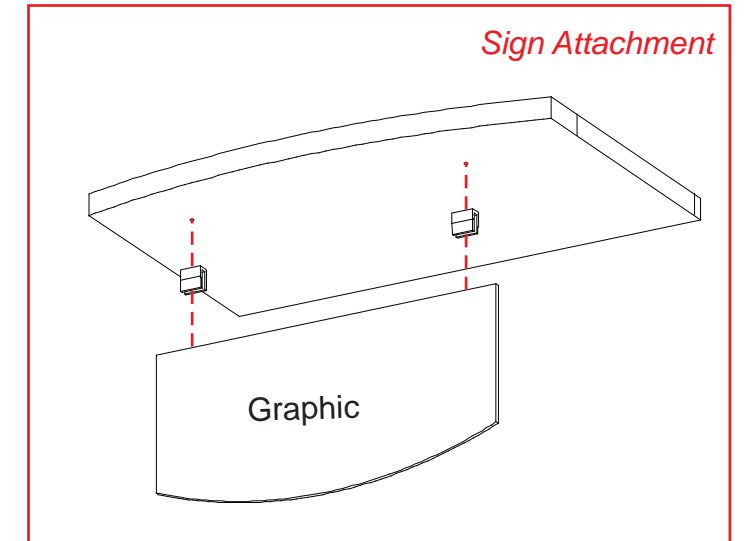

WHEN DISASSEMBLING ALUMINUM EXTRUSION, TIGHTEN ALL SETSCREWS AND LOCKS TO PREVENT LOSS DURING SHIPPING

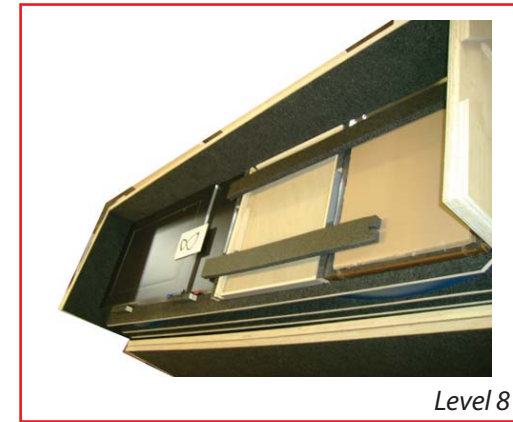
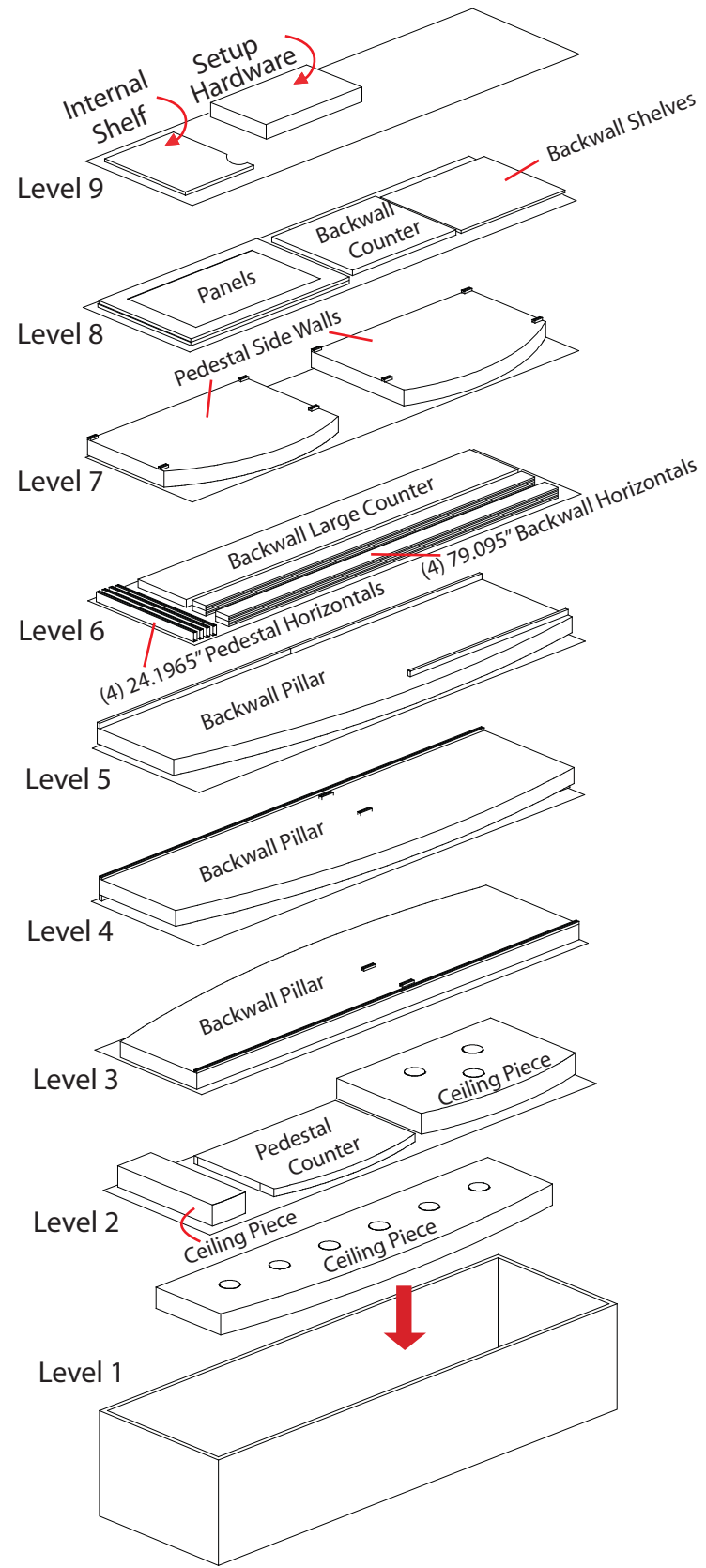

WHEN DISASSEMBLING ALUMINUM EXTRUSION, TIGHTEN ALL SETSCREWS AND LOCKS TO PREVENT LOSS DURING SHIPPING