

10'

Plan View

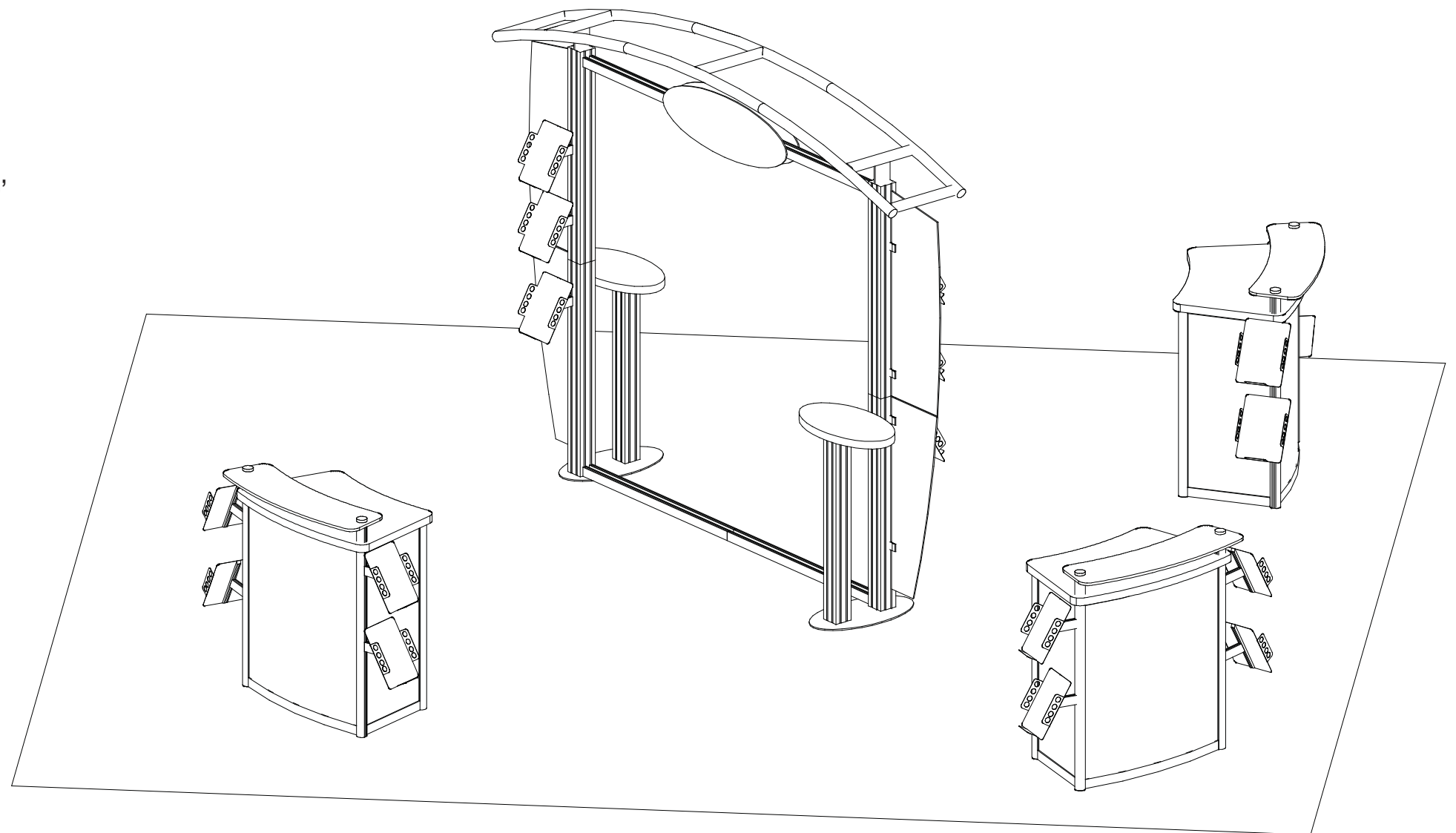

WHEN DISASSEMBLING ALUMINUM EXTRUSION, TIGHTEN ALL SETSCREWS AND LOCKS TO PREVENT LOSS DURING SHIPPING

visionary™ DESIGNS

Using Your Setup Instructions

The Visionary Designs Setup Instructions are created specifically for your configuration. They are laid out sequentially, including an exploded view of the entire display, and then a logical series of detailed steps to assemble the main structure and components. We encourage you to study the instructions **before** attempting to assemble your exhibit.

Each page reminds you to tighten the setscrews after disassembling your exhibit to prevent loss of the locks and setscrews (see below in RED). This is **VERY IMPORTANT**.

Cleaning and Packing Your Display

- 1) Use care when cleaning aluminum extrusion or acrylic inserts. Use only non-abrasive cleaners.
- 2) When cleaning laminate inserts or countertops, use mild cleansers and a soft material such as cotton.
- 3) Keep all display components away from extreme heat and long exposure to sunlight to avoid warping and fading.
- 4) Retain all packing material. It will make re-packing much easier and will reduce the likelihood of shipping damage.



The Tool

Most Visionary Designs exhibits can be assembled with the supplied Hex Key Tool. Occasionally, a flat head screwdriver may be required.



Detail A

Typical Connection



Typical Connection (cont'd)

Most horizontal extrusion connections have a patented expandable lock. This lock inserts into the groove of an opposing extrusion. Tightening the lock with the Hex Key Tool expands the lock and creates a strong positive connection.

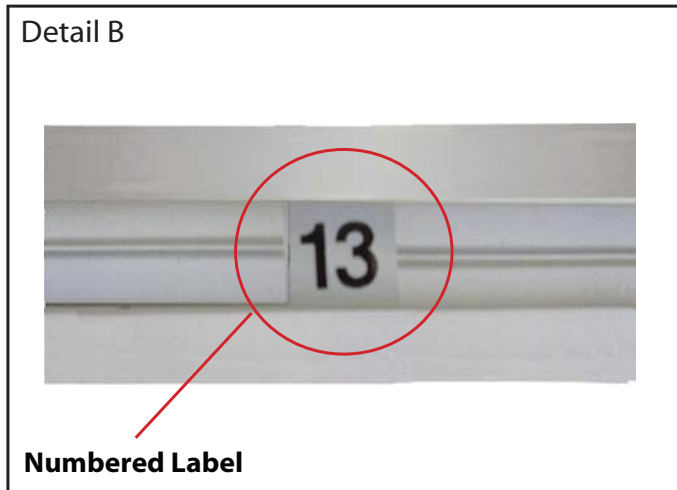

Detail B

Numbered Label

Each extrusion contains a numbered label which corresponds with setup instructions. The label is located within a groove of the extrusion (when possible). With Visionary Designs the labels contain Black numbers unless otherwise specified.



Detail C

Horizontal Inline Connection (remove only one setscrew)

Remove only (1) setscrew when disassembling. Replace setscrew in extrusion after assembling it. Before packing, replace setscrew in extrusion to avoid losing it.

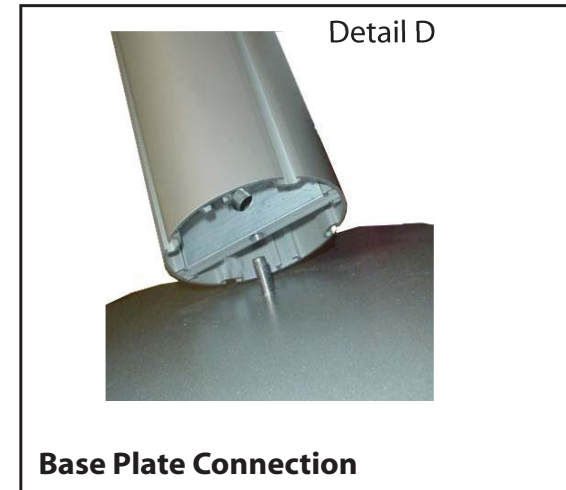

Detail D

Base Plate Connection

Attach base plate to round or square vertical extrusion using the bolt provided. Be careful not to strip the threads.

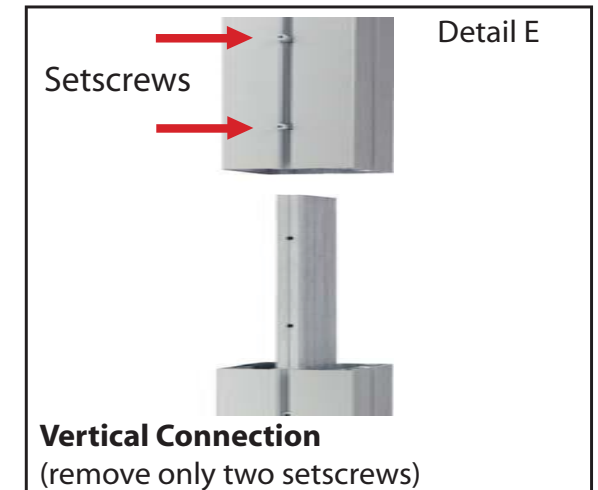

Detail E

Vertical Connection
(remove only two setscrews)

When vertical extrusions are packed in portable cases rather than crates or tubs, they must be broken down into smaller sections which then require assembly.

Remove only (2) setscrews when disassembling. Replace setscrews in extrusion after assembling it. Before packing, replace setscrews in extrusion to avoid losing them.

WHEN DISASSEMBLING ALUMINUM EXTRUSION, TIGHTEN ALL SETSCREWS AND LOCKS TO PREVENT LOSS DURING SHIPPING

Part Number	Qty for Step	Description
1	2	Base Plates
2	2	42" h Lower Vertical extrusion
3	2	42" h Upper Vertical extrusion
4a/4b	2/2	42" Lower Formed Horizontal w/ Velcro attached to Top of member
5a/5b	2/2	42" Middle Formed Horizontal w/ Velcro attached to Bottom of member
6	2	38" h Vertical extrusion

Steps

- 1) Attach vertical extrusions [2 and 6] to the oval base plates [1], see detail D on general information page.
- 2) Place upper vertical extrusions [3] atop of lower vertical extrusions [2].
- 3) Assemble all horizontal extrusions together [4a to 4b and 5a to 5b].
- 4) Attach lower horizontal assemblies [4a/4b] between vertical assemblies [2 and 3] as shown.
NOTE: Velcro on Lower Horizontals must face UP.
- 5) Attach upper horizontal assemblies [5a/5b] between vertical assemblies [2 and 3] as shown.
NOTE: Velcro on Upper Horizontals must face DOWN.
- 7) Place counters tops atop verticals [6] and secure with thumbscrews.
- 8) Apply graphic to assembled backwall, see Attaching Graphics detail.

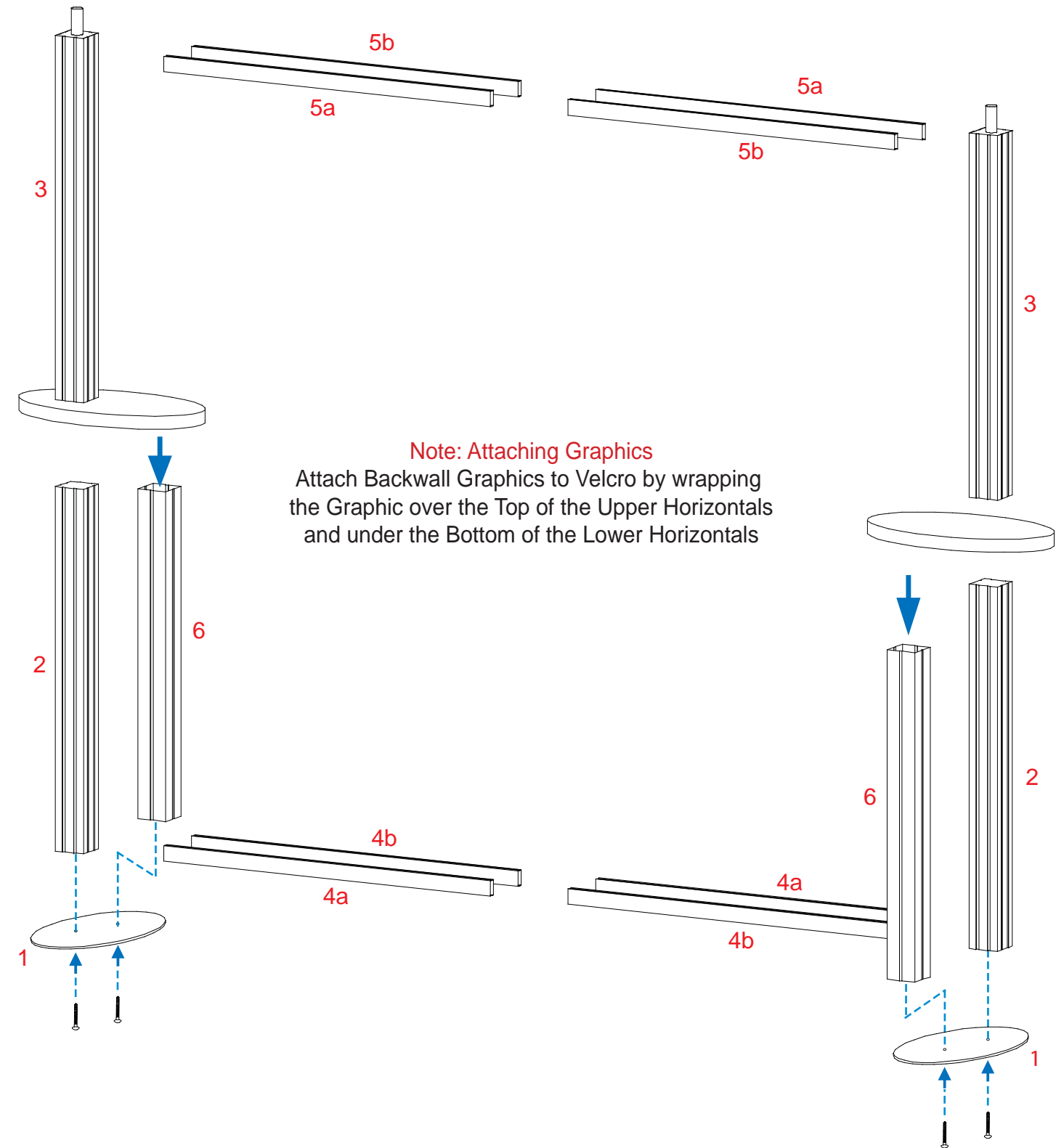
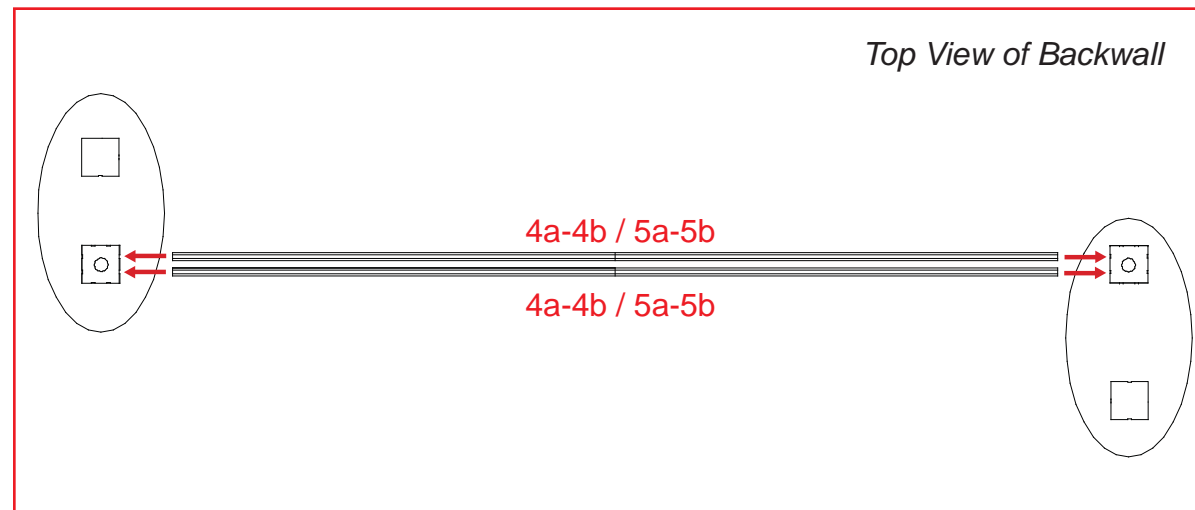

WHEN DISASSEMBLING ALUMINUM EXTRUSION, TIGHTEN ALL SETSCREWS AND LOCKS TO PREVENT LOSS DURING SHIPPING

Literature Rack Attachment

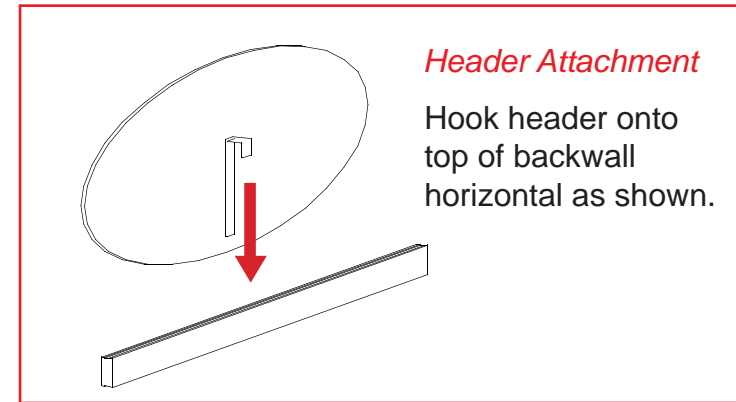
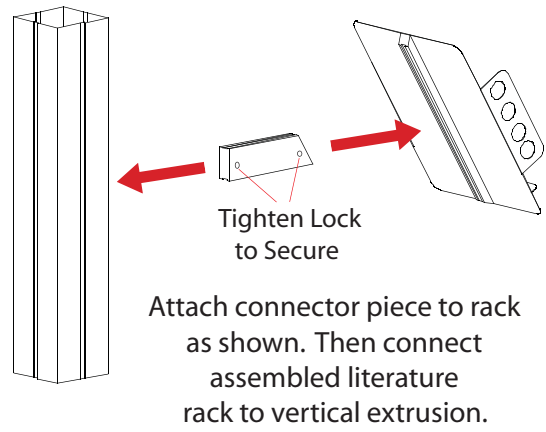

Wing Attachment

Slide A10 Clamp into groove of square extrusion.

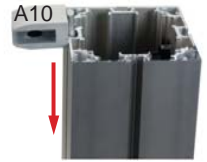

When desired location is found, tighten set screw to secure.

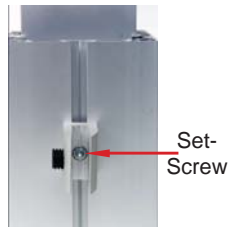

Tighten black plastic set screw to secure Wing in place.

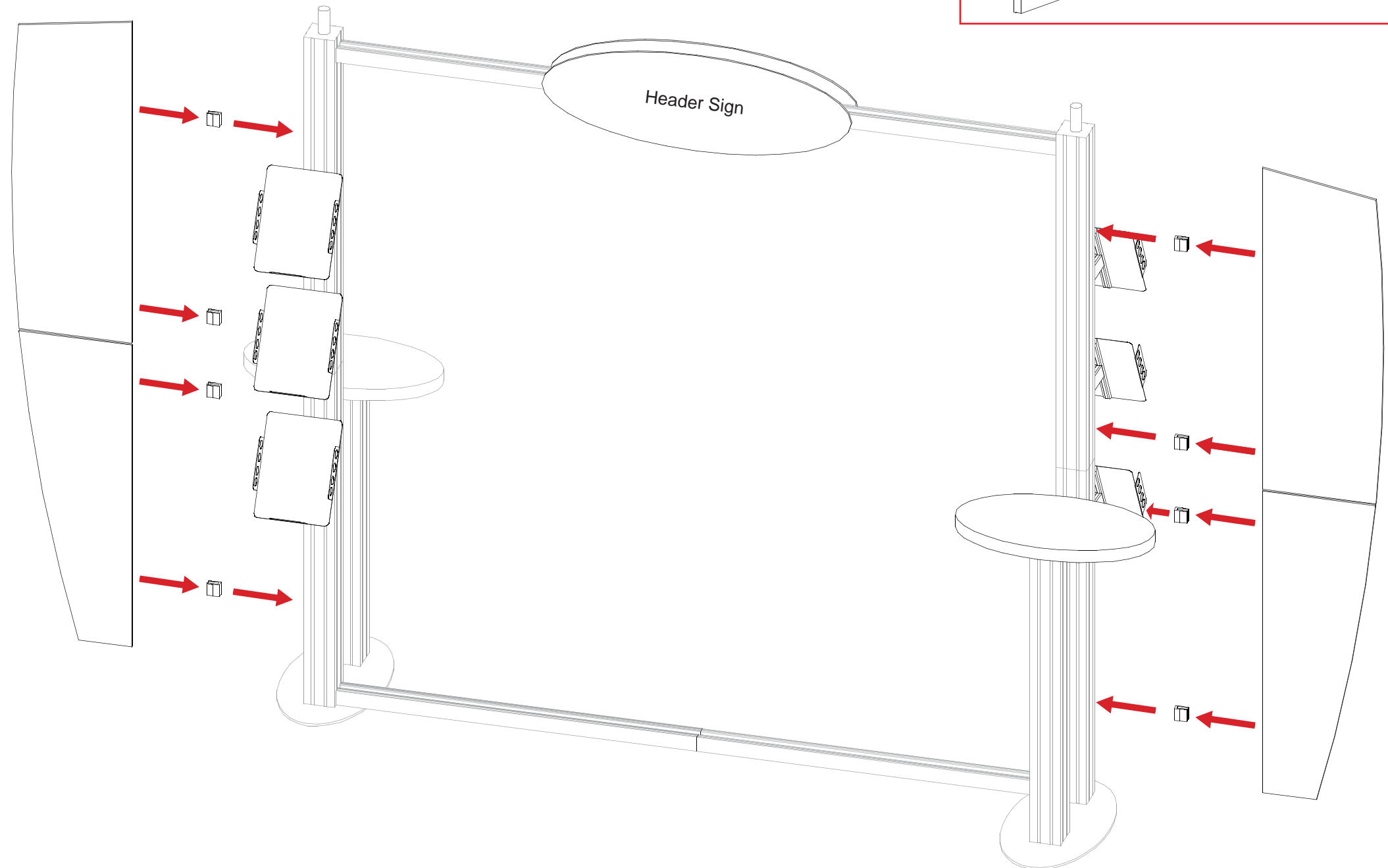
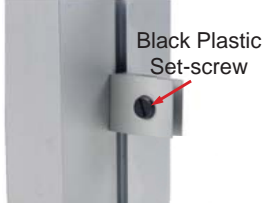

WHEN DISASSEMBLING ALUMINUM EXTRUSION, TIGHTEN ALL SETSCREWS AND LOCKS TO PREVENT LOSS DURING SHIPPING



Steps:

- 1) Connect canopy pieces together as shown.
- 2) Apply pillow case graphic to assembled canopy

Using Your Setup Instructions

The Aero Overhead Sign Setup Instructions are created specifically for your configuration. They include an exploded view of the frame which is sequentially numbered. We encourage you to study the instructions before attempting to assemble your exhibit.

Connections are kept very simple: no tools. Everything assembles with push-button connectors and pre-connected horizontal sections.

Cleaning and Packing Your Display

- 1) Use care when cleaning aluminum extrusion or acrylic inserts. Use only non-abrasive cleaners.
- 2) Retain all packing material. It will make re-packing much easier and will reduce the likelihood of shipping damage.

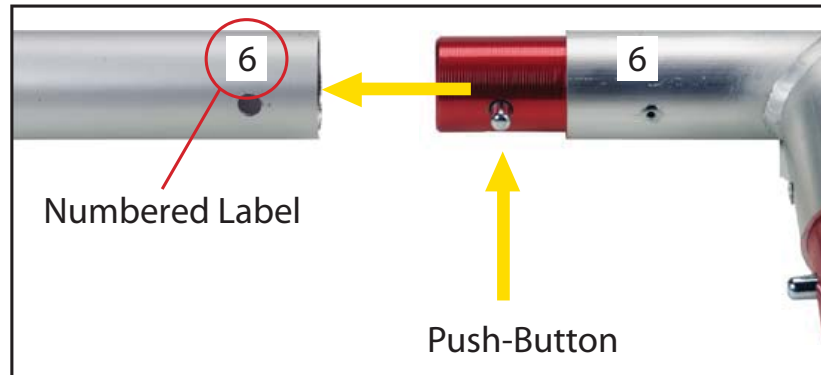
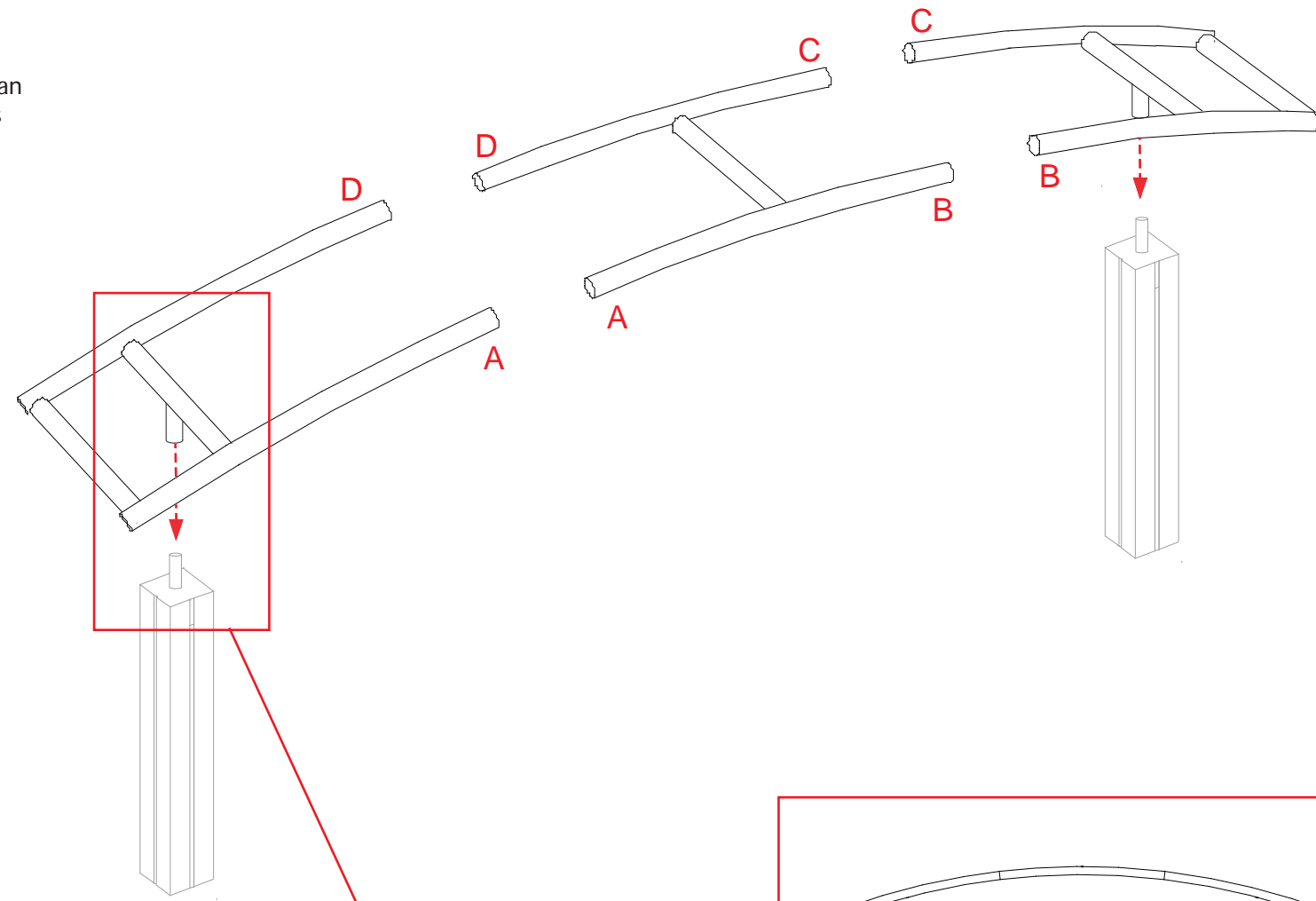

Connections are made by holding the button down and sliding the red tube into opposing tube until the connection is made. To disassemble push button and pull or twist extrusions apart.

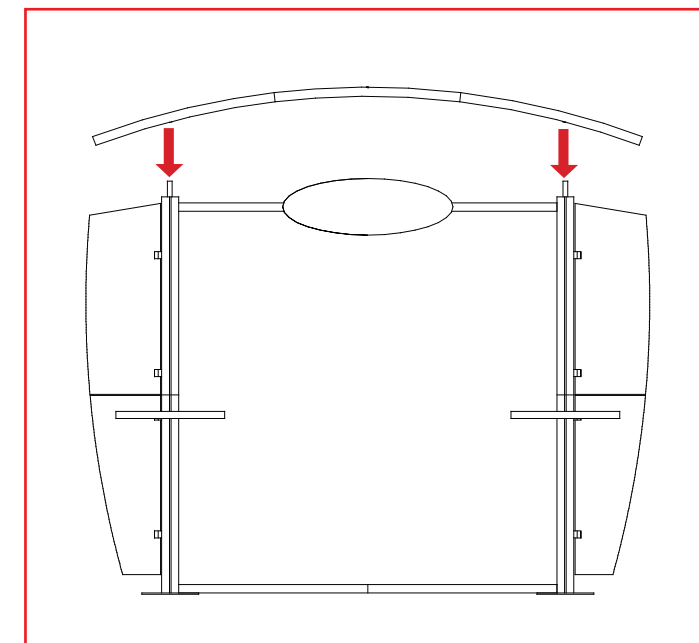
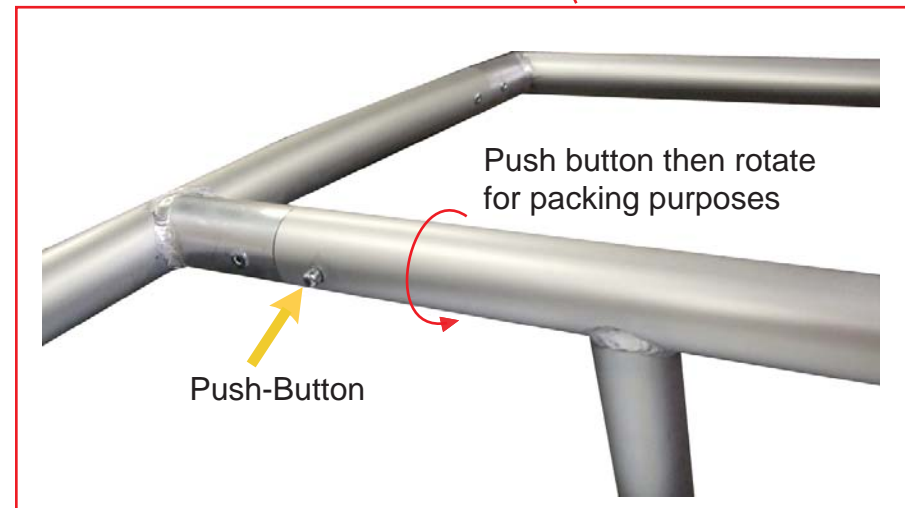

WHEN DISASSEMBLING ALUMINUM EXTRUSION, TIGHTEN ALL SETSCREWS AND LOCKS TO PREVENT LOSS DURING SHIPPING

866.652.2100

Item	Quantity	Description
8	1	42" h Round Vertical Extrusion
9	1	38" h Round Vertical Extrusion w/ Door Stopper
10	1	38" h Round Vertical Extrusion w/ Hinges
11	1	42" h Round Vertical Extrusion
12	2	31.85" Curved Horizontal Extrusion
13	2	23.8" Curved Horizontal Extrusion
14	4	16" Horizontal Extrusion

Steps:

- 1) Attach lower horizontal extrusions [12, 13 and 14] between vertical extrusions [8, 9, 10 and 11] as shown.
- 2) Place inserts and door where indicated.
- 3) Attach upper horizontal extrusions [12, 13 and 14] between vertical extrusions [8, 9, 10 and 11].
- 4) Velcro internal shelf supports to inside assembled pedestal
- 5) Set internal shelf atop shelf supports
- 6) Slide counter top on vertical extrusions [8 and 11] and rest atop pedestal.
- 7) Attach plex shelf using caps.

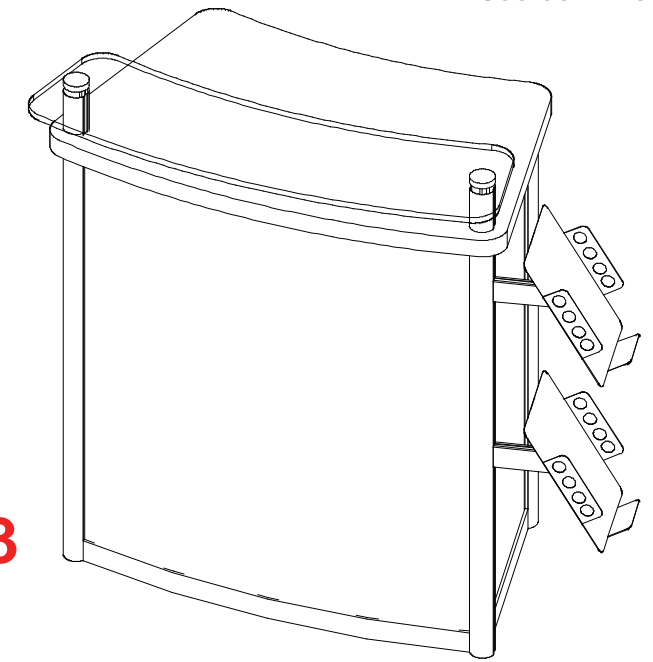

QTY. 3

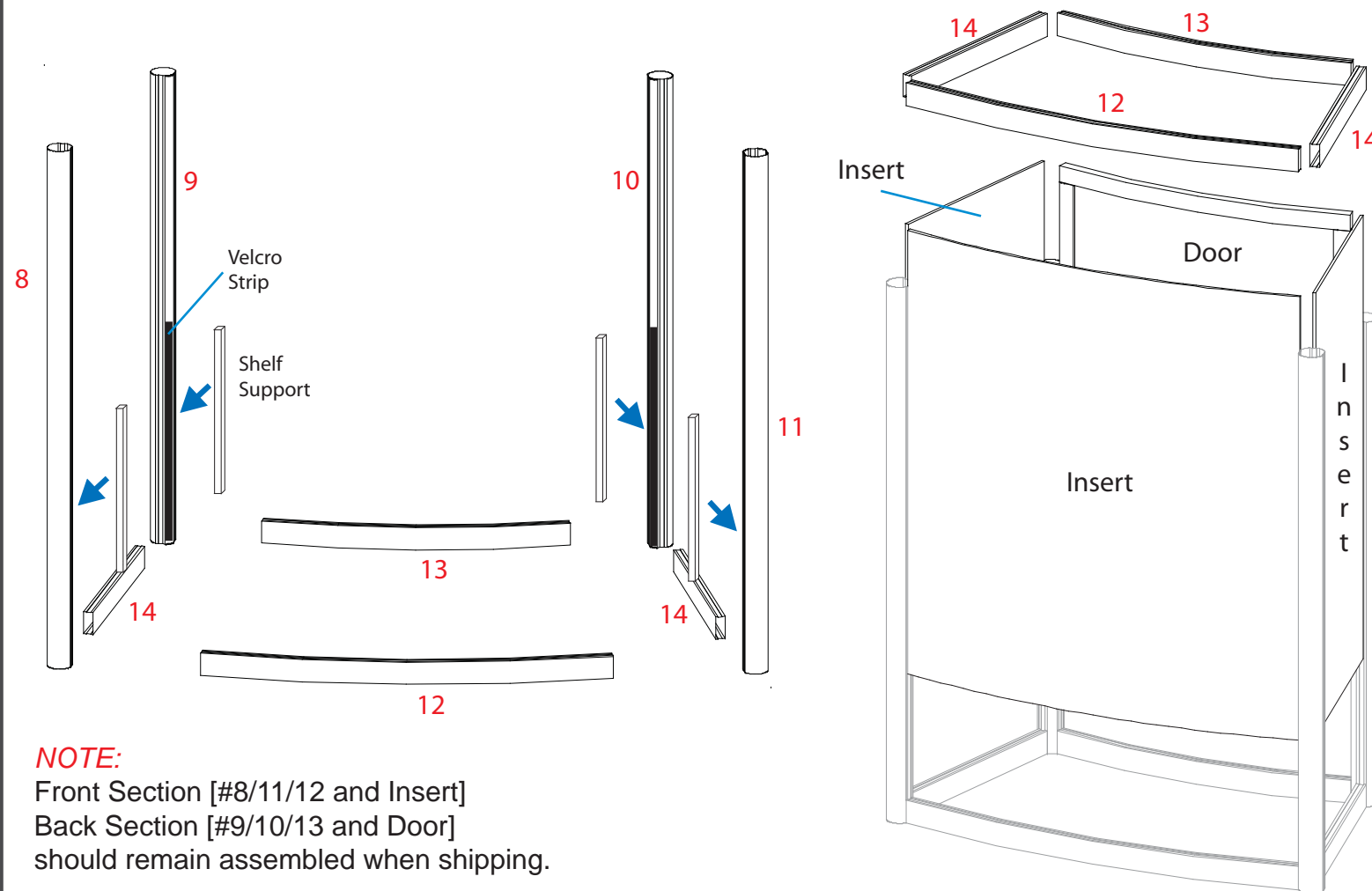

NOTE:
 Front Section [#8/11/12 and Insert]
 Back Section [#9/10/13 and Door]
 should remain assembled when shipping.

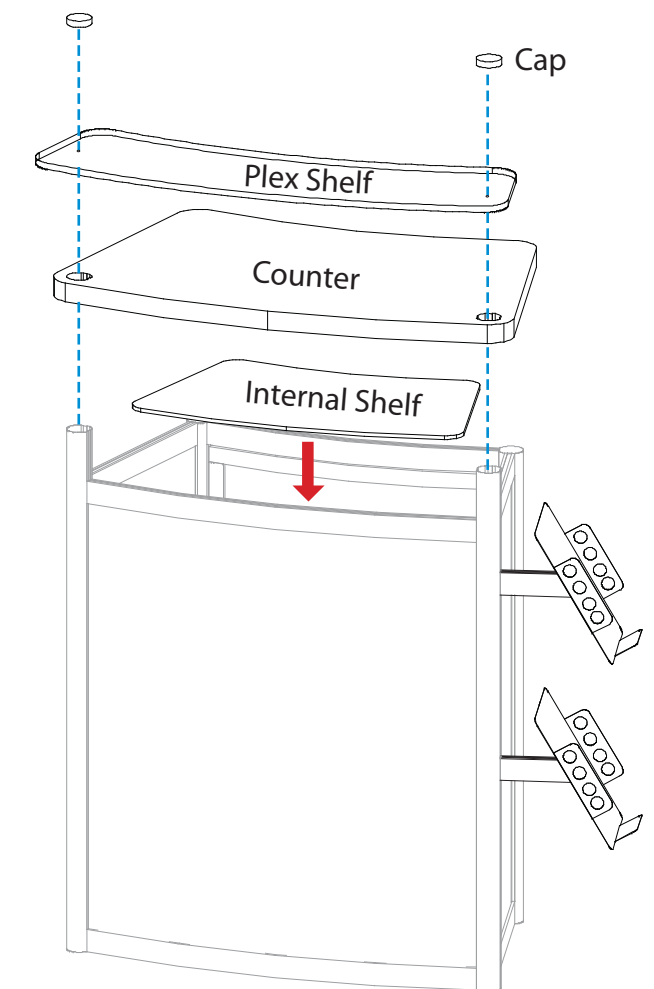
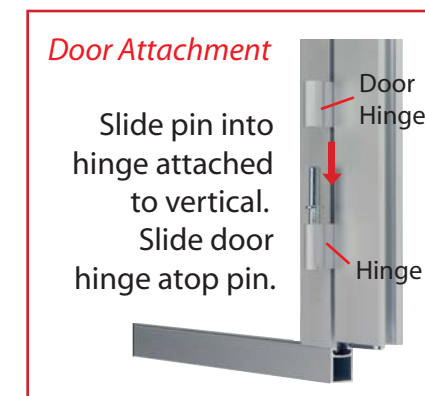
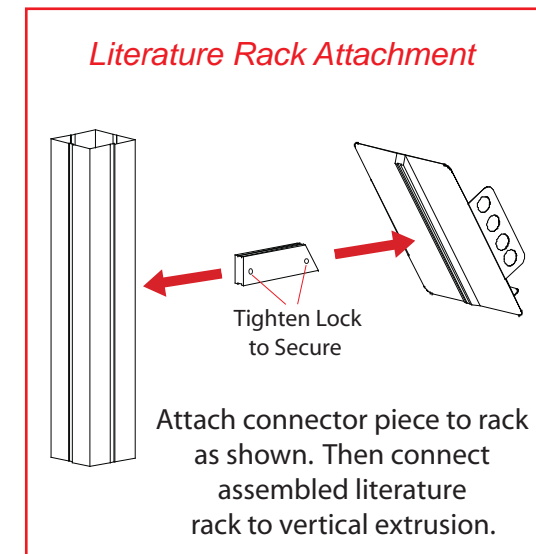

WHEN DISASSEMBLING ALUMINUM EXTRUSION, TIGHTEN ALL SETSCREWS AND LOCKS TO PREVENT LOSS DURING SHIPPING