

Plan View

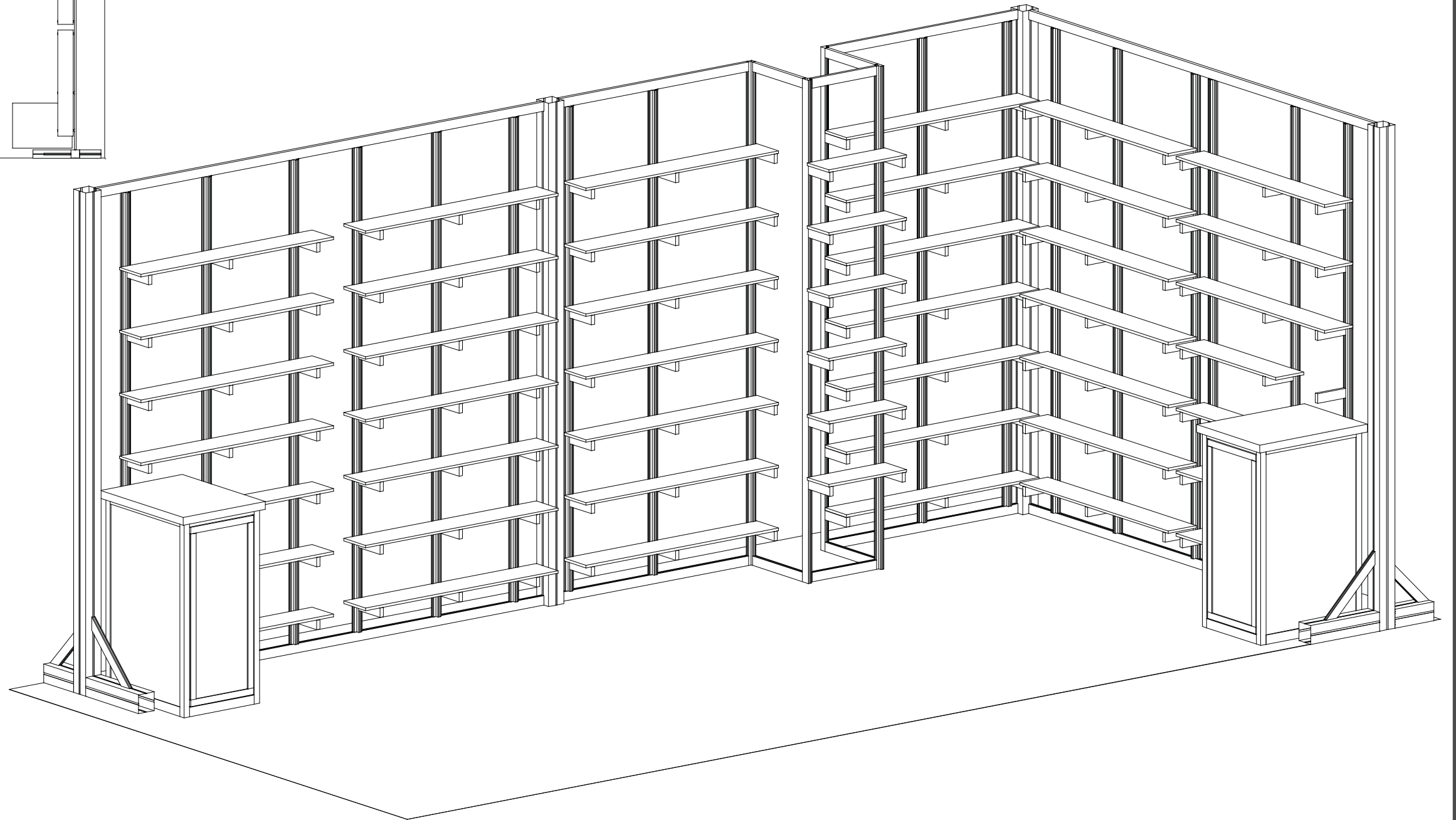

WHEN DISASSEMBLING ALUMINUM EXTRUSION, TIGHTEN ALL SETSCREWS AND LOCKS TO PREVENT LOSS DURING SHIPPING

# visionary™ IDESIGNS

## Using Your Setup Instructions

The Visionary Designs Setup Instructions are created specifically for your configuration. They are laid out sequentially, including an exploded view of the entire display, and then a logical series of detailed steps to assemble the main structure and components. We encourage you to study the instructions **before** attempting to assemble your exhibit.

Each page reminds you to tighten the setscrews after disassembling your exhibit to prevent loss of the locks and setscrews (see below in RED). This is **VERY IMPORTANT**.

## Cleaning and Packing Your Display

- 1) Use care when cleaning aluminum extrusion or acrylic inserts. Use only non-abrasive cleaners.
- 2) When cleaning laminate inserts or countertops, use mild cleansers and a soft material such as cotton.
- 3) Keep all display components away from extreme heat and long exposure to sunlight to avoid warping and fading.
- 4) Retain all packing material. It will make re-packing much easier and will reduce the likelihood of shipping damage.



**The Tool**

Most Visionary Designs exhibits can be assembled with the supplied Hex Key Tool. Occasionally, a flat head screwdriver may be required.



**Typical Connection**

Most horizontal extrusion connections have a patented expandable lock. This lock inserts into the groove of an opposing extrusion. Tightening the lock with the Hex Key Tool expands the lock and creates a strong positive connection.



**Typical Connection (cont'd)**



**Numbered Label**

Each extrusion contains a numbered label which corresponds with setup instructions. The label is located within a groove of the extrusion (when possible). With Visionary Designs the labels contain Black numbers unless otherwise specified.



**Horizontal Inline Connection** (remove only one setscrew)

Remove only (1) setscrew when disassembling. Replace setscrew in extrusion after assembling it. Before packing, replace setscrew in extrusion to avoid losing it.

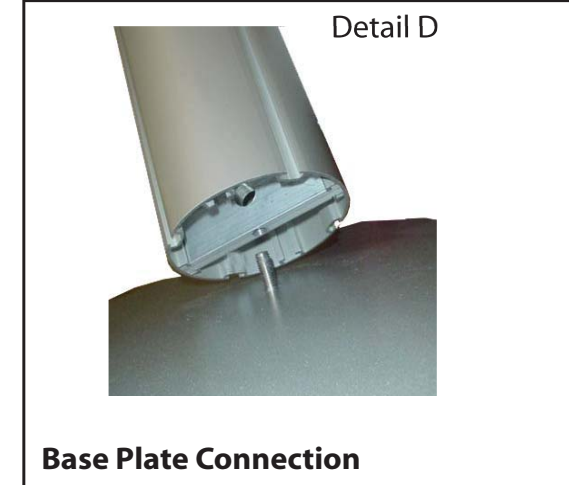

**Base Plate Connection**

Attach base plate to round or square vertical extrusion using the bolt provided. Be careful not to strip the threads.

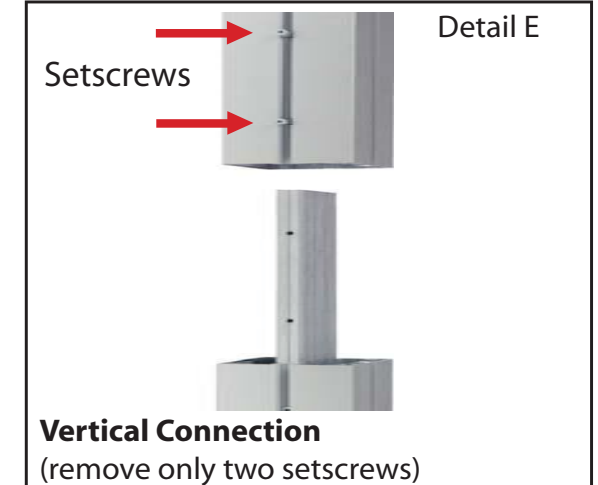

**Vertical Connection**  
(remove only two setscrews)

When vertical extrusions are packed in portable cases rather than crates or tubs, they must be broken down into smaller sections which then require assembly.

Remove only (2) setscrews when disassembling. Replace setscrews in extrusion after assembling it. Before packing, replace setscrews in extrusion to avoid losing them.

**WHEN DISASSEMBLING ALUMINUM EXTRUSION, TIGHTEN ALL SETSCREWS AND LOCKS TO PREVENT LOSS DURING SHIPPING**

866.652.2100

Part Number	Qty for Step	Description
1	4	96" h Square Vertical
2	4	104" w Horizontal Extrusion
3	4	44" w Horizontal Extrusion
4	6	15" w Horizontal Extrusion
5	15	92.417" Vertical T- Extrusion
6	2	96" h Vertical T- Extrusion
7	2	96" h Vertical 90° Extrusion
17	2	16" Square Horizontal
18	2	16" Tapered Extrusion
19	2	9" Square Horizontal
20	2	9" Tapered Extrusion

**Steps**

- 1) Attach horizontal extrusions [2, 3, and 4] between vertical extrusions [1, 6, and 7] as shown.
  - 2) Connect vertical T-extrusions between horizontals [2 and 3] as shown.
- Note: These verticals may need to be adjusted from left to right for shelf placement.
- 3) Connect extrusion support pieces [17 thru 20] to far left and far right extrusions [1].

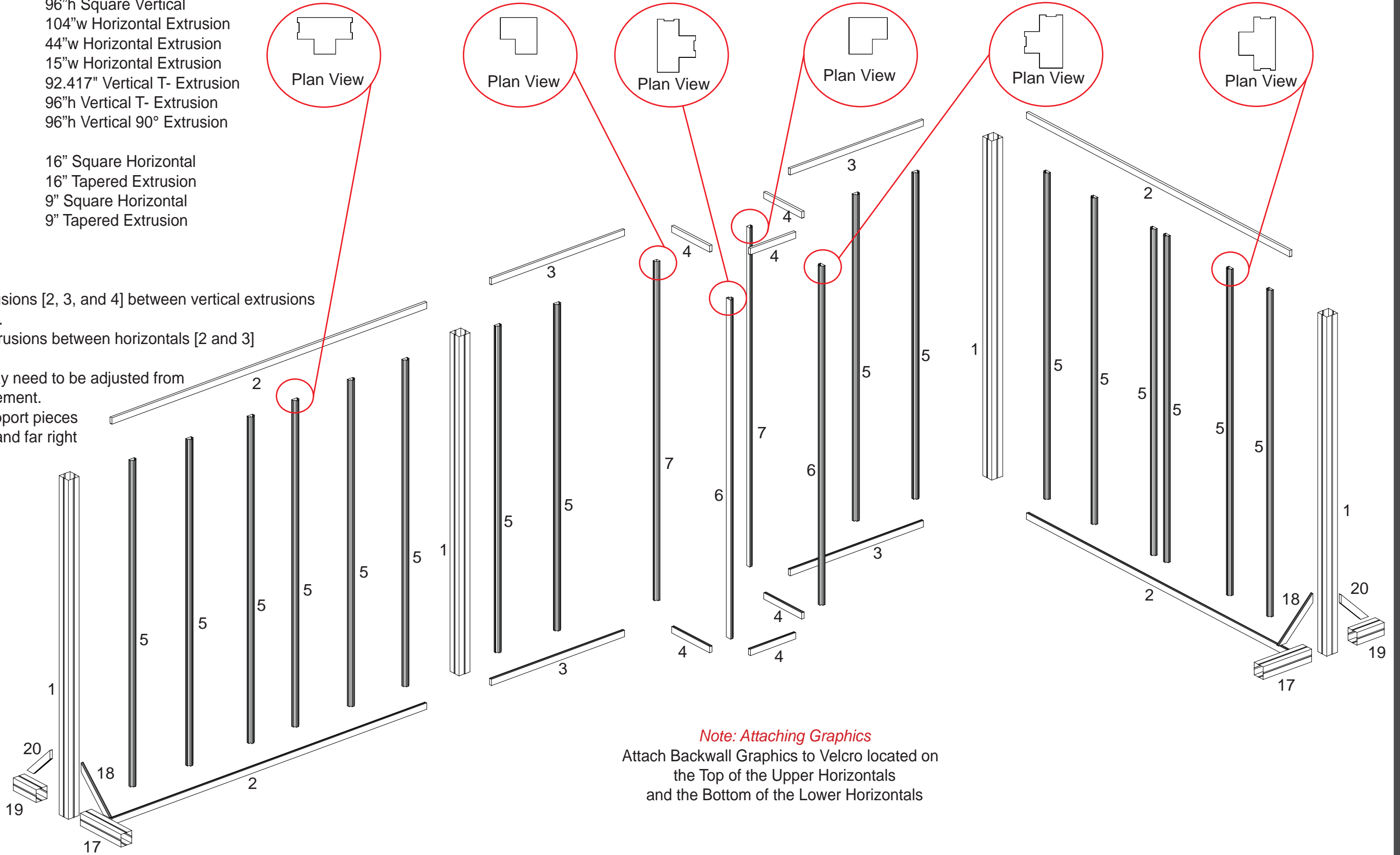

**Note: Attaching Graphics**  
 Attach Backwall Graphics to Velcro located on the Top of the Upper Horizontals and the Bottom of the Lower Horizontals

**WHEN DISASSEMBLING ALUMINUM EXTRUSION, TIGHTEN ALL SETSCREWS AND LOCKS TO PREVENT LOSS DURING SHIPPING**

NOTE: All shelving is 44.75" w unless otherwise indicated.

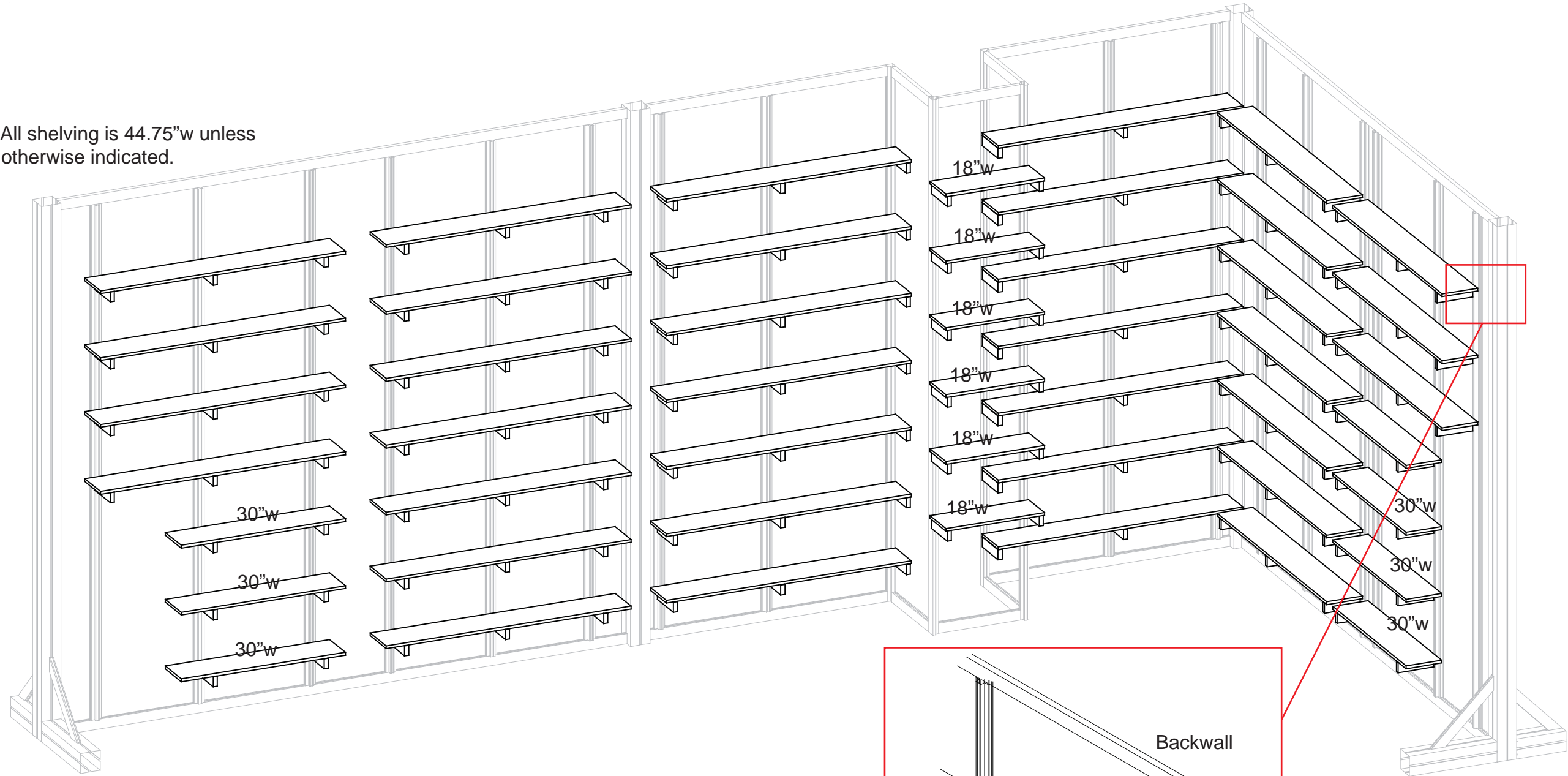

Attach extrusion pieces [8 and 8A] to Vertical T-extrusions [x] and space by using wood block provided and placing in between shelf supports and adjusting to desired height.

Continue this for all shelving.

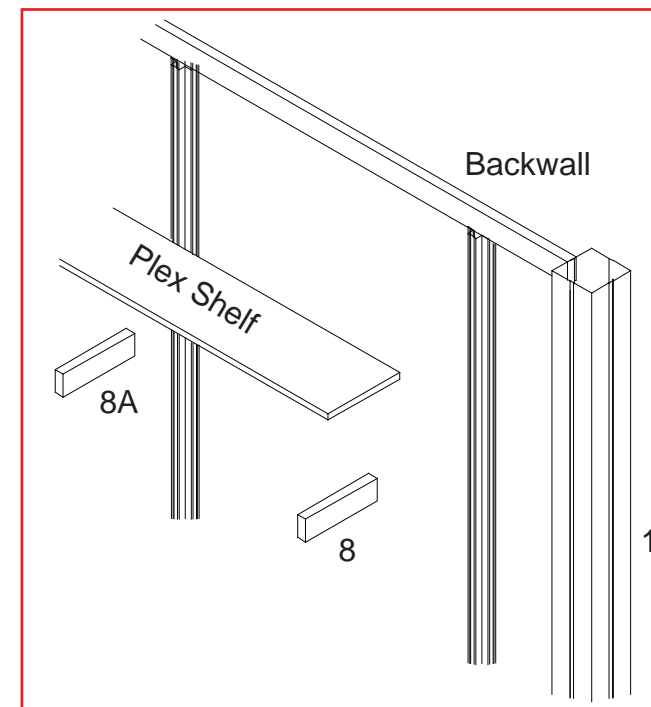

**WHEN DISASSEMBLING ALUMINUM EXTRUSION, TIGHTEN ALL SETSCREWS AND LOCKS TO PREVENT LOSS DURING SHIPPING**

866.652.2100

Part Number	Qty for Step	Description
9	2	15" w Horizontal Extrusion
10	1	38" h 90° Vertical Extrusion
11	2	21" w Horizontal Extrusion
12	1	38" h 90° Vertical Extrusion
13	2	15" w Horizontal Extrusion
14	1	38" h 90° Vertical Extrusion
15	2	21" w Horizontal Extrusion
16	1	38" h 90° Vertical Extrusion

Steps

- 1) Connect lower horizontal extrusions [9, 11, 13 and 15] between vertical extrusions [10, 12, 14, and 16] as shown below.
- 2) Place inserts and door as shown.
- 3) Connect upper horizontal extrusions [9, 11, 13 and 15] between vertical extrusions [10, 12, 14, and 16].
- 4) Place Counter Top.

\*\*Repeat Steps for both Pedestals.

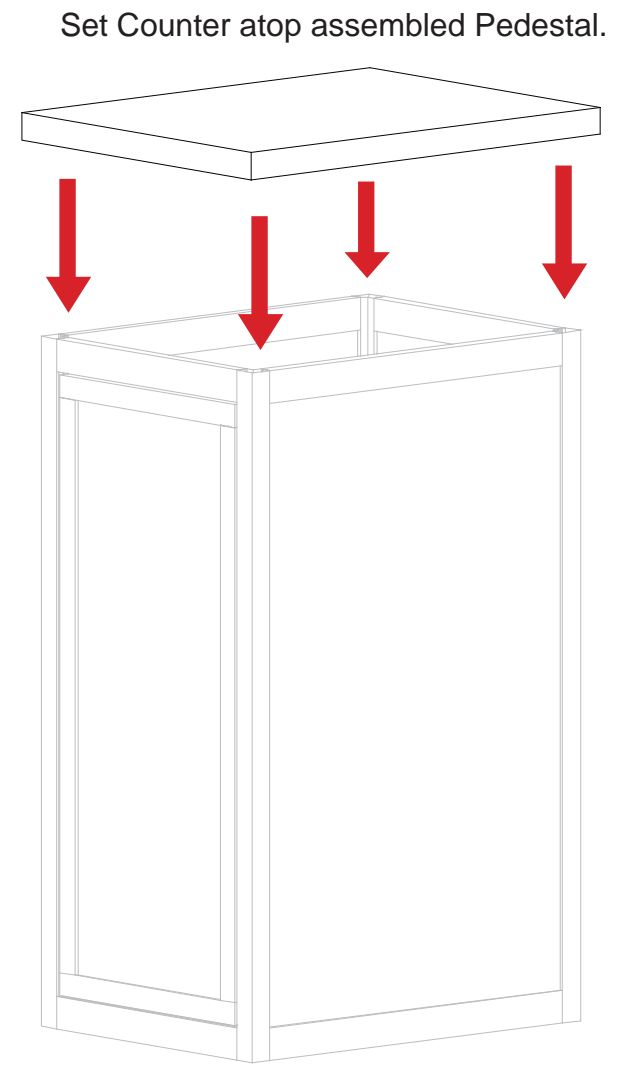
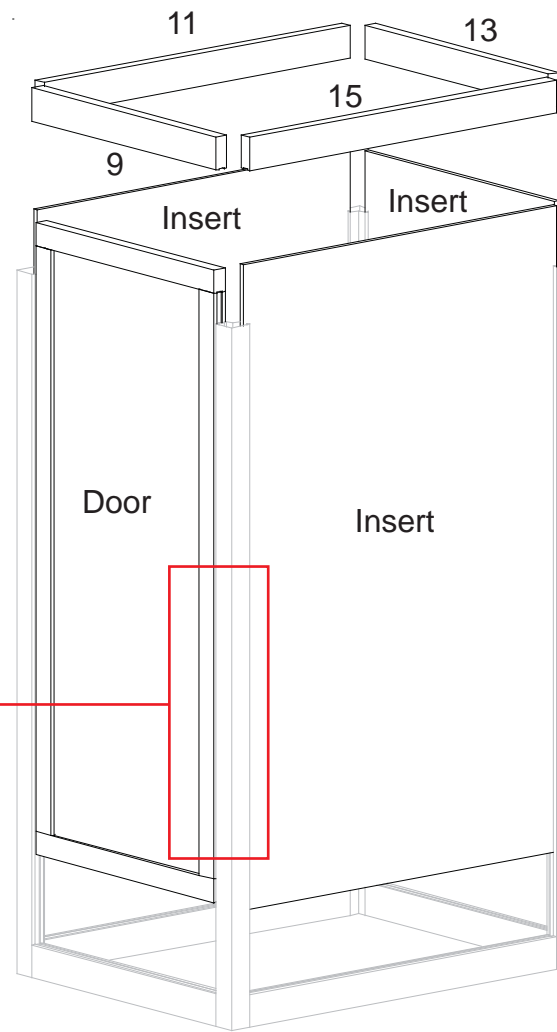
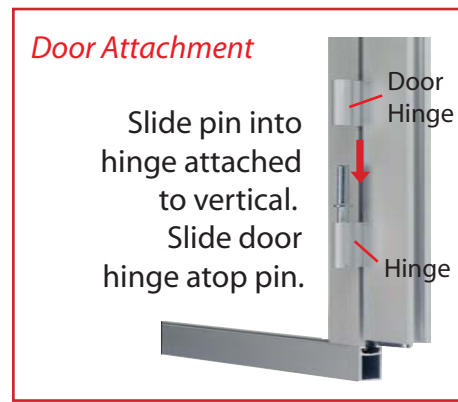
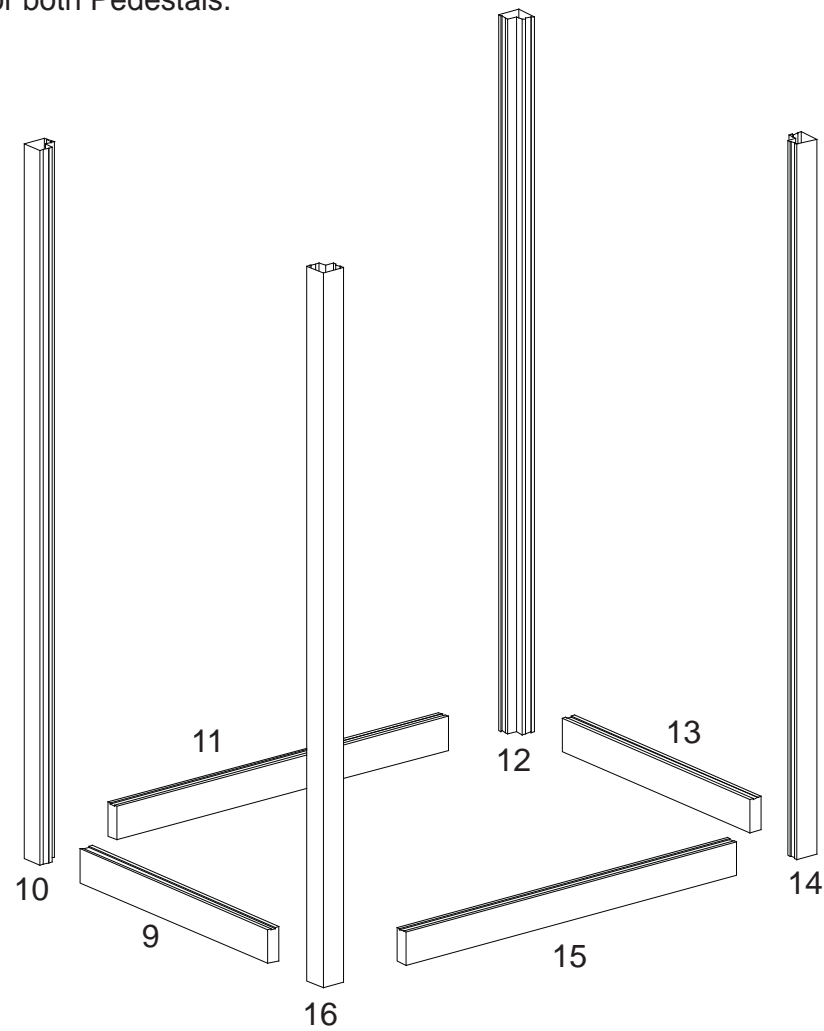

**WHEN DISASSEMBLING ALUMINUM EXTRUSION, TIGHTEN ALL SETSCREWS AND LOCKS TO PREVENT LOSS DURING SHIPPING**

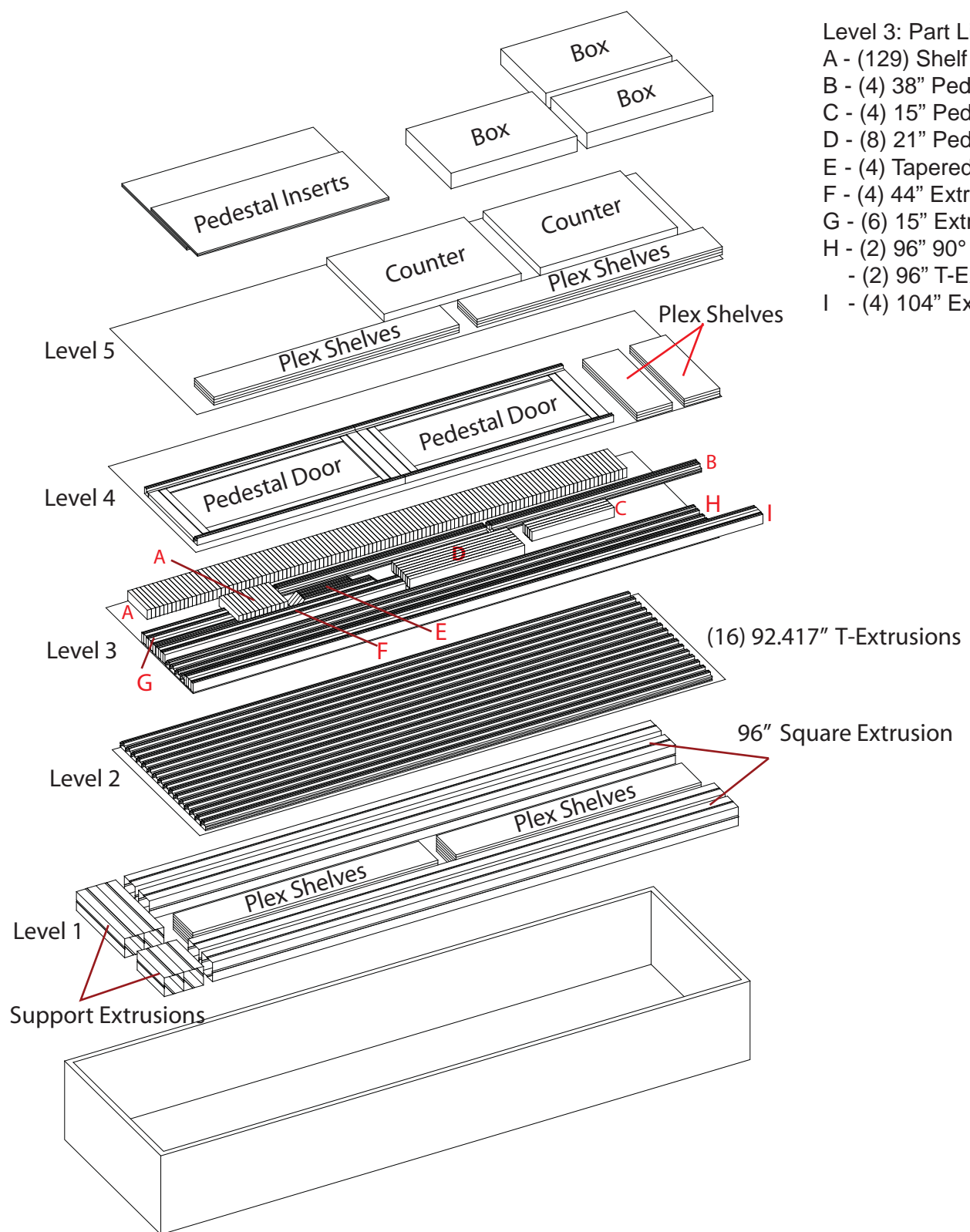

Level 3: Part List

- A - (129) Shelf Support Extrusions
- B - (4) 38" Pedestal Extrusion
- C - (4) 15" Pedestal Horizontal Extrusion
- D - (8) 21" Pedestal Horizontal Extrusion
- E - (4) Tapered Extrusion
- F - (4) 44" Extrusion
- G - (6) 15" Extrusion
- H - (2) 96" 90° Extrusion
- (2) 96" T-Extrusion
- I - (4) 104" Extrusion



Level 4



Level 5

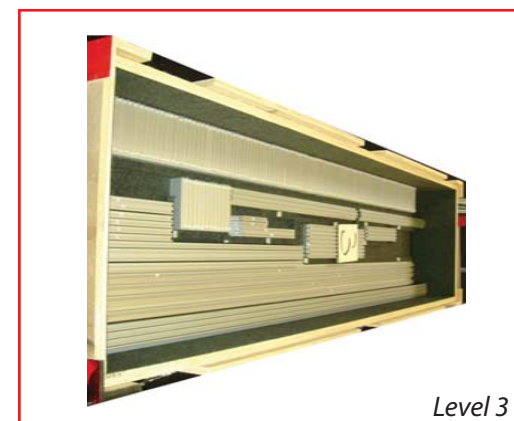

Level 3



Level 2



Level 1



Level 5

**WHEN DISASSEMBLING ALUMINUM EXTRUSION, TIGHTEN ALL SETSCREWS AND LOCKS TO PREVENT LOSS DURING SHIPPING**