

Plan View

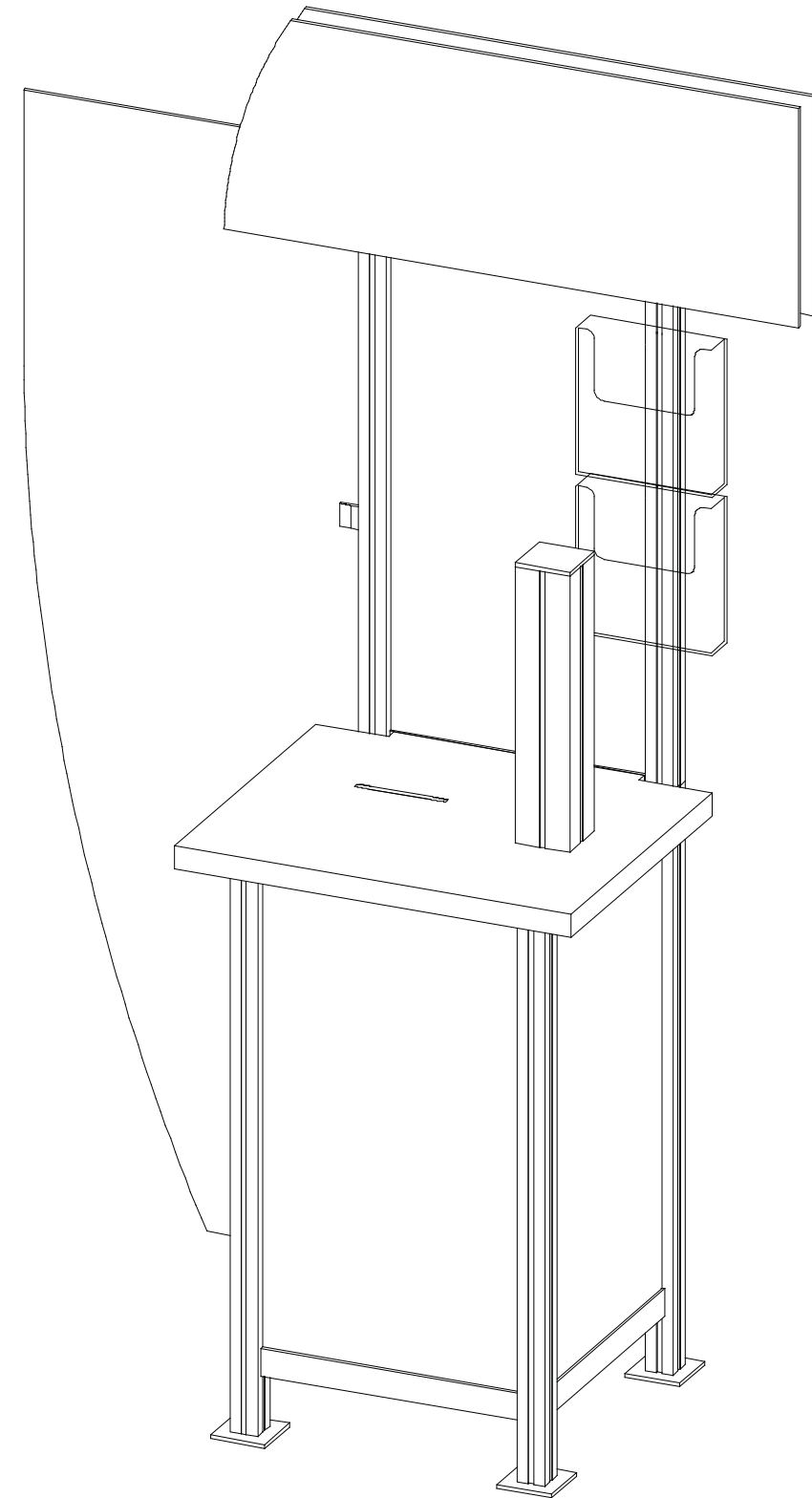

WHEN DISASSEMBLING ALUMINUM EXTRUSION, TIGHTEN ALL SETSCREWS AND LOCKS TO PREVENT LOSS DURING SHIPPING

visionary™ IDESIGNS

Using Your Setup Instructions

The Visionary Designs Setup Instructions are created specifically for your configuration. They are laid out sequentially, including an exploded view of the entire display, and then a logical series of detailed steps to assemble the main structure and components. We encourage you to study the instructions **before** attempting to assemble your exhibit.

Each page reminds you to tighten the setscrews after disassembling your exhibit to prevent loss of the locks and setscrews (see below in RED). This is **VERY IMPORTANT**.

Cleaning and Packing Your Display

- 1) Use care when cleaning aluminum extrusion or acrylic inserts. Use only non-abrasive cleaners.
- 2) When cleaning laminate inserts or countertops, use mild cleansers and a soft material such as cotton.
- 3) Keep all display components away from extreme heat and long exposure to sunlight to avoid warping and fading.
- 4) Retain all packing material. It will make re-packing much easier and will reduce the likelihood of shipping damage.



The Tool

Most Visionary Designs exhibits can be assembled with the supplied Hex Key Tool. Occasionally, a flat head screwdriver may be required.



Typical Connection

Most horizontal extrusion connections have a patented expandable lock. This lock inserts into the groove of an opposing extrusion. Tightening the lock with the Hex Key Tool expands the lock and creates a strong positive connection.



Typical Connection (cont'd)

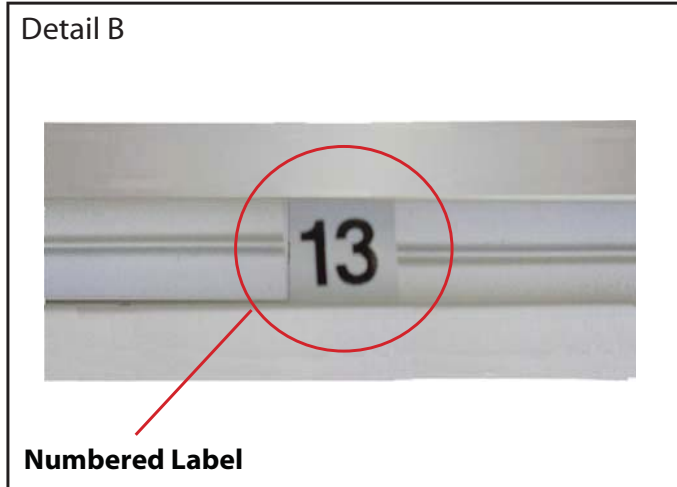

Detail B

Numbered Label

Each extrusion contains a numbered label which corresponds with setup instructions. The label is located within a groove of the extrusion (when possible). With Visionary Designs the labels contain Black numbers unless otherwise specified.



Detail C

Horizontal Inline Connection (remove only one setscrew)

Remove only (1) setscrew when disassembling. Replace setscrew in extrusion after assembling it. Before packing, replace setscrew in extrusion to avoid losing it.

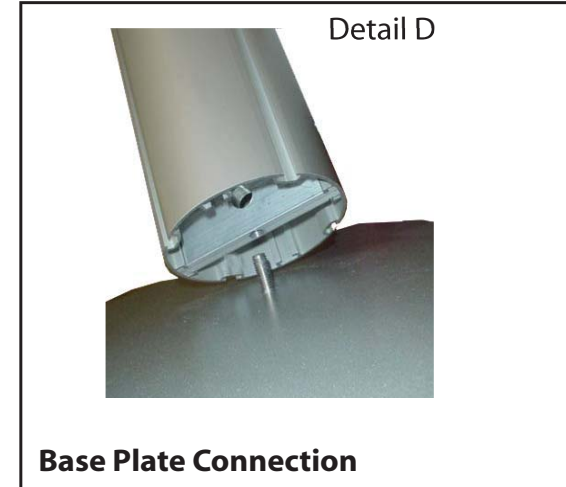

Detail D

Base Plate Connection

Attach base plate to round or square vertical extrusion using the bolt provided. Be careful not to strip the threads.

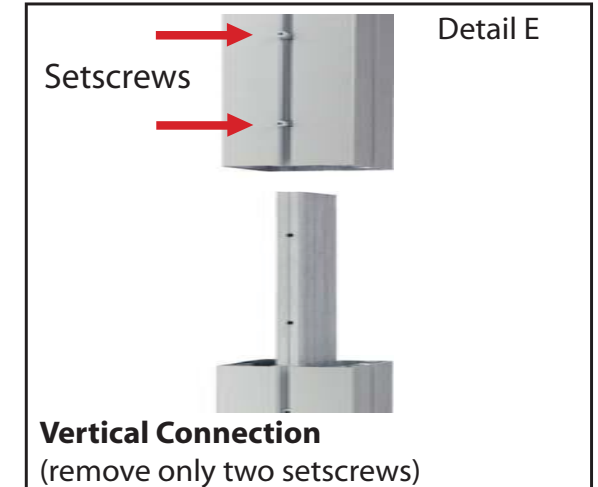

Detail E

Vertical Connection
(remove only two setscrews)

When vertical extrusions are packed in portable cases rather than crates or tubs, they must be broken down into smaller sections which then require assembly.

Remove only (2) setscrews when disassembling. Replace setscrews in extrusion after assembling it. Before packing, replace setscrews in extrusion to avoid losing them.

WHEN DISASSEMBLING ALUMINUM EXTRUSION, TIGHTEN ALL SETSCREWS AND LOCKS TO PREVENT LOSS DURING SHIPPING

Item	Qty.	Description
1	4	Base Plate
2	1	38" h Vertical Extrusion
3	1	38" h Vertical Extrusion
4	1	38" h Vertical Extrusion w/ Hinges
5	1	38" h Vertical Extrusion w/ Door Stop
6	4	17" w Horizontal Extrusion w/ Lip
7	1	38" h Vertical Extrusion
8	1	38" h Vertical Extrusion
9	5	17" w Horizontal Extrusion

Steps:

- 1) Attach vertical extrusions [2, 3, 4 and 5] to base plates [1].
- 2) Connect horizontal extrusions [6] between vertical extrusions at 3-3/4" up from base plate to bottom of metal.
- 3) Set floor atop lips of horizontal extrusions.
- 4) Attach upper verticals to lower verticals [7 to 4 and 8 to 5].
- 5) Place inserts and attach door where indicated.
- 6) Connect horizontal extrusions 9 between vertical extrusions and atop inserts and door.
- 7) Slide perforated metal between extrusions [7 and 8].
- 8) Connect horizontal extrusion [9] between extrusions [7 and 8] and atop insert.

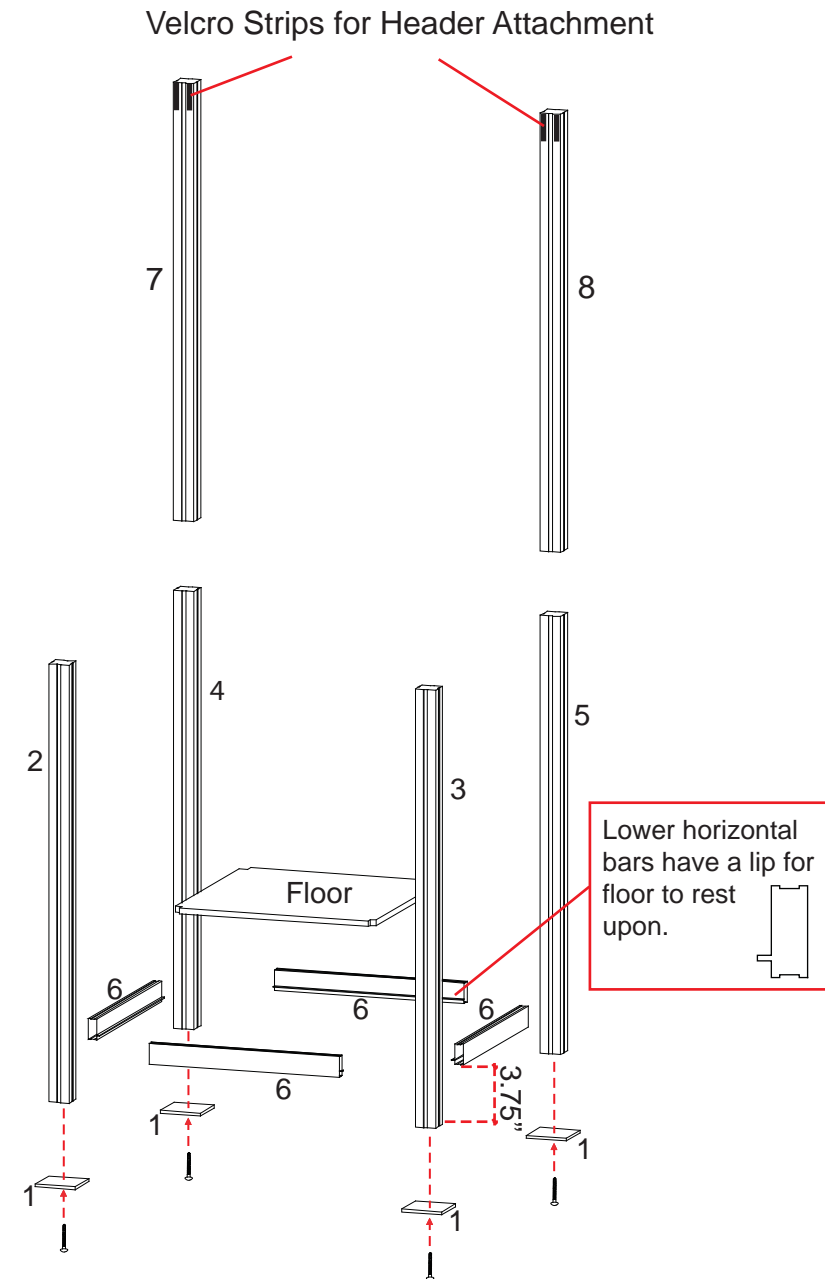
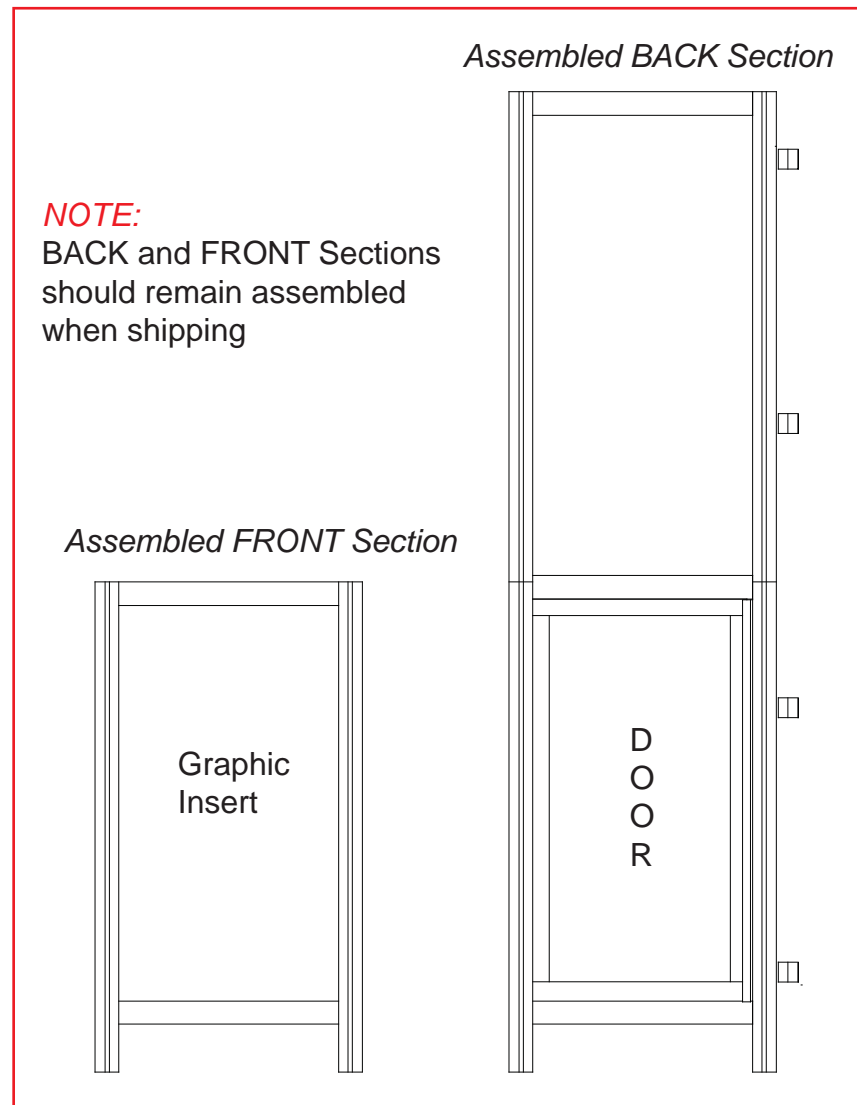

Lower horizontal bars have a lip for floor to rest upon.

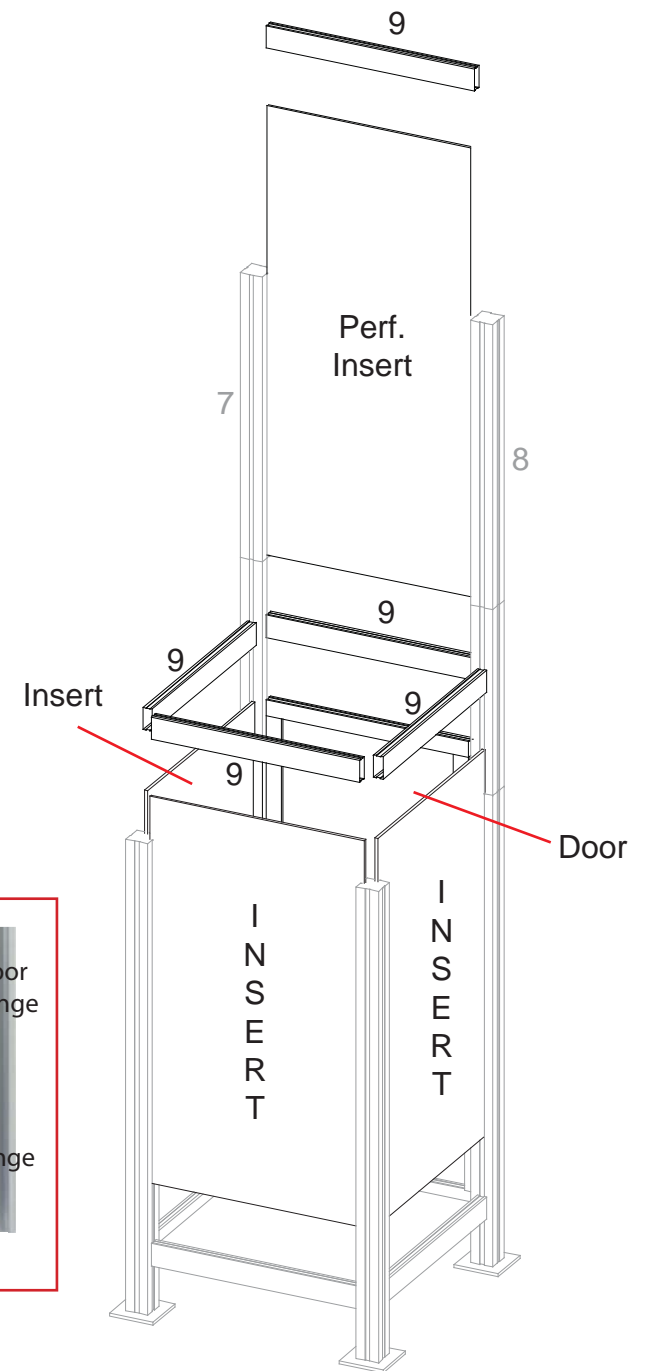
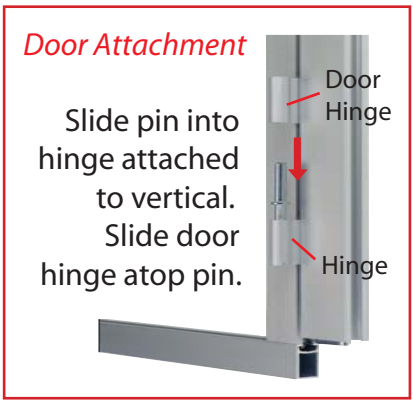

WHEN DISASSEMBLING ALUMINUM EXTRUSION, TIGHTEN ALL SETSCREWS AND LOCKS TO PREVENT LOSS DURING SHIPPING

866.652.2100

Item	Qty.	Description
10	1	18"h Vertical Extrusion

Steps:

- 1) Attach vertical extrusion [10] to top of counter top and Velcro ballot box to underside of counter.
- 2) Place counter top on assembled base.
- 3) Attach monitor mounts to assembled kiosk where indicated.

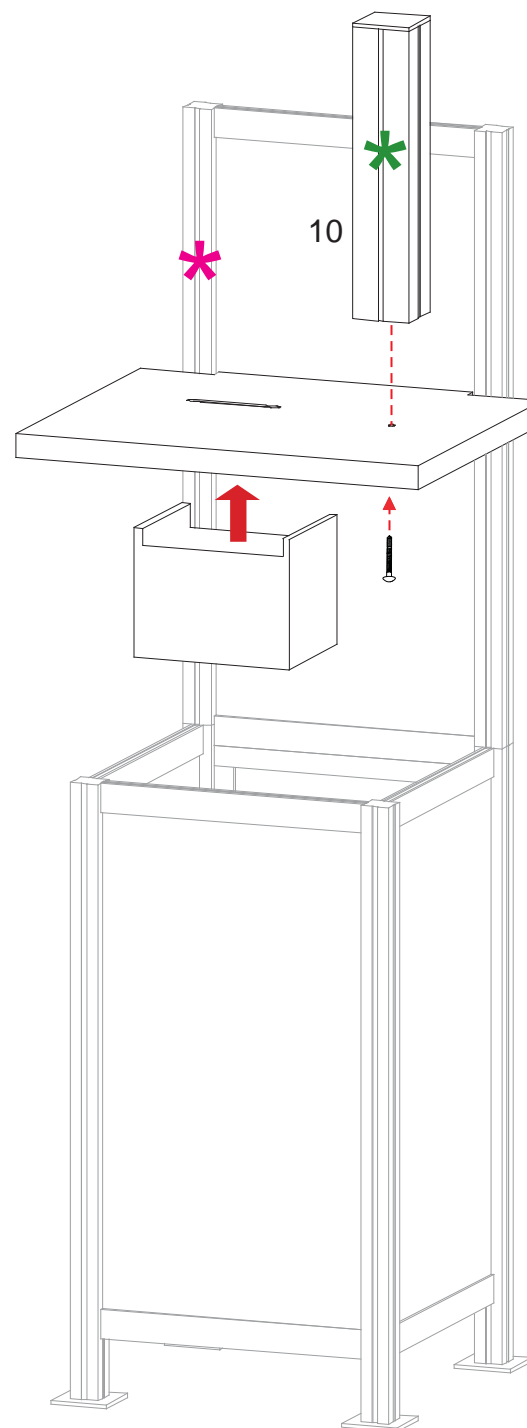
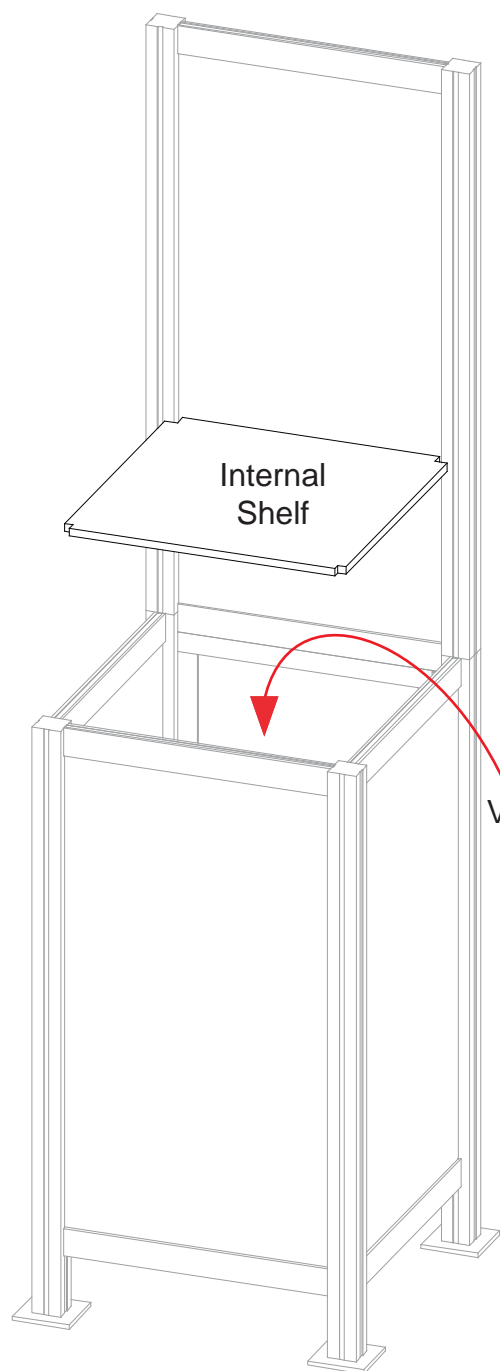

*** Small Monitor Mount Attachment**
Attach monitor mount to vertical extrusions after assembly.



Slide Mount into Groove of Vertical Extrusion. Tighten Setscrew Attach top Plate and tighten screws

*** Example of Large Monitor Mount Plate**

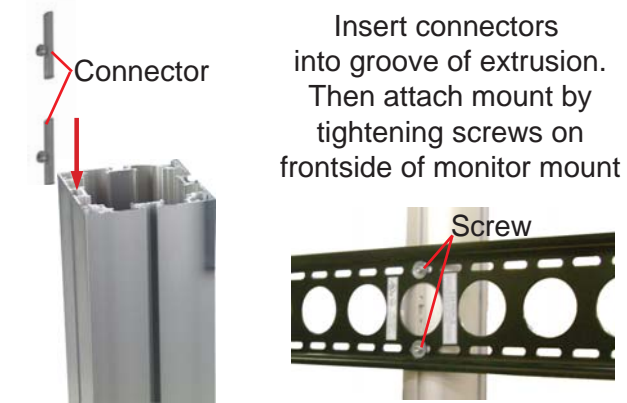

Insert connectors into groove of extrusion. Then attach mount by tightening screws on frontside of monitor mount

WHEN DISASSEMBLING ALUMINUM EXTRUSION, TIGHTEN ALL SETSCREWS AND LOCKS TO PREVENT LOSS DURING SHIPPING

Steps:

- 1) Attach literature pockets to vertical extrusion, see Literature Pocket Attachment Detail.
- 2) Velcro headers to assembled kiosk.
- 3) Attach wing to assembled kiosk where indicated using A10 clamps as shown.

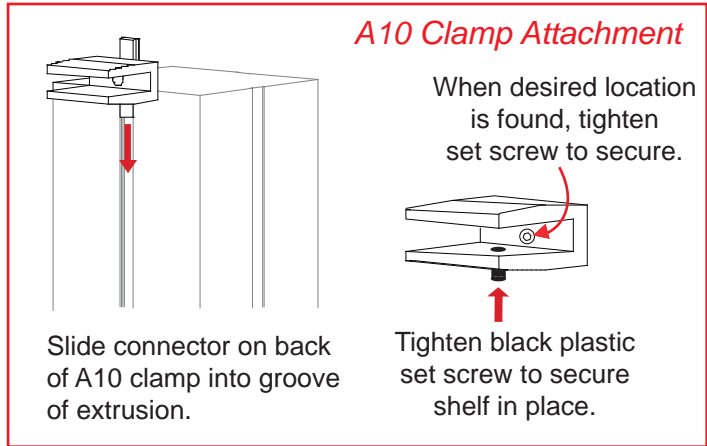
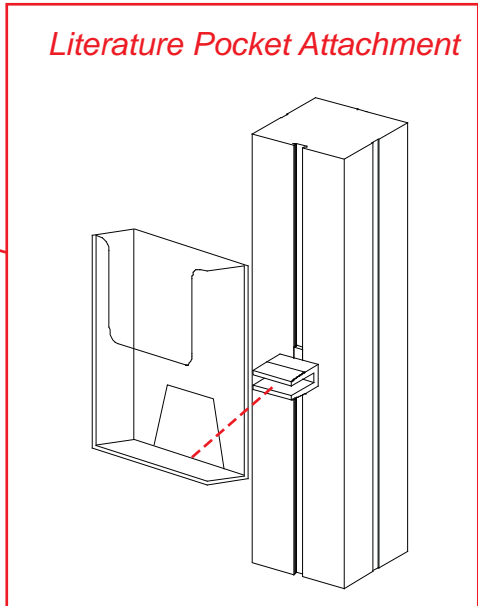
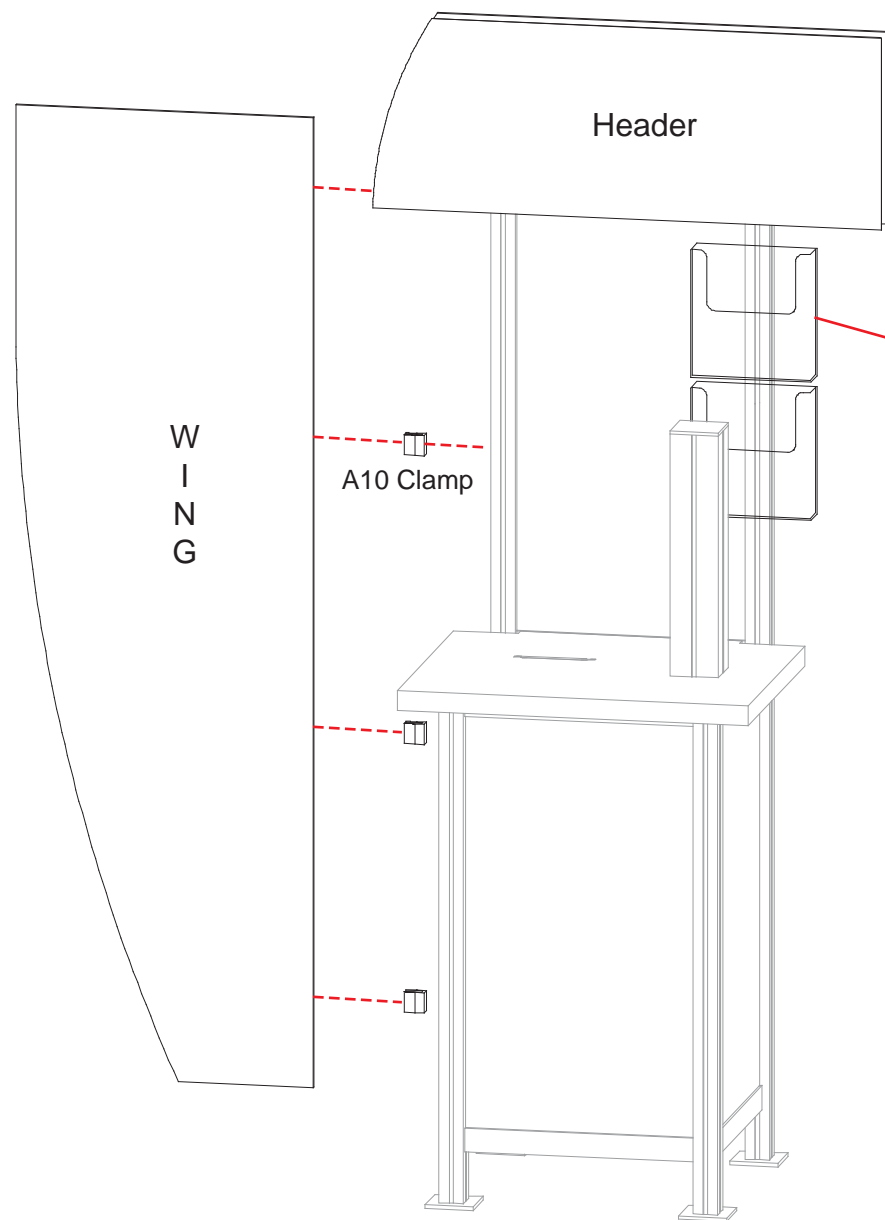

WHEN DISASSEMBLING ALUMINUM EXTRUSION, TIGHTEN ALL SETSCREWS AND LOCKS TO PREVENT LOSS DURING SHIPPING

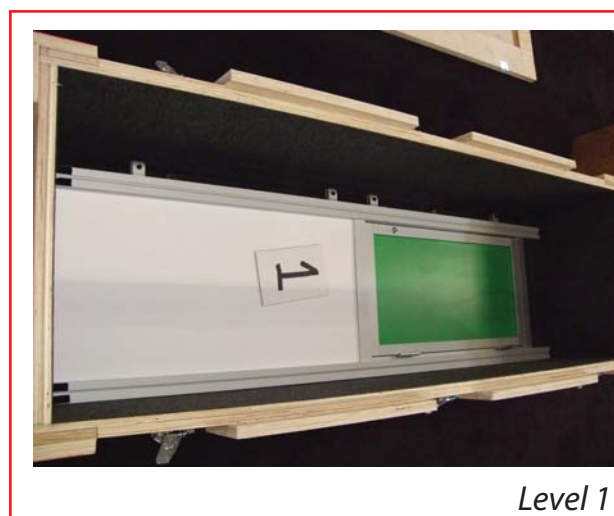
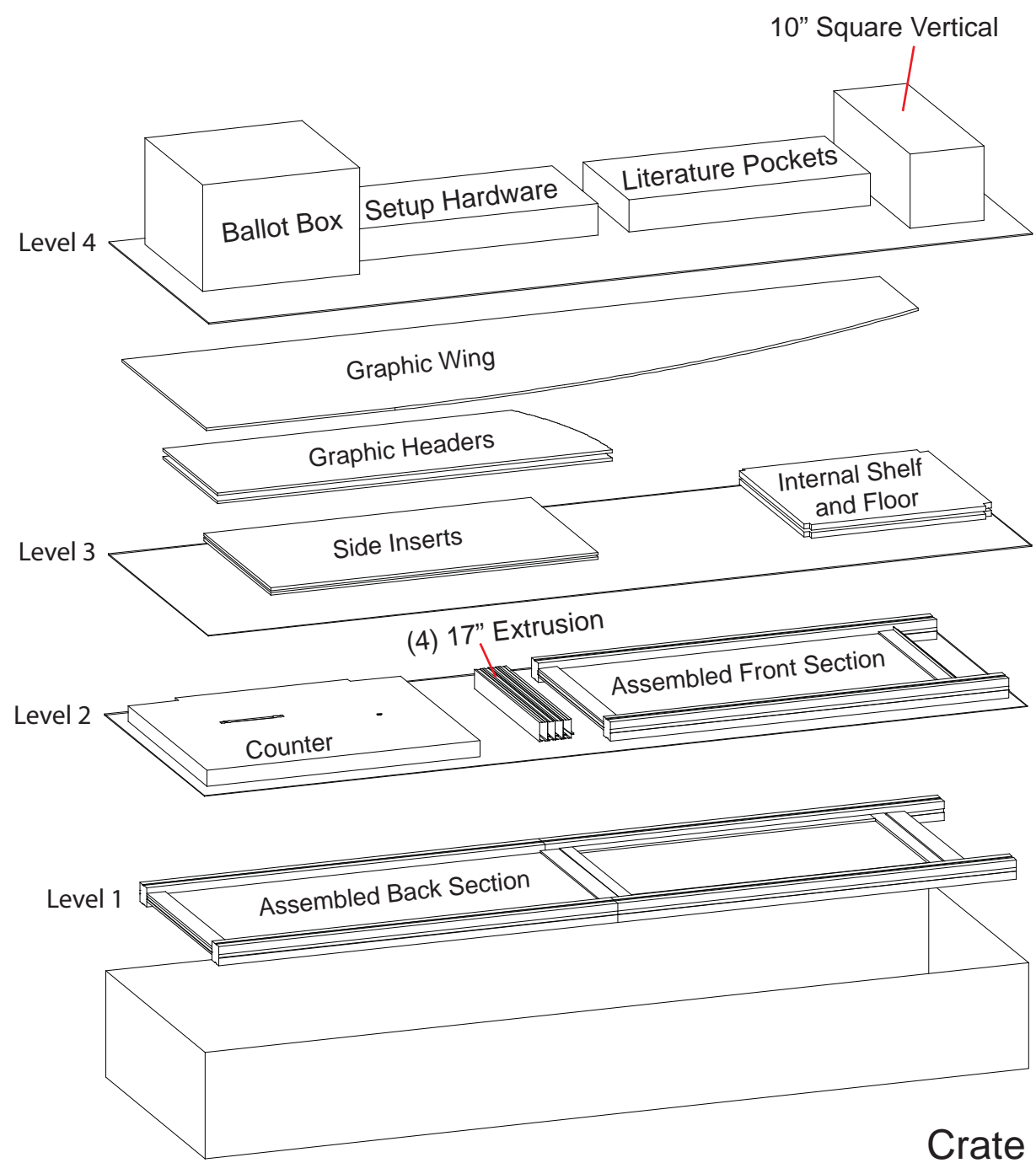

WHEN DISASSEMBLING ALUMINUM EXTRUSION, TIGHTEN ALL SETSCREWS AND LOCKS TO PREVENT LOSS DURING SHIPPING