

WHEN DISASSEMBLING ALUMINUM EXTRUSION, TIGHTEN ALL SETSCREWS AND LOCKS TO PREVENT LOSS DURING SHIPPING

# visionary™ IDESIGNS

## Using Your Setup Instructions

The Visionary Designs Setup Instructions are created specifically for your configuration. They are laid out sequentially, including an exploded view of the entire display, and then a logical series of detailed steps to assemble the main structure and components. We encourage you to study the instructions **before** attempting to assemble your exhibit.

Each page reminds you to tighten the setscrews after disassembling your exhibit to prevent loss of the locks and setscrews (see below in RED). This is **VERY IMPORTANT**.

## Cleaning and Packing Your Display

- 1) Use care when cleaning aluminum extrusion or acrylic inserts. Use only non-abrasive cleaners.
- 2) When cleaning laminate inserts or countertops, use mild cleansers and a soft material such as cotton.
- 3) Keep all display components away from extreme heat and long exposure to sunlight to avoid warping and fading.
- 4) Retain all packing material. It will make re-packing much easier and will reduce the likelihood of shipping damage.



**The Tool**

Most Visionary Designs exhibits can be assembled with the supplied Hex Key Tool. Occasionally, a flat head screwdriver may be required.



**Typical Connection**

Most horizontal extrusion connections have a patented expandable lock. This lock inserts into the groove of an opposing extrusion. Tightening the lock with the Hex Key Tool expands the lock and creates a strong positive connection.



**Typical Connection (cont'd)**

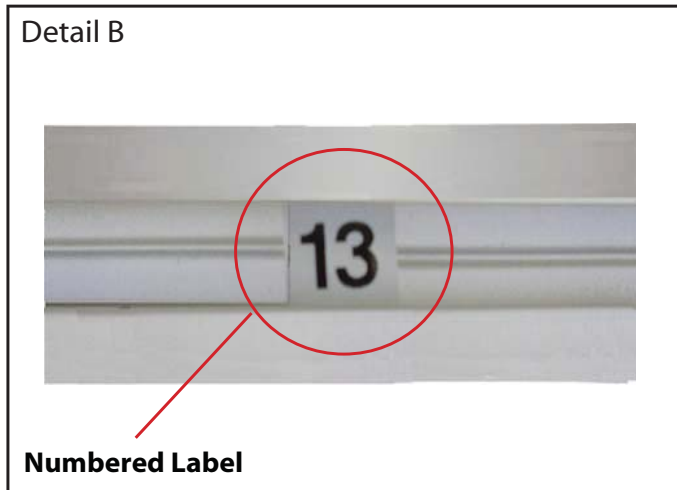

**Detail B**

**Numbered Label**

Each extrusion contains a numbered label which corresponds with setup instructions. The label is located within a groove of the extrusion (when possible). With Visionary Designs the labels contain Black numbers unless otherwise specified.



**Detail C**

**Horizontal Inline Connection** (remove only one setscrew)

Remove only (1) setscrew when disassembling. Replace setscrew in extrusion after assembling it. Before packing, replace setscrew in extrusion to avoid losing it.

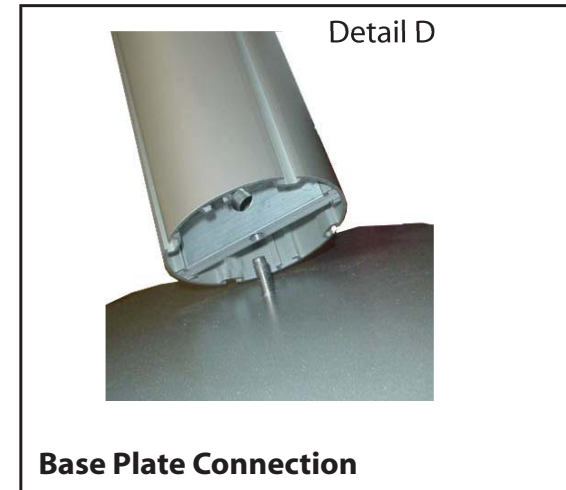

**Detail D**

**Base Plate Connection**

Attach base plate to round or square vertical extrusion using the bolt provided. Be careful not to strip the threads.

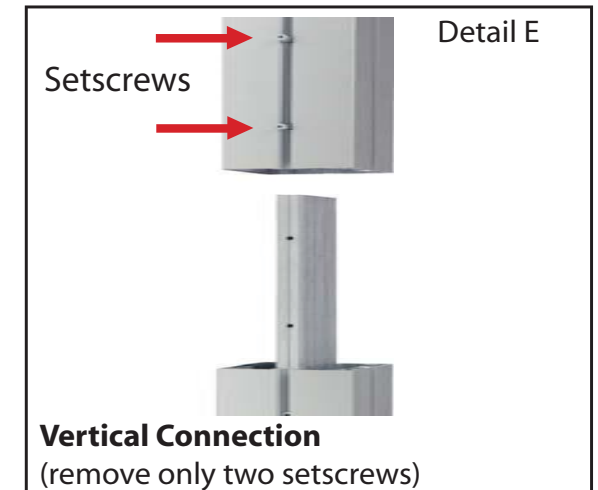

**Detail E**

**Vertical Connection**  
(remove only two setscrews)

When vertical extrusions are packed in portable cases rather than crates or tubs, they must be broken down into smaller sections which then require assembly.

Remove only (2) setscrews when disassembling. Replace setscrews in extrusion after assembling it. Before packing, replace setscrews in extrusion to avoid losing them.

**WHEN DISASSEMBLING ALUMINUM EXTRUSION, TIGHTEN ALL SETSCREWS AND LOCKS TO PREVENT LOSS DURING SHIPPING**

Item	Qty.	Description
1	1	Oval Base Plates
2	1	84"h Vertical Extrusion w/ Canopy Attachment
3	1	84"h Vertical Extrusion
4	1	84"h Vertical Extrusion w/ Canopy Attachment
5A/5B	1/1	28" Horizontal Extrusion
6A/6B	1/1	52" Horizontal Extrusion

**Steps**

- 1) Attach Vertical extrusion [4] to the Oval base plate [1].
- 2) Attach Horizontal extrusions [5A, 5B, 6A and 6B] between vertical extrusions [2, 3 and 4] as shown.

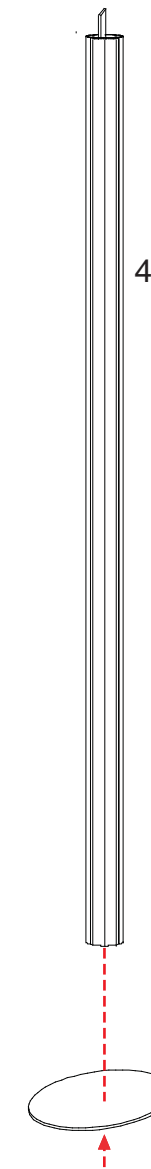
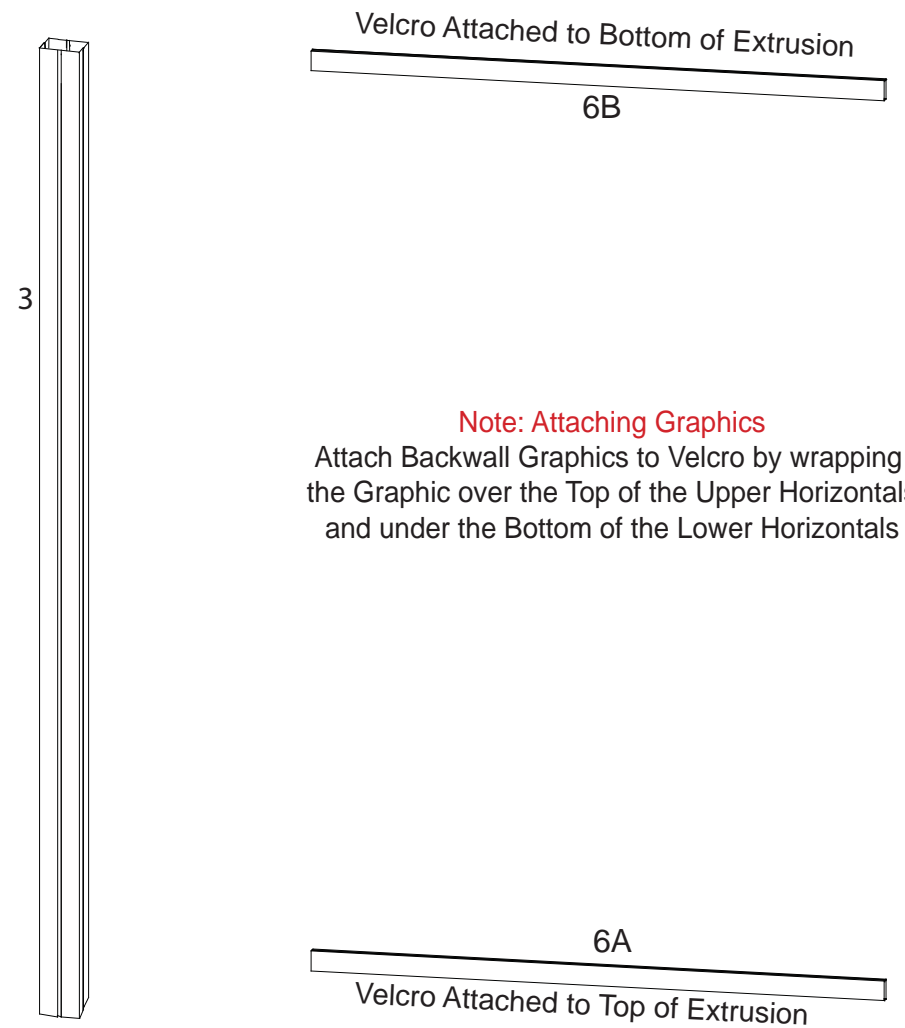
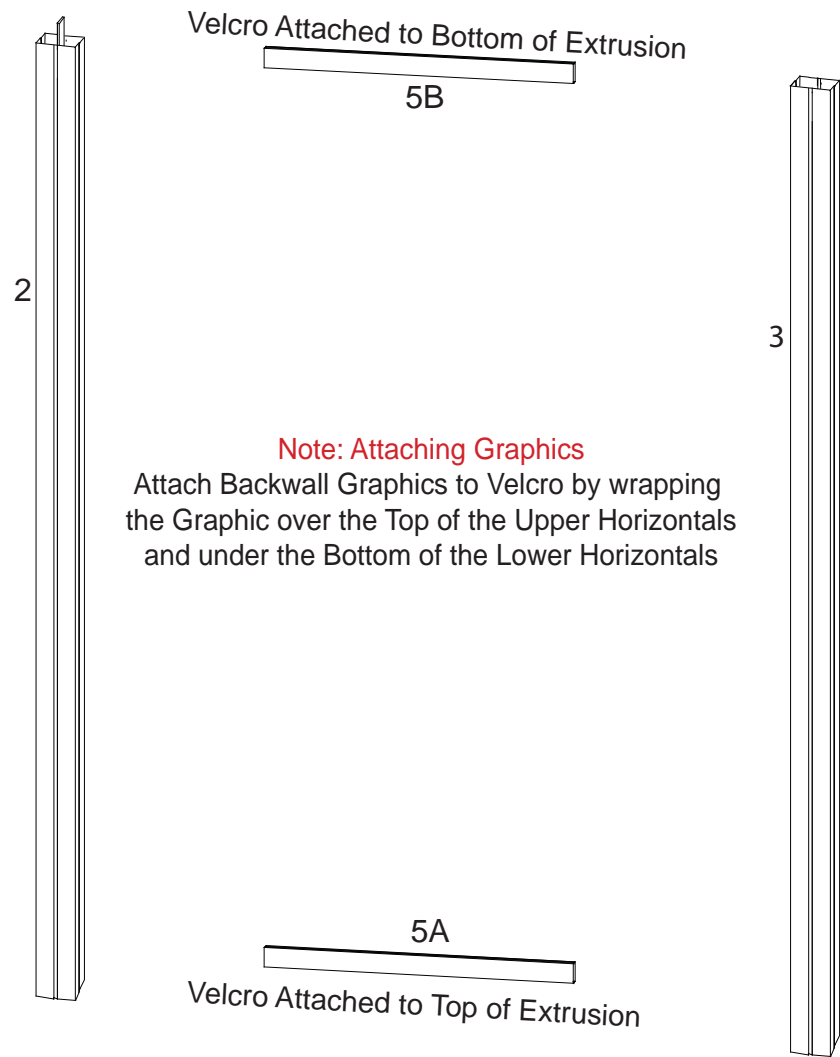
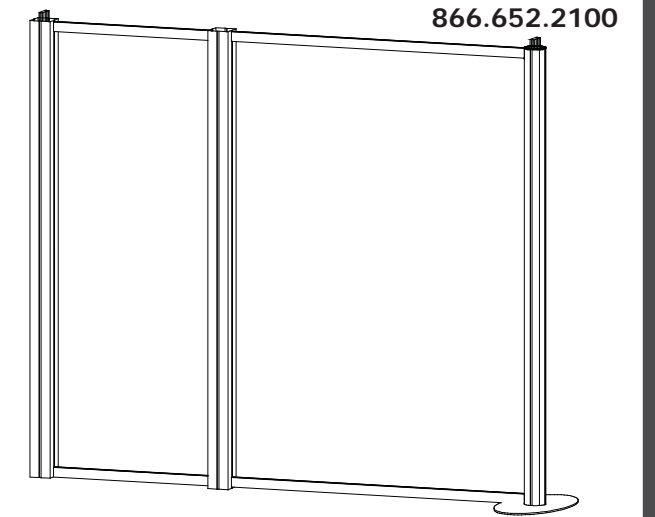

**WHEN DISASSEMBLING ALUMINUM EXTRUSION, TIGHTEN ALL SETSCREWS AND LOCKS TO PREVENT LOSS DURING SHIPPING**

866.652.2100

Item	Qty	Description
7/7A	1/1	38" h Round Vertical Extrusion
8	1	38" h 135° Vertical Extrusion w/ Door Stop
8A	1	38" h 135° Vertical Extrusion w/ Door Hinge
9	4	12.5" w Horizontal Extrusion
10	2	Curved Horizontal Extrusion
	4	Internal Shelf Support

Steps

- 1) Attach 135° extrusions to round vertical extrusions [8 to 7 and 7A to 8A] as shown below.  
**NOTE:** Extrusions [7/8 and 7A/8A] should remain assembled when shipping.
- 2) Attach lower horizontal extrusions [9 and 10] between vertical extrusions [8 and 8A] as shown.
- 3) Place inserts and door where indicated.
- 4) Attach upper horizontal extrusions [9 and 10] between vertical extrusions [7 and 7A] as shown.
- 5) Insert internal shelf and set atop velcroed supports.
- 6) Place counter atop assembled pedestal.

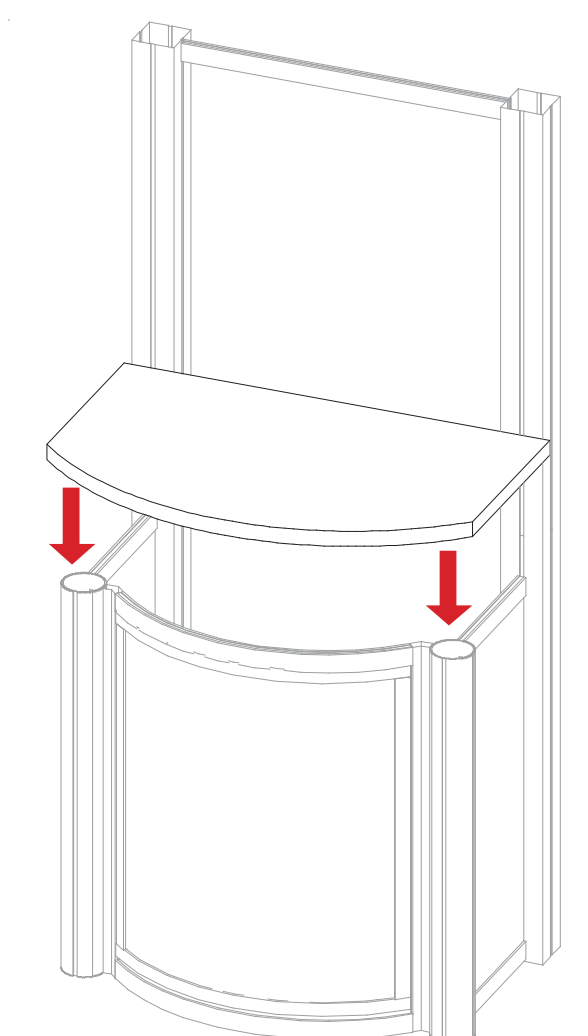
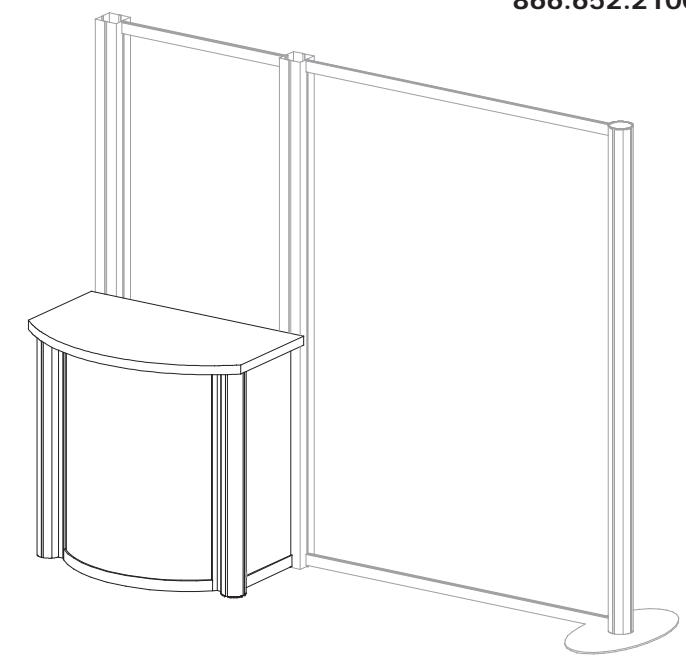
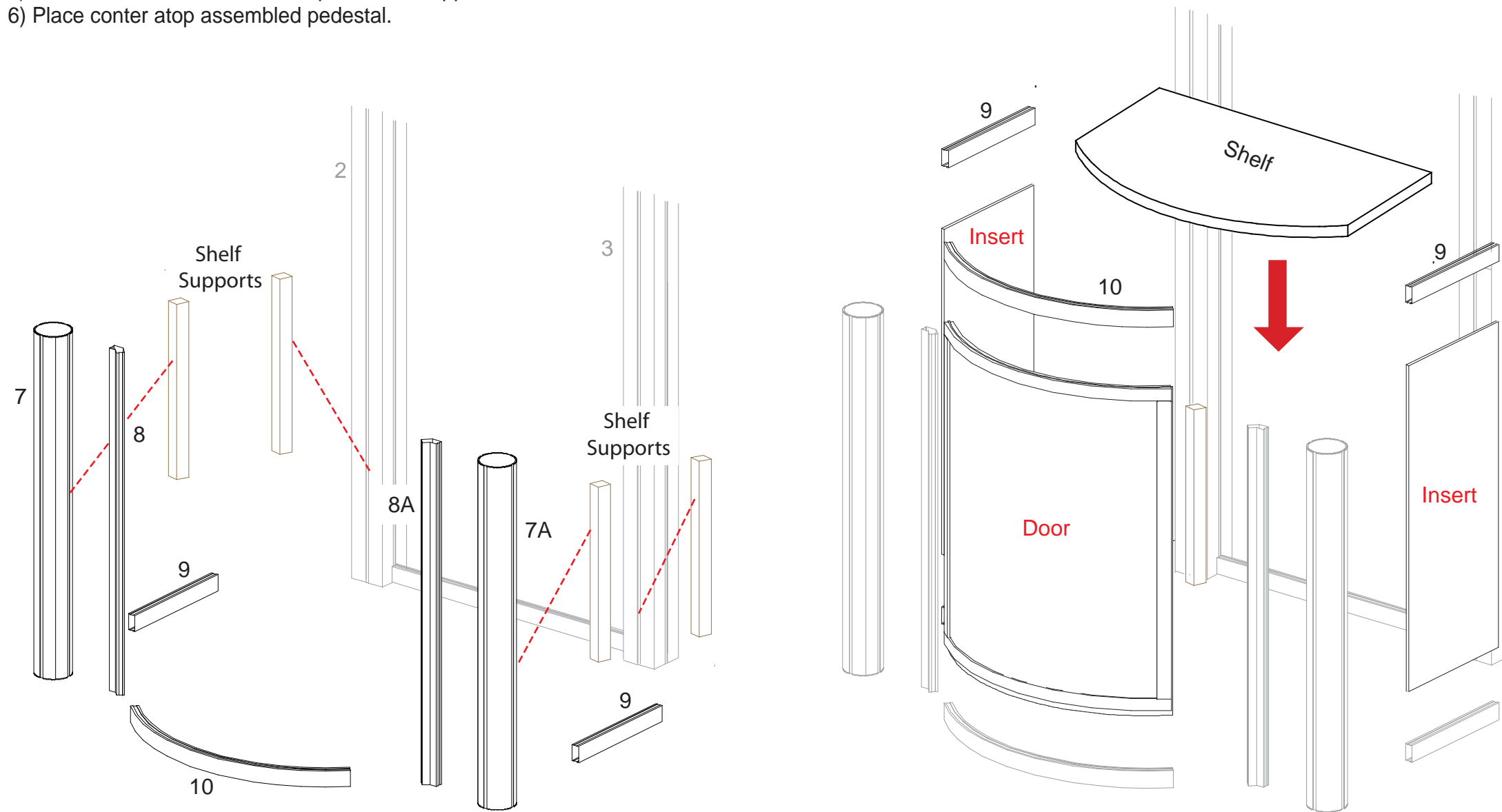

WHEN DISASSEMBLING ALUMINUM EXTRUSION, TIGHTEN ALL SETSCREWS AND LOCKS TO PREVENT LOSS DURING SHIPPING

Item	Qty.	Description
11	1	5.862"w Vertical Extrusion
12	1	5.862"w Vertical Extrusion
13	1	80.638"w Formed Horizontal Extrusion
14	1	78"w Horizontal Extrusion

**Steps**

- 1) Connect vertical extrusions [11 and 12] to left and right side of horizontal extrusion [14].
- 2) Attach formed horizontal extrusion [13] atop vertical extrusions [11 and 12].
- 3) Attach header to assembled backwall as shown.
- 4) Attach Sign using standoff barrels and caps.
- 5) Attach wings using A10 clamps as shown.
- 6) Attach monitor mount to assembled backwall, see monitor mount attachment detail.

Velcro attached to back of header extrusions

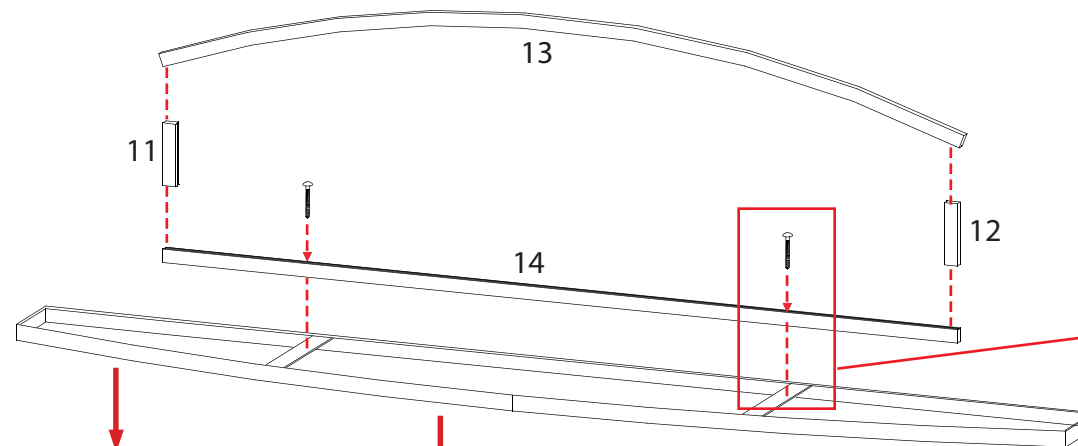

**Header Attachment**



Attach extrusion [14] to wood ceiling using screws and key wrench provided and secure with wing nuts

**Monitor Mount Attachment**

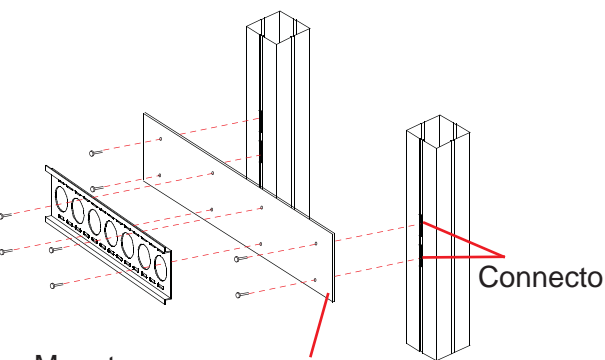

Monitor Mount Wall Plate  
Metal Plate  
Connectors

Connectors should remain attached to vertical extrusion when shipping.

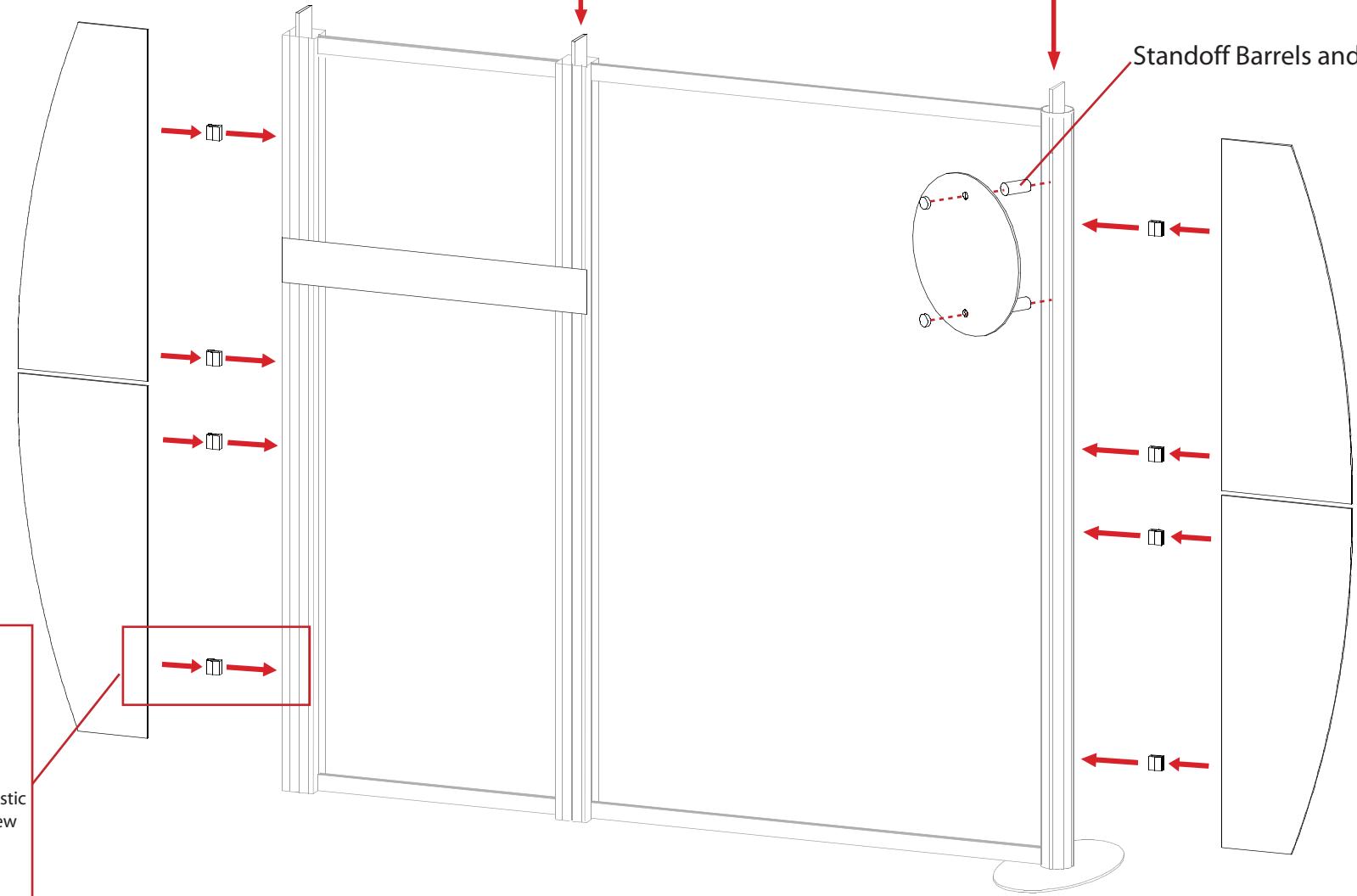

**Sign Attachment**



stand off barrel

Slide stand off barrels into groove of backwall extrusion

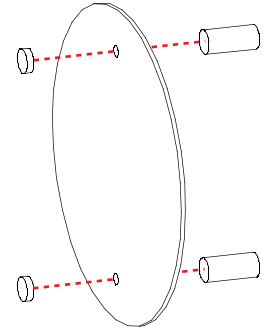

Secure Sign to stand off barrels using stand off caps

**Wing Attachment**

Slide A10 Clamp into groove of square extrusion.



When desired location is found, tighten set screw to secure.



Tighten black plastic set screw to secure Wing in place.



WHEN DISASSEMBLING ALUMINUM EXTRUSION, TIGHTEN ALL SETSCREWS AND LOCKS TO PREVENT LOSS DURING SHIPPING

Item	Qty.	Description
15	1	18"D Round Base Plate
16	1	80"h Round Vertical Extrusion
17	1	36"h Round Vertical Extrusion

**Steps**

- 1) Attach vertical extrusions [16 and 17] to base plate [15] as shown.
- 2) Attach tapered plex wing to front of vertical extrusion [17] using standoff caps and round sign to vertical extrusion [16].
- 3) Place and attach counter atop vertical extrusion [17].

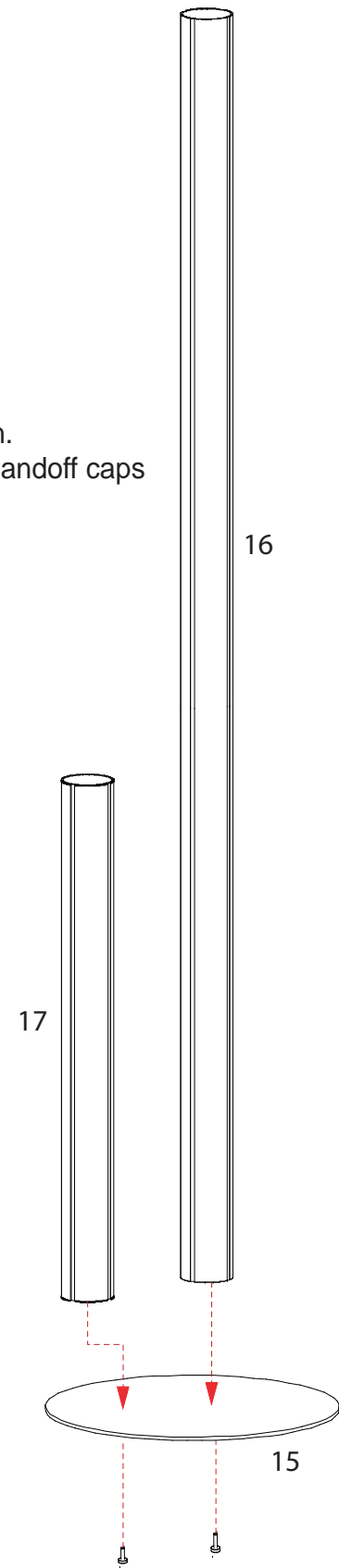

**Sign Attachment**

stand off barrel

Slide stand off barrels into groove of vertical extrusion

Secure Sign to stand off barrels using stand off caps

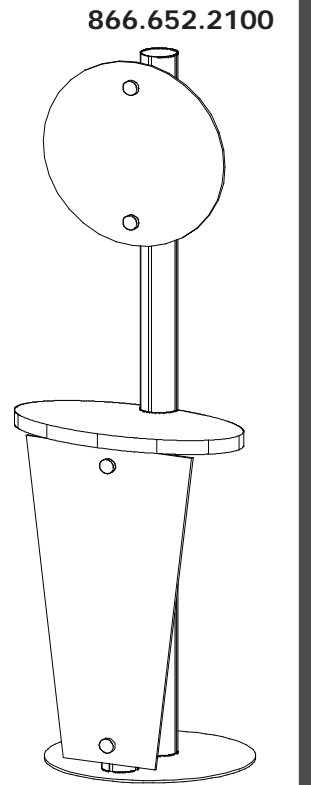
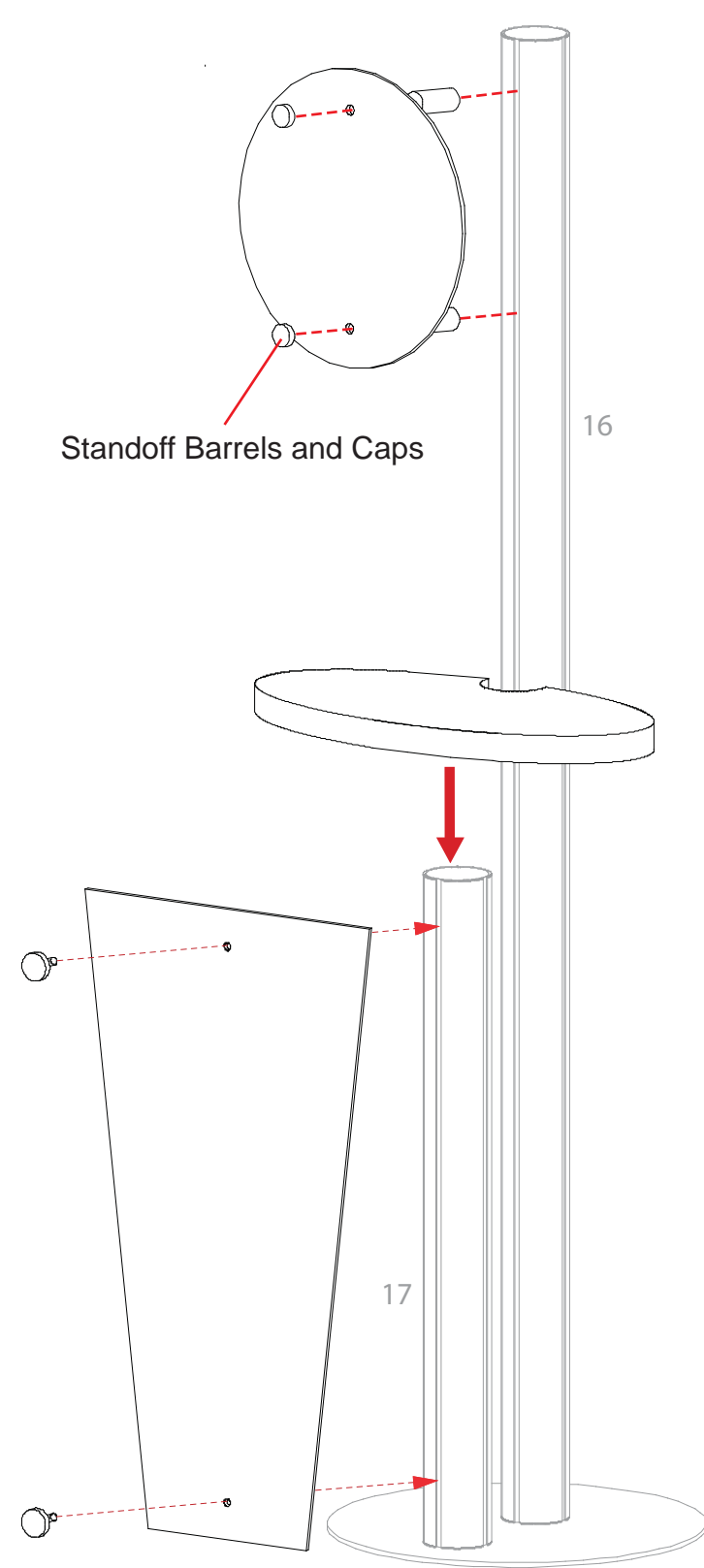

**WHEN DISASSEMBLING ALUMINUM EXTRUSION, TIGHTEN ALL SETSCREWS AND LOCKS TO PREVENT LOSS DURING SHIPPING**

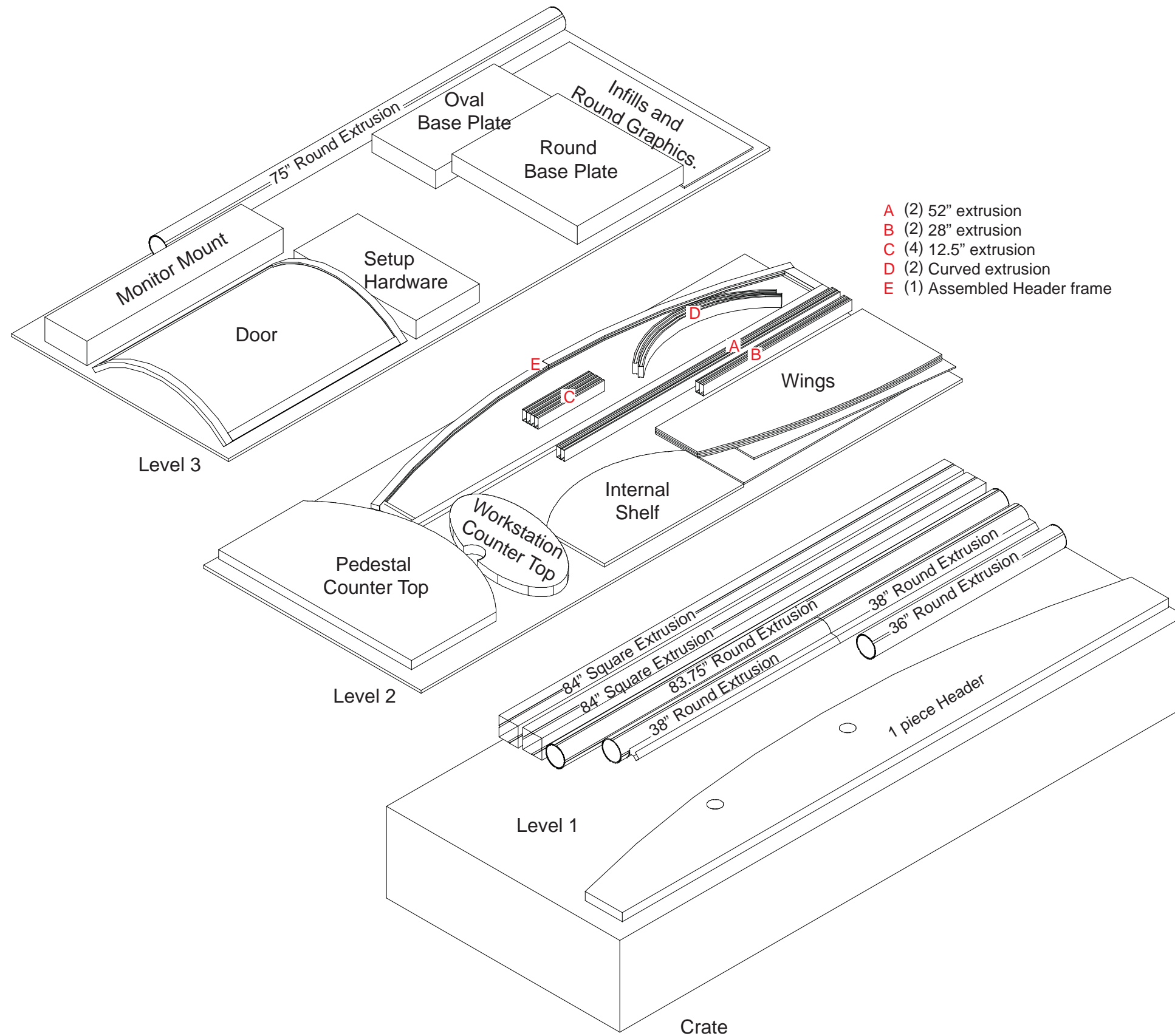

**WHEN DISASSEMBLING ALUMINUM EXTRUSION, TIGHTEN ALL SETSCREWS AND LOCKS TO PREVENT LOSS DURING SHIPPING**