

euro It | *HYBRIDS*

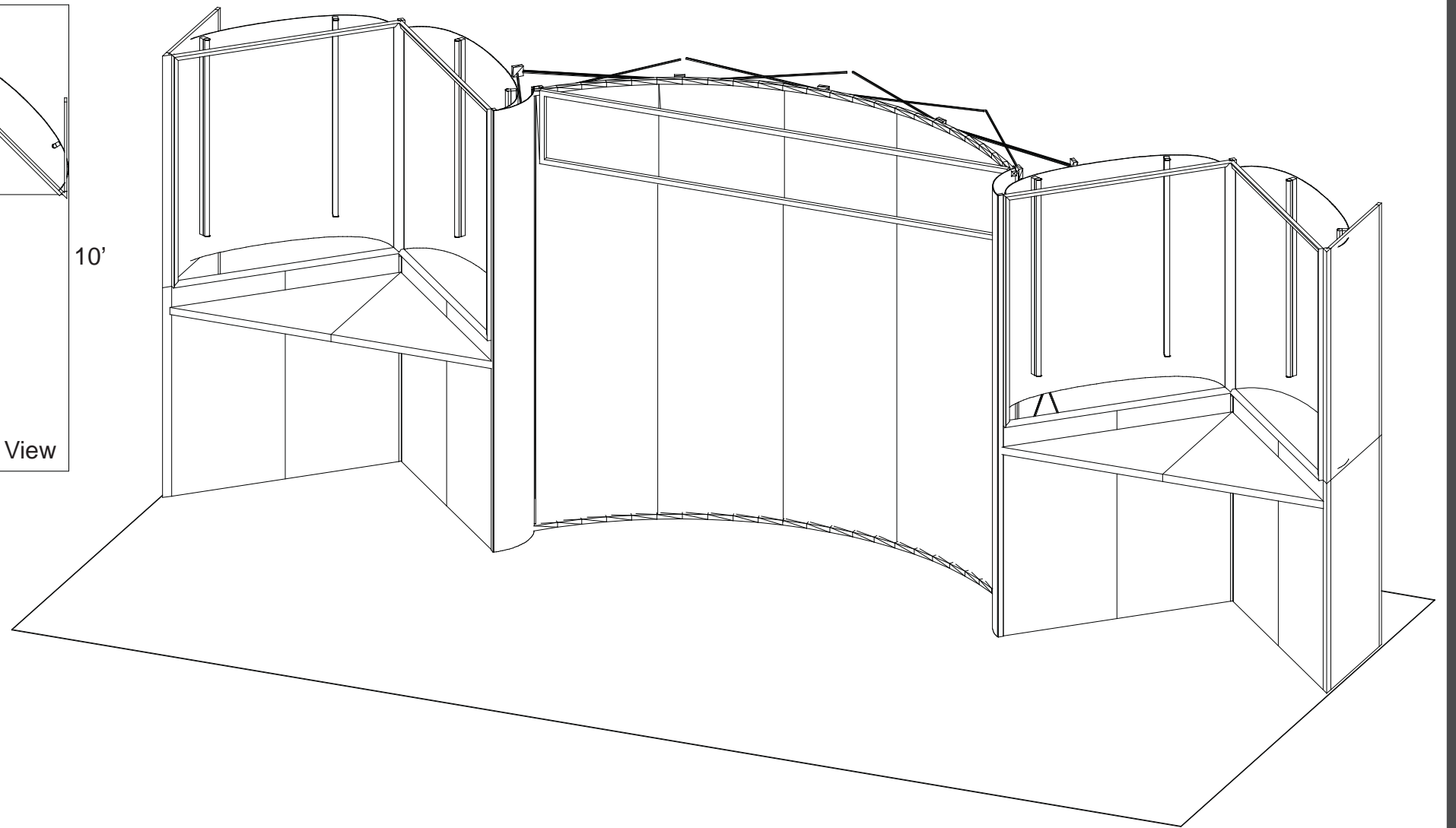
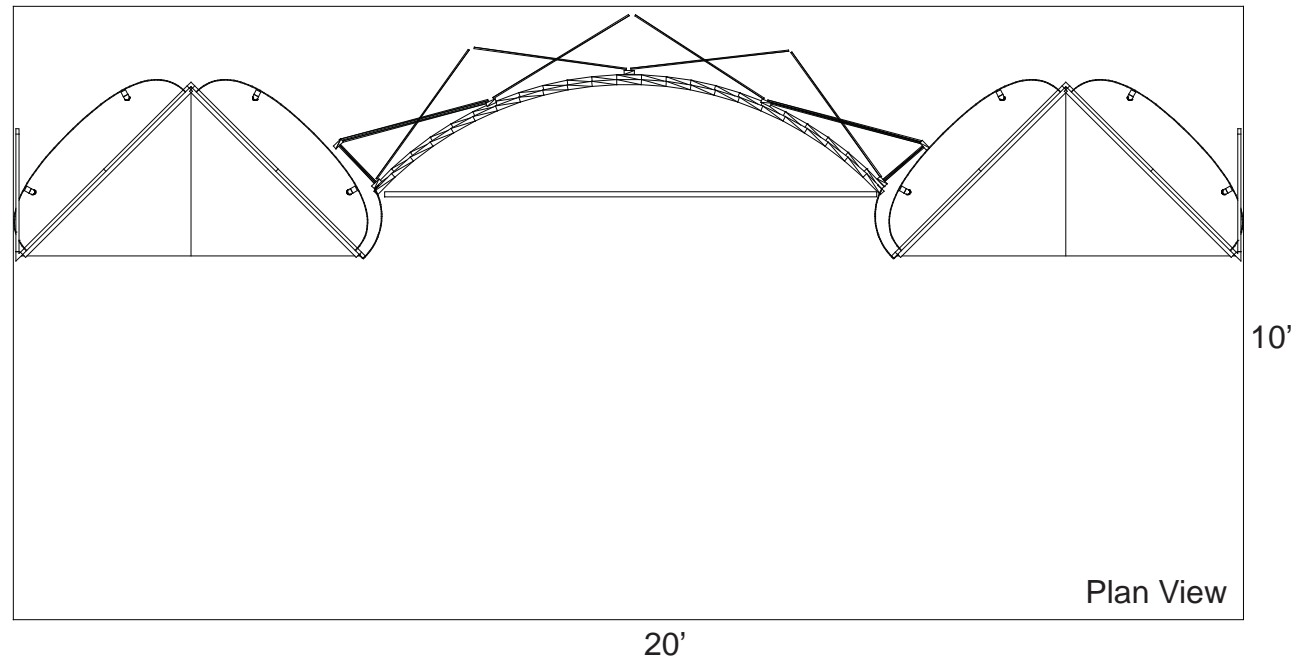

WHEN DISASSEMBLING ALUMINUM EXTRUSION, TIGHTEN ALL SETSCREWS AND LOCKS TO PREVENT LOSS DURING SHIPPING

euro lt | HYBRIDS

Using Your Setup Instructions

The Euro LT Hybrids Setup Instructions are created specifically for your configuration. They are laid out sequentially in levels, including exploded views, and a logical series of detailed steps to assemble the main structure and components. We encourage you to study the instructions **before** attempting to assemble your exhibit.

Each page reminds you to tighten the setscrews after disassembling your exhibit to prevent loss of the locks and setscrews (see below in RED). This is VERY IMPORTANT.

Cleaning and Packing Your Display

- 1) Use care when cleaning aluminum extrusion or acrylic inserts. Use only non-abrasive cleaners.
- 2) When cleaning laminate inserts, countertops, or panels use mild cleansers and a soft material such as cotton.
- 3) Keep all display components away from extreme heat and long exposure to sunlight to avoid warping and fading.
- 4) Retain all packing material. It will make re-packing much easier and will reduce the likelihood of shipping damage.

General Setup Instructions for Extrusion System



Most exhibits can be assembled with the supplied Hex Key Tool. Occasionally, a flat head screwdriver may be required.



Most horizontal extrusion connections have a patented expandable lock. This lock inserts into the groove of an opposing extrusion. Tightening the lock with the Hex Key Tool expands the lock and creates a strong positive connection.

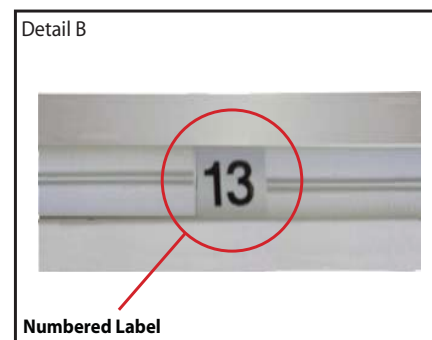

Each extrusion contains a numbered label which corresponds with setup instructions. The label is located within a groove of the extrusion (when possible). With extrusion components the labels contain Black numbers unless otherwise specified.



Remove only (1) setscrew when disassembling. Replace setscrew in extrusion after assembling it. Before packing, replace setscrew in extrusion to avoid losing it.

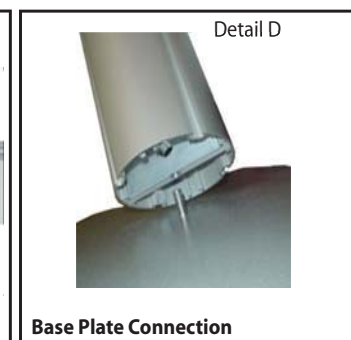

Attach base plate to round or square vertical extrusion using the bolt provided. Be careful not to strip the threads.

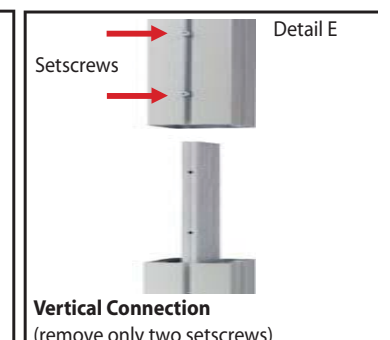

When vertical extrusions are packed in portable cases rather than crates or tubs, they must be broken down into smaller section which then require assembly.

Remove only (2) setscrews when disassembling. Replace setscrews in extrusion after assembling it. Before packing, replace setscrews in extrusion to avoid losing them.

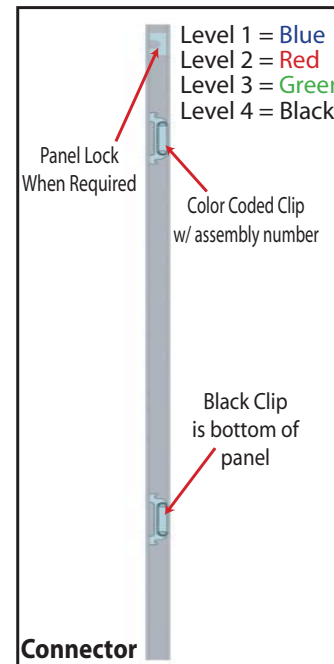

Each component has 2 clips, the lower clip is ALWAYS black. The top clip is color coded to distinguish which level. The color coded clip also contains the numbered label.

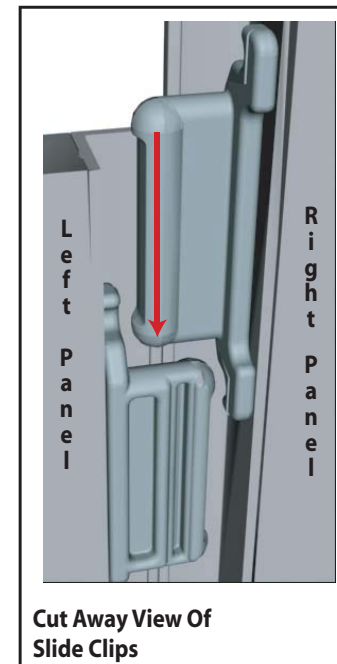

Components connect together by aligning them and sliding downward connecting clips together.

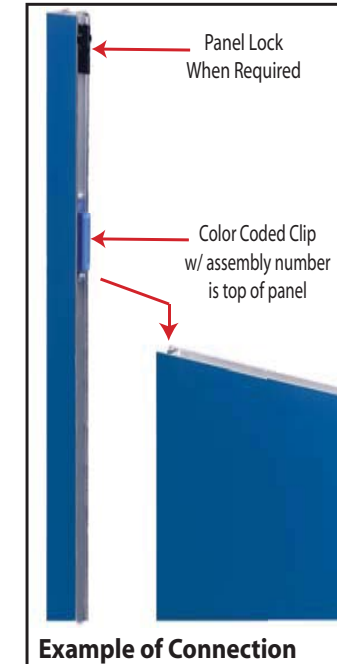

Configurations are assembled from left to right, usually starting with #1 and following the numbered sequence.

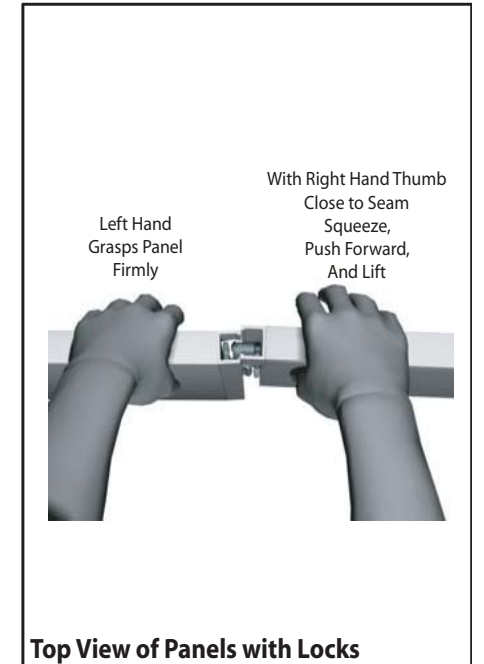

The first level of components contain panel locks that are located at the top of the panel for extra stability and seamless connection. When disassembling panels twist top connection slightly and lift right panel upward.

WHEN DISASSEMBLING ALUMINUM EXTRUSION, TIGHTEN ALL SETSCREWS AND LOCKS TO PREVENT LOSS DURING SHIPPING

866.652.2100

Item Number	Description	Item Number	Description
1	43" h End Cap	10	43" h Cap w/ Steel Tape Attached
2	23" w x 43" h Flat Panel	11	23" w x 43" h Flat Panel w/ Connector Attached
3	43" h 45° Connector	12	23" w x 43" h Flat Panel
4	23" w x 43" h Flat Panel w/ Connector Attached	13	43" h 90° Connector
5	23" w x 43" h Flat Panel	14	23" w x 43" h Flat Panel
6	43" h 90° Connector	15	23" w x 43" h Flat Panel w/ Connector Attached
7	23" w x 43" h Flat Panel	16	43" h 45° Connector
8	23" w x 43" h Flat Panel w/ Connector Attached	17	23" w x 43" h Flat Panel
9	43" h Cap w/ Steel Tape Attached	18	43" h End Cap

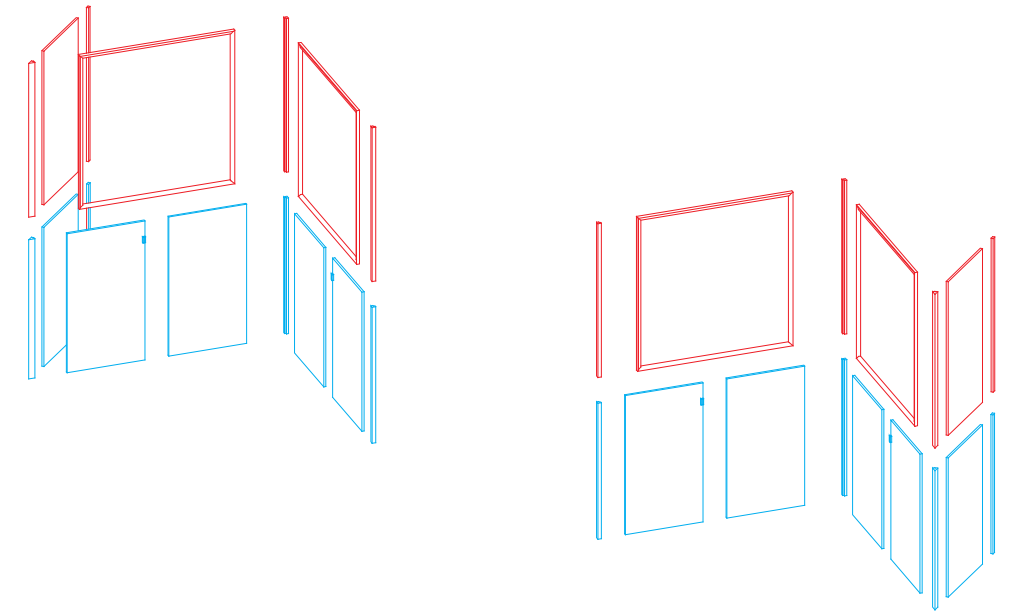

Steps:

- 1) Assemble by starting at panel #1* and continue in numerical order.

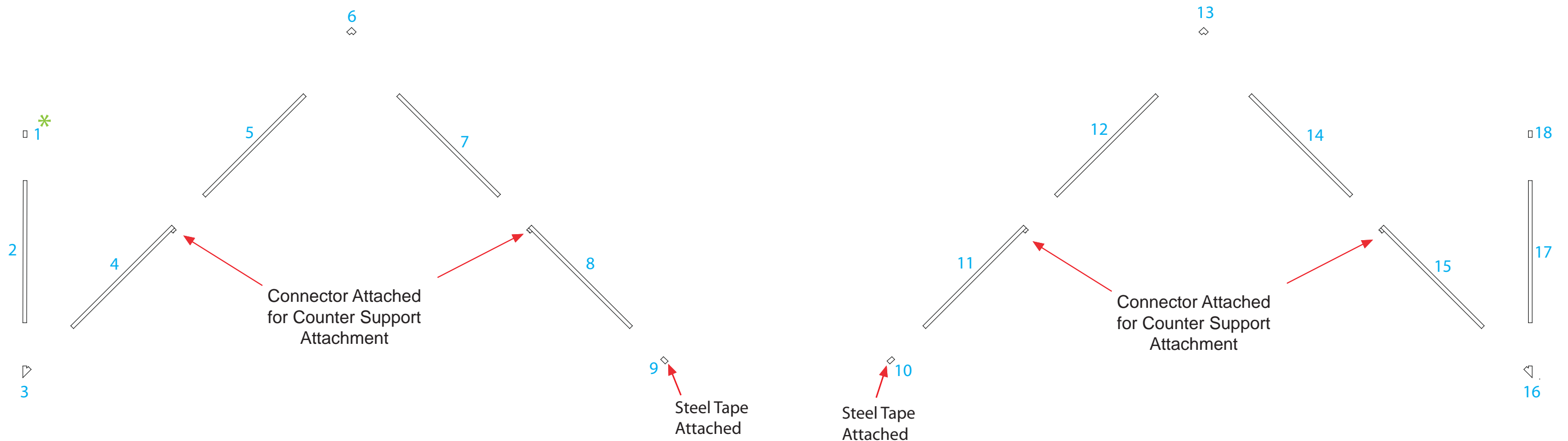

WHEN DISASSEMBLING ALUMINUM EXTRUSION, TIGHTEN ALL SETSCREWS AND LOCKS TO PREVENT LOSS DURING SHIPPING

Item Number	Description
1	47.5" h End Cap
2	23" w x 47.5" h Flat Panel
3	47.5" h 45° Connector
4/5	46" w x 47.5" h Light Box Frame
6	47.5" h 90° Connector
7/8	46" w x 47.5" h Light Box Frame
9	47.5" h Cap w/ Steel Tape Attached

Item Number	Description
10	47.5" h Cap w/ Steel Tape Attached
11/12	46" w x 47.5" h Light Box Frame
13	47.5" h 90° Connector
14/15	46" w x 47.5" h Light Box Frame
16	47.5" h 45° Connector
17	23" w x 47.5" h Flat Panel
18	47.5" h End Cap

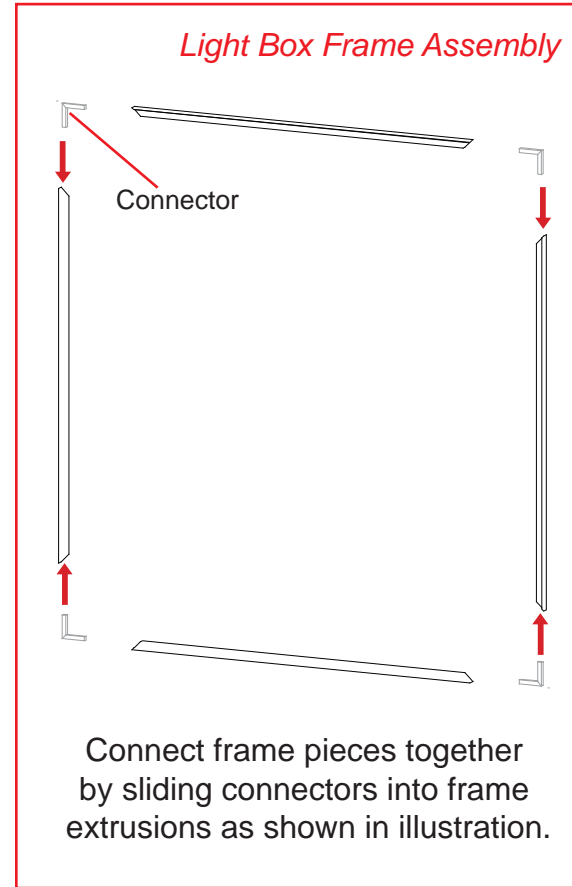
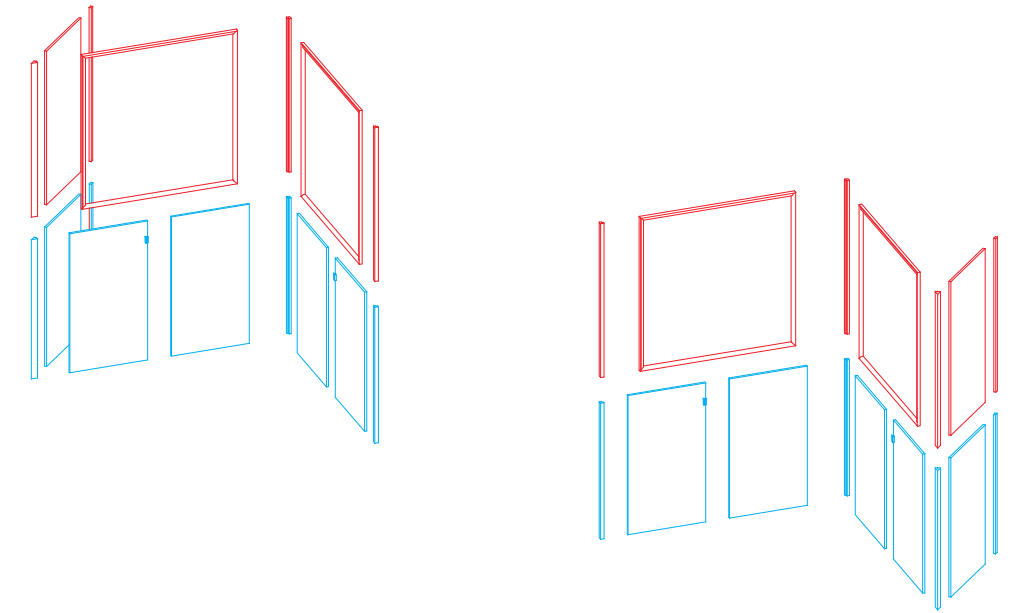

Steps:
 1) Connect light box frame pieces together, see Light Box Assembly.
 2) Assemble by starting at panel #1* and continue in numerical order.

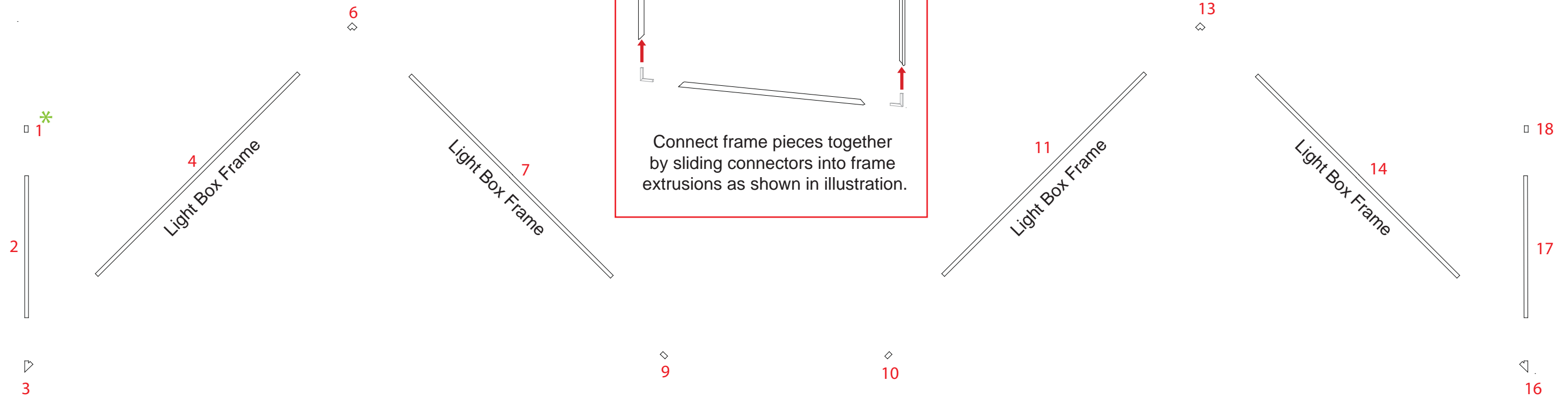

WHEN DISASSEMBLING ALUMINUM EXTRUSION, TIGHTEN ALL SETSCREWS AND LOCKS TO PREVENT LOSS DURING SHIPPING

866.652.2100

Item Number	Qty.	Description
1	2	Counter Support Extrusion

- Steps:
- 1) Attach counter support extrusions to connectors as shown.
 - 2) Place counter tops on supports and secure with thumbscrews where indicated.

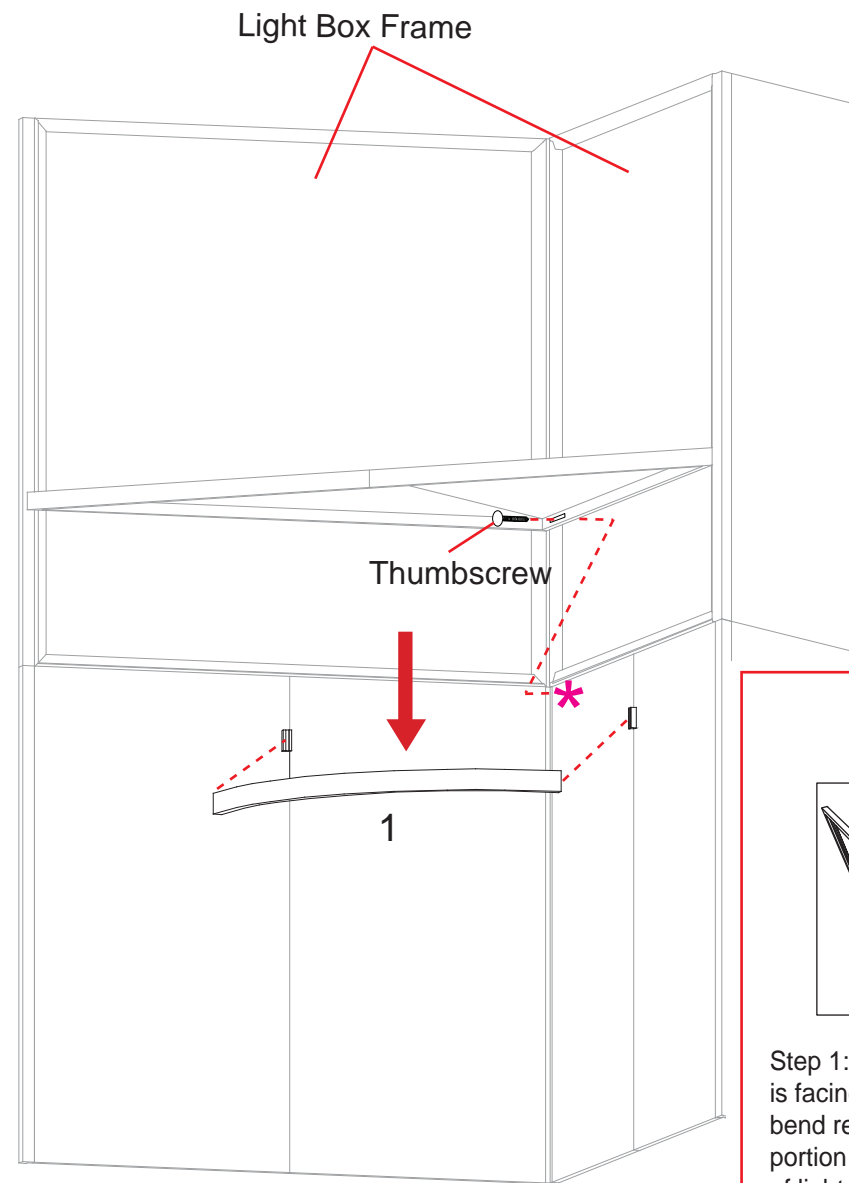
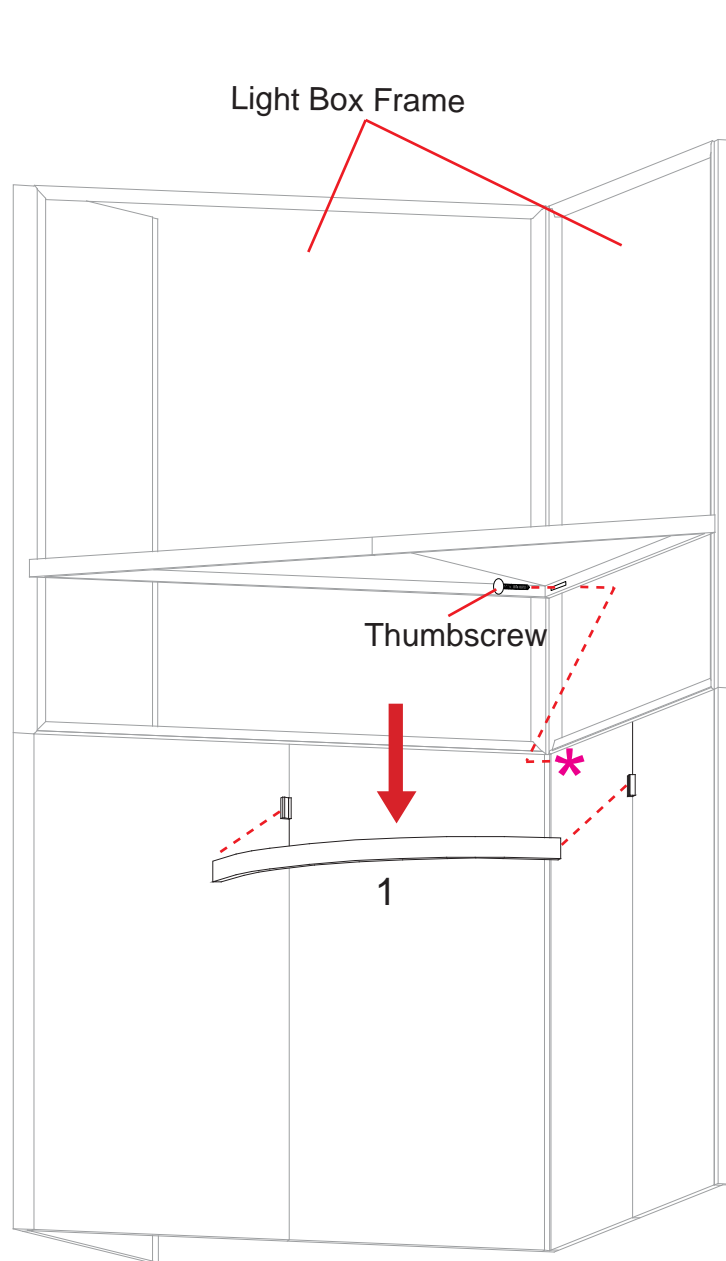
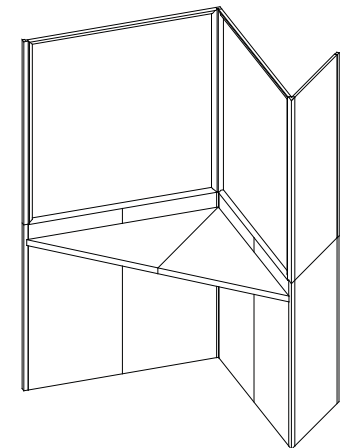
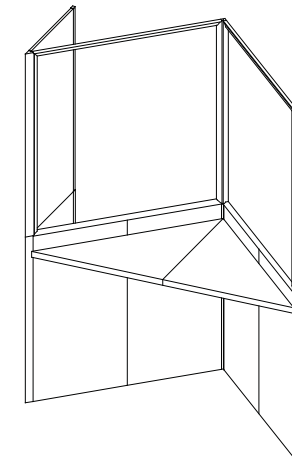

Light Box Assembly

Step 1: Making sure that velcro is facing to the front of the booth bend reflector and attach hinged portion to velcro attached to back of light box frame.

Step 2: Place light bars on velcro strips. Please note as every graphic is different some position adjustment may need to be made for optimum results.

Step 3: Using magnetic tape place graphic onto inside flange of frame.

WHEN DISASSEMBLING ALUMINUM EXTRUSION, TIGHTEN ALL SETSCREWS AND LOCKS TO PREVENT LOSS DURING SHIPPING

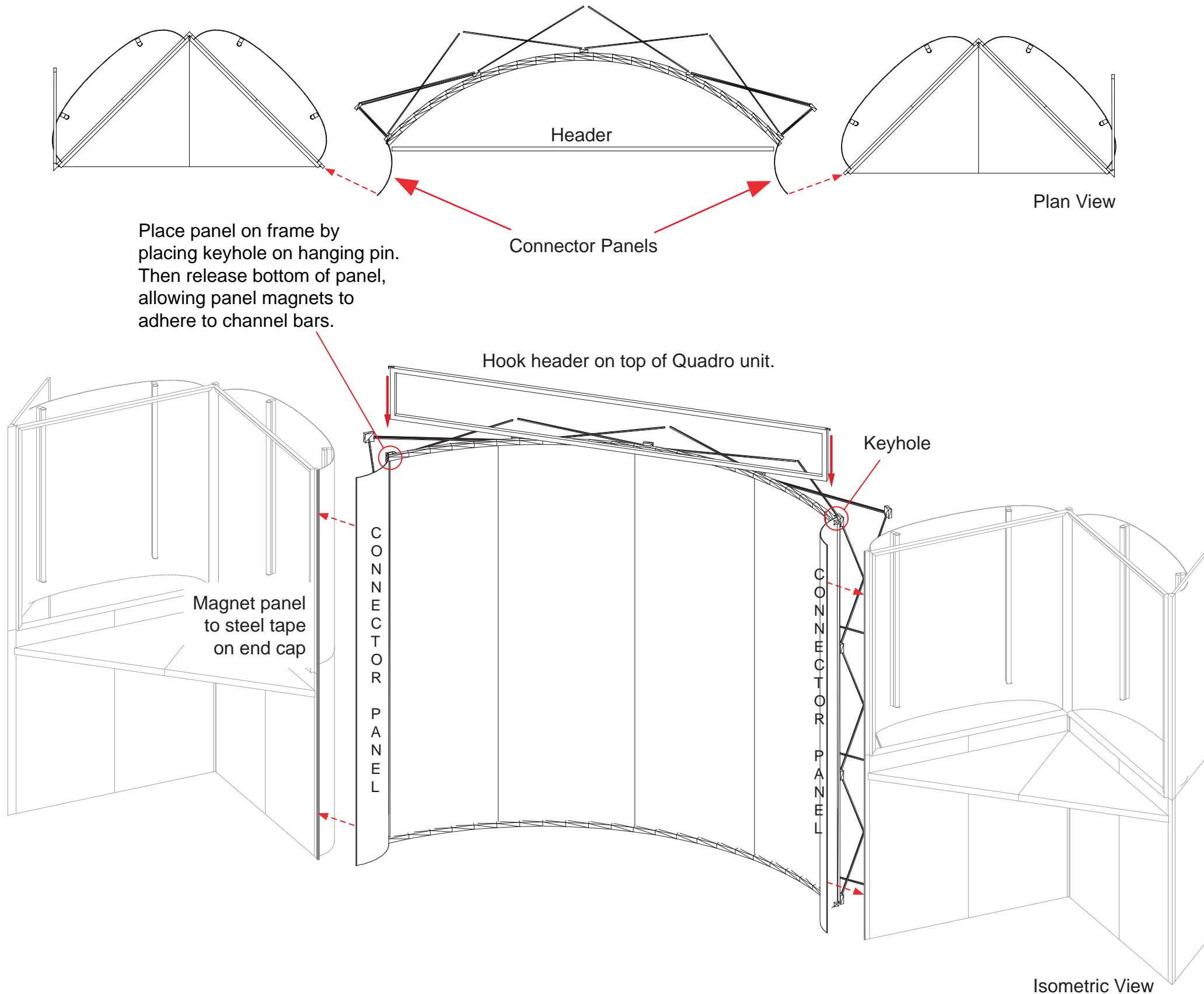

WHEN DISASSEMBLING ALUMINUM EXTRUSION, TIGHTEN ALL SETSCREWS AND LOCKS TO PREVENT LOSS DURING SHIPPING

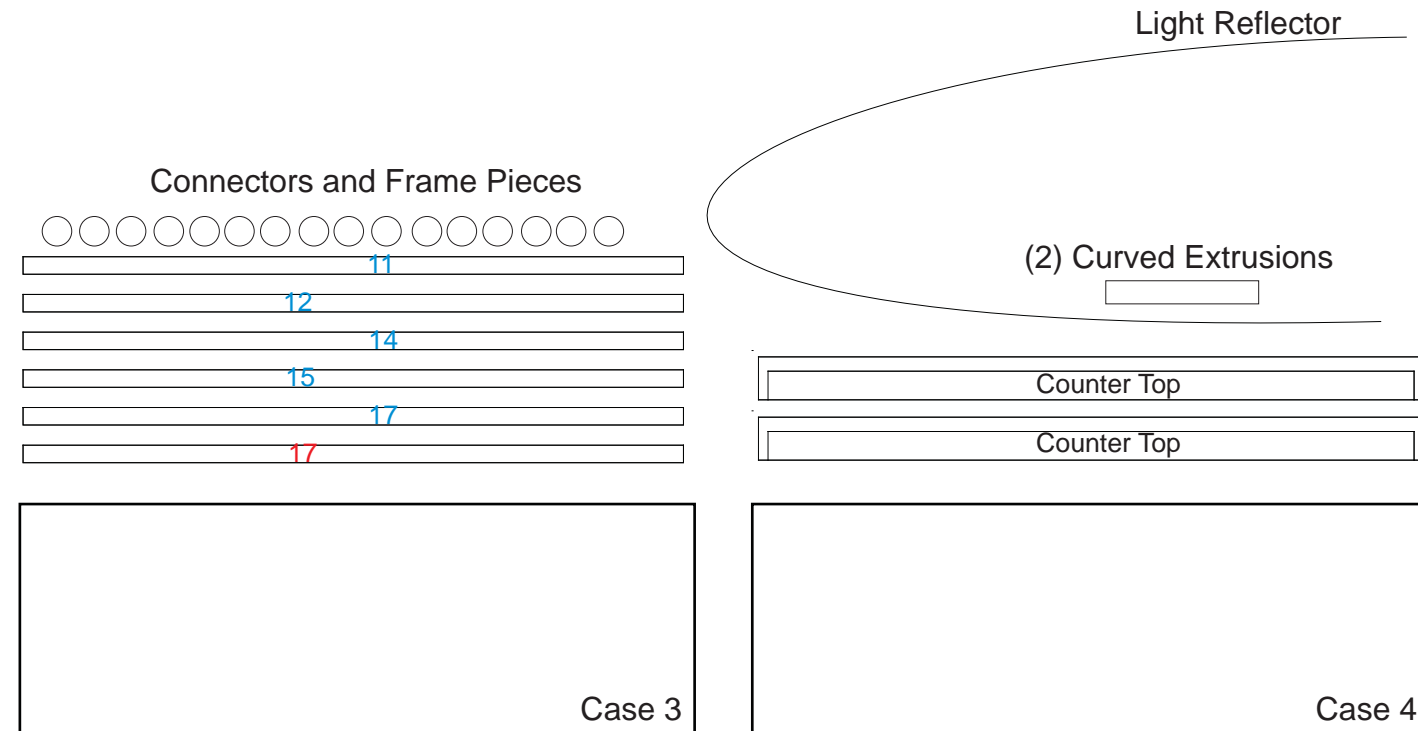
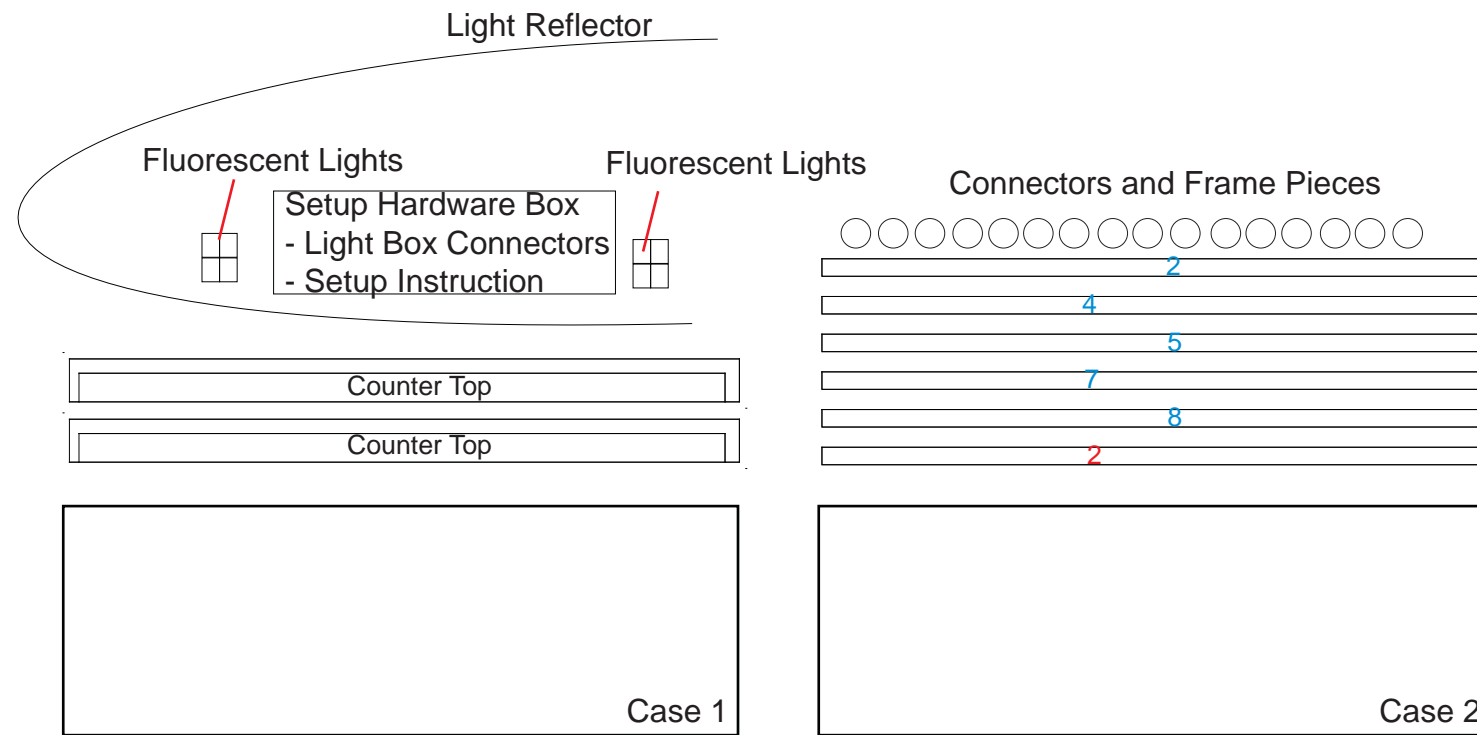

WHEN DISASSEMBLING ALUMINUM EXTRUSION, TIGHTEN ALL SETSCREWS AND LOCKS TO PREVENT LOSS DURING SHIPPING