

10'

10'

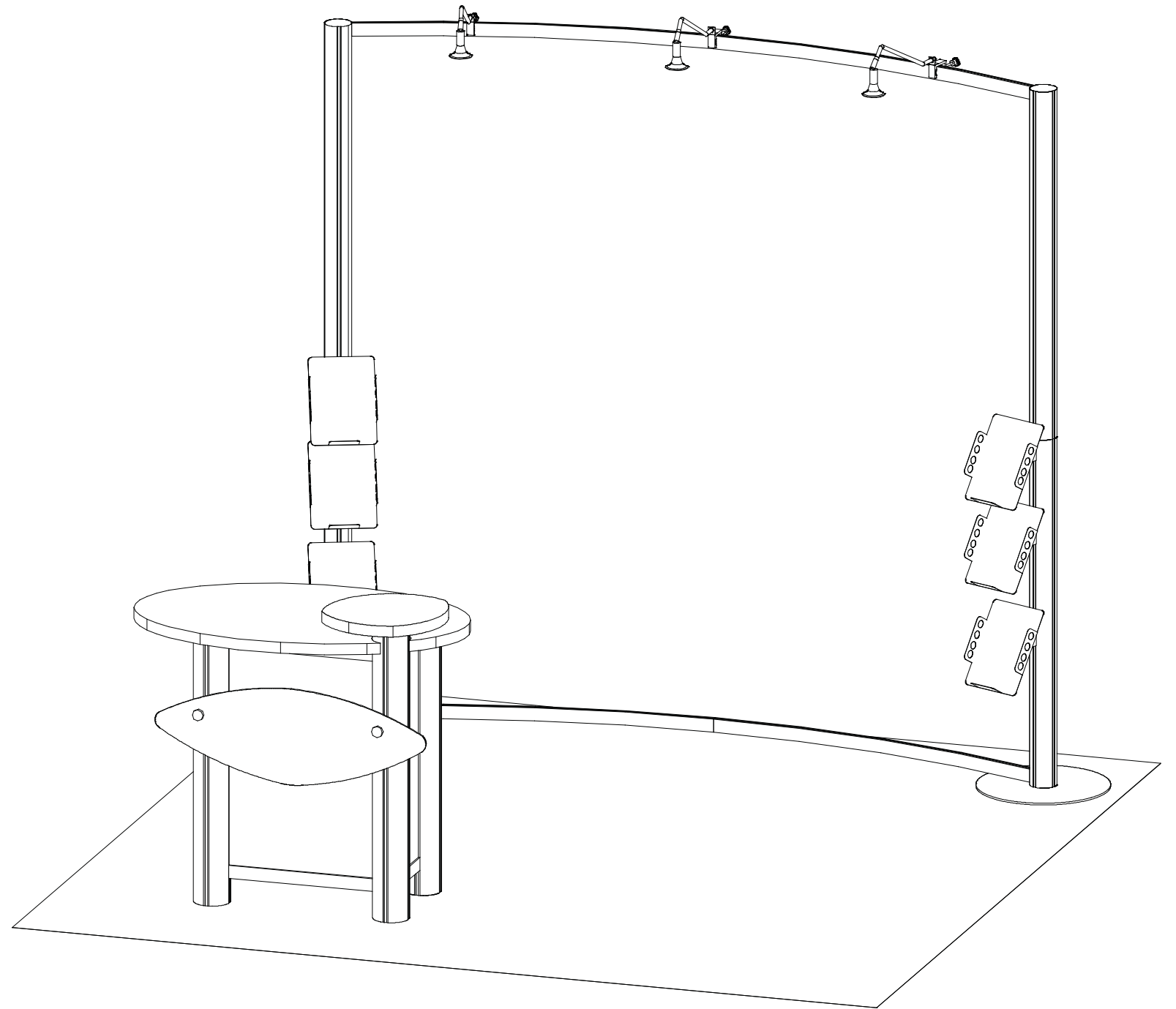

WHEN DISASSEMBLING ALUMINUM EXTRUSION, TIGHTEN ALL SETSCREWS AND LOCKS TO PREVENT LOSS DURING SHIPPING

# visionary™ IDESIGNS

## Using Your Setup Instructions

The Visionary Designs Setup Instructions are created specifically for your configuration. They are laid out sequentially, including an exploded view of the entire display, and then a logical series of detailed steps to assemble the main structure and components. We encourage you to study the instructions **before** attempting to assemble your exhibit.

Each page reminds you to tighten the setscrews after disassembling your exhibit to prevent loss of the locks and setscrews (see below in RED). This is **VERY IMPORTANT**.

## Cleaning and Packing Your Display

- 1) Use care when cleaning aluminum extrusion or acrylic inserts. Use only non-abrasive cleaners.
- 2) When cleaning laminate inserts or countertops, use mild cleansers and a soft material such as cotton.
- 3) Keep all display components away from extreme heat and long exposure to sunlight to avoid warping and fading.
- 4) Retain all packing material. It will make re-packing much easier and will reduce the likelihood of shipping damage.



**The Tool**

Most Visionary Designs exhibits can be assembled with the supplied Hex Key Tool. Occasionally, a flat head screwdriver may be required.



**Typical Connection**

Most horizontal extrusion connections have a patented expandable lock. This lock inserts into the groove of an opposing extrusion. Tightening the lock with the Hex Key Tool expands the lock and creates a strong positive connection.



**Typical Connection (cont'd)**



**Detail B**

**Numbered Label**

Each extrusion contains a numbered label which corresponds with setup instructions. The label is located within a groove of the extrusion (when possible). With Visionary Designs the labels contain Black numbers unless otherwise specified.



**Detail C**

**Horizontal Inline Connection** (remove only one setscrew)

Remove only (1) setscrew when disassembling. Replace setscrew in extrusion after assembling it. Before packing, replace setscrew in extrusion to avoid losing it.

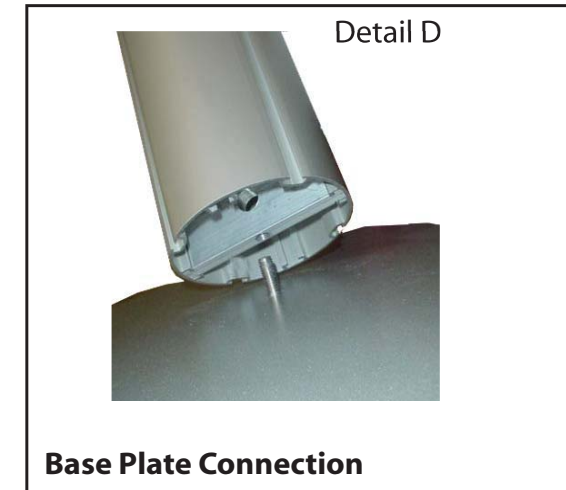

**Detail D**

**Base Plate Connection**

Attach base plate to round or square vertical extrusion using the bolt provided. Be careful not to strip the threads.

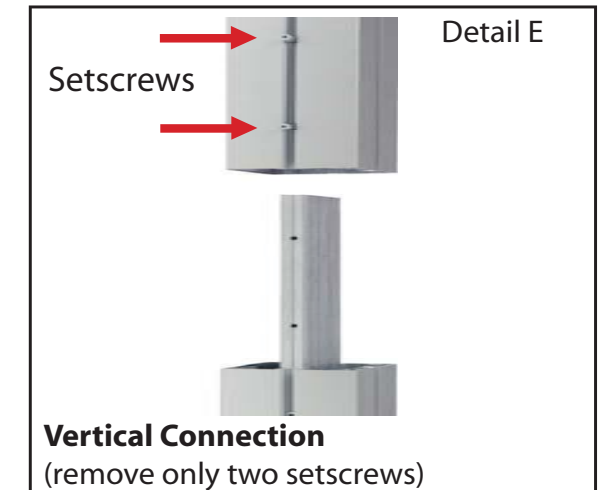

**Detail E**

**Vertical Connection**  
(remove only two setscrews)

When vertical extrusions are packed in portable cases rather than crates or tubs, they must be broken down into smaller sections which then require assembly.

Remove only (2) setscrews when disassembling. Replace setscrews in extrusion after assembling it. Before packing, replace setscrews in extrusion to avoid losing them.

**WHEN DISASSEMBLING ALUMINUM EXTRUSION, TIGHTEN ALL SETSCREWS AND LOCKS TO PREVENT LOSS DURING SHIPPING**

866.652.2100

Item	Qty.	Description
1	2	Base Plate
2	2	48"h Lower Vertical Extrusion
3	2	48"h Upper Vertical Extrusion
4a/4b	1/1	48.56"w Curved Horizontal Extrusion
5a/5b	1/1	48.56"w Curved Horizontal Extrusion

Steps:

- 1) Attach lower vertical extrusions [2] to base plates [1]
- 2) Connect upper vertical extrusions [3] to lower extrusions [2].
- 3) Connect horizontal extrusions together [4a to 4b and 5a to 5b].
- 4) Attach horizontal assemblies [4a/4b and 5a/5b] between vertical extrusions [2/3].
- 5) Apply graphic to assembled backwall.

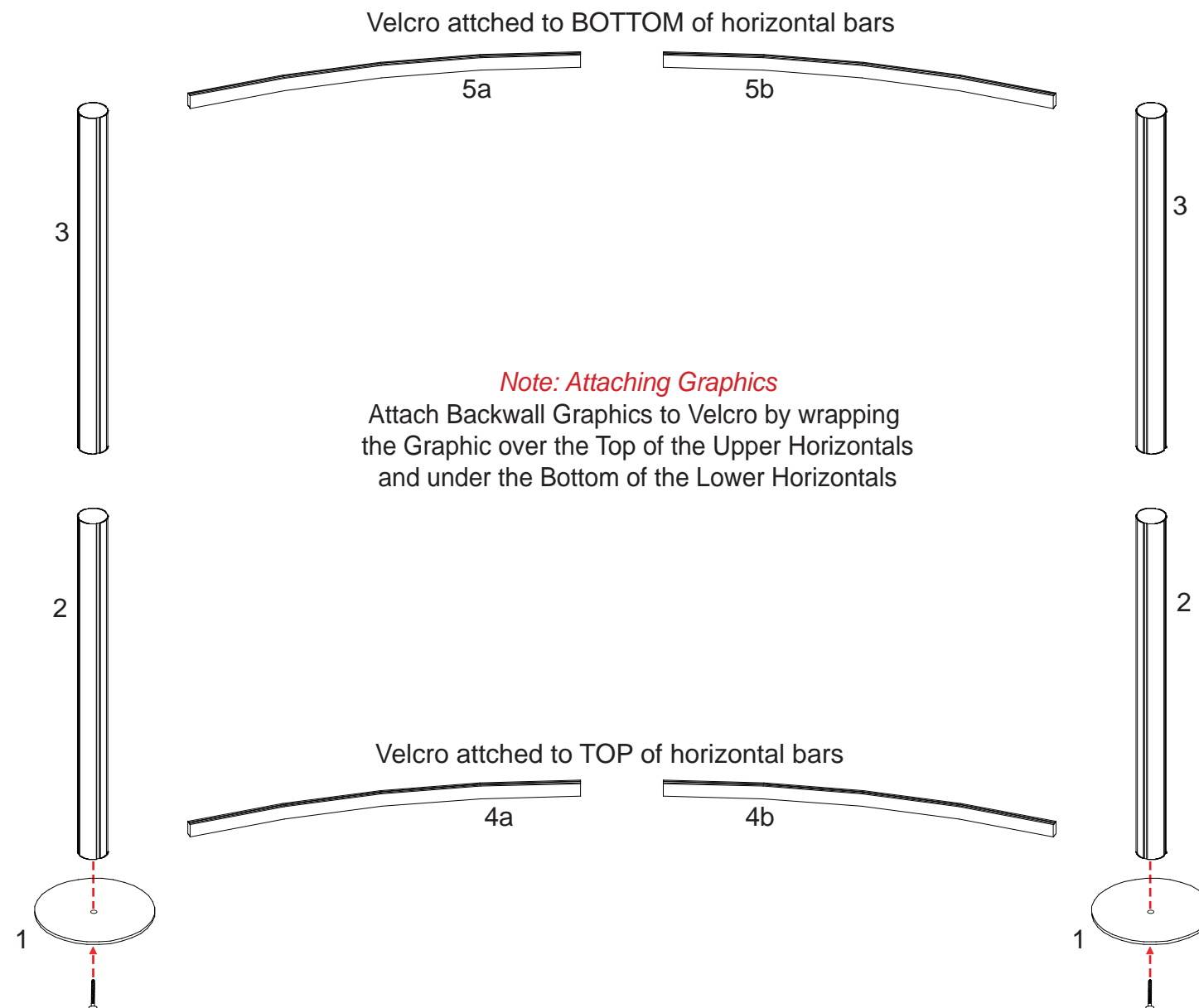
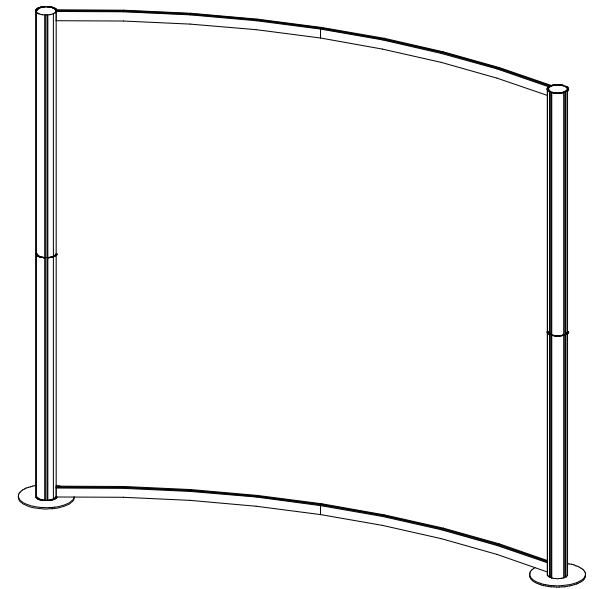

**WHEN DISASSEMBLING ALUMINUM EXTRUSION, TIGHTEN ALL SETSCREWS AND LOCKS TO PREVENT LOSS DURING SHIPPING**

Setups:

- 1) Attach literature racks to vertical extrusions where indicated.
- 2) Attach lights to top of assembled unit.

866.652.2100

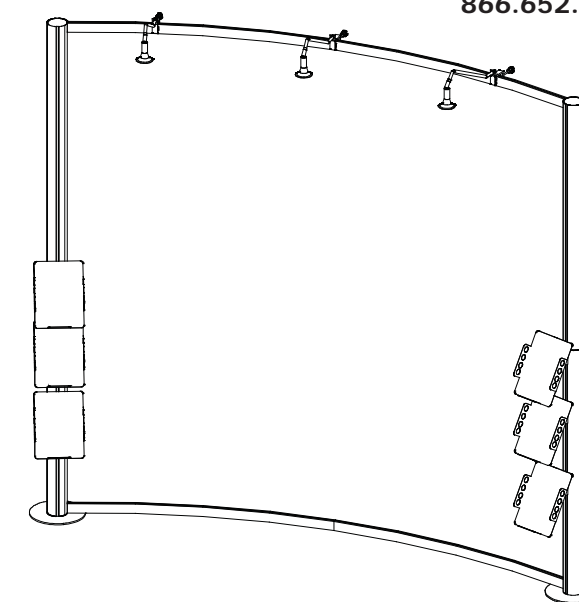
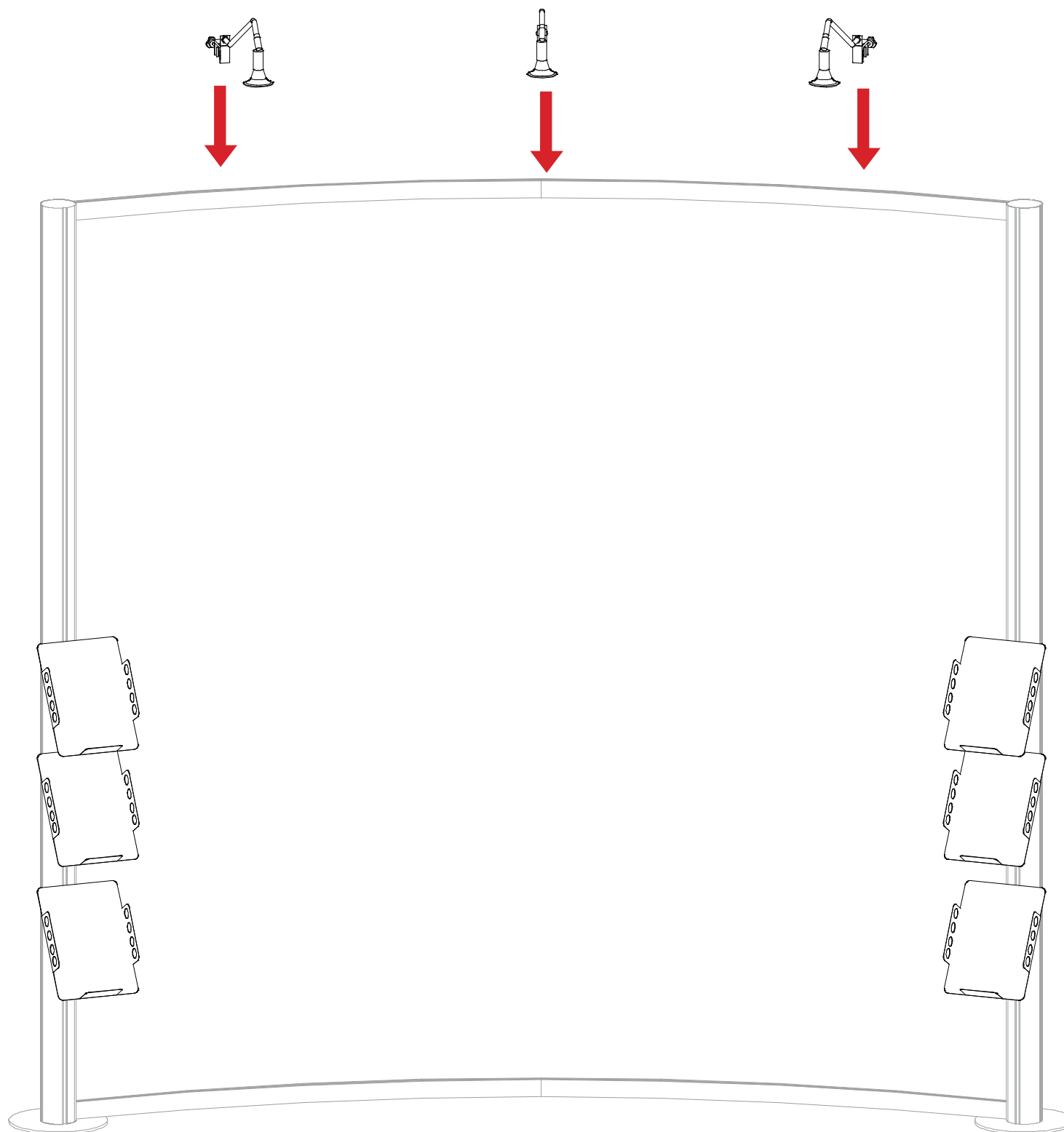
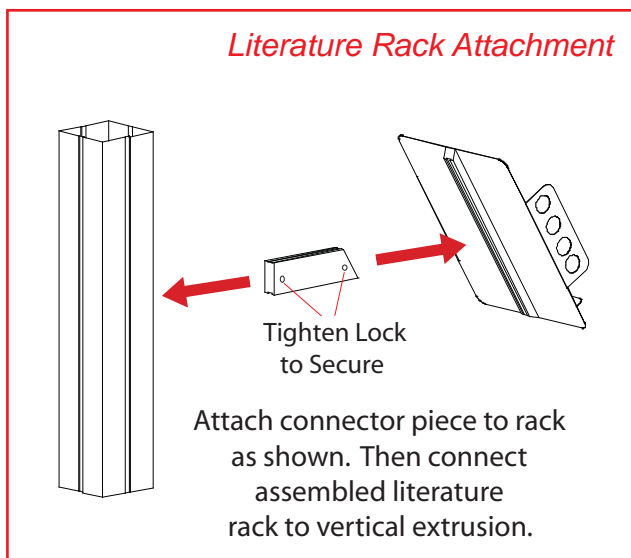
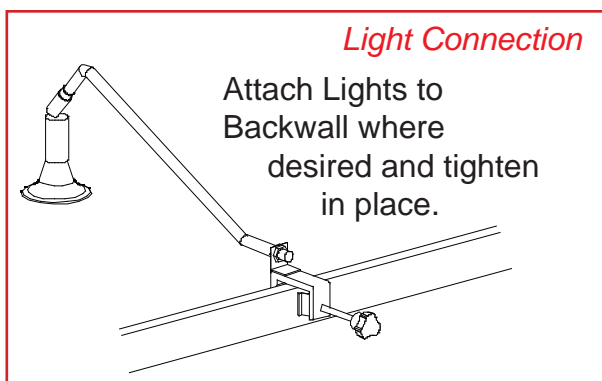

WHEN DISASSEMBLING ALUMINUM EXTRUSION, TIGHTEN ALL SETSCREWS AND LOCKS TO PREVENT LOSS DURING SHIPPING

866.652.2100

Item	Quantity	Description
6	1	38" h Vertical Extrusion
7	1	38" h Vertical Extrusion
8	1	42" h Vertical Extrusion
8a	1	Plate for Counter Connection
9	1	38" h Vertical Extrusion
10	2	20" w Horizontal Extrusion
11	2	8.5" w Horizontal Extrusion
12	2	20" w Horizontal Extrusion
13	2	8.5" w Horizontal Extrusion
	4	Internal Shelf Support

Steps:

- 1) Connect horizontal extrusions [10 and 11] between vertical extrusions [6, 7, 8 and 9] at approximately 3.5" up from floor to bottom of metal.
- 2) Set floor in place atop lip of horizontal extrusions.
- 3) Place doors and inserts in place as shown.
- 4) Connect horizontal extrusions [12 and 13] between vertical extrusions [6, 7, 8 and 9] and atop inserts and door.
- 5) Velcro shelf supports to inside of pedestal, then set internal shelf atop supports.
- 6) Place counter atop assembled pedestal, attach [8A] to extrusion [8] then connect smaller counter to [8A].

**Door Attachment**

Slide pin into hinge attached to Round Vertical. Slide Door hinge atop pin.

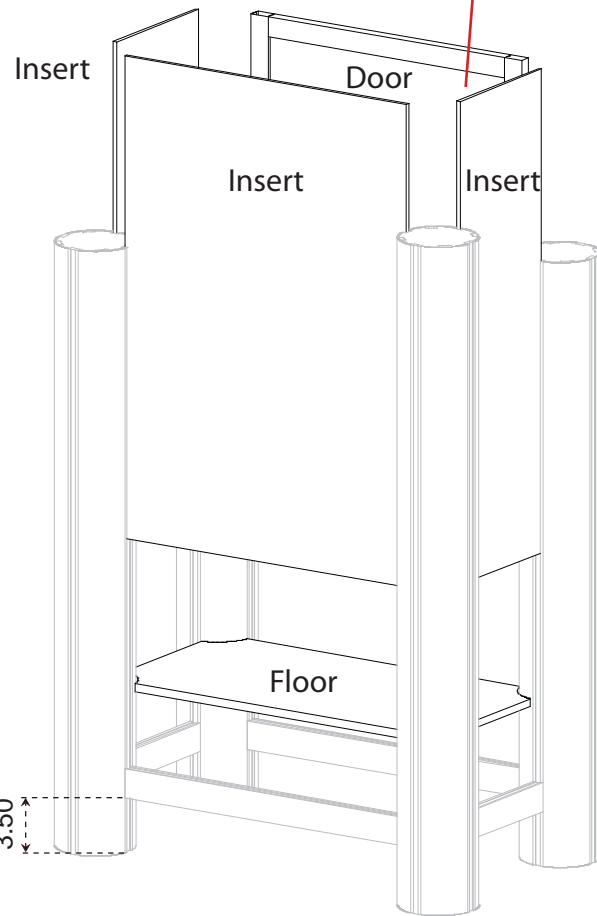
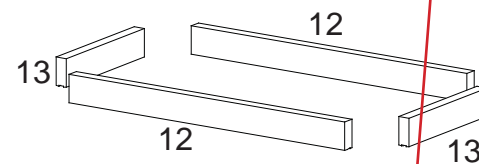
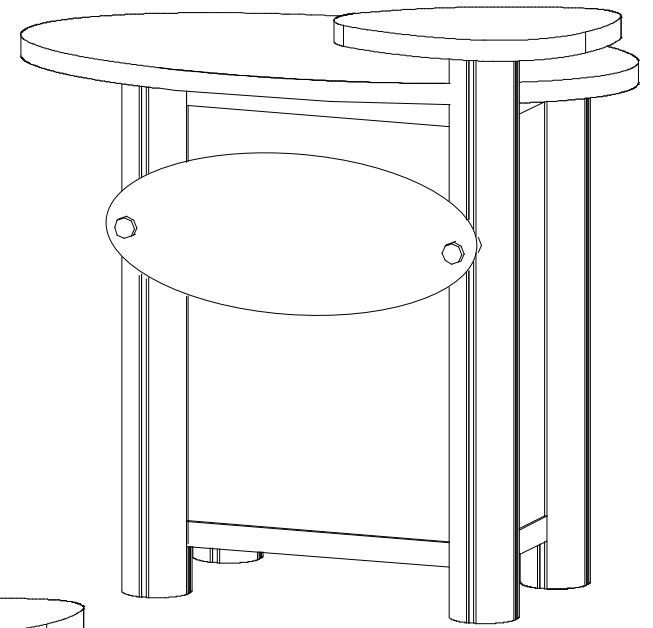
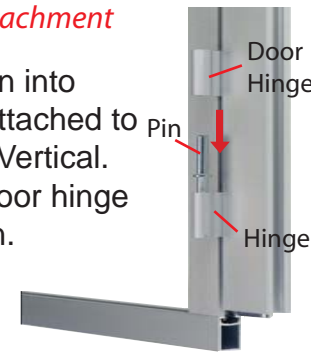

NOTE: TOP SIDE Label needs to be at top of round extrusion.

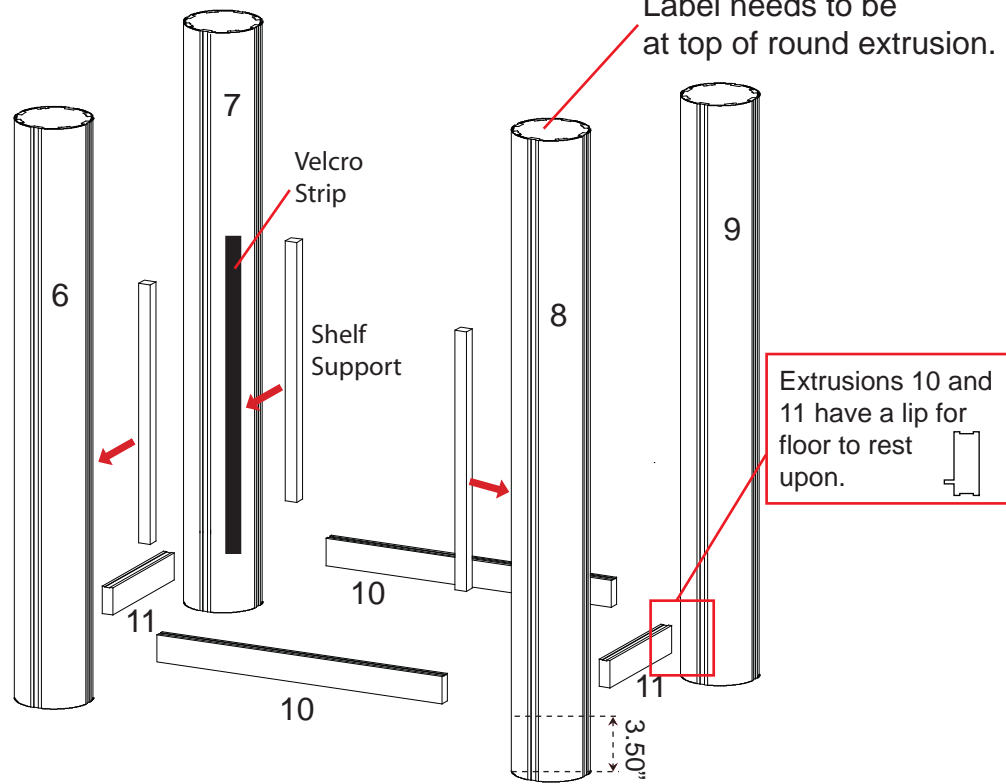

Extrusions 10 and 11 have a lip for floor to rest upon.

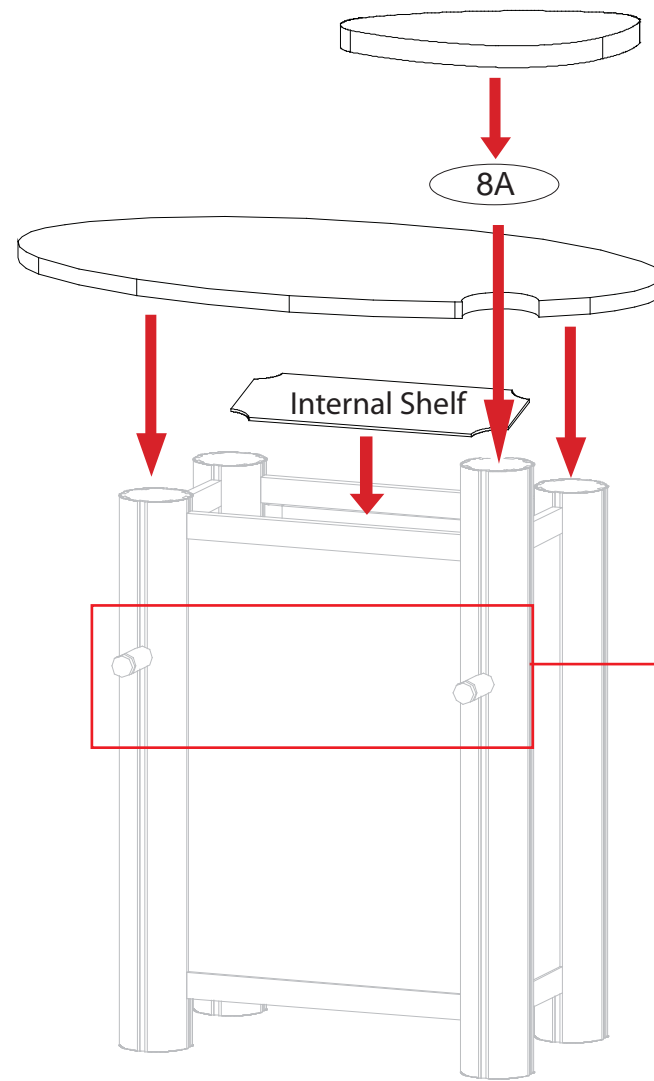

**Plex Graphic Connection**

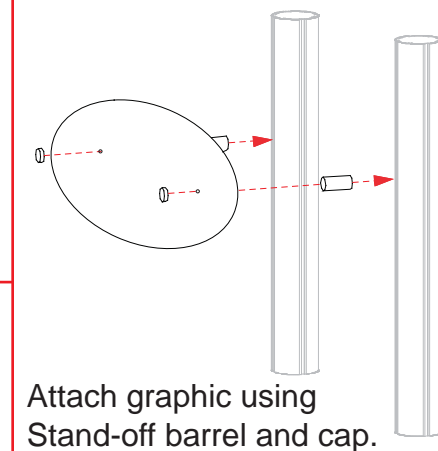

Attach graphic using Stand-off barrel and cap.

**WHEN DISASSEMBLING ALUMINUM EXTRUSION, TIGHTEN ALL SETSCREWS AND LOCKS TO PREVENT LOSS DURING SHIPPING**

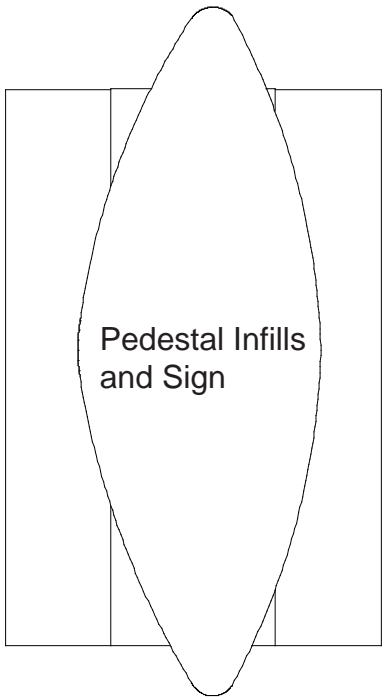

Level 4

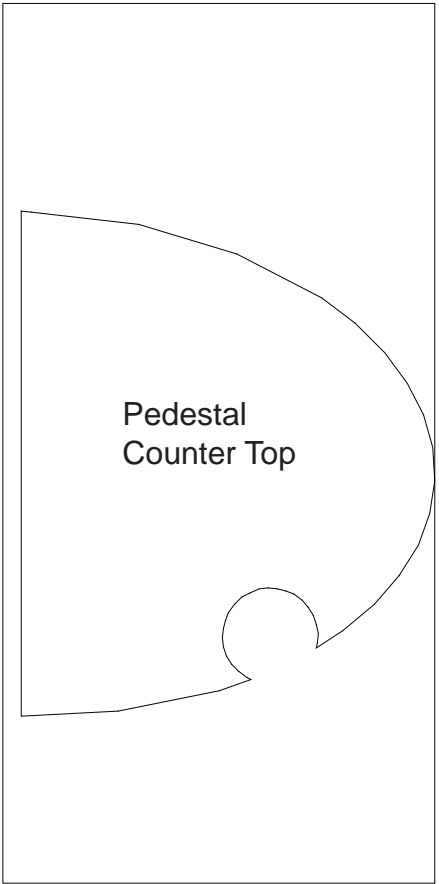

Level 3

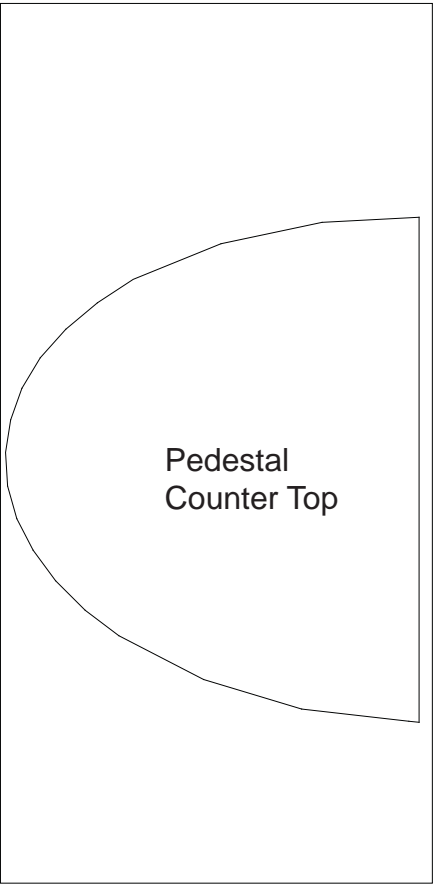

Level 3

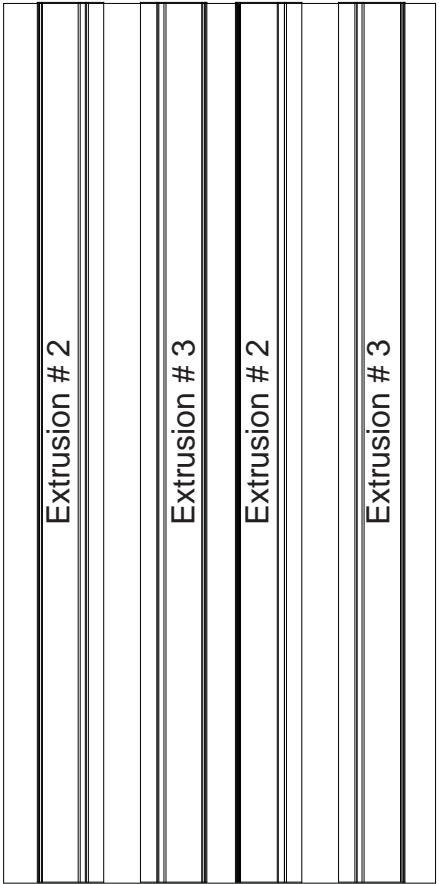

Level 2

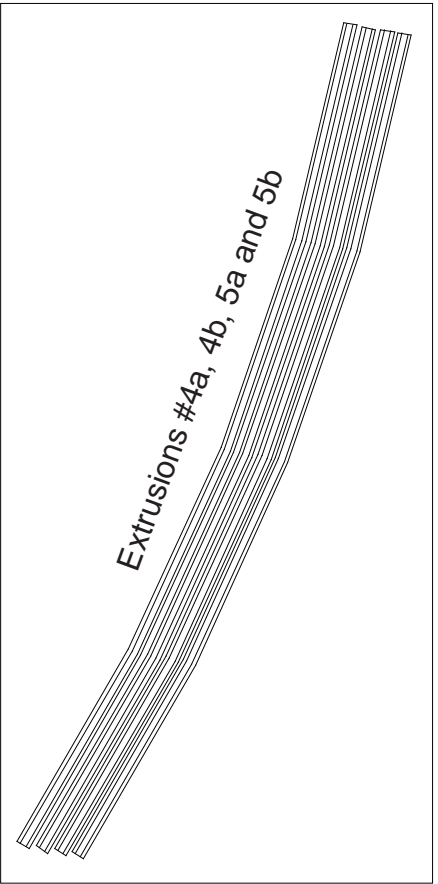

Level 1

WHEN DISASSEMBLING ALUMINUM EXTRUSION, TIGHTEN ALL SETSCREWS AND LOCKS TO PREVENT LOSS DURING SHIPPING

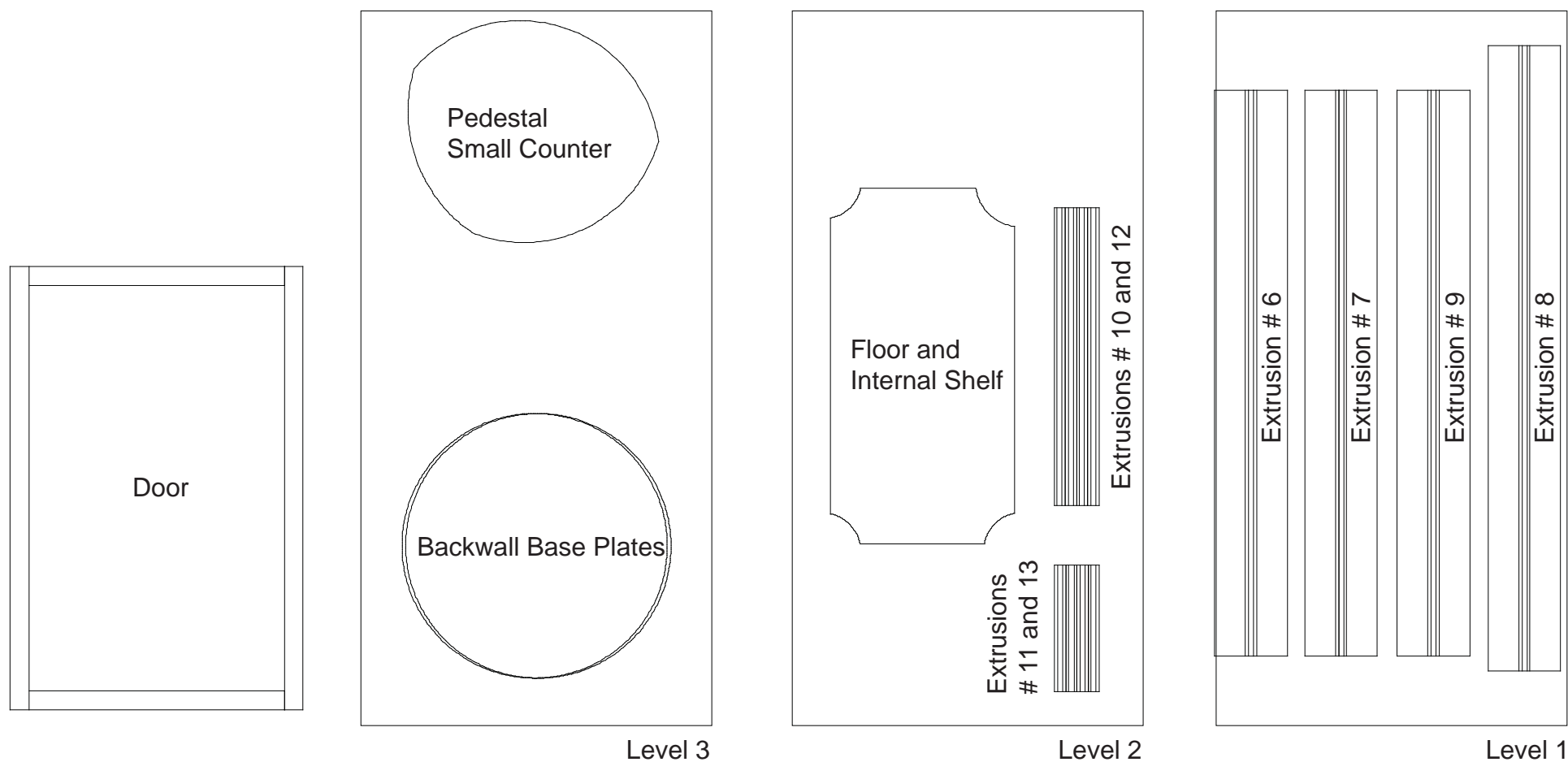

WHEN DISASSEMBLING ALUMINUM EXTRUSION, TIGHTEN ALL SETSCREWS AND LOCKS TO PREVENT LOSS DURING SHIPPING

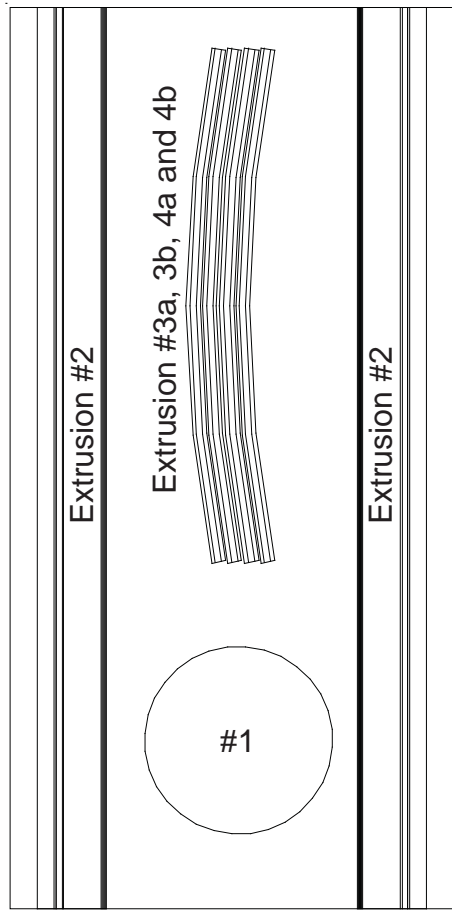

Level 1

- Additional Items:
- Box of Setup Hardware
  - Box of Graphic
  - Box of Literature Racks

WHEN DISASSEMBLING ALUMINUM EXTRUSION, TIGHTEN ALL SETSCREWS AND LOCKS TO PREVENT LOSS DURING SHIPPING