

WHEN DISASSEMBLING ALUMINUM EXTRUSION, TIGHTEN ALL SETSCREWS AND LOCKS TO PREVENT LOSS DURING SHIPPING

visionary™ DESIGNS

Using Your Setup Instructions

The Visionary Designs Setup Instructions are created specifically for your configuration. They are laid out sequentially, including an exploded view of the entire display, and then a logical series of detailed steps to assemble the main structure and components. We encourage you to study the instructions **before** attempting to assemble your exhibit.

Each page reminds you to tighten the setscrews after disassembling your exhibit to prevent loss of the locks and setscrews (see below in RED). This is VERY IMPORTANT.

Cleaning and Packing Your Display

- 1) Use care when cleaning aluminum extrusion or acrylic inserts. Use only non-abrasive cleaners.
- 2) When cleaning laminate inserts or countertops, use mild cleansers and a soft material such as cotton.
- 3) Keep all display components away from extreme heat and long exposure to sunlight to avoid warping and fading.
- 4) Retain all packing material. It will make re-packing much easier and will reduce the likelihood of shipping damage.



The Tool

Most Visionary Designs exhibits can be assembled with the supplied Hex Key Tool. Occasionally, a flat head screwdriver may be required.



Typical Connection

Most horizontal extrusion connections have a patented expandable lock. This lock inserts into the groove of an opposing extrusion. Tightening the lock with the Hex Key Tool expands the lock and creates a strong positive connection.



Typical Connection (cont'd)

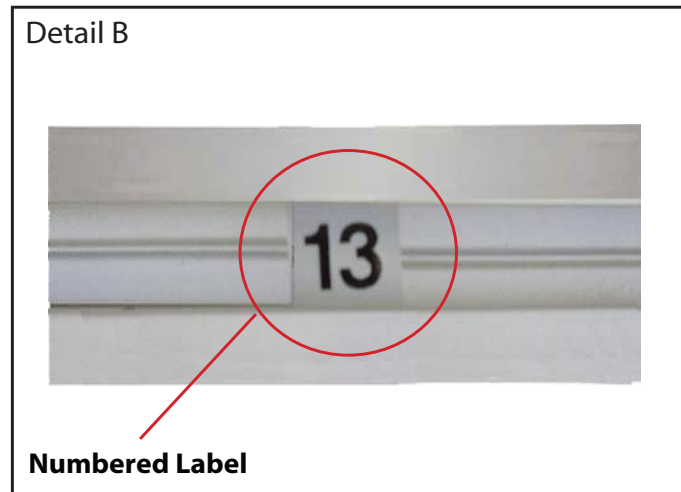

Numbered Label

Each extrusion contains a numbered label which corresponds with setup instructions. The label is located within a groove of the extrusion (when possible). With Visionary Designs the labels contain Black numbers unless otherwise specified.



Horizontal Inline Connection (remove only one setscrew)

Remove only (1) setscrew when disassembling. Replace setscrew in extrusion after assembling it. Before packing, replace setscrew in extrusion to avoid losing it.

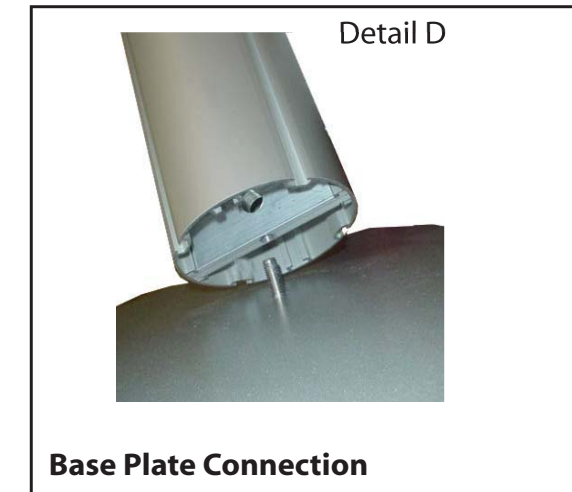

Base Plate Connection

Attach base plate to round or square vertical extrusion using the bolt provided. Be careful not to strip the threads.

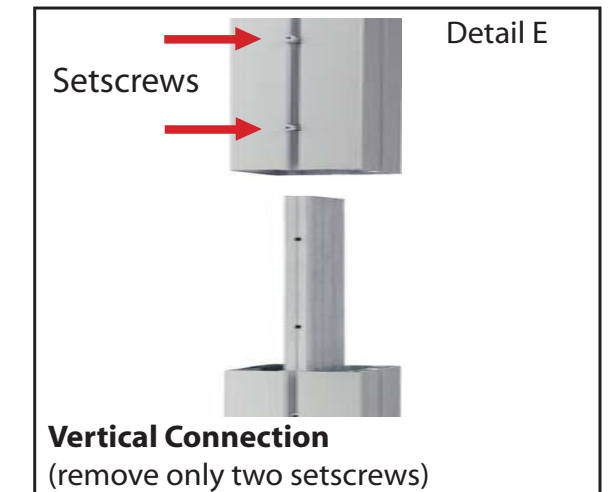

Vertical Connection

(remove only two setscrews)

When vertical extrusions are packed in portable cases rather than crates or tubs, they must be broken down into smaller sections which then require assembly.

Remove only (2) setscrews when disassembling. Replace setscrews in extrusion after assembling it. Before packing, replace setscrews in extrusion to avoid losing them.

WHEN DISASSEMBLING ALUMINUM EXTRUSION, TIGHTEN ALL SETSCREWS AND LOCKS TO PREVENT LOSS DURING SHIPPING

Item	Qty.	Description
1	2	Square Base Plate
2	1	66"h Lower Vertical Extrusion
3	1	66"h Upper Vertical Extrusion
4	1	90"h Lower Vertical Extrusion w/ Flexible Connector Attached
5	1	84"h Upper Vertical Extrusion
6	1	42"h Vertical Extrusion
7	1	42"h Vertical Extrusion
8	1	78"w Horizontal Extrusion w/ Velcro Attached
9	1	78"w Horizontal Extrusion
10	4	37.87"w Curved Horizontal Extrusion

Steps:

- 1) Attach lower vertical extrusions [2 and 4] to base plates [1].
- 2) Connect upper vertical extrusions to lower extrusions [3 to 2 and 5 to 4].
- 3) Attach horizontal extrusions [8 and 9] between vertical assemblies [2/3 and 4/5] where indicated.
- 4) Attach curved horizontal extrusions [10] between vertical extrusions [4/5, 6 and 7] where indicated.
- 5) Apply graphic to assembled frame, see Graphic Attachment.

Note: Attaching Graphics
Velcro Backwall Graphics to Front of Lower Bar and Fold over Upper Bar, then Velcro the other End to Back of Lower Bar

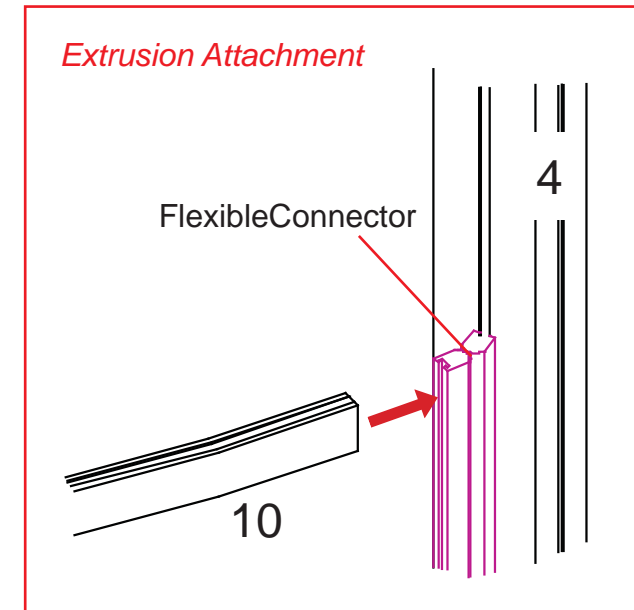
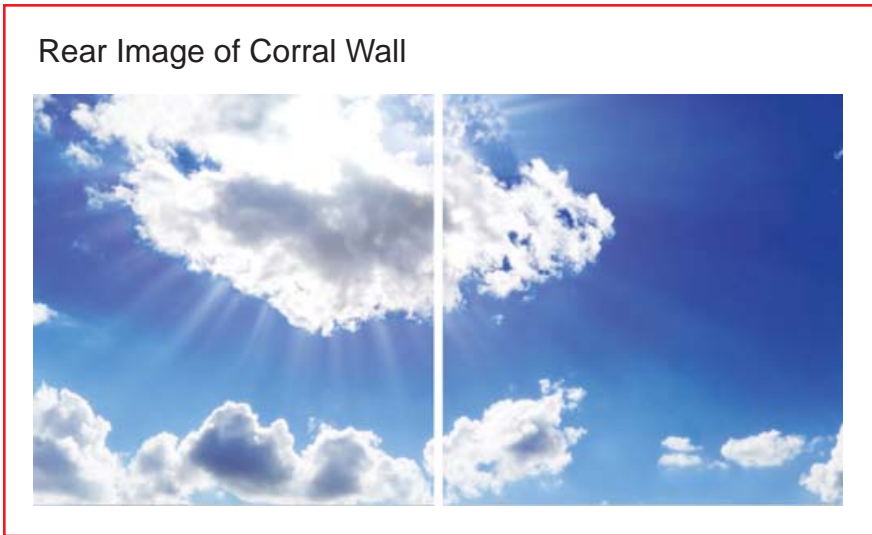
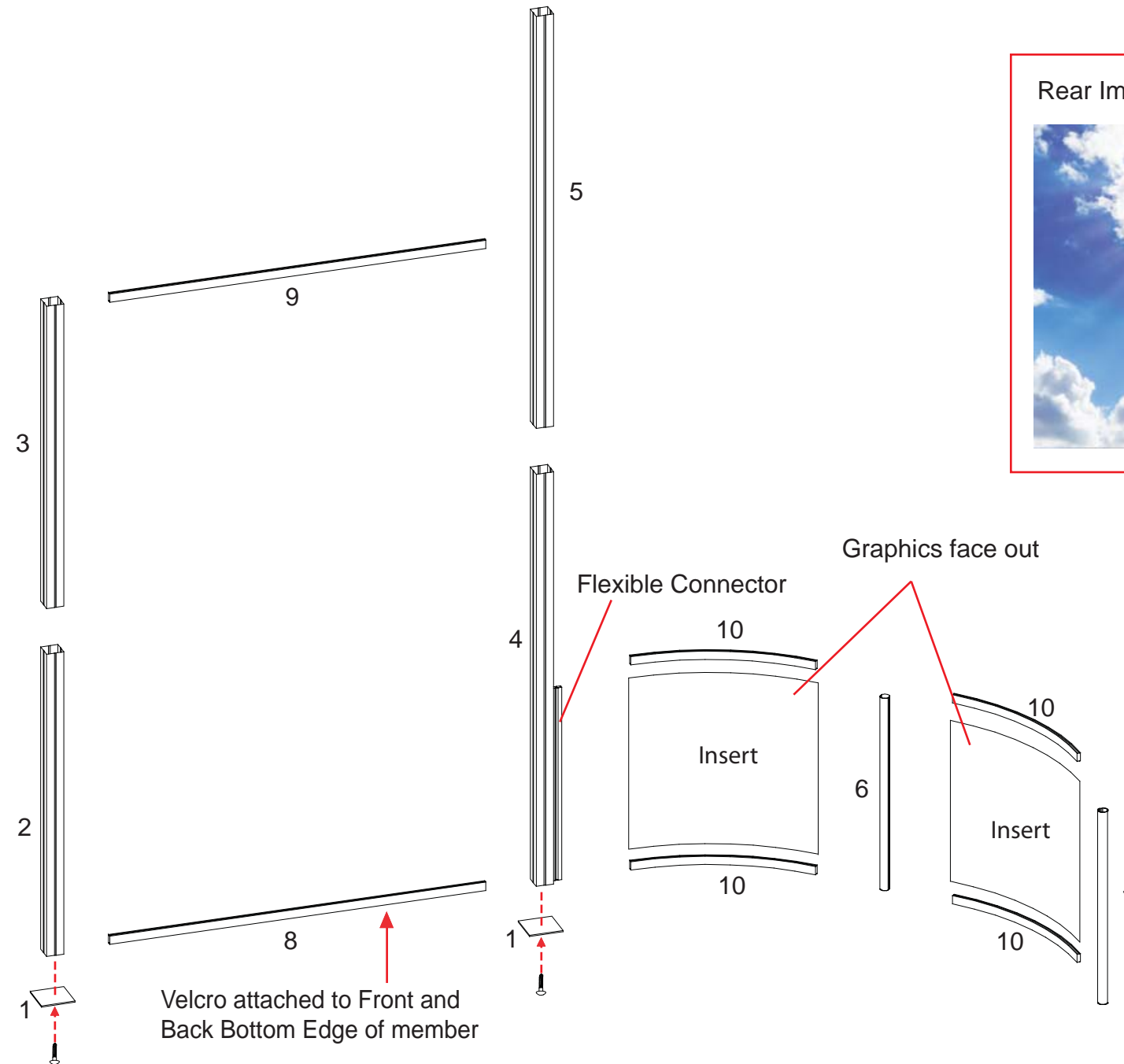
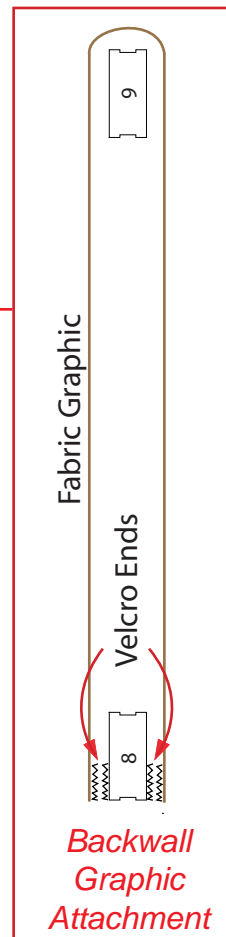

WHEN DISASSEMBLING ALUMINUM EXTRUSION, TIGHTEN ALL SETSCREWS AND LOCKS TO PREVENT LOSS DURING SHIPPING

Item	Qty.	Description
11	1	66"h Lower Vertical Extrusion
12	1	66"h Upper Vertical Extrusion
13	1	78"w Horizontal Extrusion w/ Velcro Attached
14	1	78"w Horizontal Extrusion

Steps:

- 1) Attach lower vertical extrusion [11] to round table.
- 2) Connect upper vertical extrusions to lower extrusions [12 to 11].
- 3) Attach horizontal extrusions [13 and 14] between vertical assemblies [4/5 and 11/12] where indicated.
- 4) Apply graphic to assembled frame, see Graphic Attachment.

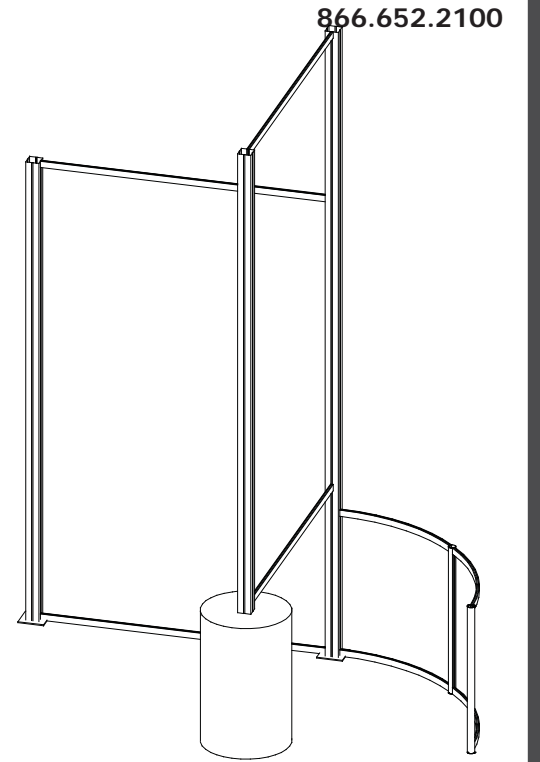

866.652.2100

Note: Attaching Graphics
Velcro Backwall Graphics to Front of Lower Bar and Fold over Upper Bar, then Velcro the other End to Back of Lower Bar.

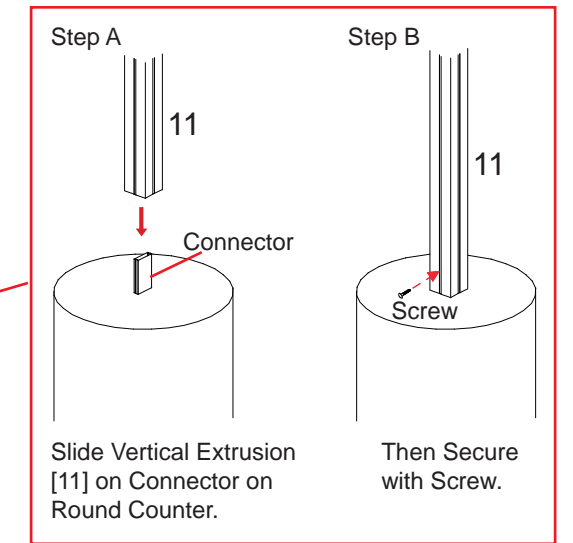
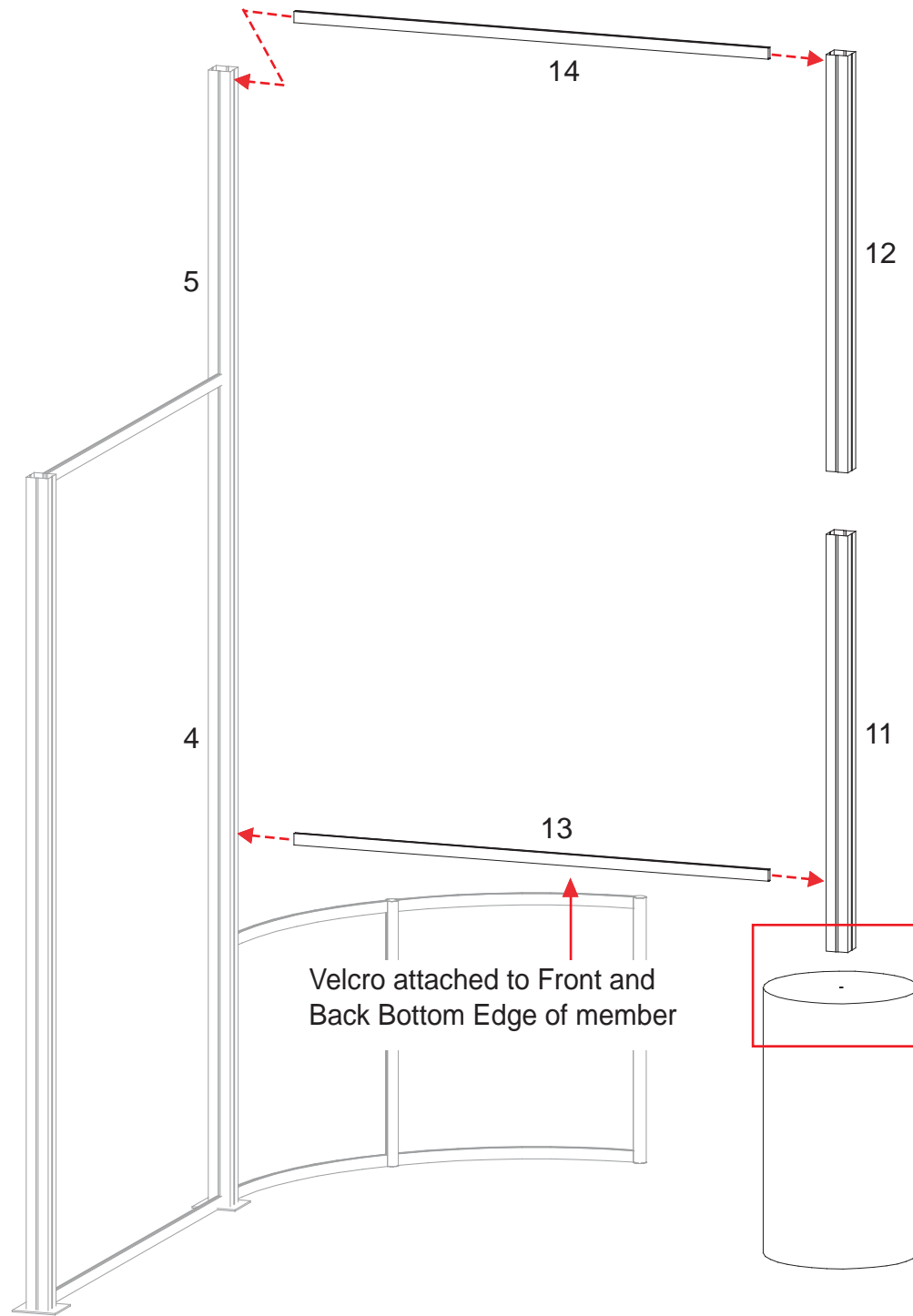

WHEN DISASSEMBLING ALUMINUM EXTRUSION, TIGHTEN ALL SETSCREWS AND LOCKS TO PREVENT LOSS DURING SHIPPING

Item	Qty.	Description
15	1	96" Vertical Extrusion w/ Door Stop Attached
16	1	96" 3-way Connector Extrusion
17	1	96" Vertical Extrusion w/ Connector Attached
18	1	96" Vertical Extrusion w/ Door Hinges Attached
19	7	21.2" Horizontal Extrusion
20	2	21.2" Horizontal Extrusion for Counter Attachment

Steps:

- 1) Attach horizontal extrusions [19 and 20] between vertical extrusions [15, 16, 17 and 18].
- 2) Place inserts where indicated.

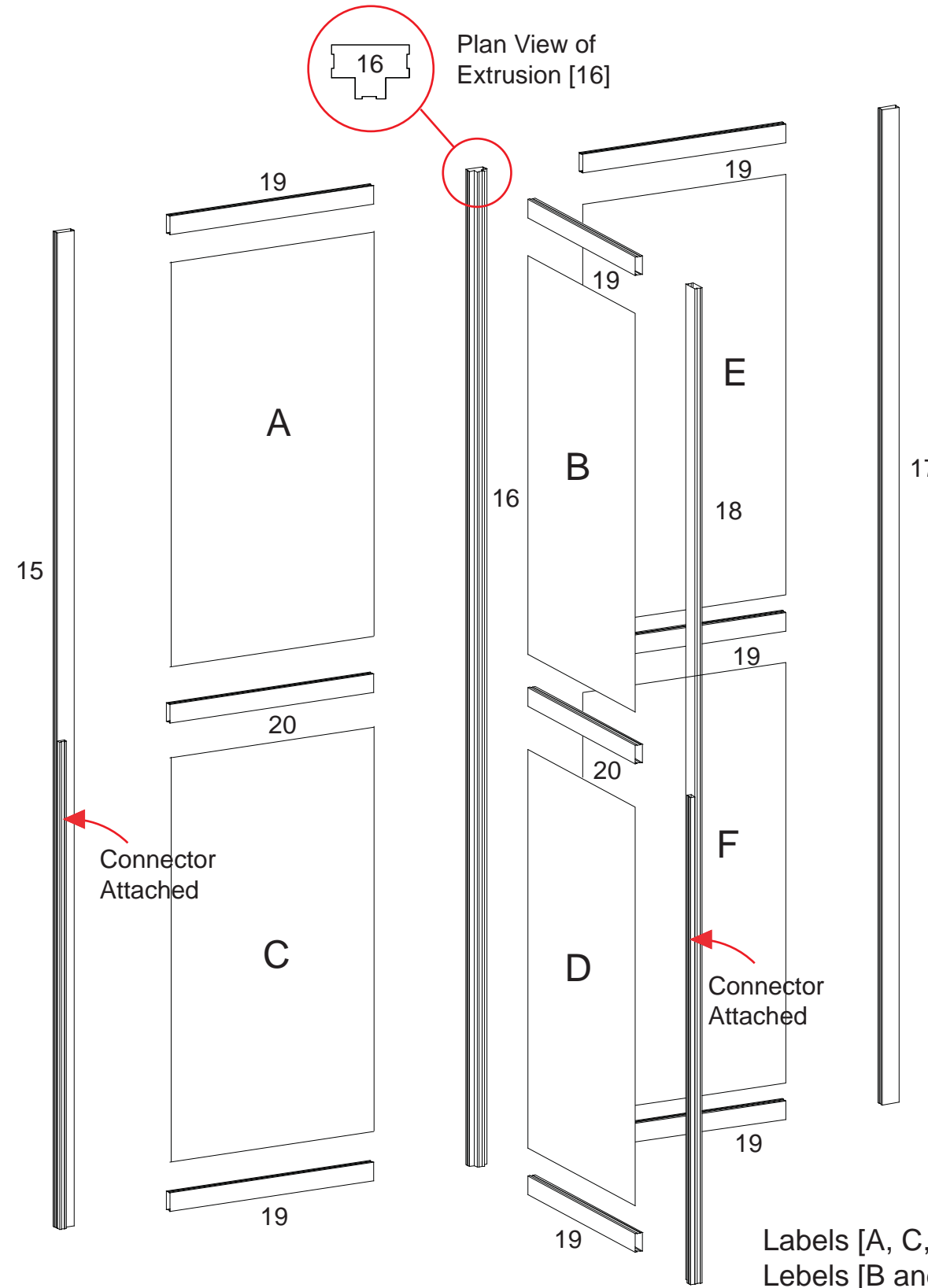

QTY. 2

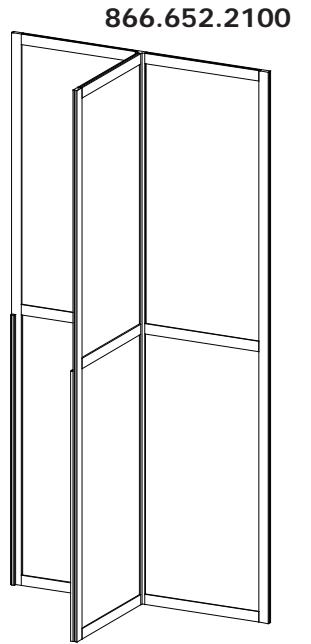
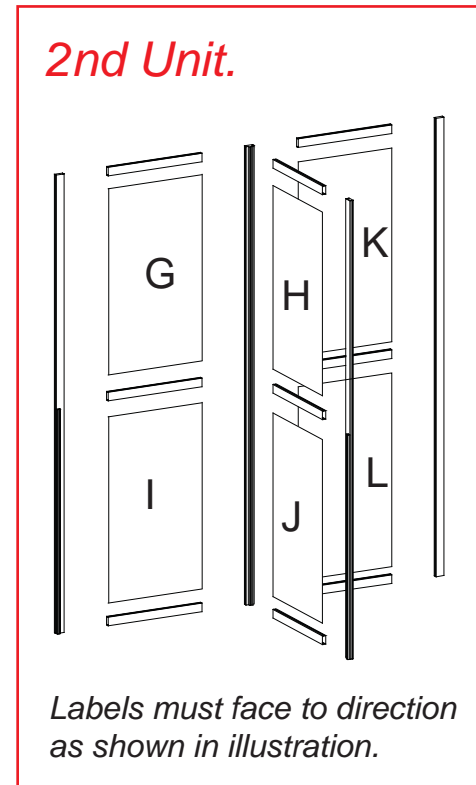

WHEN DISASSEMBLING ALUMINUM EXTRUSION, TIGHTEN ALL SETSCREWS AND LOCKS TO PREVENT LOSS DURING SHIPPING

Item	Qty.	Description
21	2	36.24"w Curved Horizontal Extrusion

- Steps:
- 1) Attach curved horizontal bars [21] between vertical extrusions [15 and 18], placing door where indicated.
 - 2) Attach thumbscrew to inner corner of extrusion where indicated.
 - 3) Place counter top on assembled base and thumbscrew.

866.652.2100

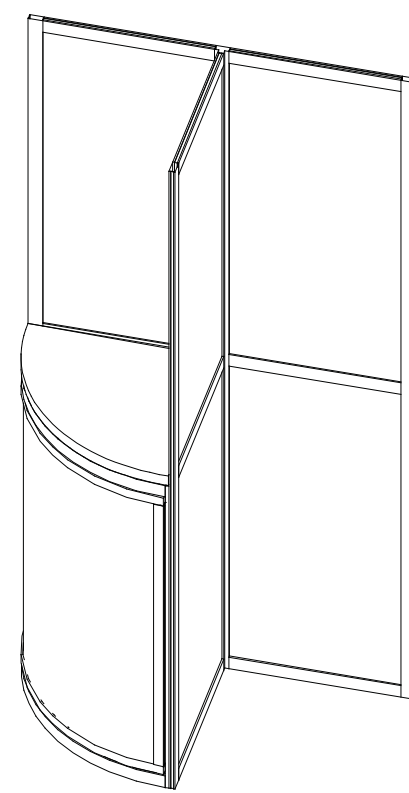
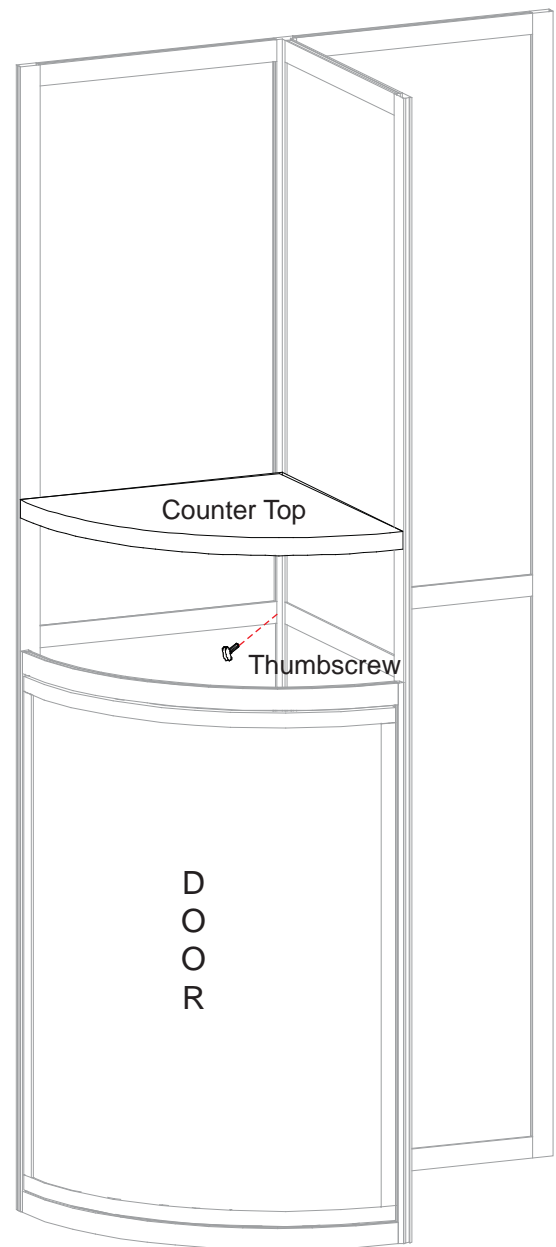
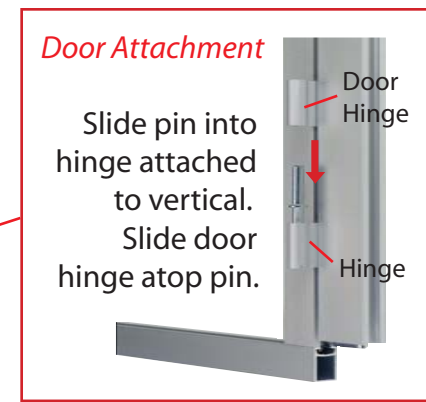
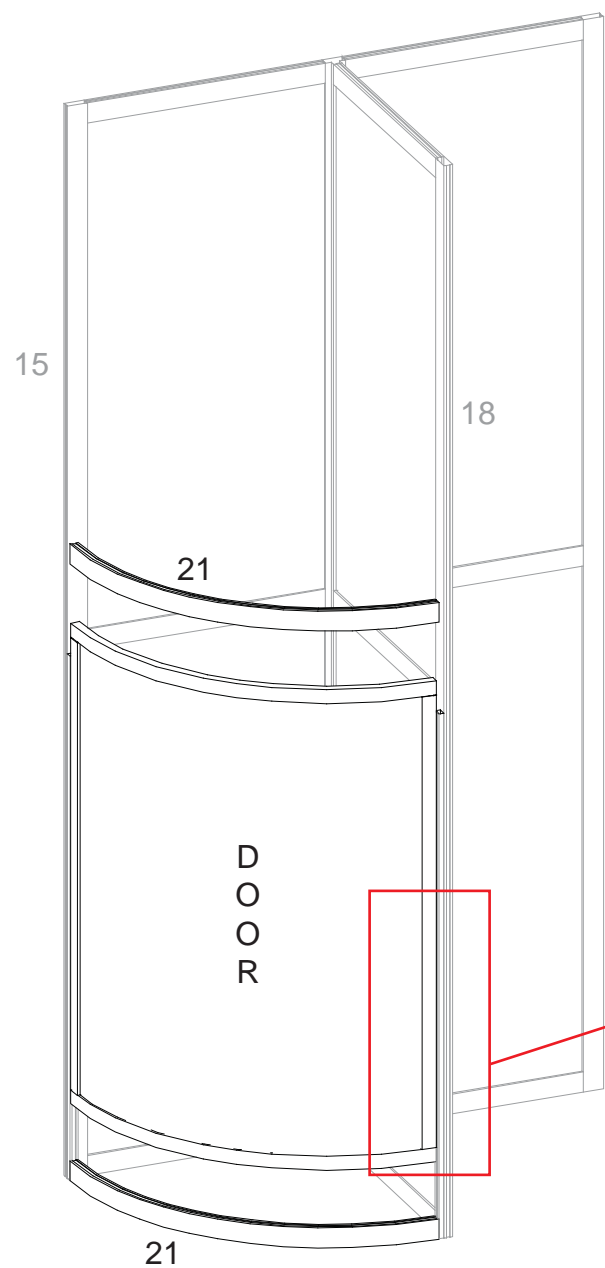

QTY. 2

WHEN DISASSEMBLING ALUMINUM EXTRUSION, TIGHTEN ALL SETSCREWS AND LOCKS TO PREVENT LOSS DURING SHIPPING

866.652.2100

Item	Qty.	Description
22	1	72" h Round Vertical Extrusion
23	1	72" h Round Vertical Extrusion
24	1	42" h 90° Corner Extrusion w/ Door Stop Attached
25	1	42" h 90° Corner Extrusion w/ Door Hinges Attached
26	4	10" w Horizontal Extrusion
27	2	24" w Horizontal Extrusion
27A	2	22.25" w Horizontal Extrusion

Steps:

- 1) Attach lower horizontal bars [26, 27 and 27A] between vertical extrusions [22, 23, 24 and 25].
- 2) Place inserts and attach door where indicated.
- 3) Attach upper horizontal bars [26, 27 and 27A] between vertical extrusions [22, 23, 24 and 25].
- 4) Set counter top on assembled base.
- 5) Attach monitor mount to assembled workstation as shown.

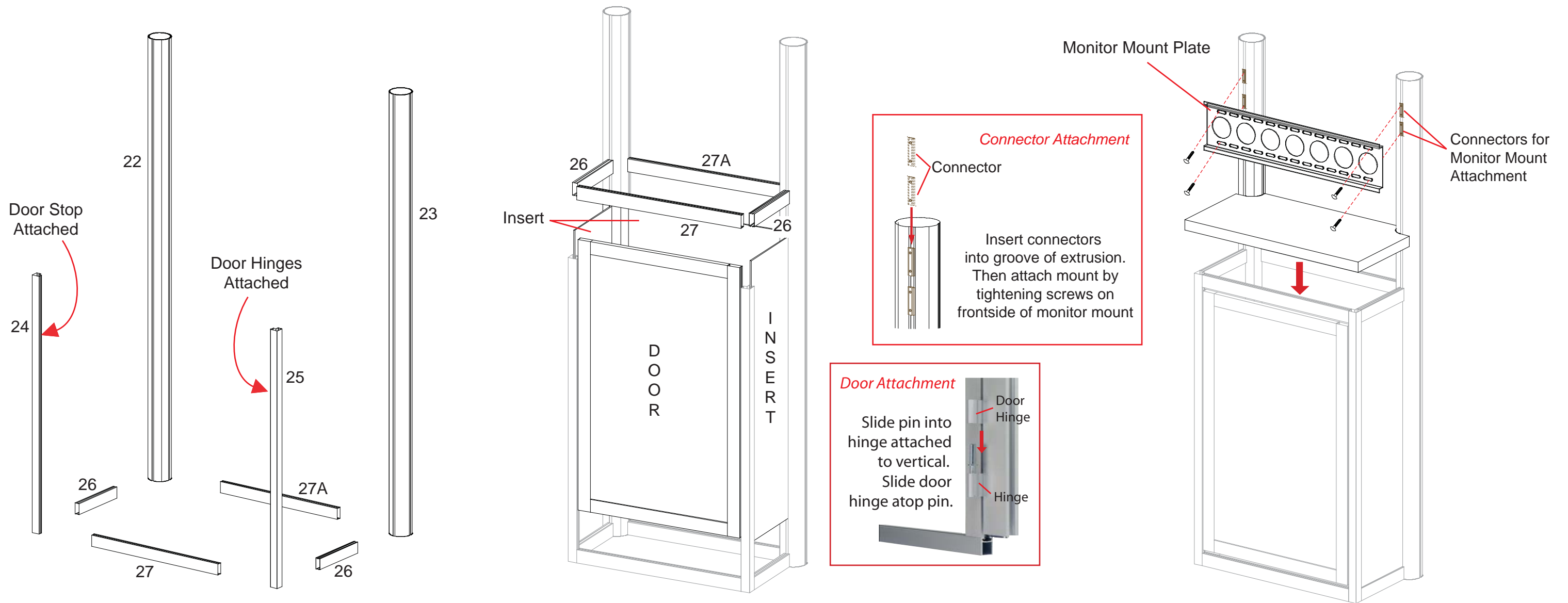

WHEN DISASSEMBLING ALUMINUM EXTRUSION, TIGHTEN ALL SETSCREWS AND LOCKS TO PREVENT LOSS DURING SHIPPING

Item	Qty.	Description
28	1	Base Plate
29	1	41.25"h Vertical Extrusion

866.652.2100

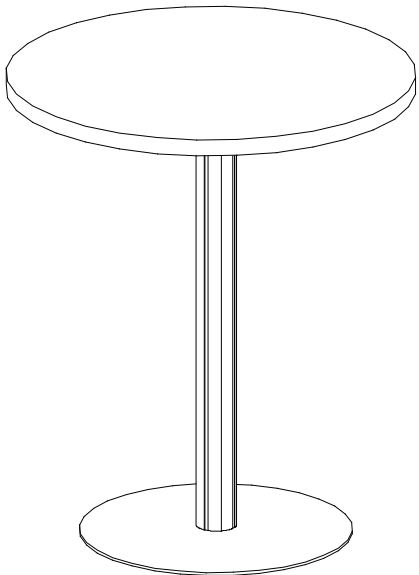

Steps:

- 1) Attach horizontal extrusion [29] to base plate [28].
- 2) Attach counter top to assembled base.

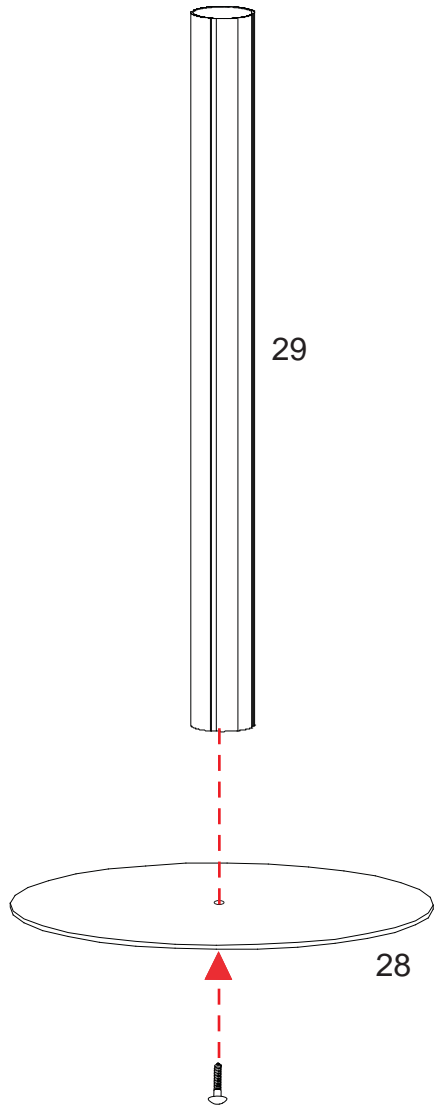
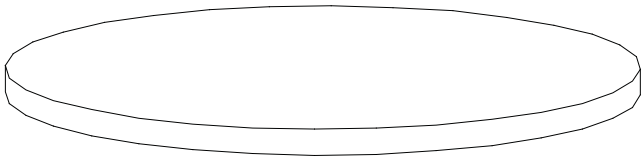

WHEN DISASSEMBLING ALUMINUM EXTRUSION, TIGHTEN ALL SETSCREWS AND LOCKS TO PREVENT LOSS DURING SHIPPING

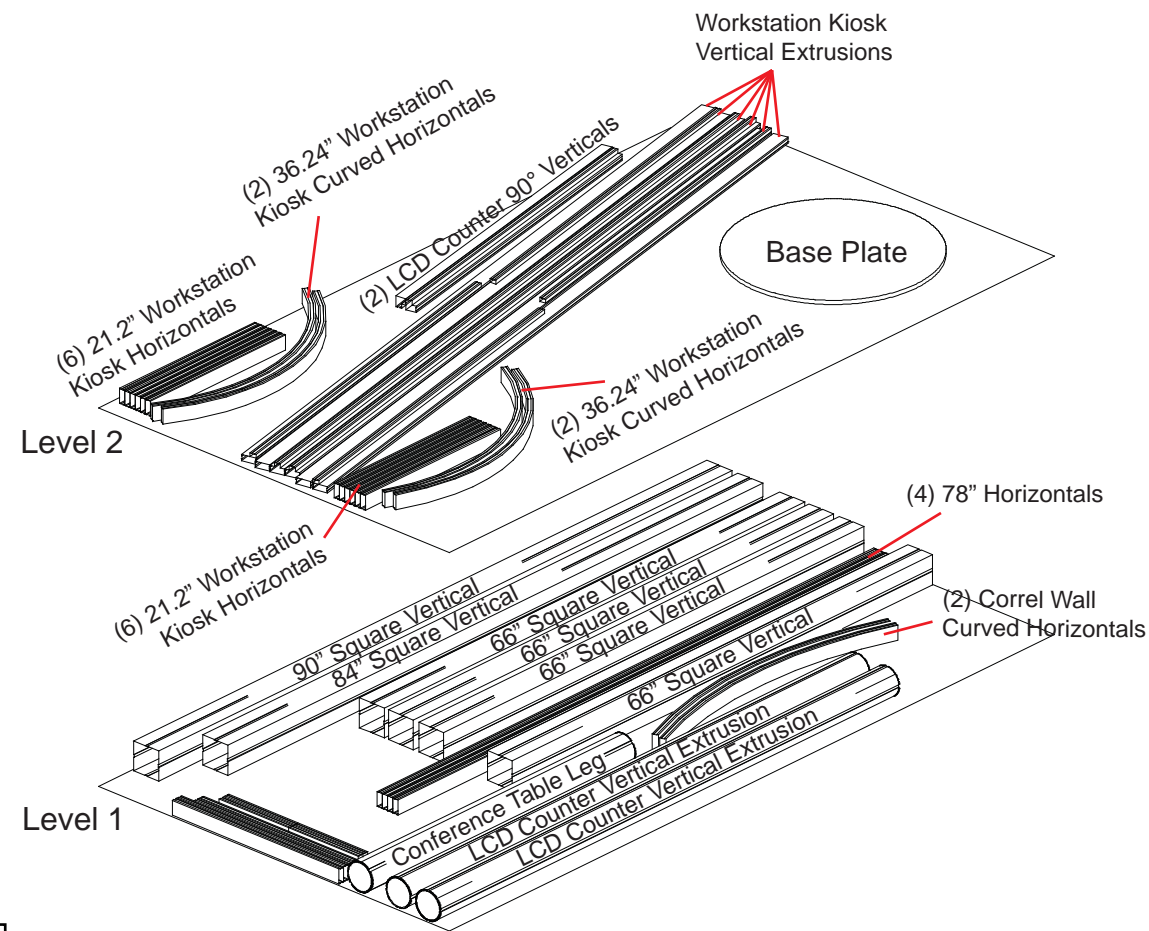

Workstation Kiosk Doors and Assembled Correl Wall Section

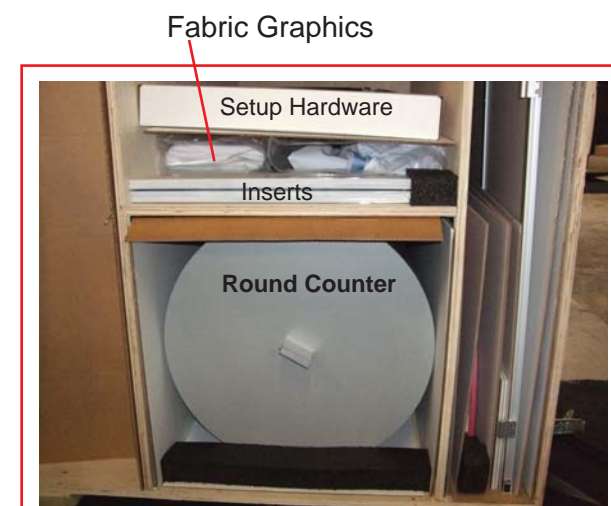
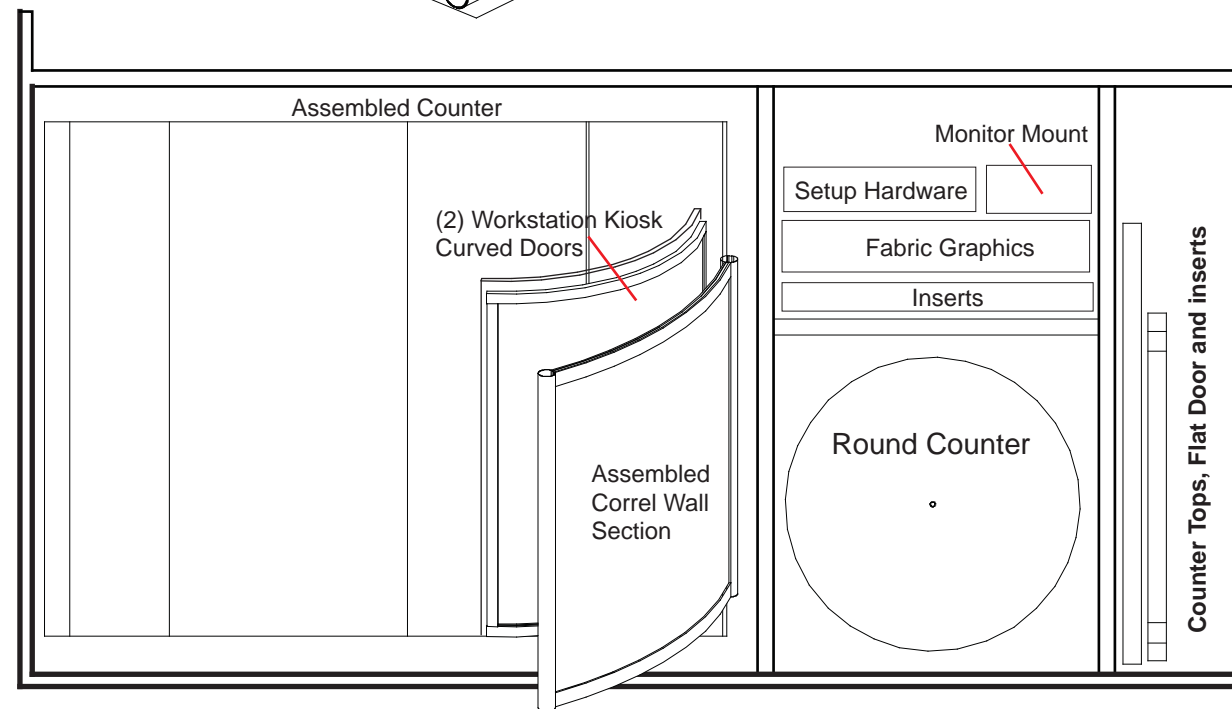

WHEN DISASSEMBLING ALUMINUM EXTRUSION, TIGHTEN ALL SETSCREWS AND LOCKS TO PREVENT LOSS DURING SHIPPING