

euro It

Example of Light Box Assembly

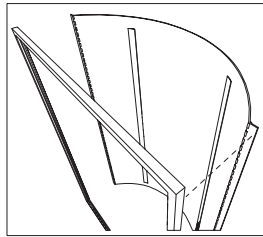

Step 1: Making sure that velcro is facing to the front of the booth bend reflector and attach hinged portion to velcro attached to back of light box frame.

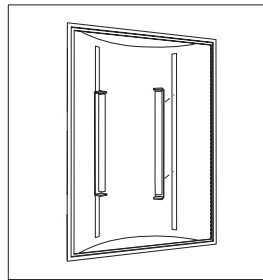

Step 2: Place light bars on velcro strips. Please note as every graphic is different some position adjustment may need to be made for optimum results.

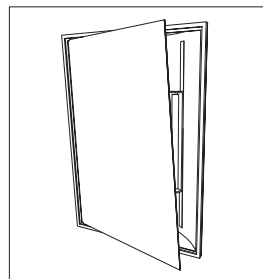

Step 3: Using magnetic tape place graphic onto inside flange of frame.

| Item Number | Description |
|-------------|---|
| 1 | 11.5"w x 42"h Flat Panel |
| 2 | 11.5"r x 42"h Quarter Curve Panel |
| 3 | 11.5"r x 42"h Quarter Curve Light Box Frame |
| 4 | 11.5"w x 42"h Flat Panel |
| 5 | 42"h T Connector |
| 6 | 19"w x 38"h Flat Panel |
| 7 | 11.5"r x 38"h Quarter Curve Panel |
| 8 | 11.5"r x 38"h Quarter Curve Panel |
| 9 | 19"w x 38"h Door Panel |
| 10 | 42"h T Connector |
| 11 | 23"w x 4" Flat Panel |

Steps:

1) Assemble by starting at panel #1 and continue in numerical order.

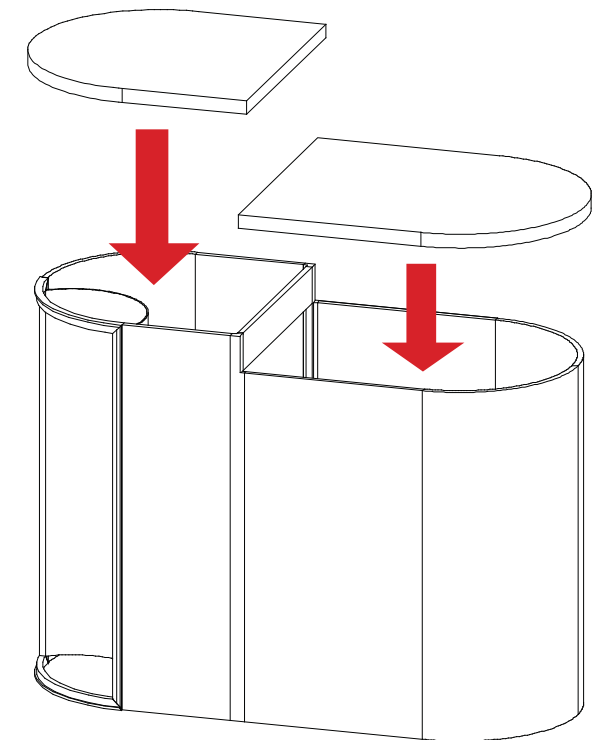
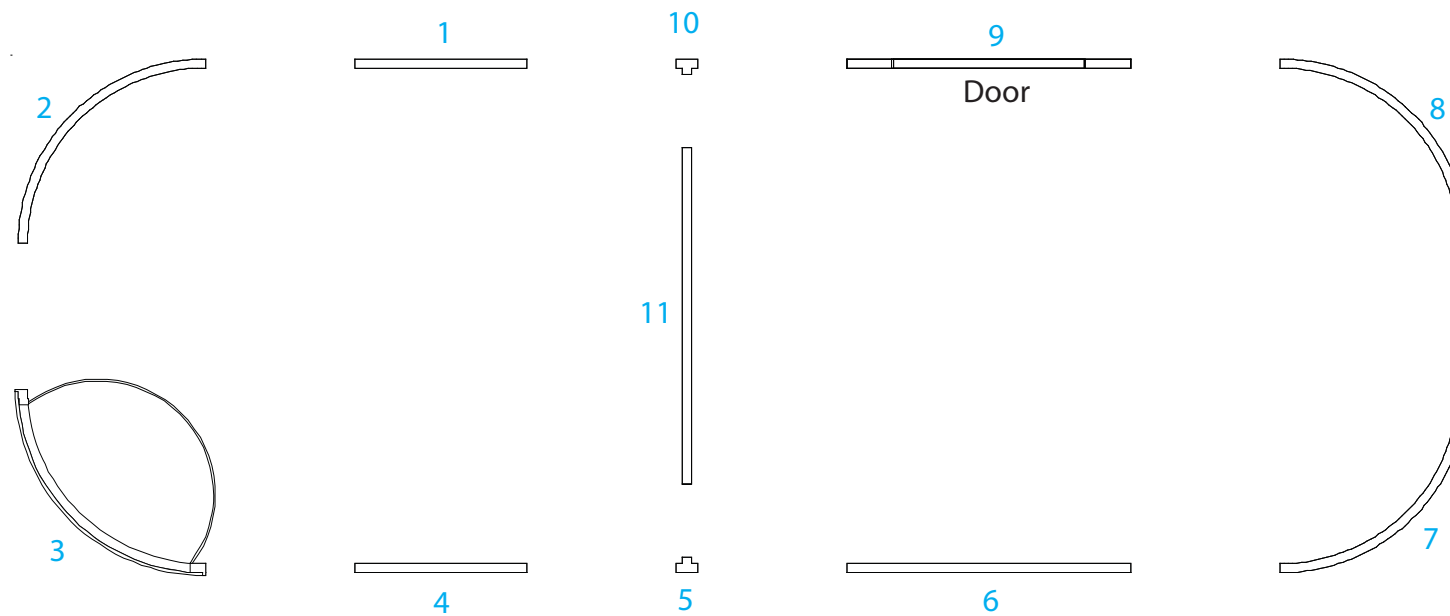
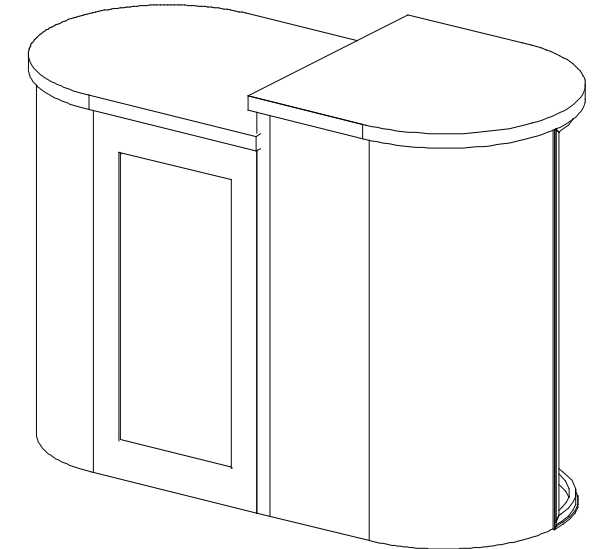

euro lt | HYBRIDS

Euro LT Hybrids General Setup Instructions

Using Your Setup Instructions

The Euro LT Hybrids Setup Instructions are created specifically for your configuration. They are laid out sequentially in levels, including exploded views, and a logical series of detailed steps to assemble the main structure and components. We encourage you to study the instructions **before** attempting to assemble your exhibit.

Cleaning and Packing Your Display

- 1) When cleaning laminate countertops or panels use mild cleansers and a soft material such as cotton.
- 2) Keep all display components away from extreme heat and long exposure to sunlight to avoid warping and fading.
- 3) Retain all packing material. It will make re-packing much easier and will reduce the likelihood of shipping damage.

Level 1 = Blue
 Level 2 = Red
 Level 3 = Green
 Level 4 = Black

Color Code

The top clip is color coded to distinguish the level. The color coded clip also contains the numbered label

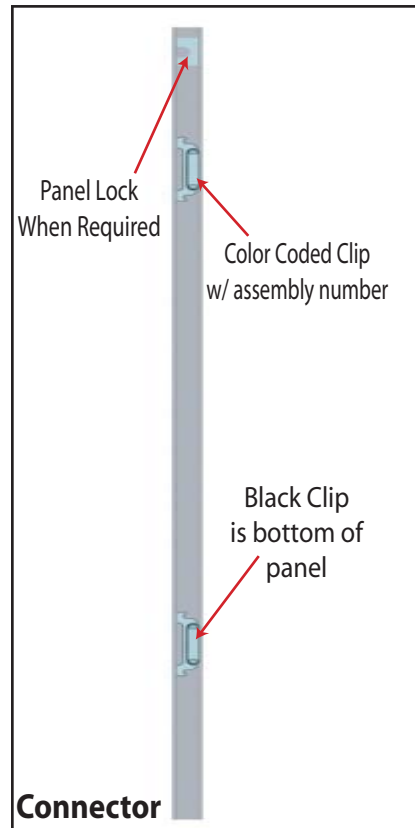

Each component has 2 clips, the lower clip is ALWAYS black..

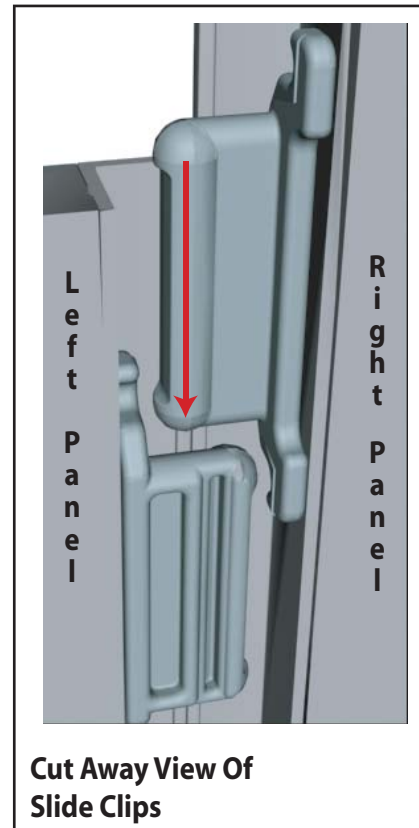

Components connect together by aligning them and sliding downward connecting clips together.

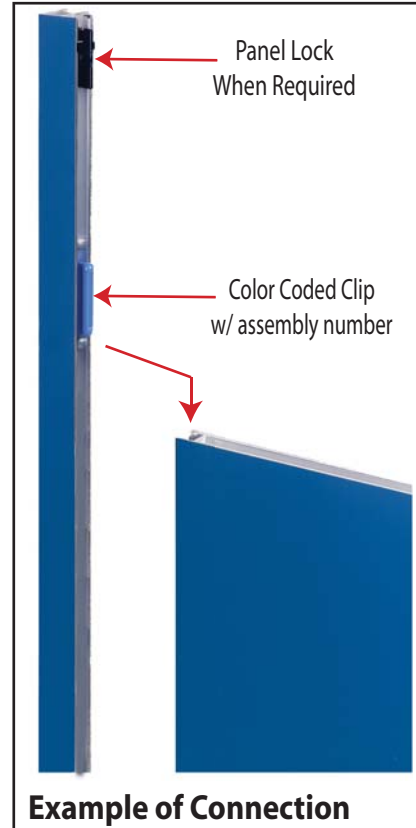

Configurations are assembled from left to right, usually starting with #1 and following the numbered sequence.



The first level of components contains panel locks that are located at the top of the panel for extra stability and a seamless connection. When disassembling panels, twist top connection slightly and lift right panel upward.

