

WHEN DISASSEMBLING ALUMINUM EXTRUSION, TIGHTEN ALL SETSCREWS AND LOCKS TO PREVENT LOSS DURING SHIPPING

# visionary™ IDESIGNS

## Using Your Setup Instructions

The Visionary Designs Setup Instructions are created specifically for your configuration. They are laid out sequentially, including an exploded view of the entire display, and then a logical series of detailed steps to assemble the main structure and components. We encourage you to study the instructions **before** attempting to assemble your exhibit.

Each page reminds you to tighten the setscrews after disassembling your exhibit to prevent loss of the locks and setscrews (see below in RED). This is **VERY IMPORTANT**.

## Cleaning and Packing Your Display

- 1) Use care when cleaning aluminum extrusion or acrylic inserts. Use only non-abrasive cleaners.
- 2) When cleaning laminate inserts or countertops, use mild cleansers and a soft material such as cotton.
- 3) Keep all display components away from extreme heat and long exposure to sunlight to avoid warping and fading.
- 4) Retain all packing material. It will make re-packing much easier and will reduce the likelihood of shipping damage.



**The Tool**

Most Visionary Designs exhibits can be assembled with the supplied Hex Key Tool. Occasionally, a flat head screwdriver may be required.



Detail A

**Typical Connection**



**Typical Connection (cont'd)**

Most horizontal extrusion connections have a patented expandable lock. This lock inserts into the groove of an opposing extrusion. Tightening the lock with the Hex Key Tool expands the lock and creates a strong positive connection.



Detail B

**Numbered Label**

Each extrusion contains a numbered label which corresponds with setup instructions. The label is located within a groove of the extrusion (when possible). With Visionary Designs the labels contain Black numbers unless otherwise specified.



Detail C

**Horizontal Inline Connection** (remove only one setscrew)

Remove only (1) setscrew when disassembling. Replace setscrew in extrusion after assembling it. Before packing, replace setscrew in extrusion to avoid losing it.

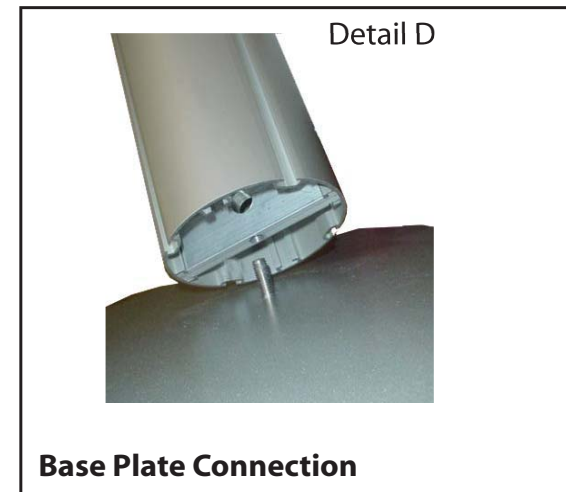

Detail D

**Base Plate Connection**

Attach base plate to round or square vertical extrusion using the bolt provided. Be careful not to strip the threads.



Detail E

**Vertical Connection**  
(remove only two setscrews)

When vertical extrusions are packed in portable cases rather than crates or tubs, they must be broken down into smaller sections which then require assembly.

Remove only (2) setscrews when disassembling. Replace setscrews in extrusion after assembling it. Before packing, replace setscrews in extrusion to avoid losing them.

**WHEN DISASSEMBLING ALUMINUM EXTRUSION, TIGHTEN ALL SETSCREWS AND LOCKS TO PREVENT LOSS DURING SHIPPING**

Part Number	Description
1	Oval Base with 2 Holes
2	Oval Base
3	41.875"h Round Vertical
4	41.875"h Round Vertical
5	41.875"h Round Vertical
6	41.875"h Round Vertical
7	Tapered Counter Support
8	19" Horizontal Extrusion
8A	5" Horizontal Extrusion
9a/9b	46" Horizontal Extrusion
10a/10b	46" Horizontal Extrusion
11a/11b	40.084" Horizontal Extrusion

Steps:

- 1) Connect vertical extrusions [3 to 4 and 5 to 6] as shown.
- 2) Attach vertical assemblies [3/4 and 5/6] to Bases [1 and 2]. Refer to Detail D on general info page.
- 3) Attach tapered counter support [7] to Base [1], connecting horizontal extrusion [8] between vertical [3/4] and support [7]. Attach extrusions [8a] to [8] as shown.
- 4) Connect horizontal extrusions [9a to 9b, 10a to 10b, and 11a to 11b].
- 5) Attach horizontal assembly [9a/9b] between and flush to bottom of vertical assemblies [3/4 and 5/6].
- 6) Attach vertical assembly [11a/11b] to the center of horizontal assembly [9a/9b].
- 7) Attach horizontal assembly [10a/10b] atop vertical [11a/11b] and between vertical assemblies [3/4 and 5/6].
- 8) Place Counter atop support [7 and 8] and attach to vertical [3/4] using thumbscrew attachment.

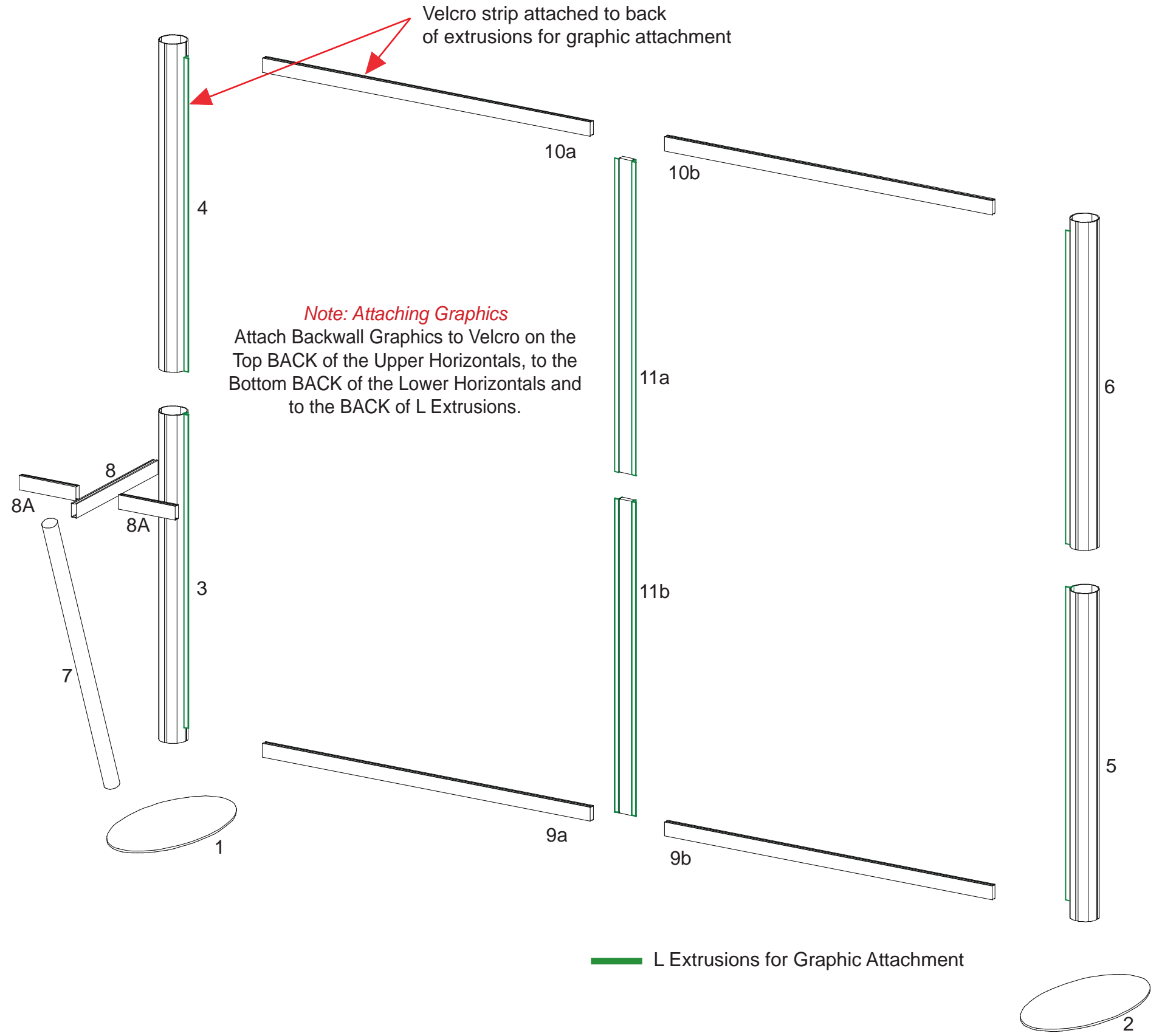
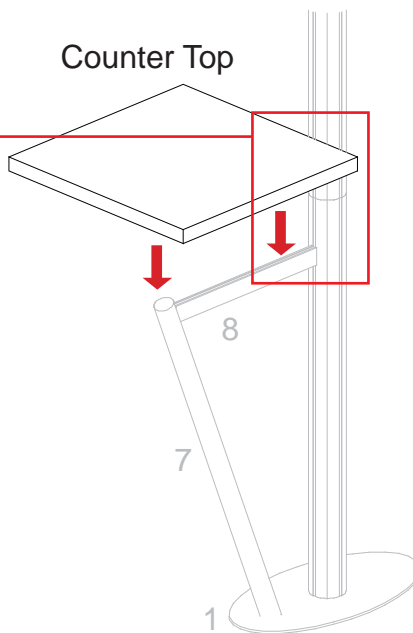
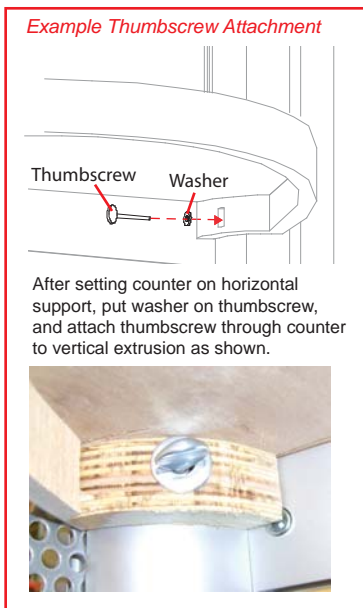

**WHEN DISASSEMBLING ALUMINUM EXTRUSION, TIGHTEN ALL SETSCREWS AND LOCKS TO PREVENT LOSS DURING SHIPPING**

866.652.2100

Item	Quantity	Description
A	1	Round formed extrusion
AB	1	Round formed extrusion
B	1	Round fomred extrusion
C	1	Round formed extrusion
CD	1	Round formed extrusion
D	1	Round formed extrusion
E	1	T-Shaped extrusion
F	1	Round extrusion
G	1	T-Shaped extrusion

Steps:

- 1) Connect (A) round extrusion to (A) round extrusion.
- 2) Connect (B) round extrusion to (B) round extrusion.
- 3) Connect (C) round extrusion to (C) round extrusion.
- 4) Connect (D) round extrusion to (D) round extrusion.
- 5) Connect (A) round extrusion and (D) round extrusion to (G) extrusion.
- 6) Place smaller Plex insert as shown.
- 7) Connect (AB) round extrusion and (CD) round extrusion to (F) extrusion.
- 8) Connect (B) round extrusion and (C) round extrusion to (E) extrusion.
- 9) Place Plex insert as shown.
- 10) Attach Canopy Assembly to Vertical extrusions with Canopy attachments.

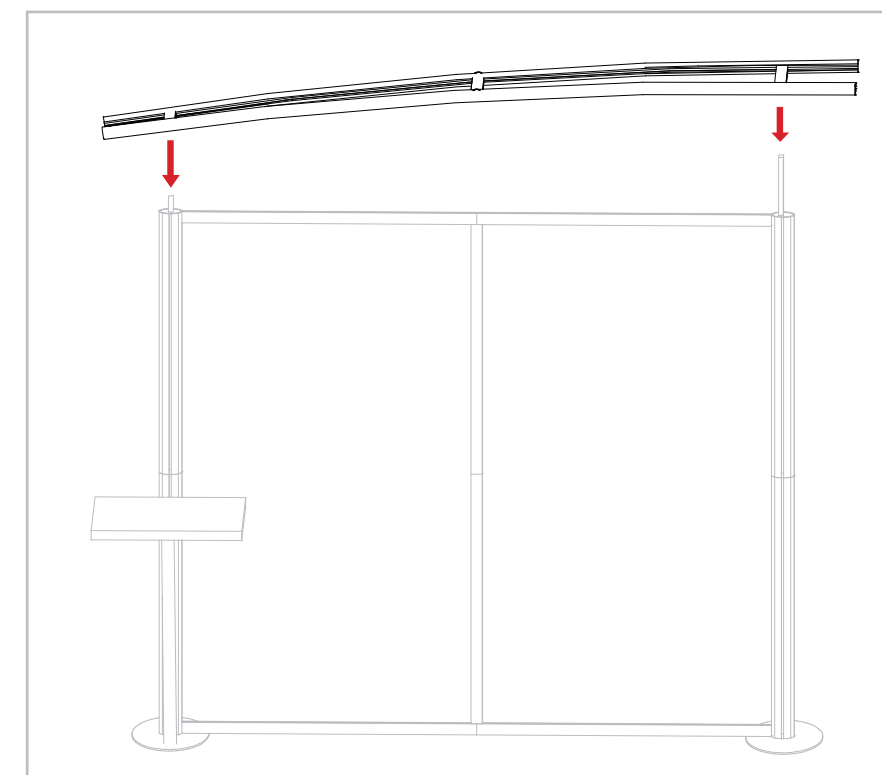
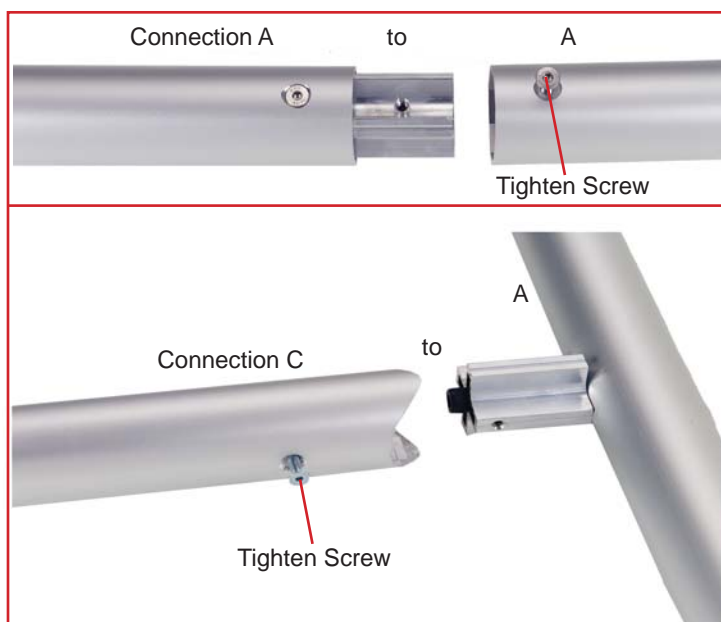
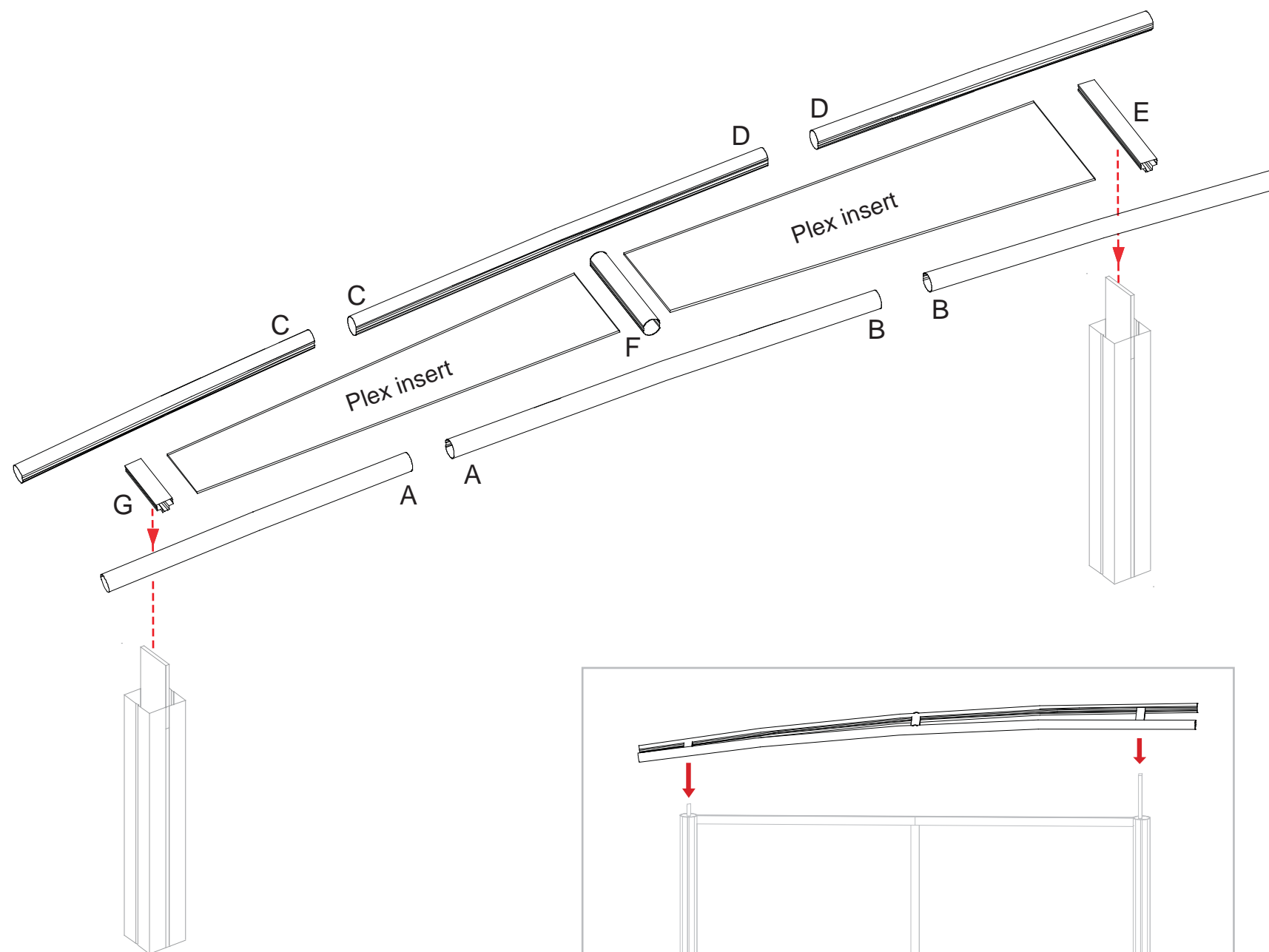

**WHEN DISASSEMBLING ALUMINUM EXTRUSION, TIGHTEN ALL SETSCREWS AND LOCKS TO PREVENT LOSS DURING SHIPPING**

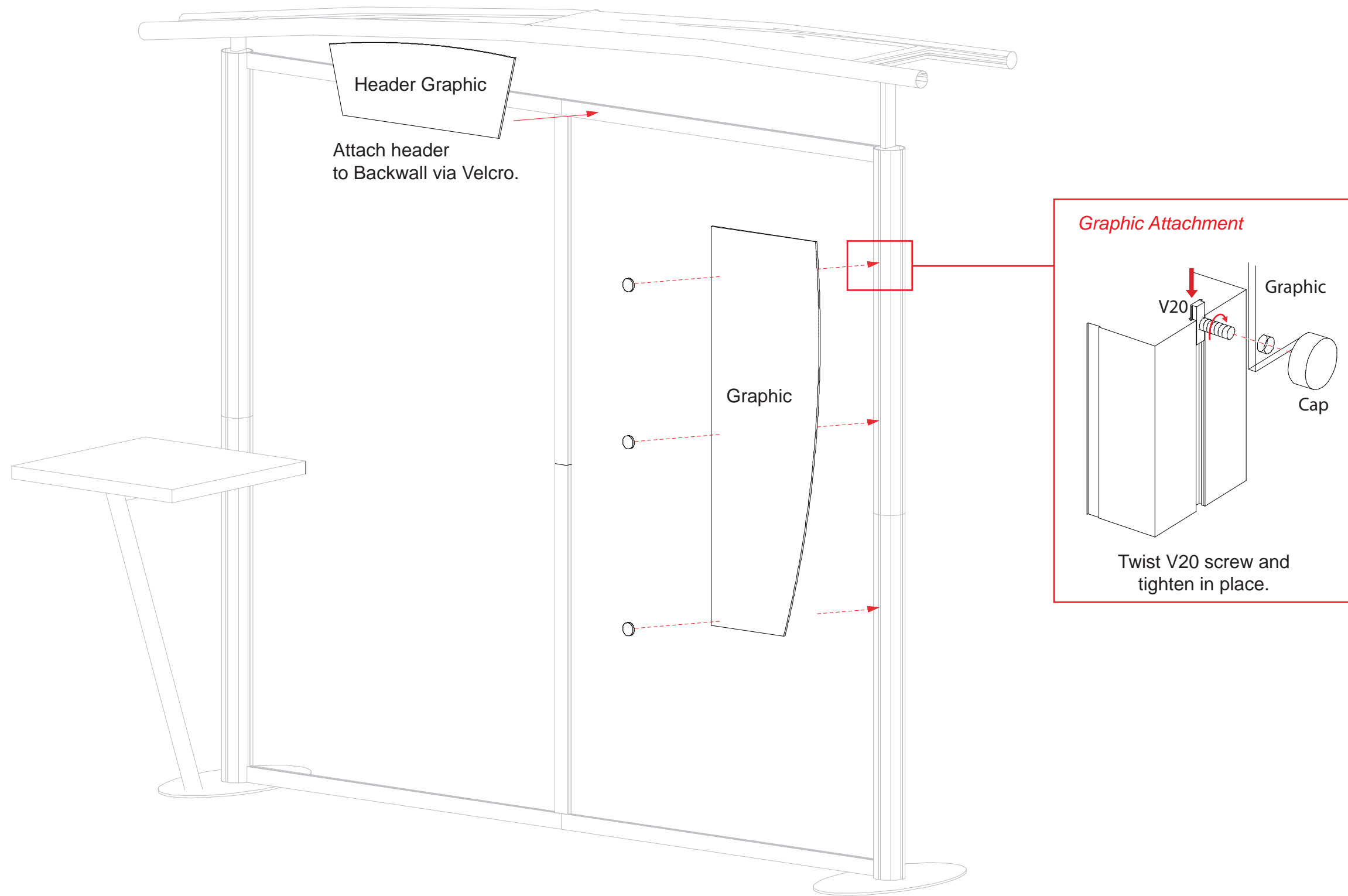

WHEN DISASSEMBLING ALUMINUM EXTRUSION, TIGHTEN ALL SETSCREWS AND LOCKS TO PREVENT LOSS DURING SHIPPING

866.652.2100

Part Number	Description
A	Left Leg Assembly
B	Right Leg Assembly
C	Horizontal Extrusion
D	Horizontal Extrusion w/ Door Stopper
F	Horizontal Extrusion

Step 1:

- A) Connect lower horizontal extrusion [C] between bottom of leg assemblies [A and B] as shown.
- B) Connect upper horizontal extrusion [F] between top of leg assemblies [A and B] as shown.
- C) Insert Laminated infill into grooves of leg assemblies [A and B].
- D) Attach extrusion door between leg assemblies [A and B] and atop laminated infill.
- E) Attach upper horizontal extrusion w/ door stopper [D] between leg assemblies [A and B], and set flush with top of legs [A and B].

**NOTE: Make sure the lock is flush with extrusion before tightening. If lock will not fully engage, gently rock lock and extrusion back and forth while turning knob until lock fully opens.**

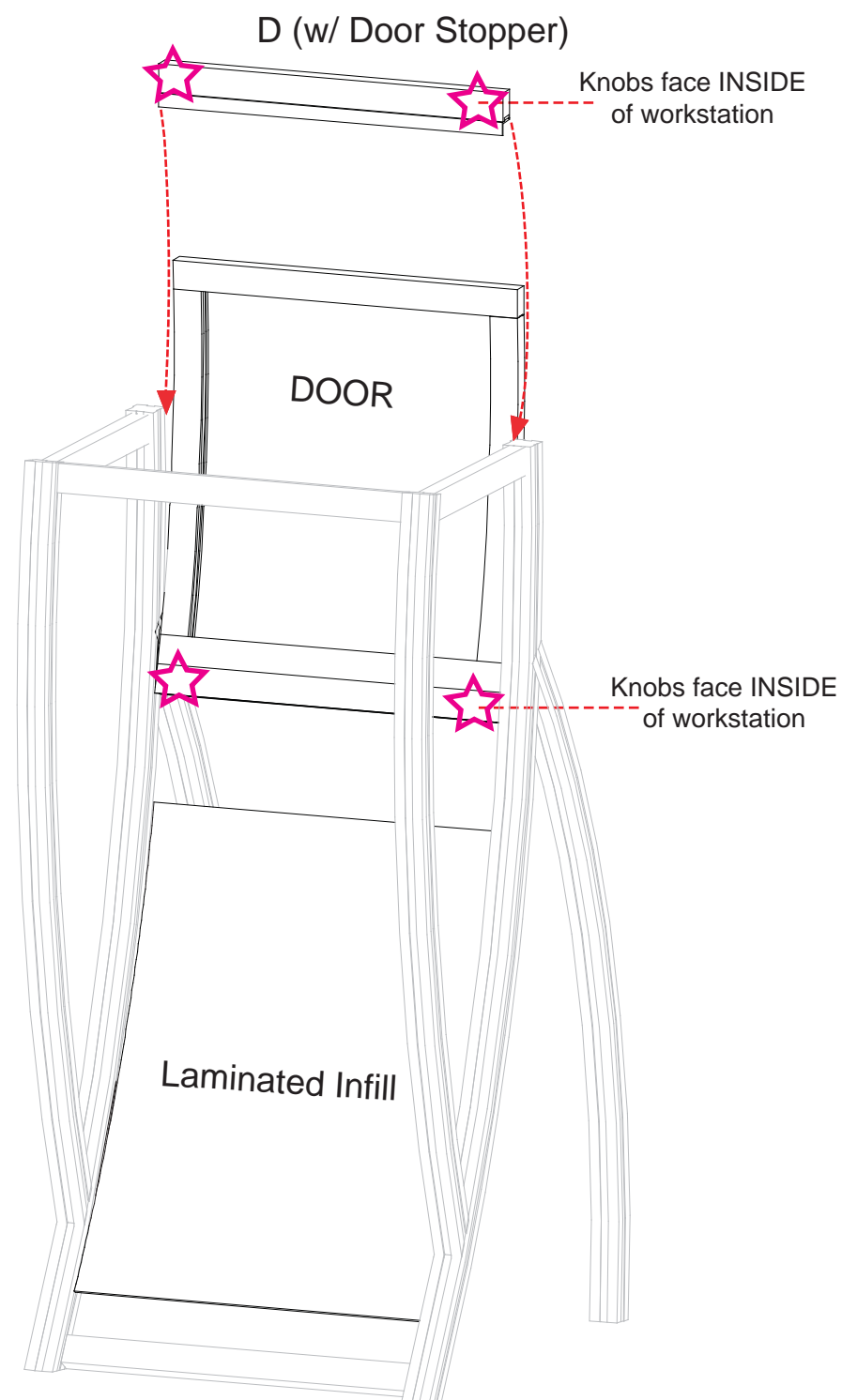
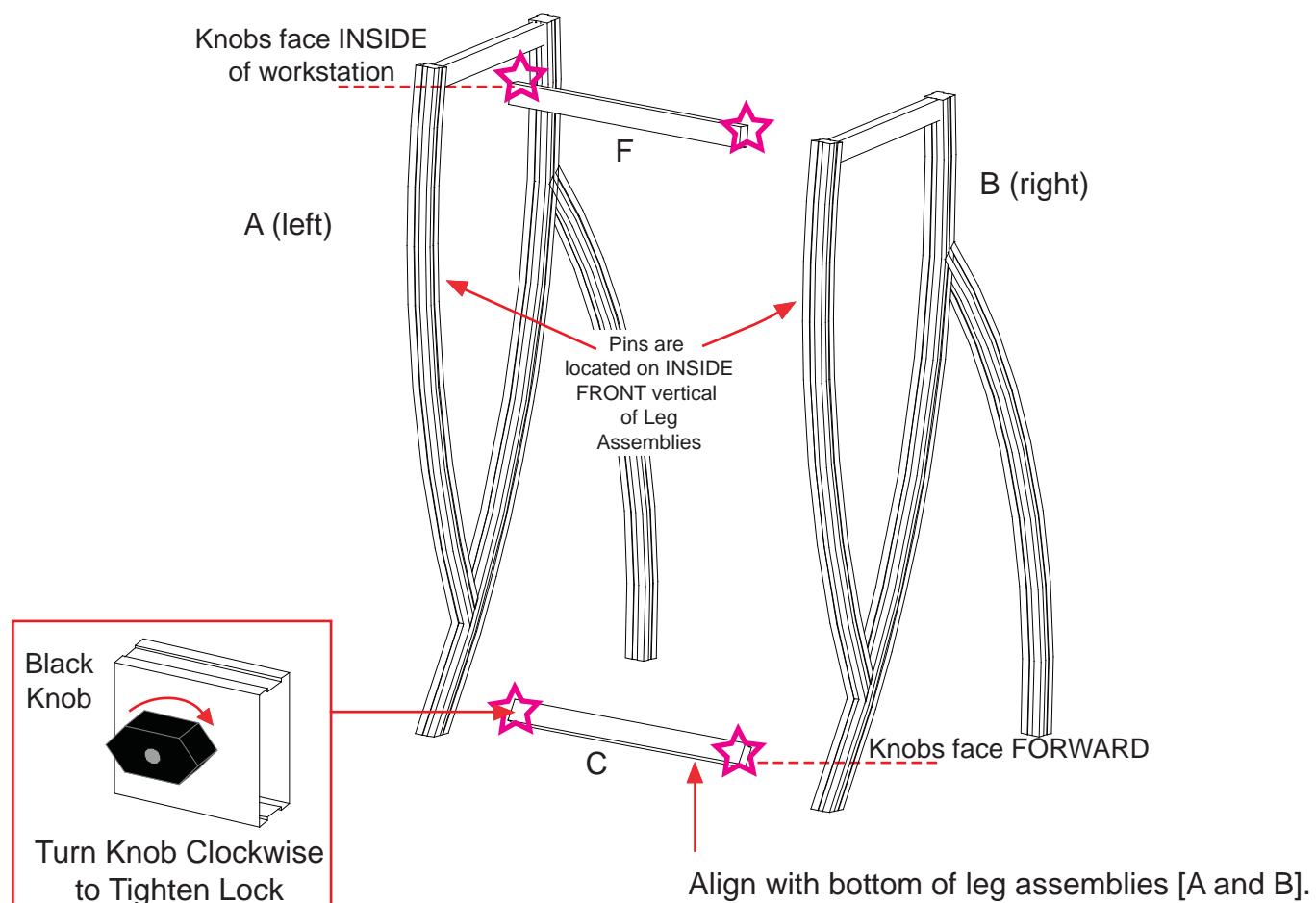

**WHEN DISASSEMBLING ALUMINUM EXTRUSION, TIGHTEN ALL SETSCREWS AND LOCKS TO PREVENT LOSS DURING SHIPPING**

866.652.2100

Part Number	Description
E	Horizontal Extrusion
F	Horizontal Extrusion

- Step 2:
- A) Attach horizontal extrusion [E] between vertical leg assemblies [A and B] as shown below.
  - B) Insert Laminated infill into grooves of vertical leg assemblies [A and B].
  - C) Attach upper horizontal extrusion [F] between vertical leg assemblies [A and B] atop infill.
  - D) Place internal shelf into assembled pedestal atop pins..
  - E) Set Counter atop assembled pedestal and secure with Velcro straps attached to underside of top.

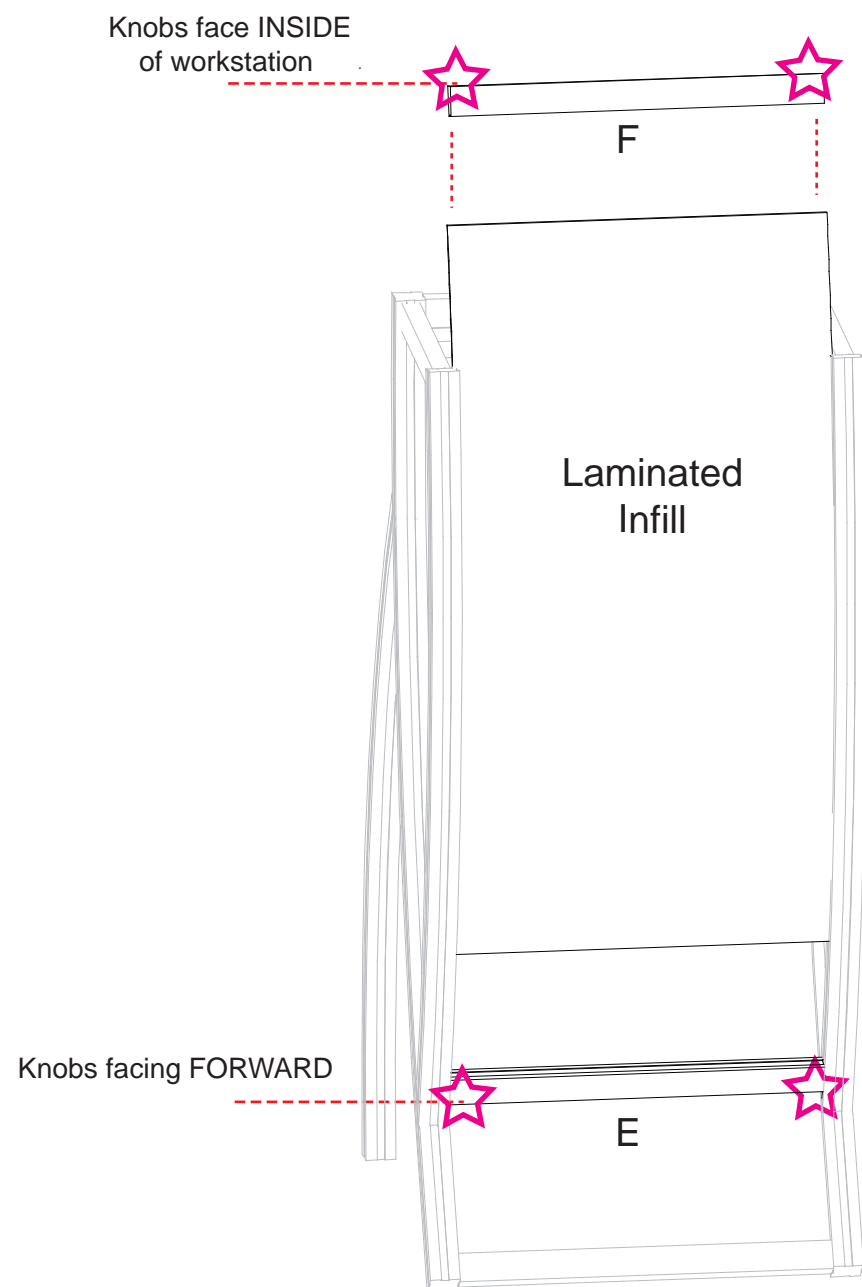

Place internal shelf into workstation then place counter atop assembled workstation.

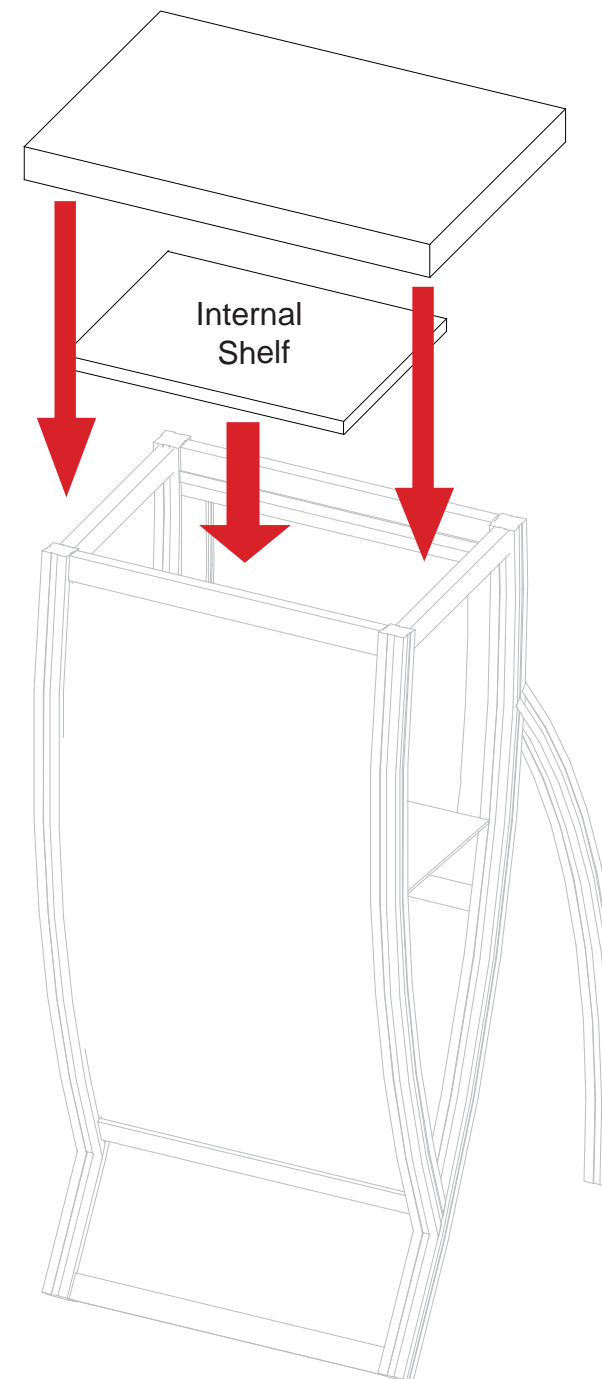

**WHEN DISASSEMBLING ALUMINUM EXTRUSION, TIGHTEN ALL SETSCREWS AND LOCKS TO PREVENT LOSS DURING SHIPPING**

Part Number	Description
G	Curved Monitor Mount Extrusion

Step 3:

- A) Slide Connection Bar into lower leg assembly. Slide upper vertical over bar and secure both.
- B) Attach Monitor Mount to vertical as shown in Detail below.

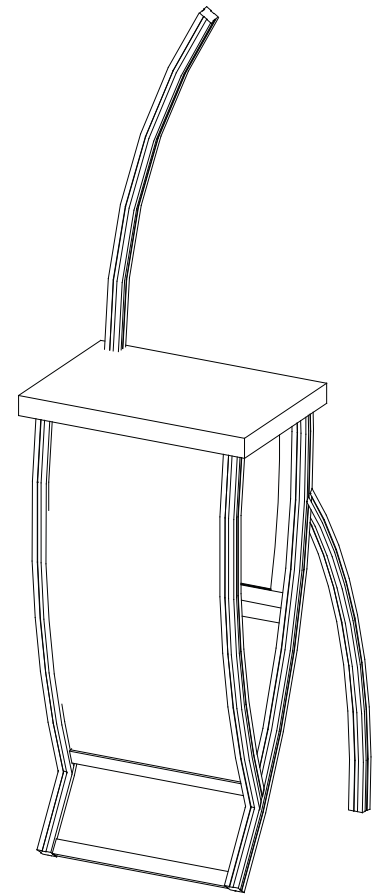

*Monitor Mount Attachment*

NOTE: Monitor mount should be installed while laying down on floor

V20

Adjust V20 connector to desired location. Then remove screws.

Place mount plate in front of V20 connectors. Then secure with screws.

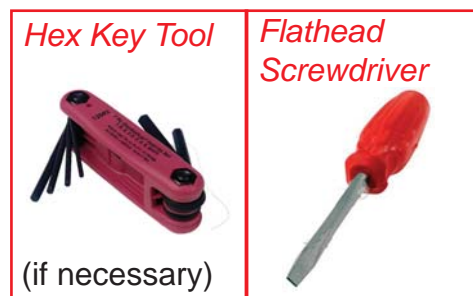
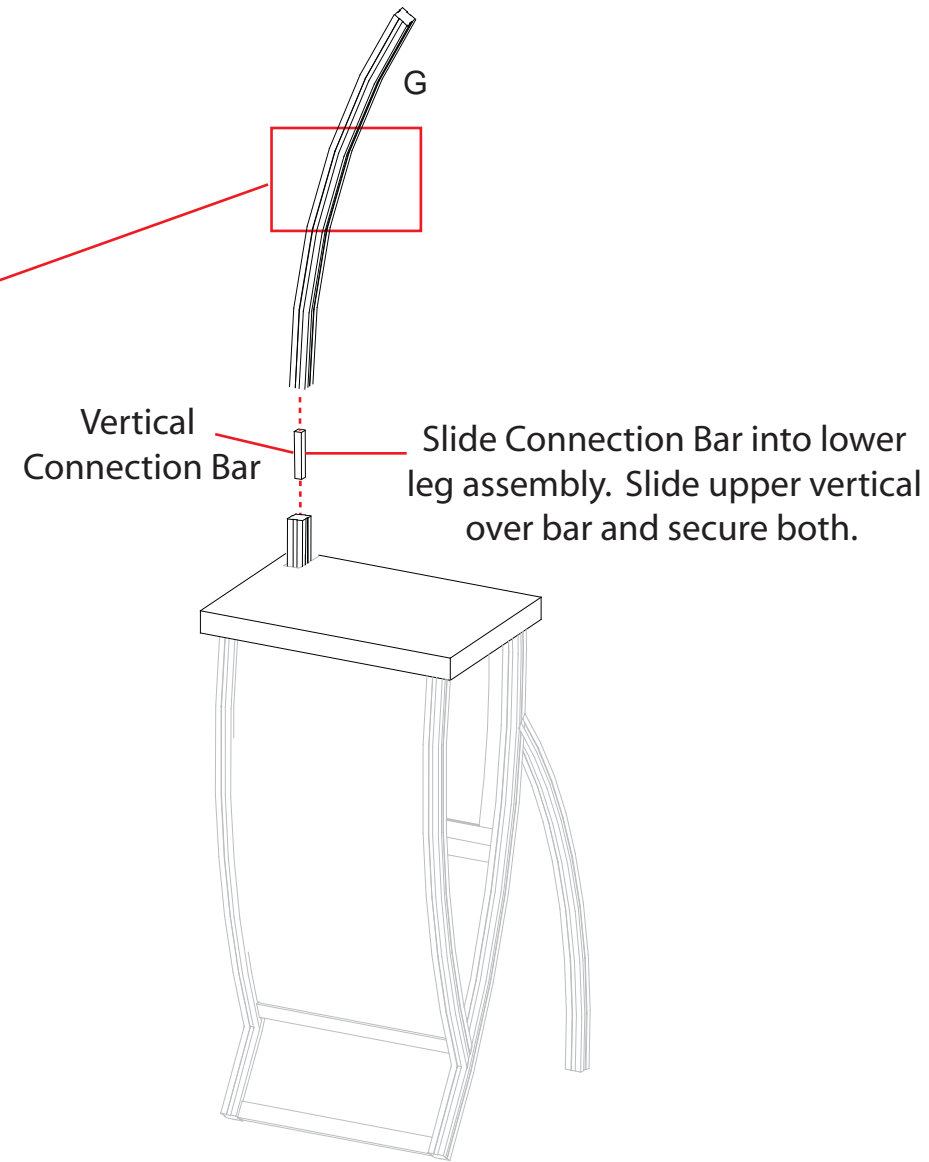

**WHEN DISASSEMBLING ALUMINUM EXTRUSION, TIGHTEN ALL SETSCREWS AND LOCKS TO PREVENT LOSS DURING SHIPPING**

Case 1

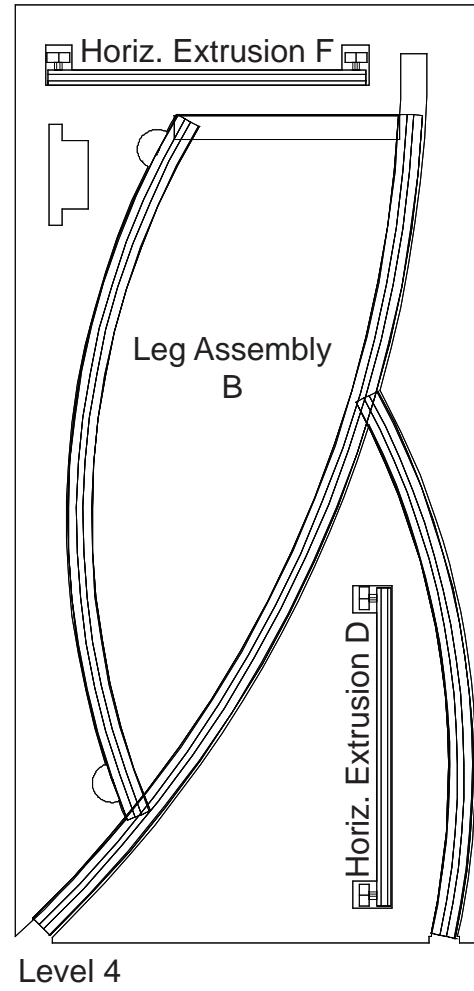
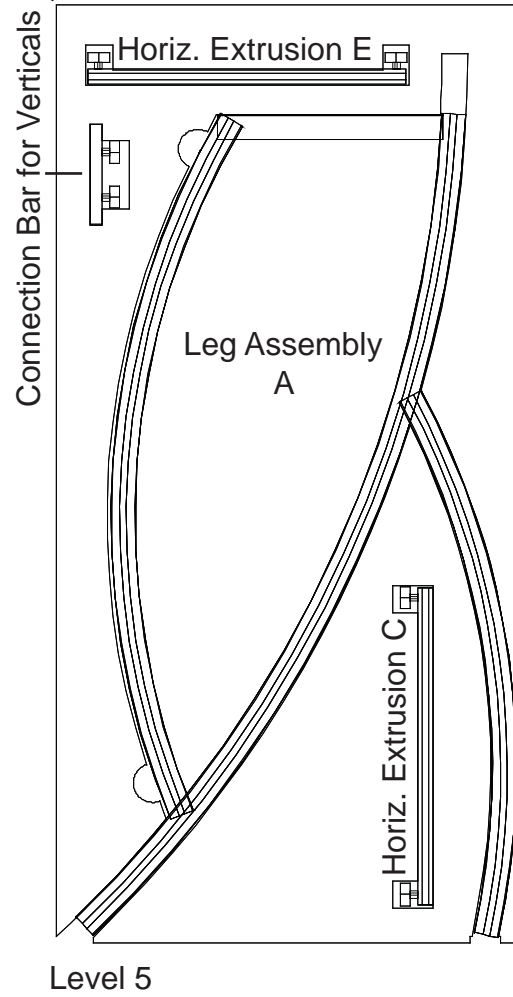

Top View of each Level

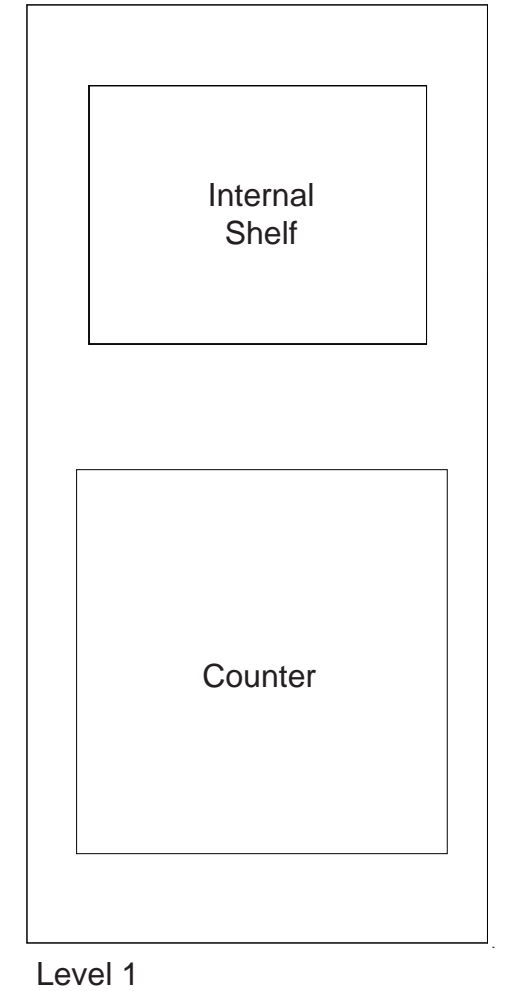
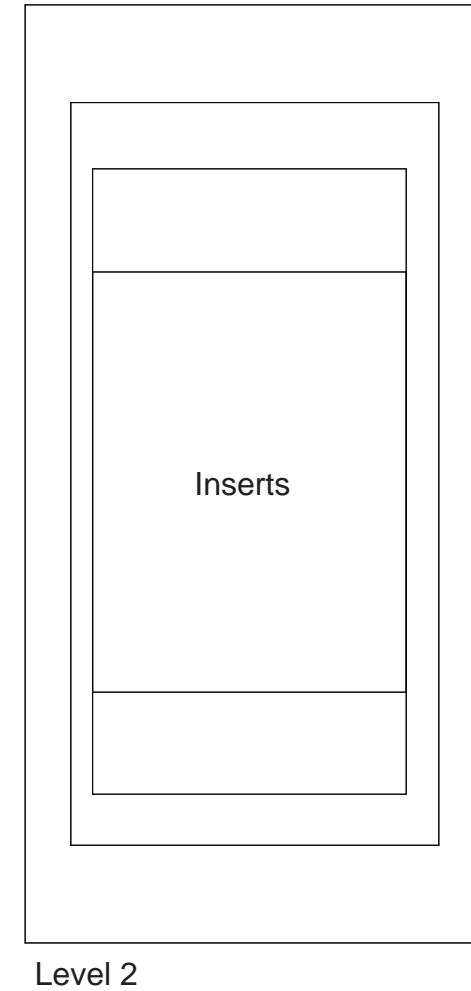
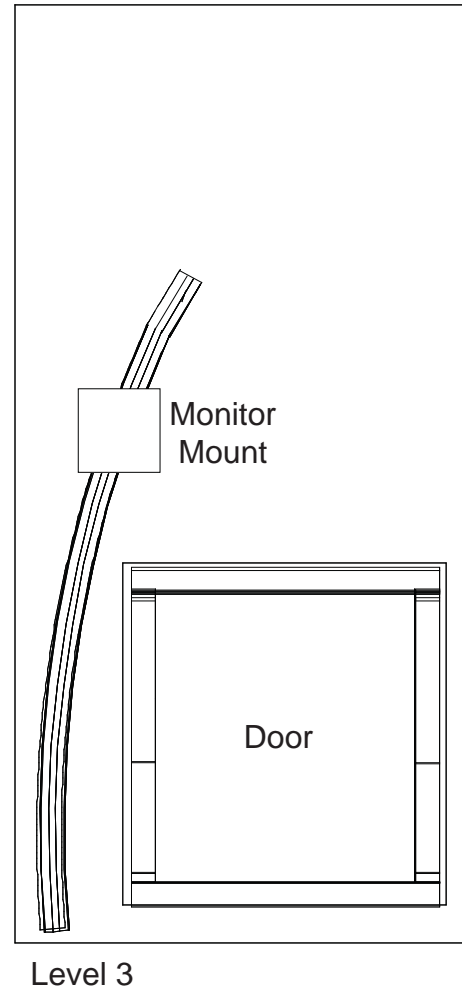

WHEN DISASSEMBLING ALUMINUM EXTRUSION, TIGHTEN ALL SETSCREWS AND LOCKS TO PREVENT LOSS DURING SHIPPING

Case 2

Level 1

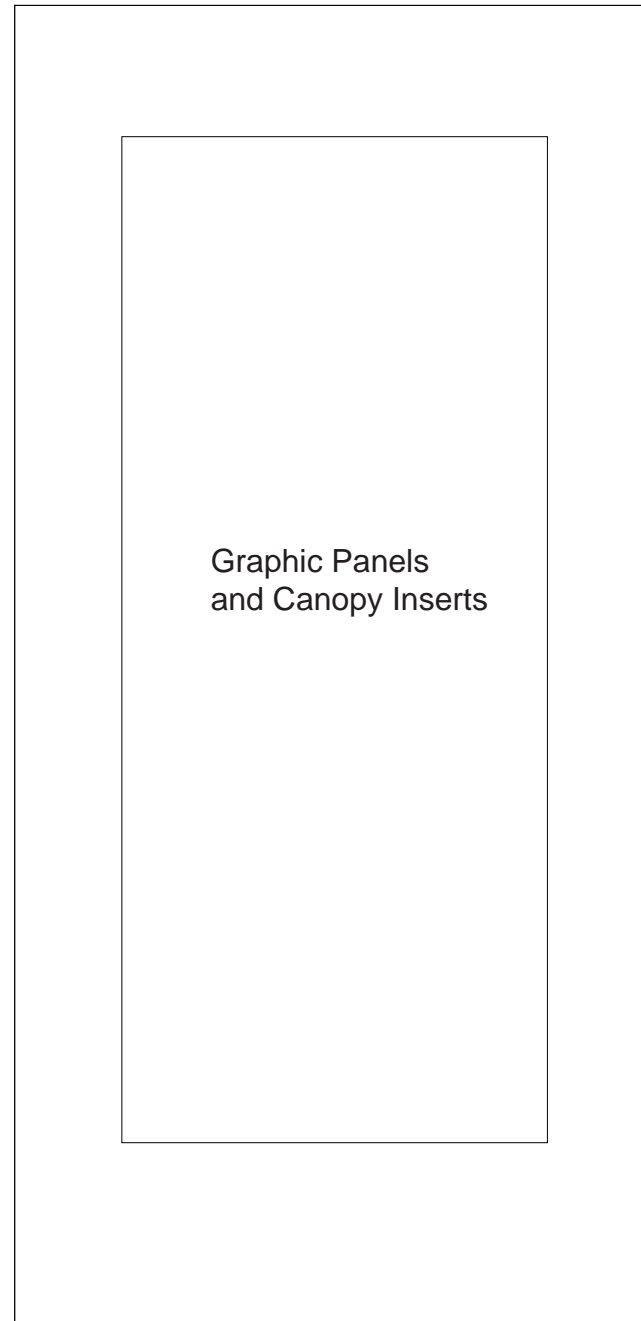

Level 2

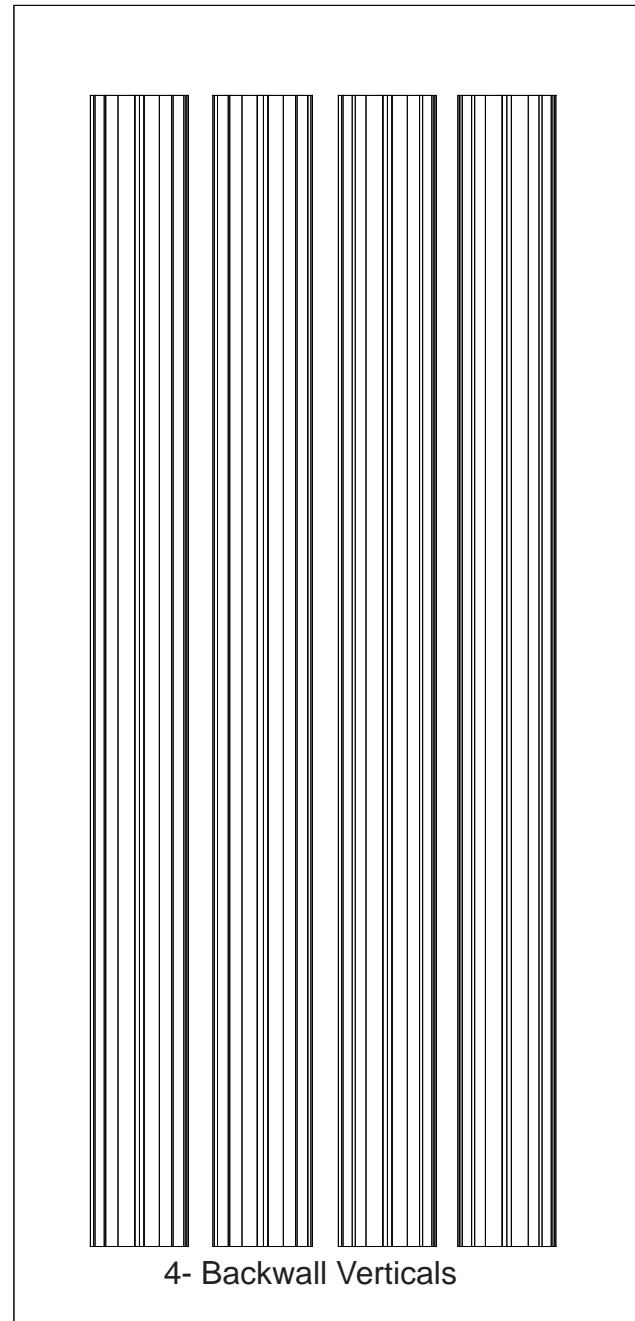

Level 3

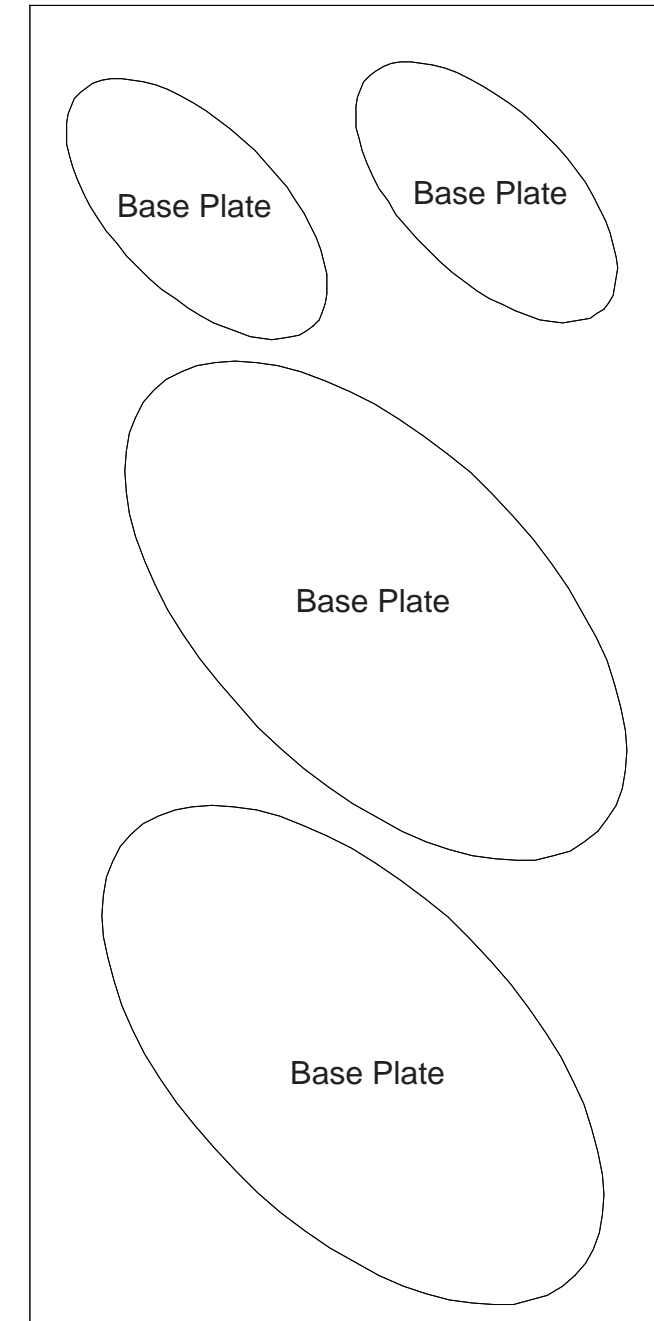

WHEN DISASSEMBLING ALUMINUM EXTRUSION, TIGHTEN ALL SETSCREWS AND LOCKS TO PREVENT LOSS DURING SHIPPING

Case 3

Level 1

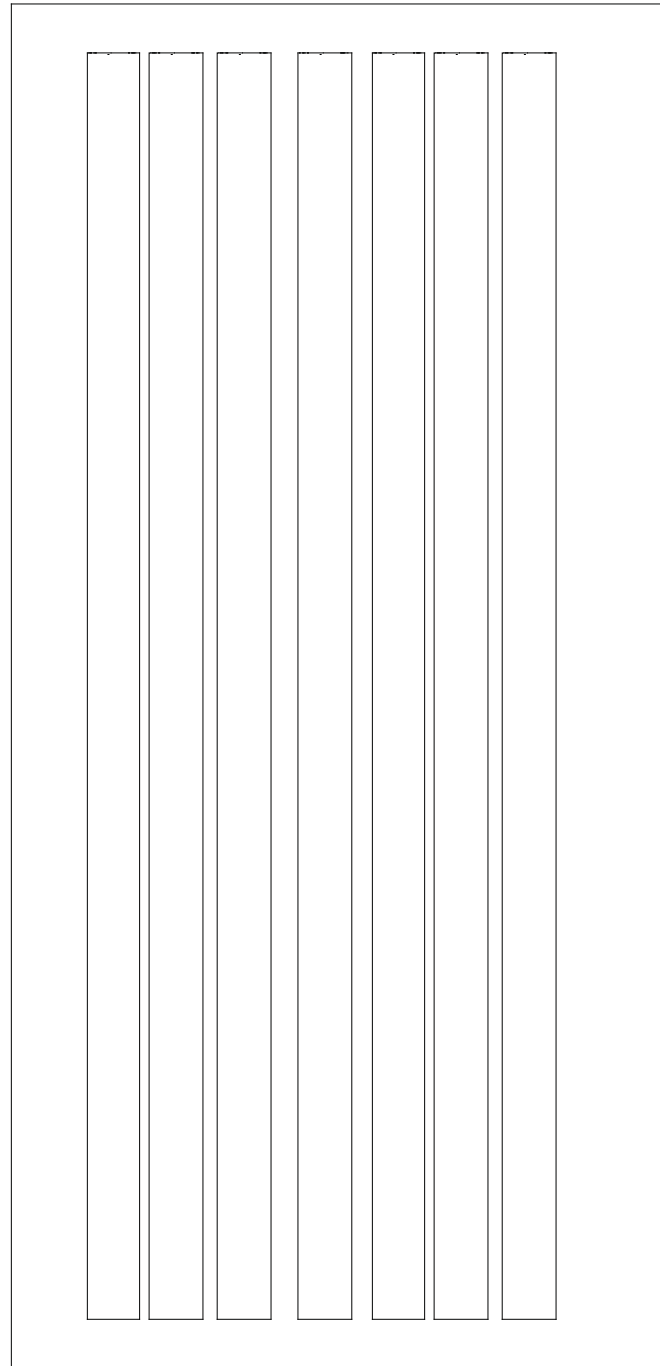

Canopy Extrusions and Tapered Counter Support

Level 2

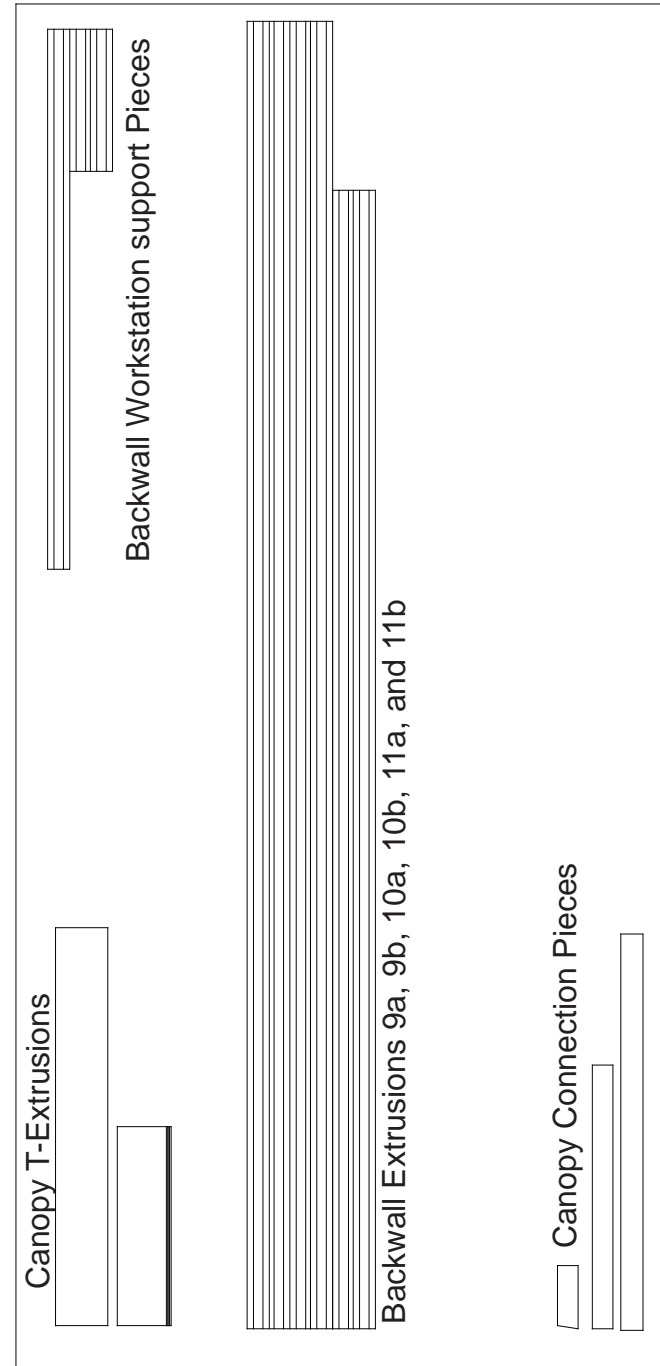

Level 3

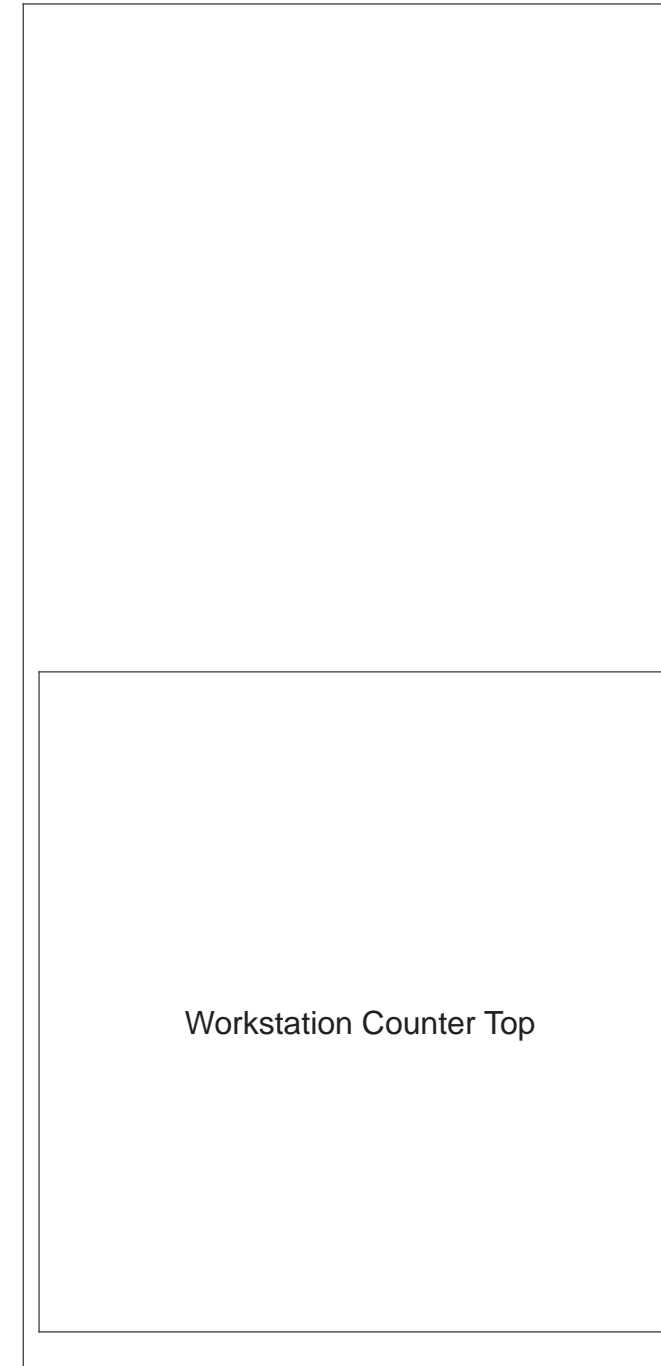

Level 4

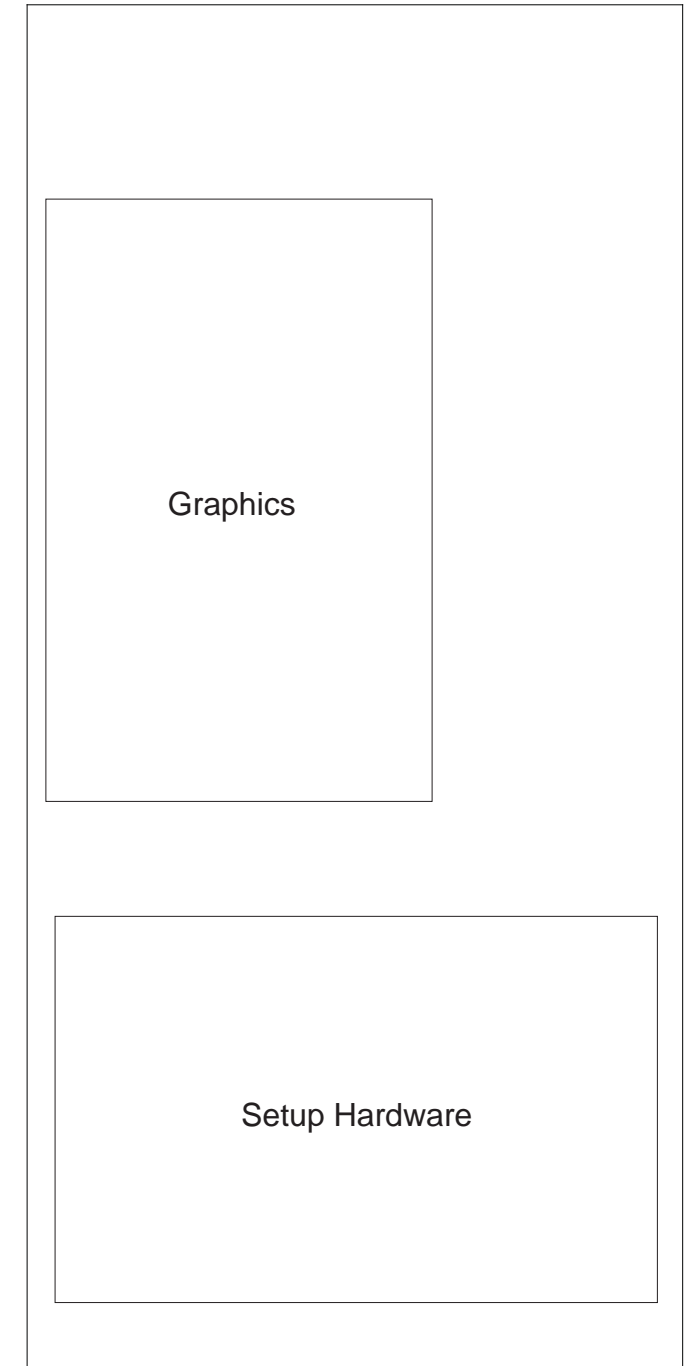

WHEN DISASSEMBLING ALUMINUM EXTRUSION, TIGHTEN ALL SETSCREWS AND LOCKS TO PREVENT LOSS DURING SHIPPING