

**visionary**<sup>™</sup>  
DESIGNS

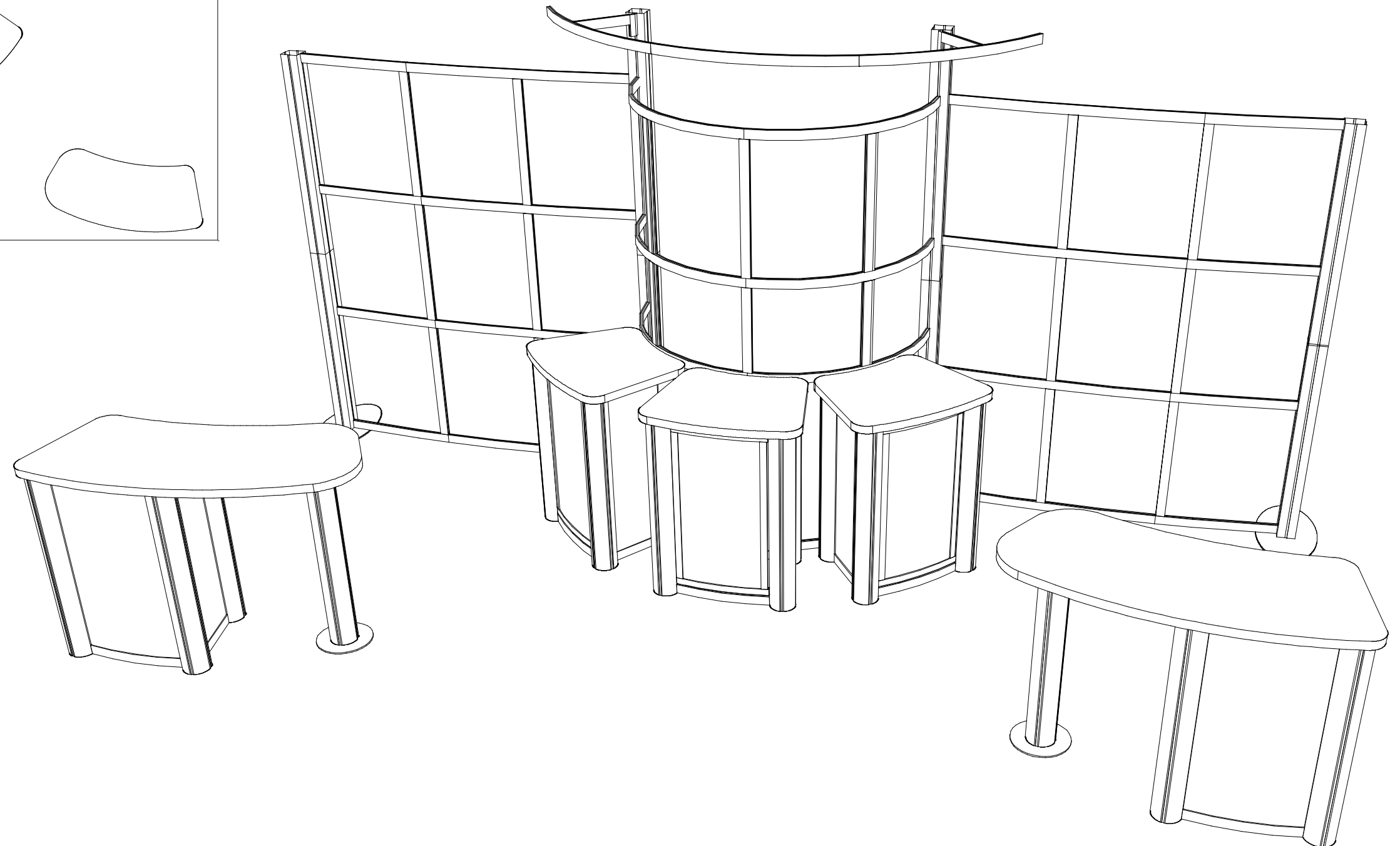
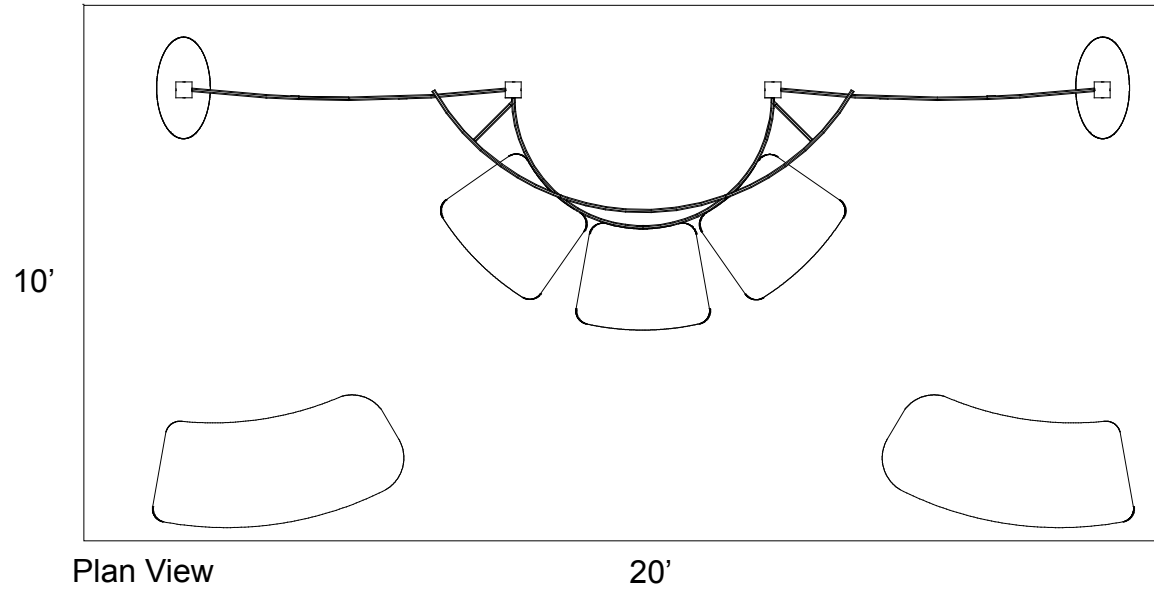

**WHEN DISASSEMBLING ALUMINUM EXTRUSION, TIGHTEN ALL SETSCREWS AND LOCKS TO PREVENT LOSS DURING SHIPPING**

# visionary™ IDESIGNS

## Using Your Setup Instructions

The Visionary Designs Setup Instructions are created specifically for your configuration. They are laid out sequentially, including an exploded view of the entire display, and then a logical series of detailed steps to assemble the main structure and components. We encourage you to study the instructions **before** attempting to assemble your exhibit.

Each page reminds you to tighten the setscrews after disassembling your exhibit to prevent loss of the locks and setscrews (see below in RED). This is **VERY IMPORTANT**.

## Cleaning and Packing Your Display

- 1) Use care when cleaning aluminum extrusion or acrylic inserts. Use only non-abrasive cleaners.
- 2) When cleaning laminate inserts or countertops, use mild cleansers and a soft material such as cotton.
- 3) Keep all display components away from extreme heat and long exposure to sunlight to avoid warping and fading.
- 4) Retain all packing material. It will make re-packing much easier and will reduce the likelihood of shipping damage.



**The Tool**

Most Visionary Designs exhibits can be assembled with the supplied Hex Key Tool. Occasionally, a flat head screwdriver may be required.



Detail A

**Typical Connection**



**Typical Connection (cont'd)**

Most horizontal extrusion connections have a patented expandable lock. This lock inserts into the groove of an opposing extrusion. Tightening the lock with the Hex Key Tool expands the lock and creates a strong positive connection.

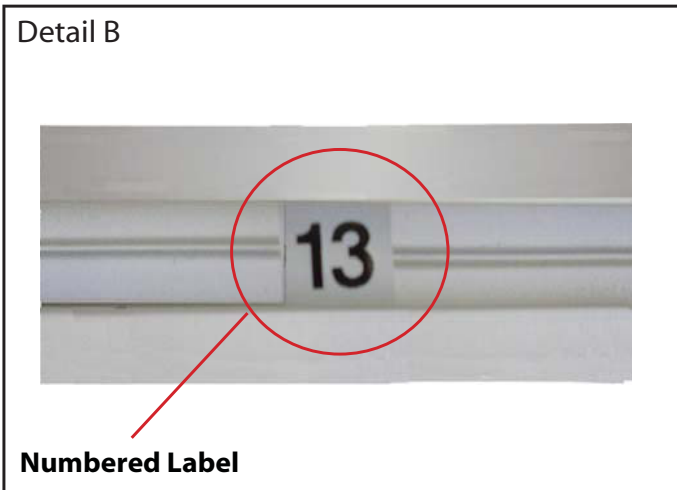

Detail B

**Numbered Label**

Each extrusion contains a numbered label which corresponds with setup instructions. The label is located within a groove of the extrusion (when possible). With Visionary Designs the labels contain Black numbers unless otherwise specified.



Detail C

**Horizontal Inline Connection** (remove only one setscrew)

Remove only (1) setscrew when disassembling. Replace setscrew in extrusion after assembling it. Before packing, replace setscrew in extrusion to avoid losing it.

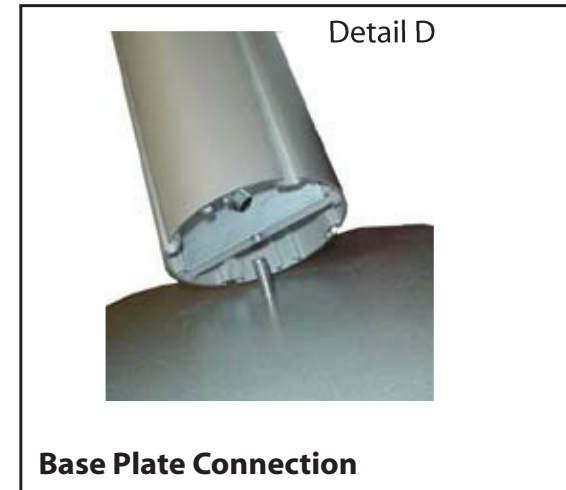

Detail D

**Base Plate Connection**

Attach base plate to round or square vertical extrusion using the bolt provided. Be careful not to strip the threads.

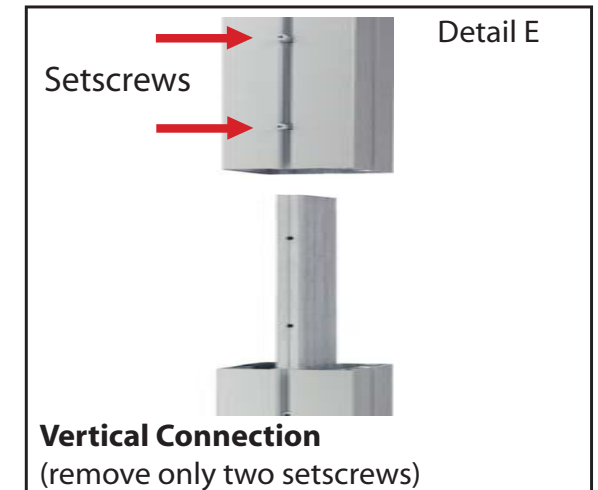

Detail E

**Vertical Connection**  
(remove only two setscrews)

When vertical extrusions are packed in portable cases rather than crates or tubs, they must be broken down into smaller sections which then require assembly.

Remove only (2) setscrews when disassembling. Replace setscrews in extrusion after assembling it. Before packing, replace setscrews in extrusion to avoid losing them.

**WHEN DISASSEMBLING ALUMINUM EXTRUSION, TIGHTEN ALL SETSCREWS AND LOCKS TO PREVENT LOSS DURING SHIPPING**

866.652.2100

Item	Qty.	Description
1	2	Oval Base Plates
2	2	42" h Vertical Extrusion
3	2	42" h Vertical Extrusion
4	1	48" h Vertical Extrusion
5	1	48" h Vertical Extrusion w/ 120° Connector
6	1	48" h Vertical Extrusion
7	1	48" h Vertical Extrusion w/ 120° Connector
8	4	24.0295" w Curved Horizontal Extrusion
9	4	46.1219" w Curved Horizontal Extrusion
10	12	25.528" h Vertical Extrusion
11	4	46.1219" w Curved Horizontal Extrusion
12	4	24.0295" w Curved Horizontal Extrusion
13	4	46.14" w Curved Horizontal Extrusion
14	4	46.14" w Curved Horizontal Extrusion
15	3	34.167" h Vertical Extrusion
16	3	16.889" h Vertical Extrusion
17	3	25.528" h Vertical Extrusion

Steps:

- 1) Connect Vertical extrusions [2 to 3, 4 to 5 and 6 to 7].
- 2) Connect vertical assemblies [2/3] to oval base plates [1] as shown in Detail D on the general info page.
- 3) Connect horizontal extrusions [8 to 9, 11 to 12, and 13 to 14] as shown below.
- 4) Connect lower curved horizontal assemblies [8/9, 11/12, and 13/14] as shown between vertical extrusions [2, 4 and 6].
- 5) Connect vertical extrusions [10 and 15] to horizontal assemblies [8/9, 11/12, and 13/14] as shown, fitting graphic panels in between, then continue by repeating steps 4 and 5 with remaining extrusions [8/9, 11/12, 13/14, 10, 16 and 17].

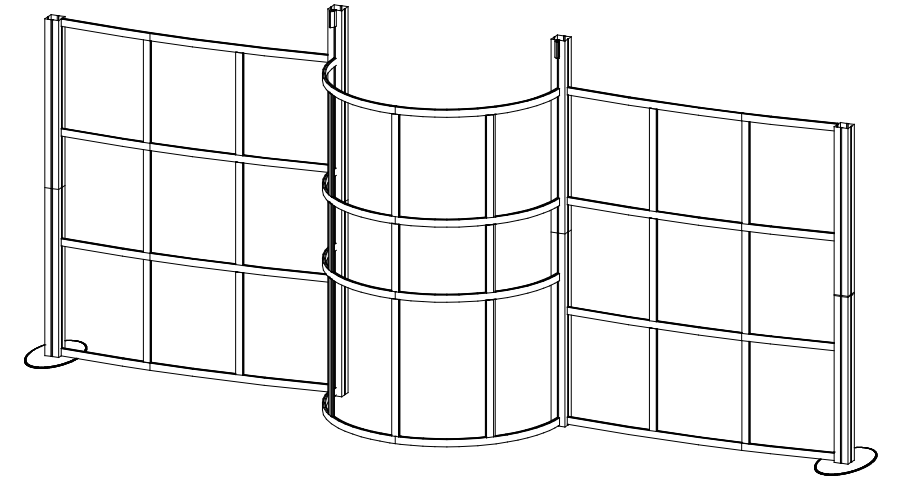

Back Lighting Assembly

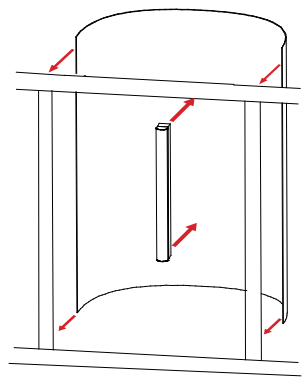

Attach reflector to back of extrusion with velcro at sides. Velcro light to reflector as shown.

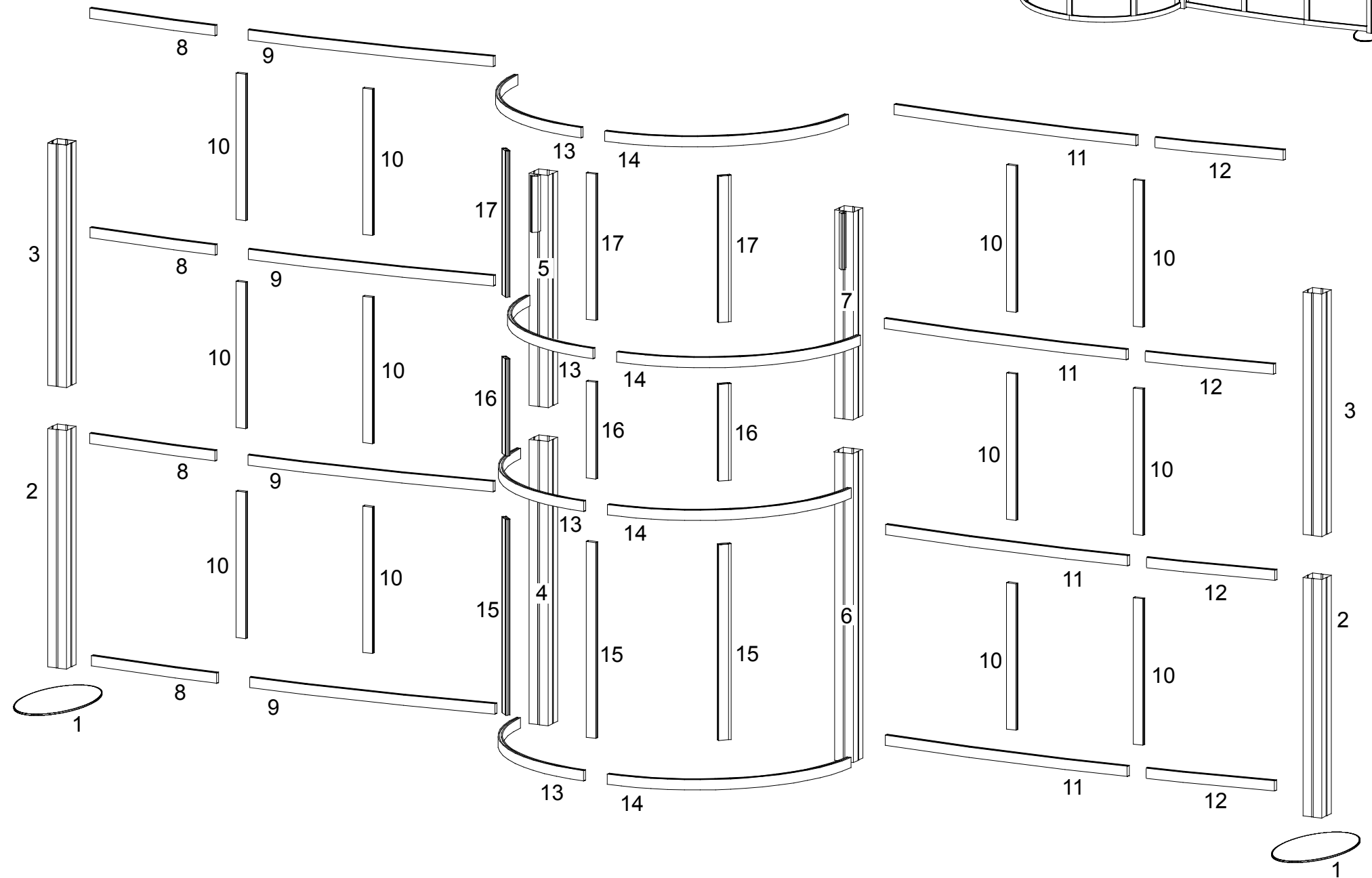

**WHEN DISASSEMBLING ALUMINUM EXTRUSION, TIGHTEN ALL SETSCREWS AND LOCKS TO PREVENT LOSS DURING SHIPPING**

866.652.2100

Item	Qty.	Description
18	2	11.2164"w Horizontal Extrusion
19	1	37.73"w Curved Horizontal Extrusion
20	1	37.73"w Curved Horizontal Extrusion
21	1	37.73"w Curved Horizontal Extrusion

## Steps:

- 1) Connect extrusions [18] to backwall making flush to Top of 120° extrusion.
- 2) Connect curved extrusions [19, 20, and 21] together then attach to horizontal extrusions [18] as shown.

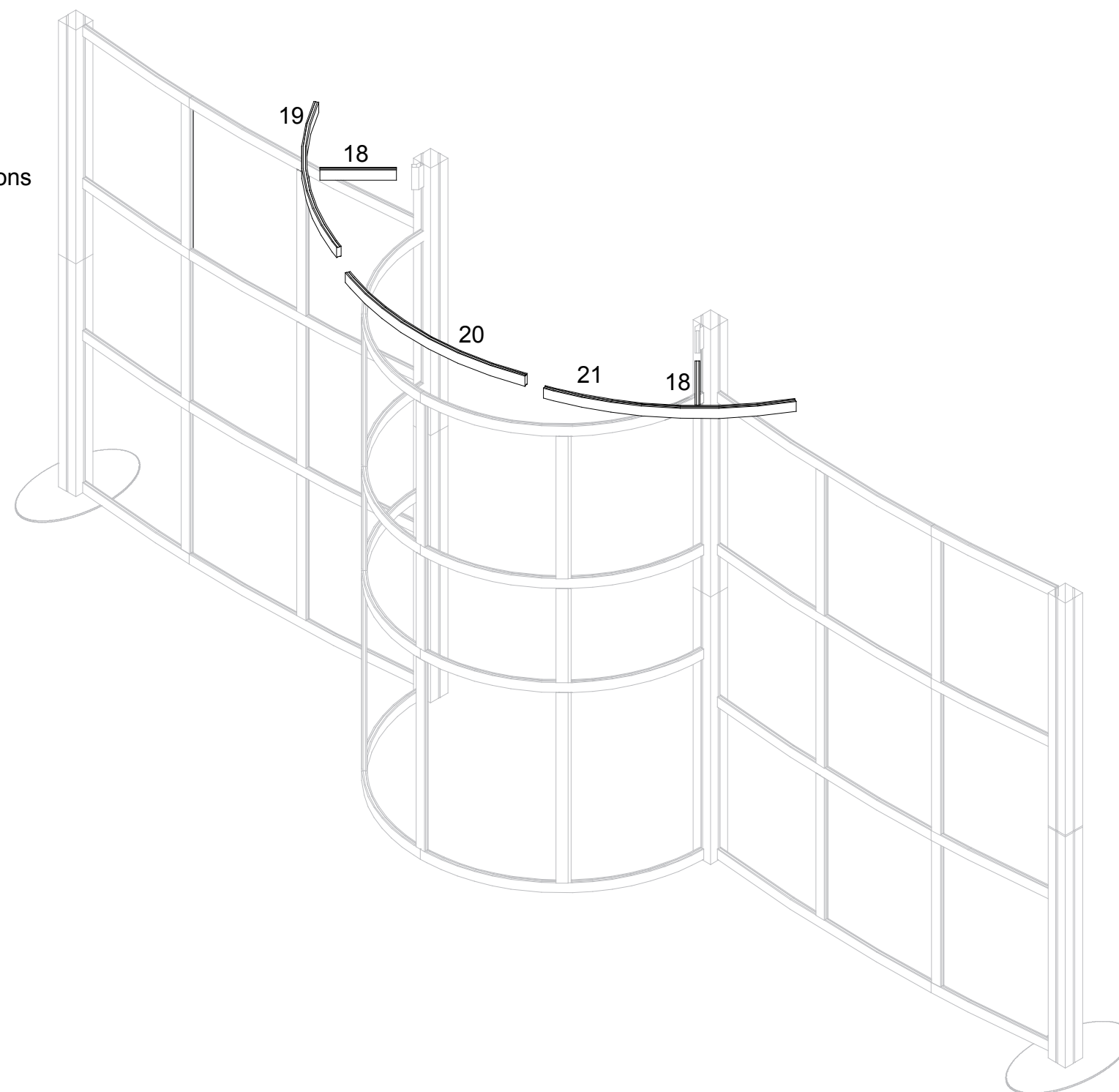

WHEN DISASSEMBLING ALUMINUM EXTRUSION, TIGHTEN ALL  
SETSCREWS AND LOCKS TO PREVENT LOSS DURING SHIPPING

866.652.2100

Item	Qty.	Description
22	1	37" h Vertical Extrusion w/ Door Stopper
23	1	37" h Vertical Extrusion
24	1	37" h Vertical Extrusion
25	1	37" h Vertical Extrusion w/ Hinges
26	4	11.8094" w Horizontal Extrusion
27	2	12.1599" w Curved Horizontal Extrusion
28	2	18.0687" w Curved Horizontal Extrusion

Steps:

- 1) Attach lower horizontal extrusions [26, 27 and 28] between vertical extrusions [22, 23, 24 and 25].
- 2) Place inserts and door between vertical extrusions as shown.
- 3) Attach upper horizontal extrusions [26, 27 and 28] between vertical extrusions [22, 23, 24 and 25] and atop inserts and door.
- 4) Velcro shelf supports to inside of assembled base.
- 5) Place internal shelf atop supports.
- 6) Set counter top on assembled pedestal as shown.

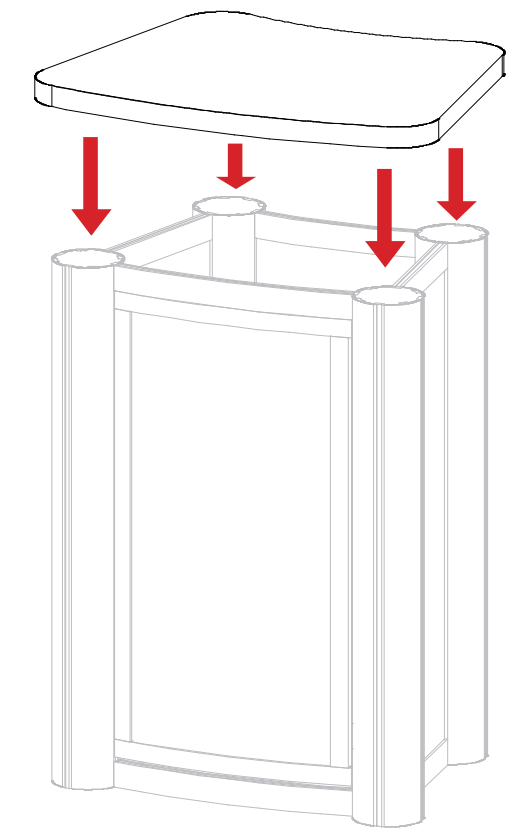
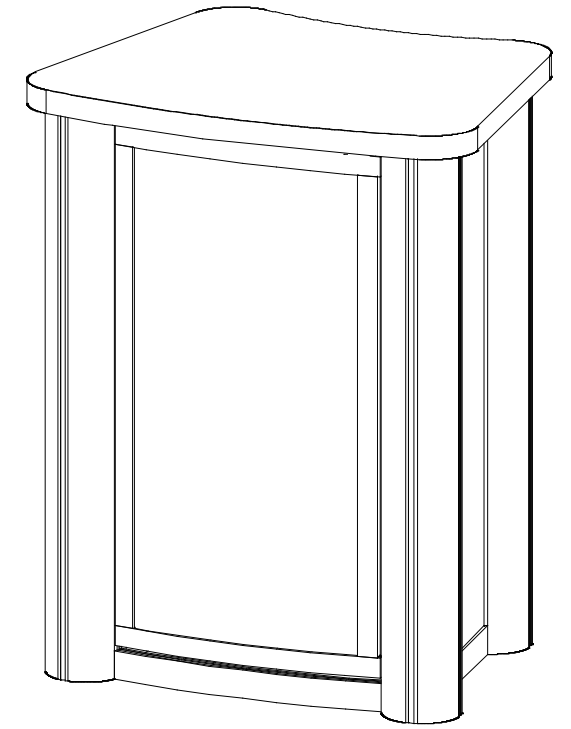
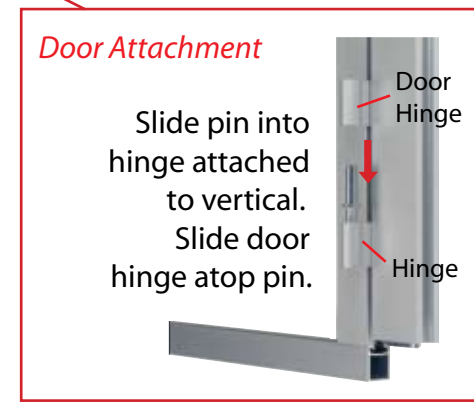
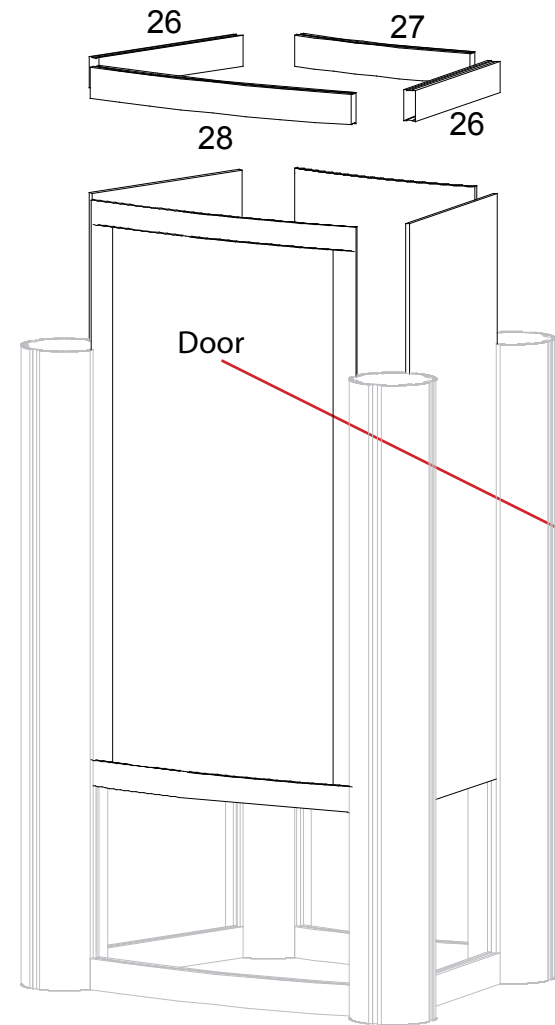
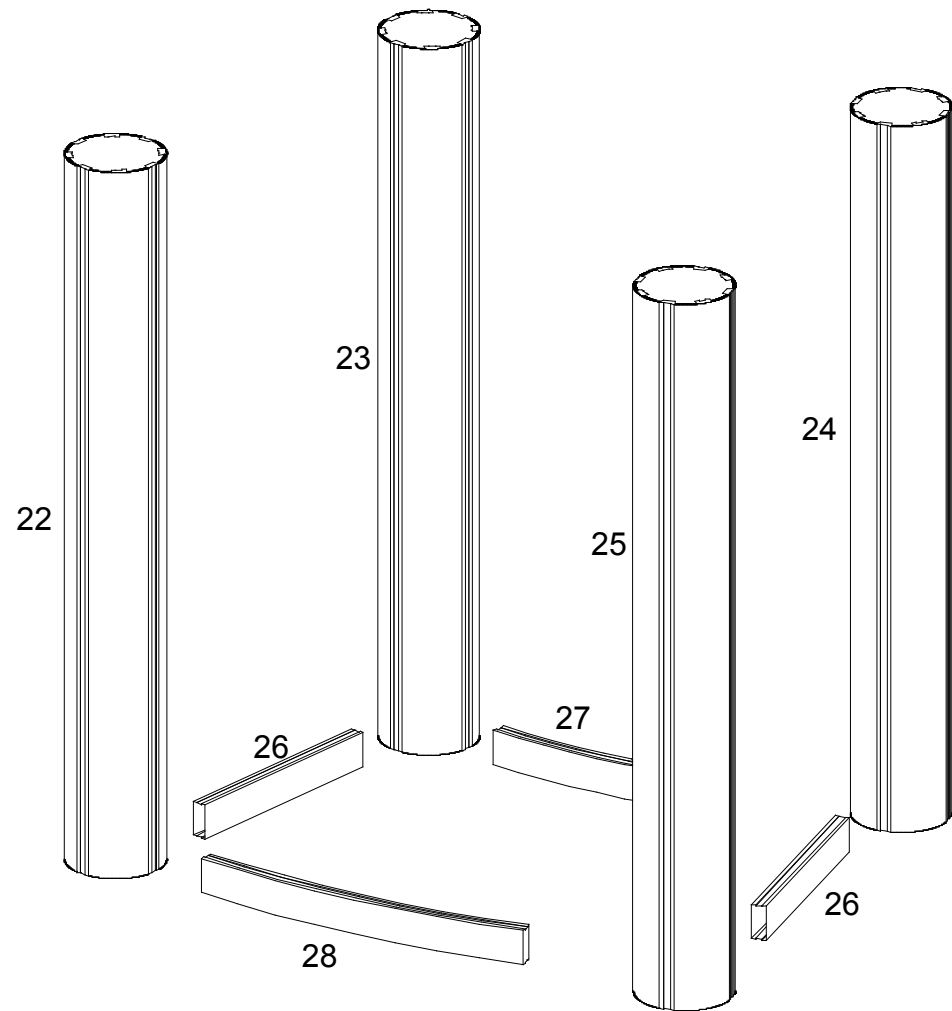

**WHEN DISASSEMBLING ALUMINUM EXTRUSION, TIGHTEN ALL SETSCREWS AND LOCKS TO PREVENT LOSS DURING SHIPPING**

866.652.2100

Item	Qty.	Description
29	1	37" h Vertical Extrusion
30	1	37" h Vertical Extrusion w/ Door Stopper
31	1	37" h Vertical Extrusion w/ Hinges
32	1	38" h Vertical Extrusion
33	4	11.8094" w Horizontal Extrusion
34	2	12.1599" w Curved Horizontal Extrusion
35	2	18.0687" w Curved Horizontal Extrusion
36	1	Round Base Plate
37	1	36.75" Vertical Extrusion

Steps:

- 1) Attach lower horizontal extrusions [33, 34, and 35] between vertical extrusions [29, 30, 31, and 32].
- 2) Place inserts and door between vertical extrusions as shown.
- 3) Attach upper horizontal extrusions [33, 34, and 35] between vertical extrusions [29, 30, 31, and 32] and atop inserts and door.
- 4) Attach base plate [36] to vertical support [37].
- 5) Velcro shelf supports to inside of assembled base.
- 6) Place internal shelf atop supports.
- 7) Set counter top on assembled pedestal as shown.

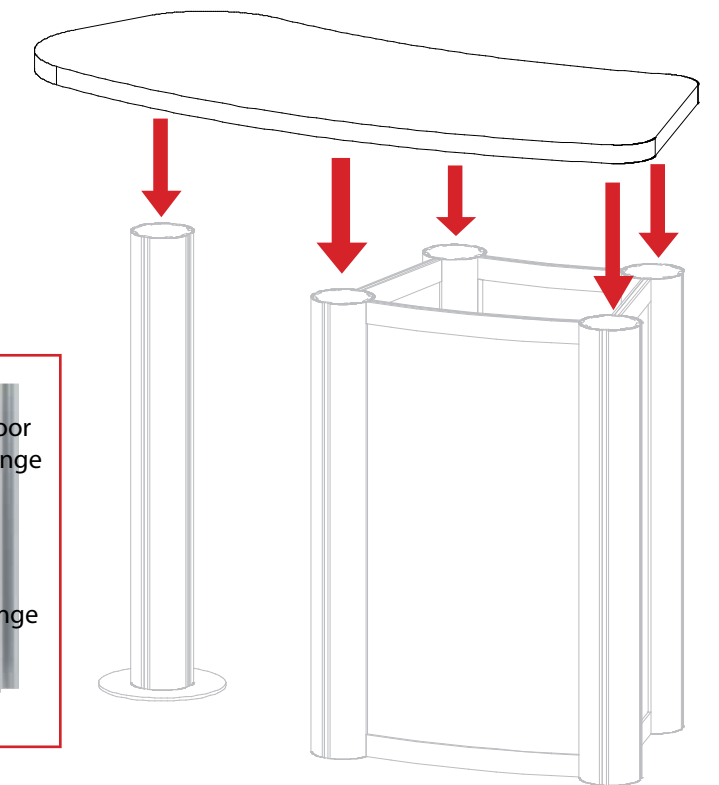
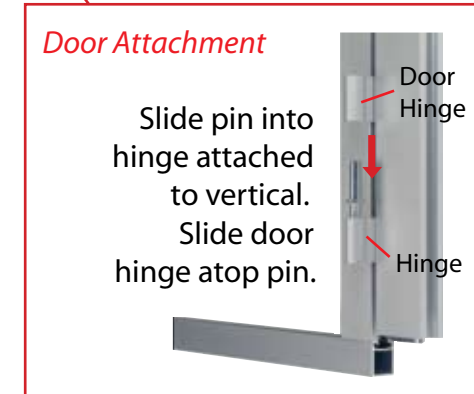
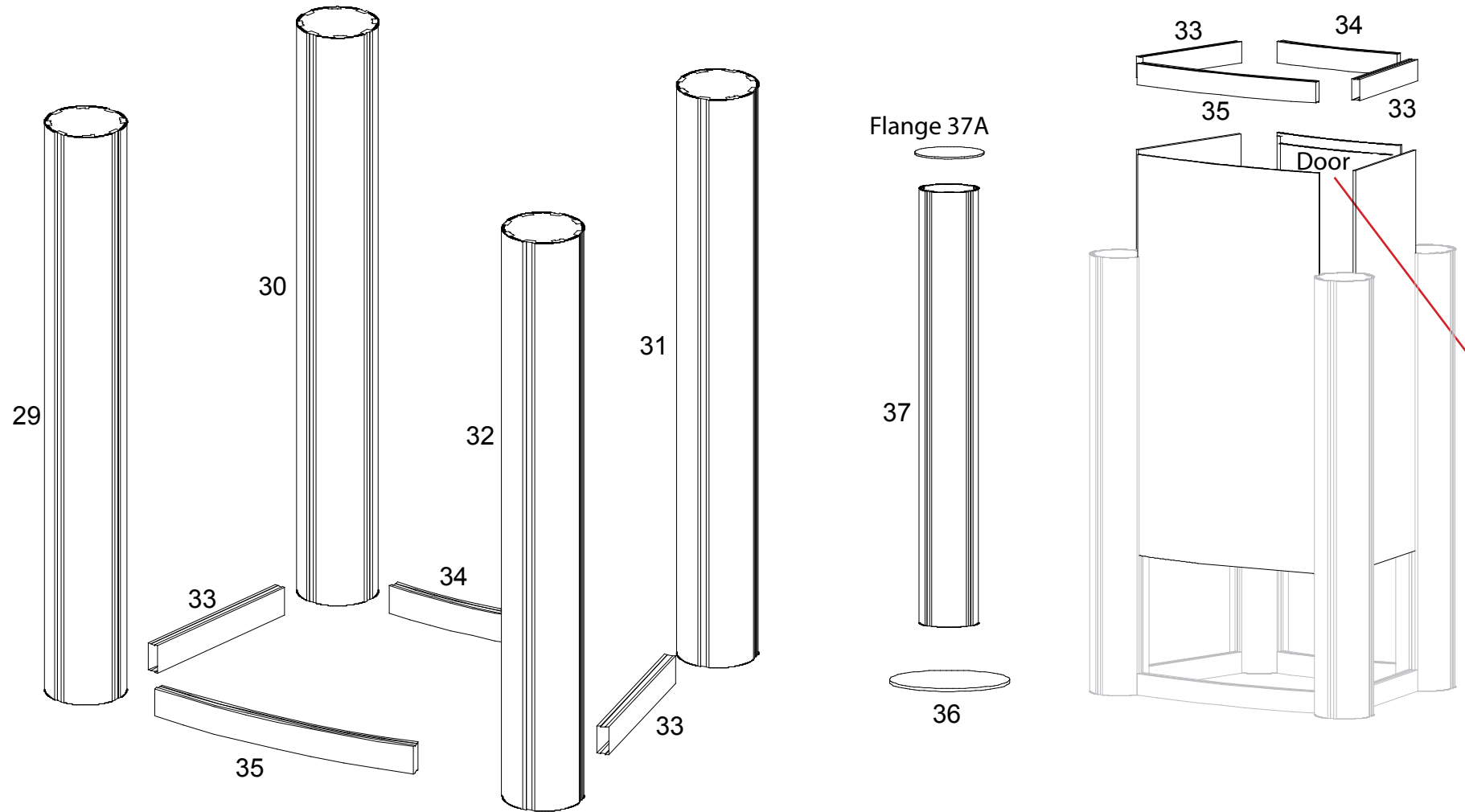
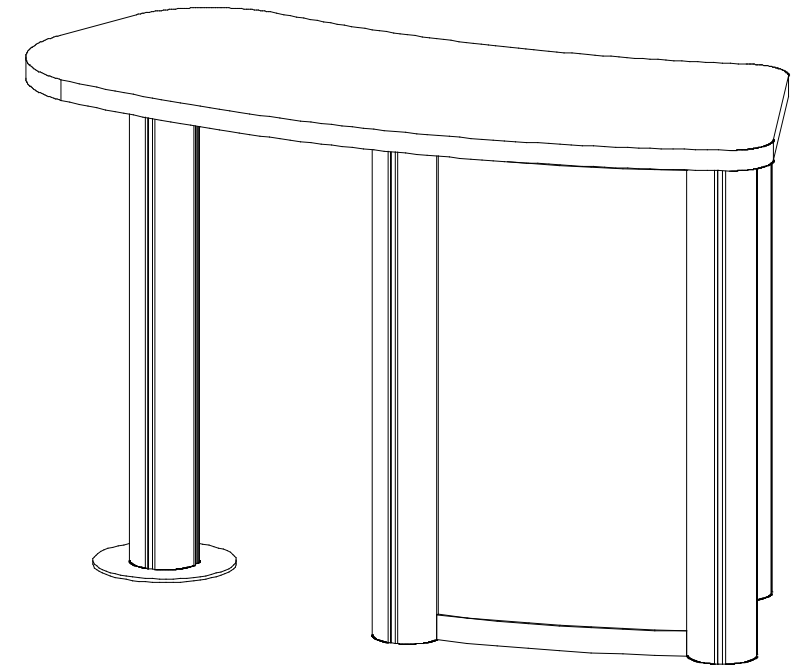

**WHEN DISASSEMBLING ALUMINUM EXTRUSION, TIGHTEN ALL SETSCREWS AND LOCKS TO PREVENT LOSS DURING SHIPPING**

Case 1

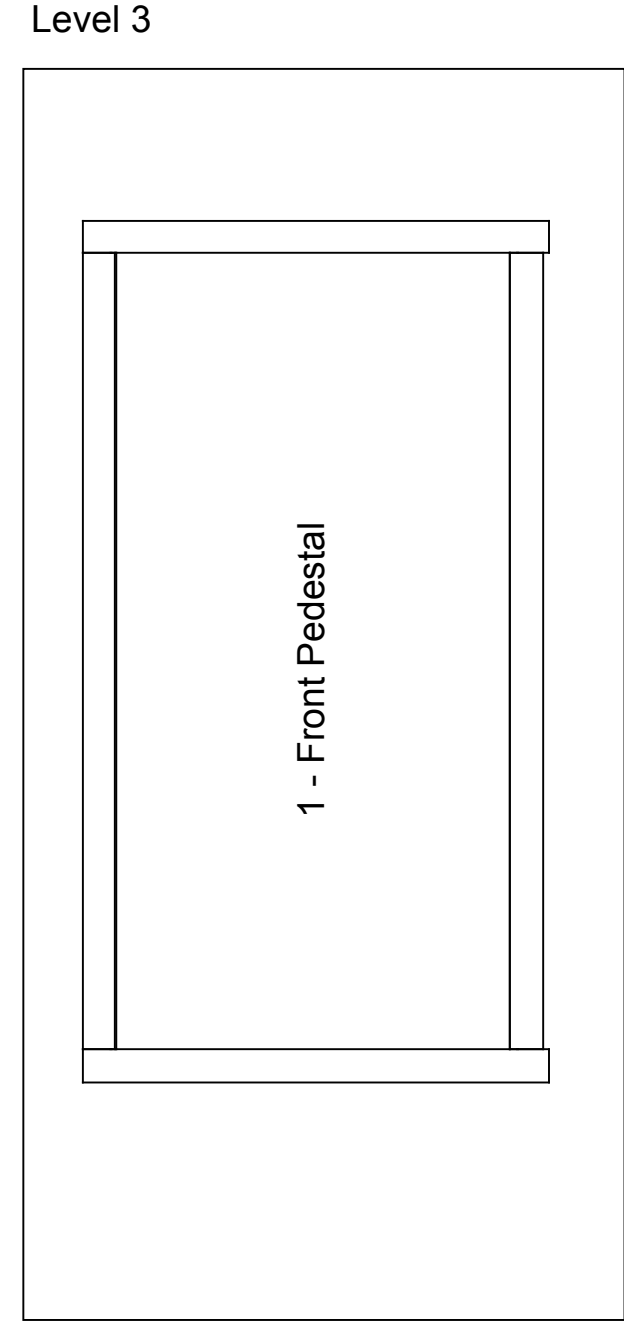
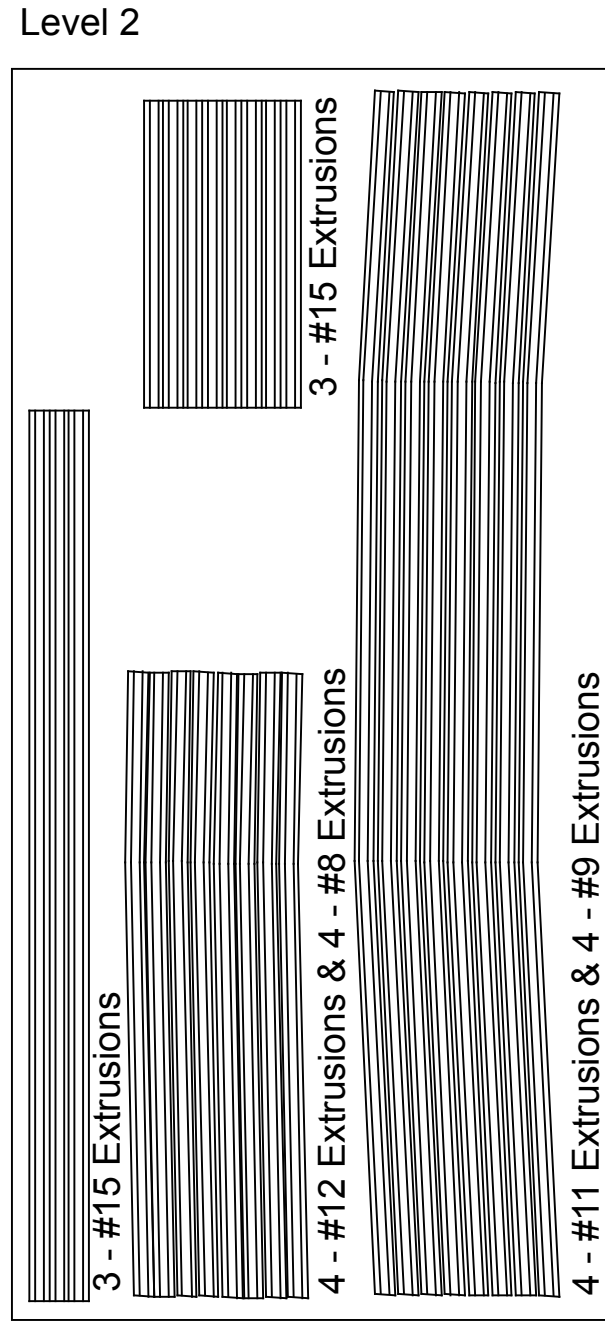
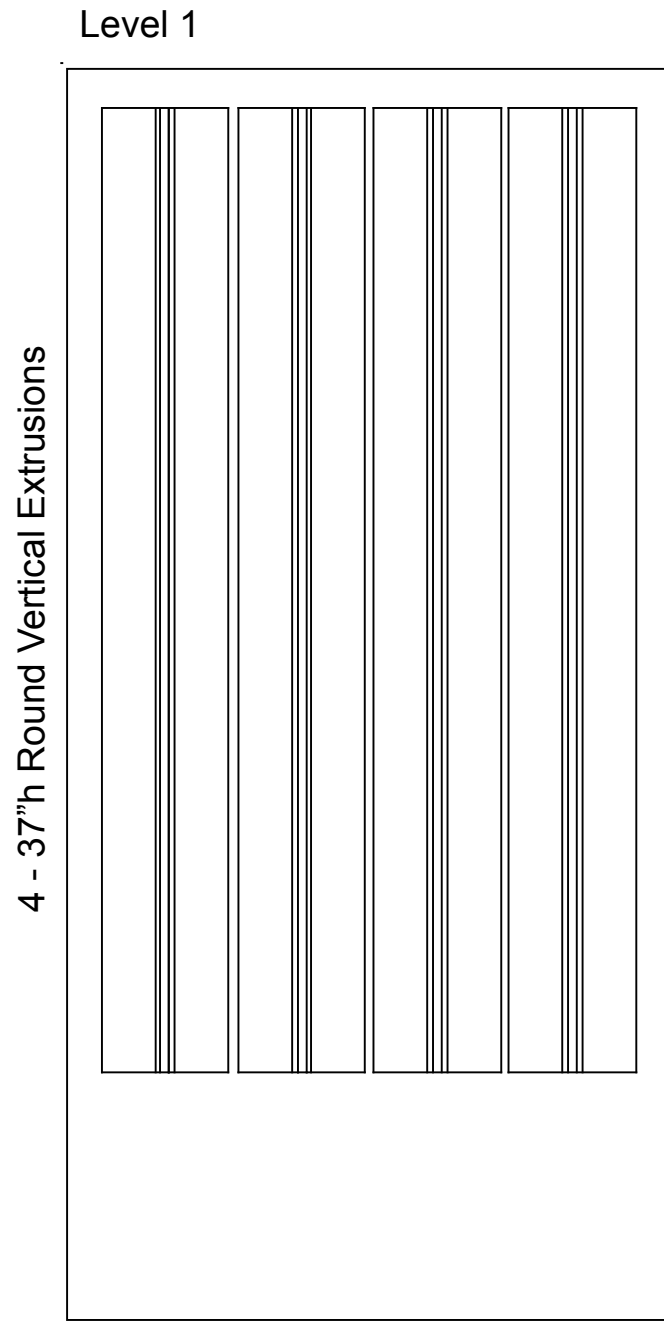

WHEN DISASSEMBLING ALUMINUM EXTRUSION, TIGHTEN ALL SETSCREWS AND LOCKS TO PREVENT LOSS DURING SHIPPING

Case 2

Level 1

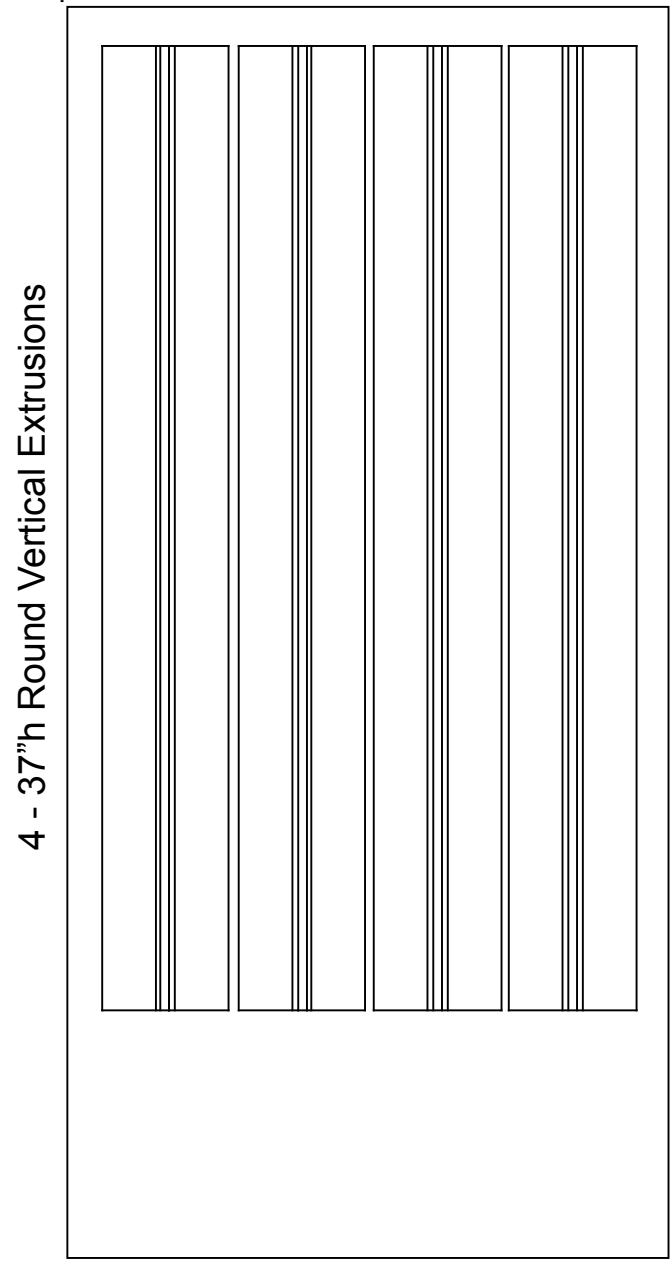

Level 2

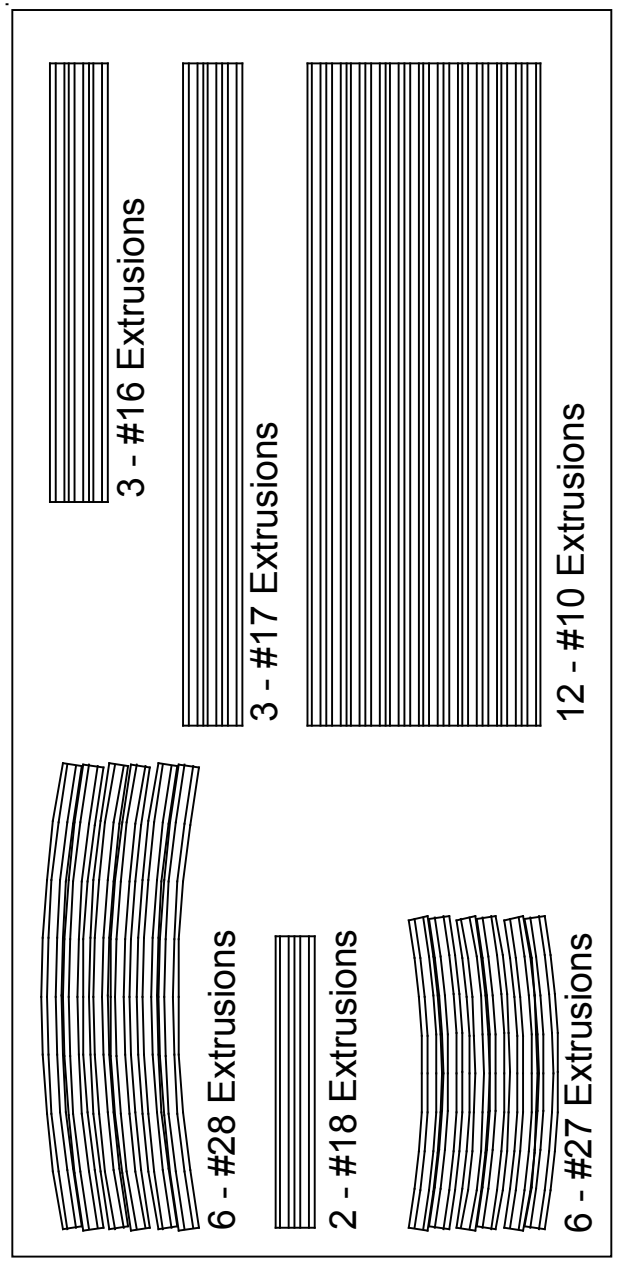

Level 3

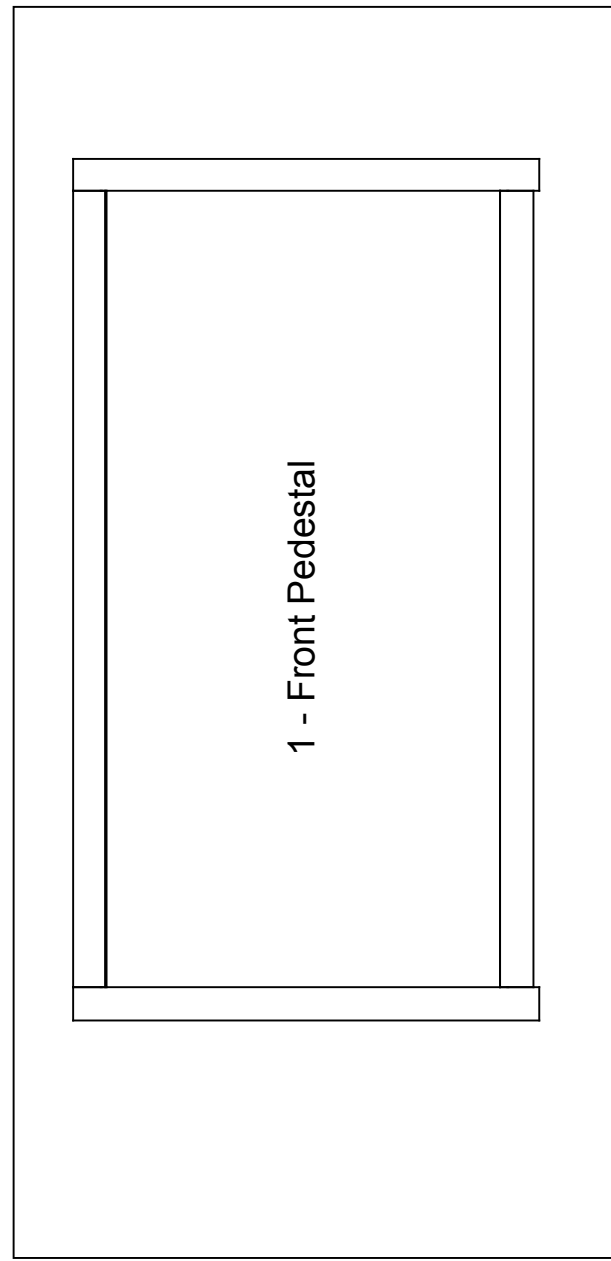

WHEN DISASSEMBLING ALUMINUM EXTRUSION, TIGHTEN ALL SETSCREWS AND LOCKS TO PREVENT LOSS DURING SHIPPING

Case 3

Level 1

4 - 37" h Round Vertical Extrusions

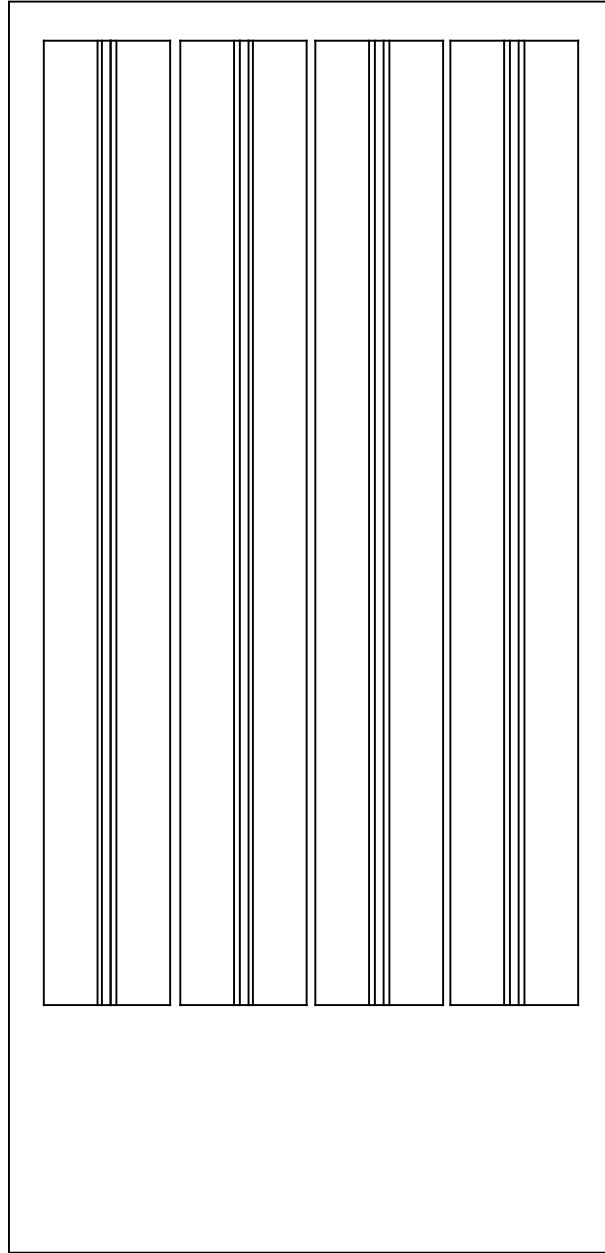

Level 2

4 - #14 Extrusions  
4 - #13 Extrusions

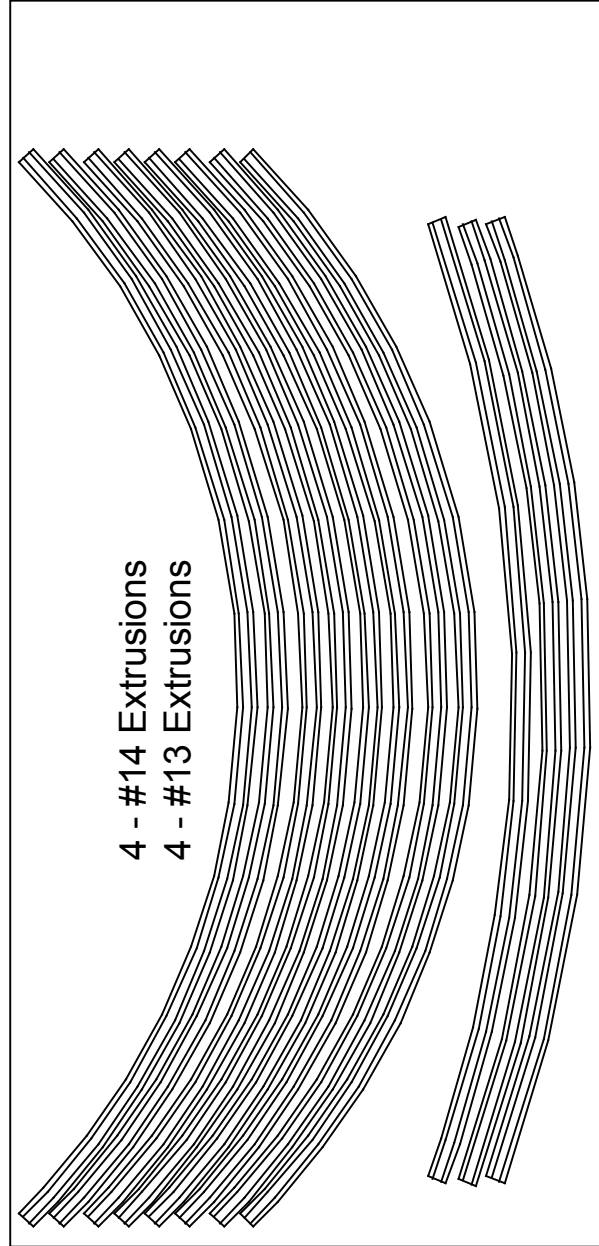

3 - piece Header Extrusion

Level 3

1 - Back Pedestal Door

1 - Back Pedestal Door

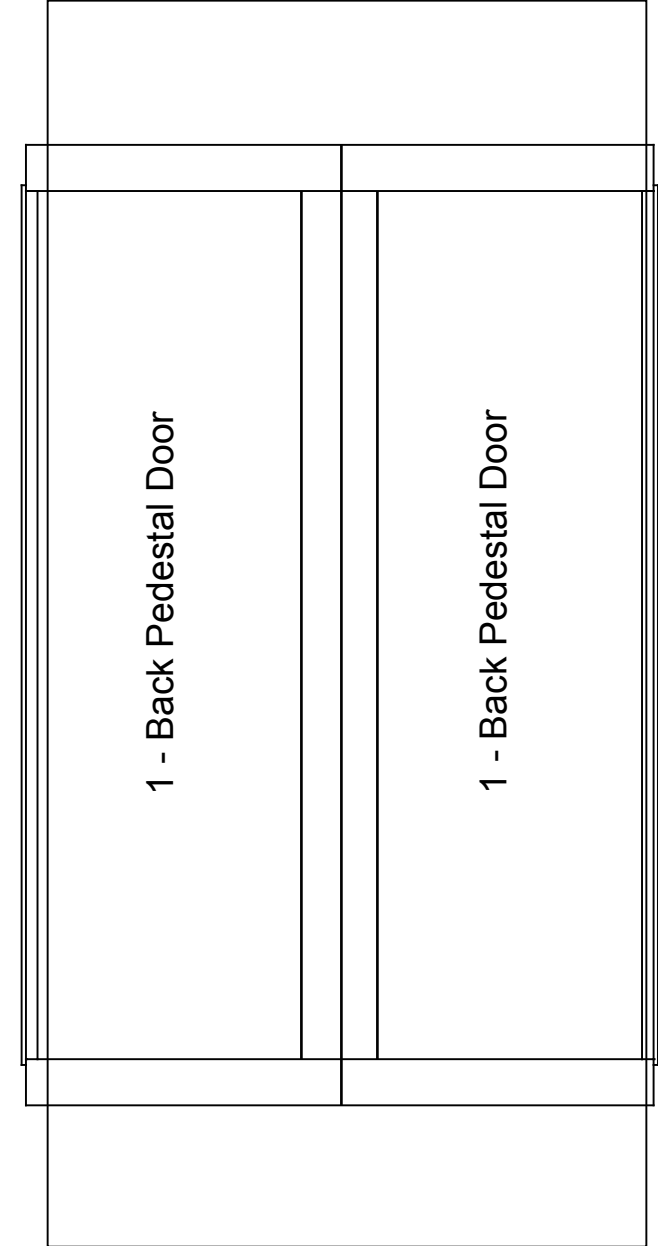

WHEN DISASSEMBLING ALUMINUM EXTRUSION, TIGHTEN ALL SETSCREWS AND LOCKS TO PREVENT LOSS DURING SHIPPING

Case 4

Level 1

4 - 37" h Round Vertical Extrusions

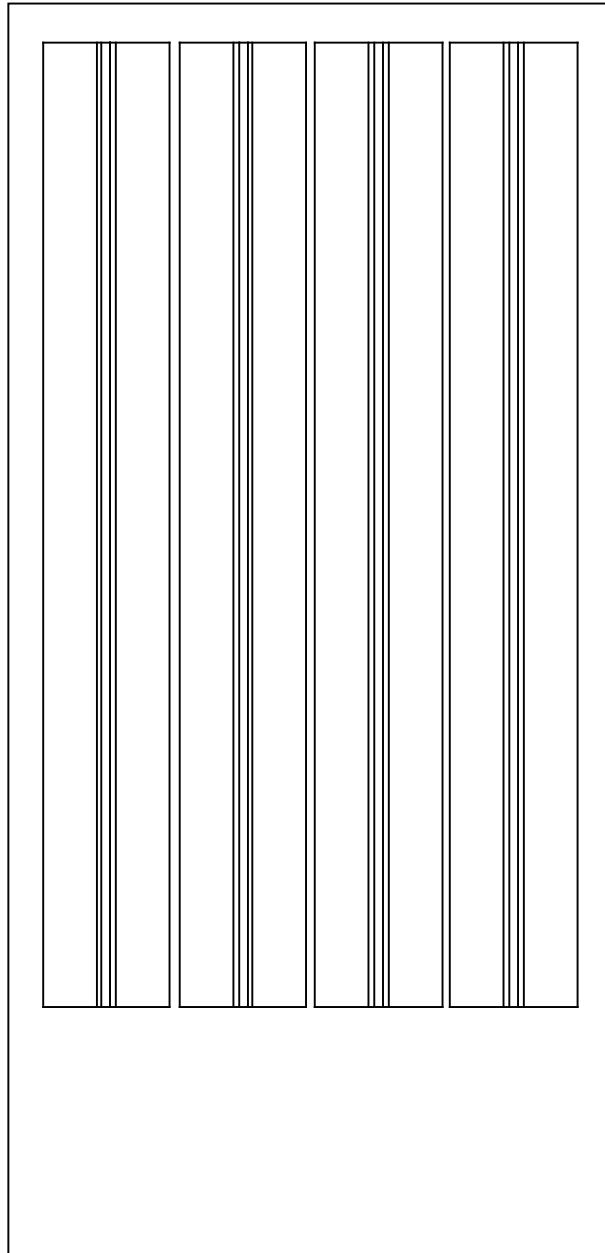

Level 2

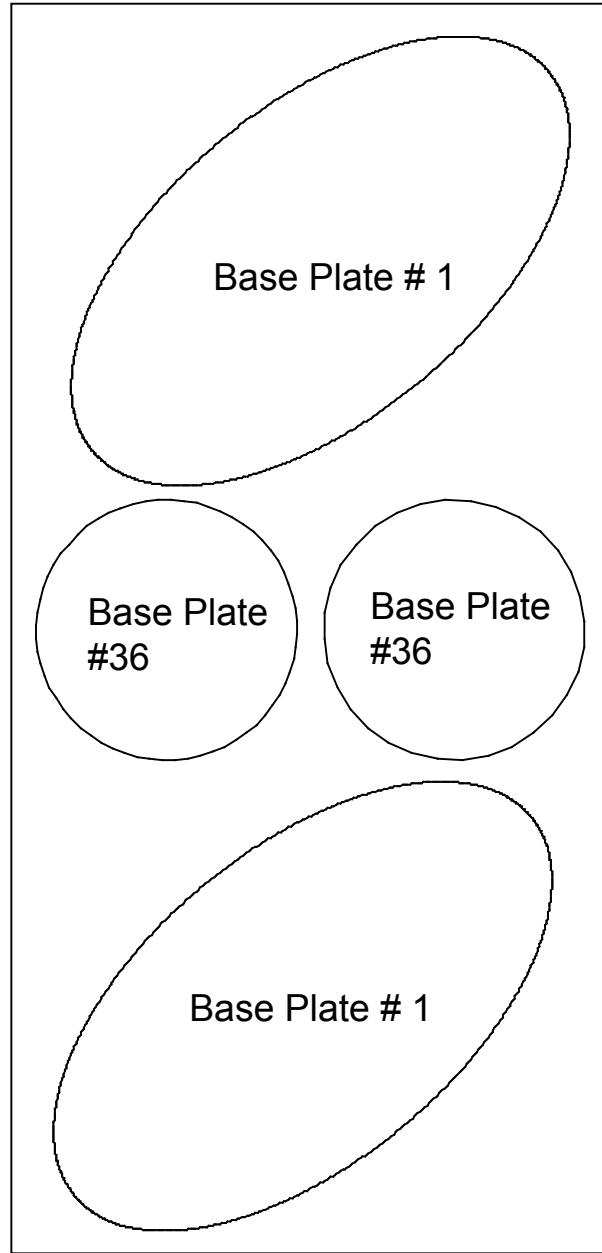

Level 3

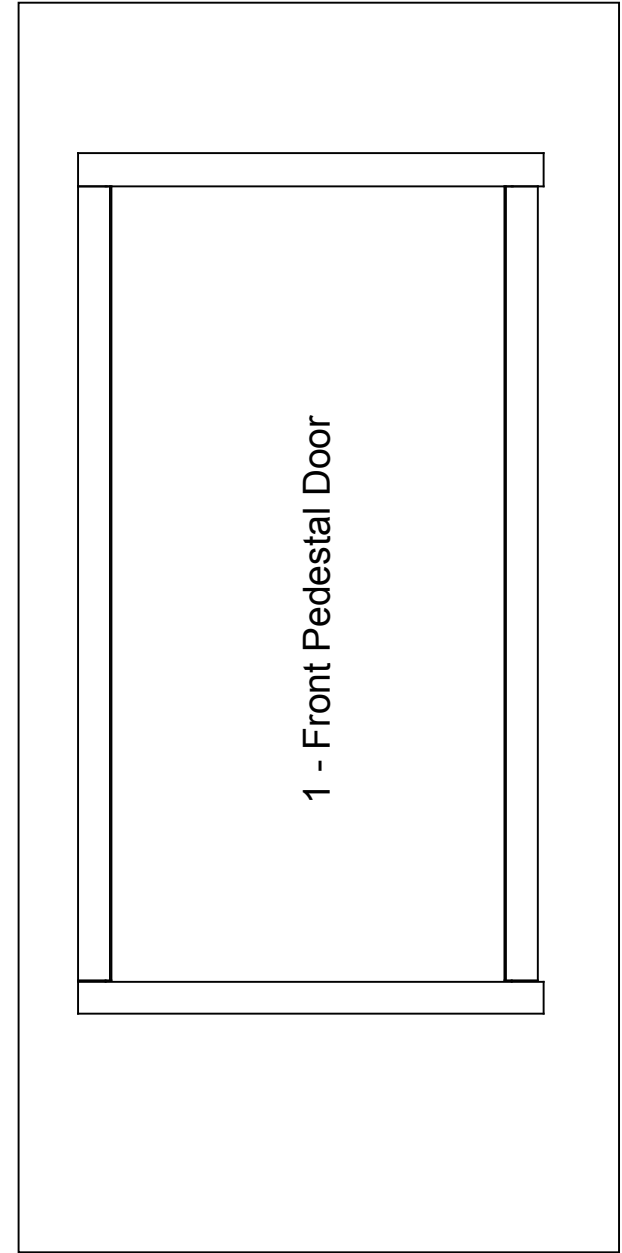

WHEN DISASSEMBLING ALUMINUM EXTRUSION, TIGHTEN ALL SETSCREWS AND LOCKS TO PREVENT LOSS DURING SHIPPING

Case 5

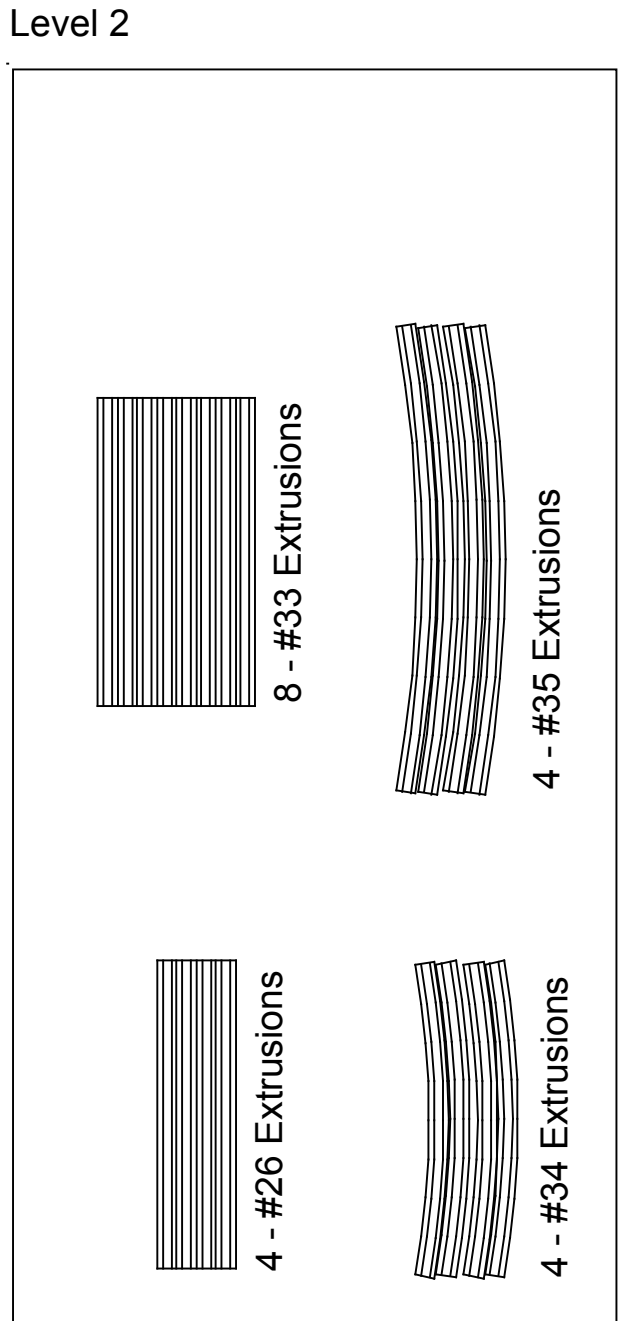
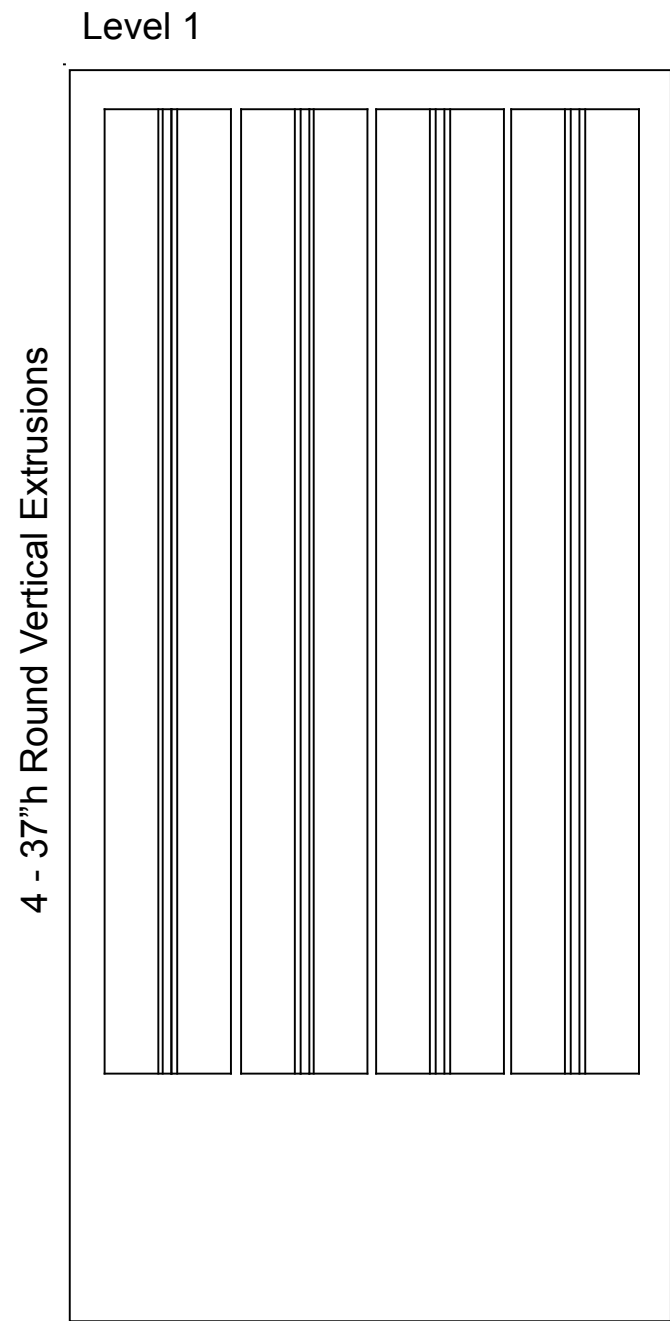

WHEN DISASSEMBLING ALUMINUM EXTRUSION, TIGHTEN ALL SETSCREWS AND LOCKS TO PREVENT LOSS DURING SHIPPING

Case 6

Level 1

4 - 48" Square Vertical Extrusions

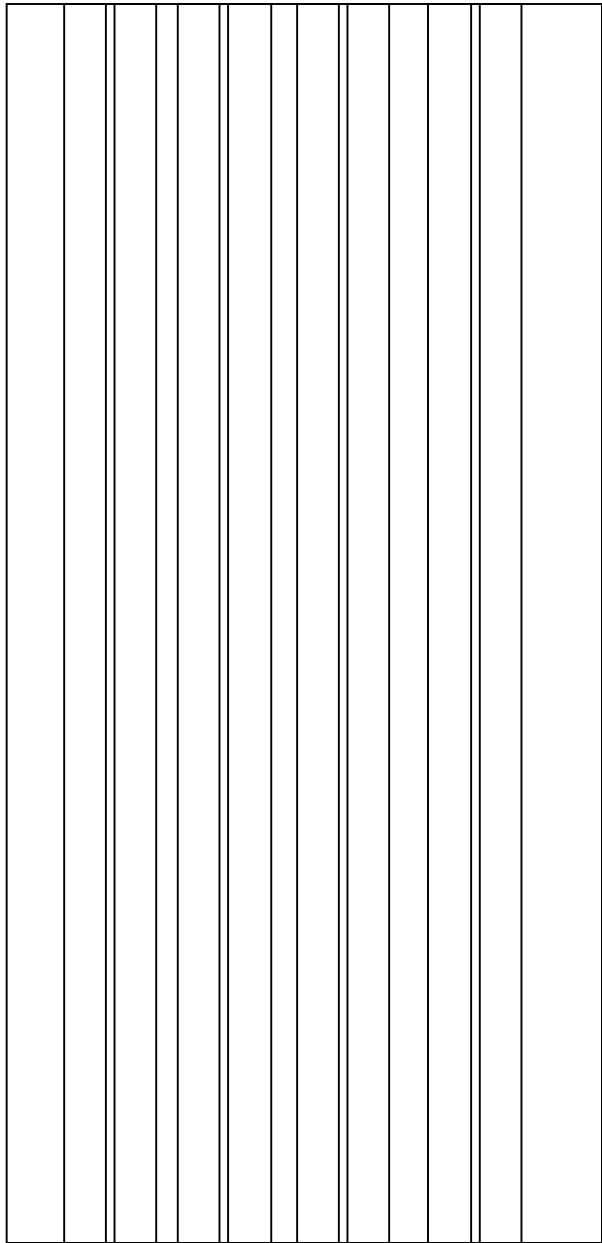

Level 2

All Pedestal Inserts

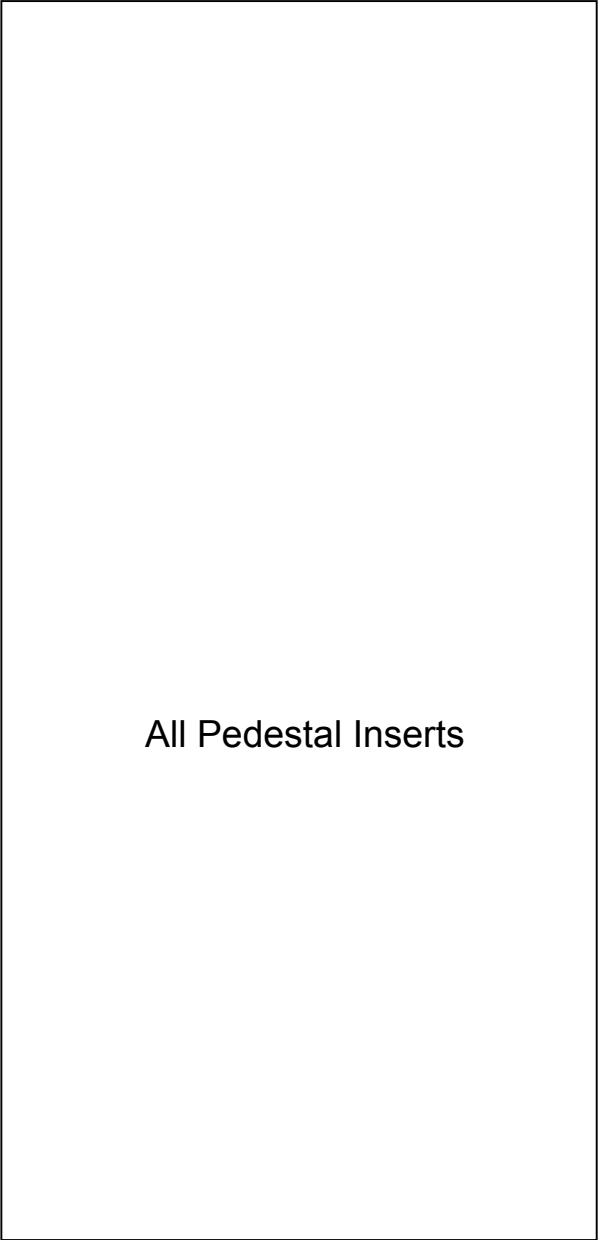

WHEN DISASSEMBLING ALUMINUM EXTRUSION, TIGHTEN ALL SETSCREWS AND LOCKS TO PREVENT LOSS DURING SHIPPING

Case 7

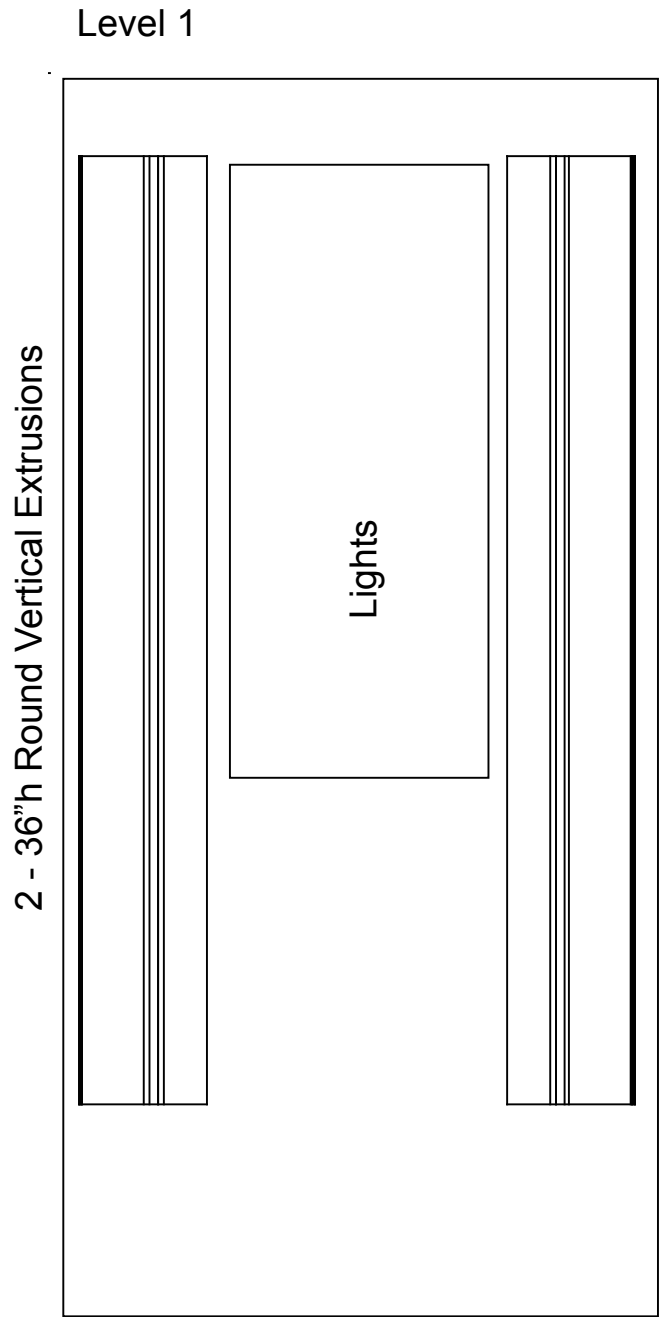

WHEN DISASSEMBLING ALUMINUM EXTRUSION, TIGHTEN ALL SETSCREWS AND LOCKS TO PREVENT LOSS DURING SHIPPING

Case 8

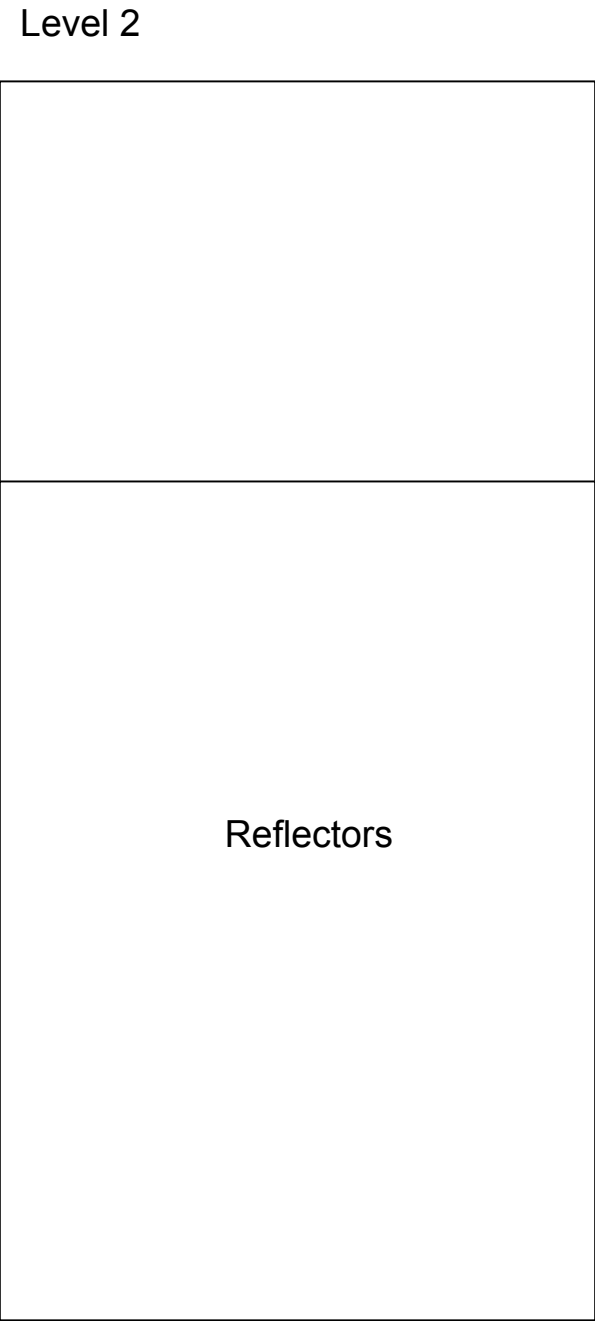
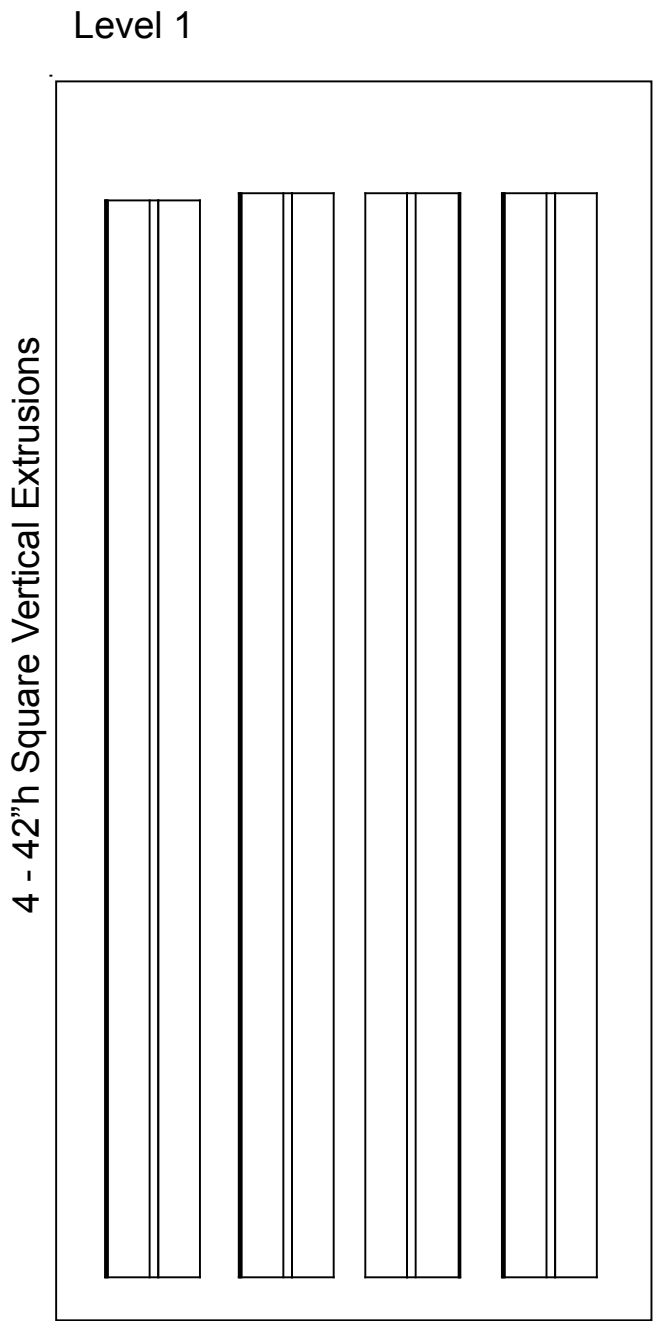

WHEN DISASSEMBLING ALUMINUM EXTRUSION, TIGHTEN ALL SETSCREWS AND LOCKS TO PREVENT LOSS DURING SHIPPING

Case 9

Level 1

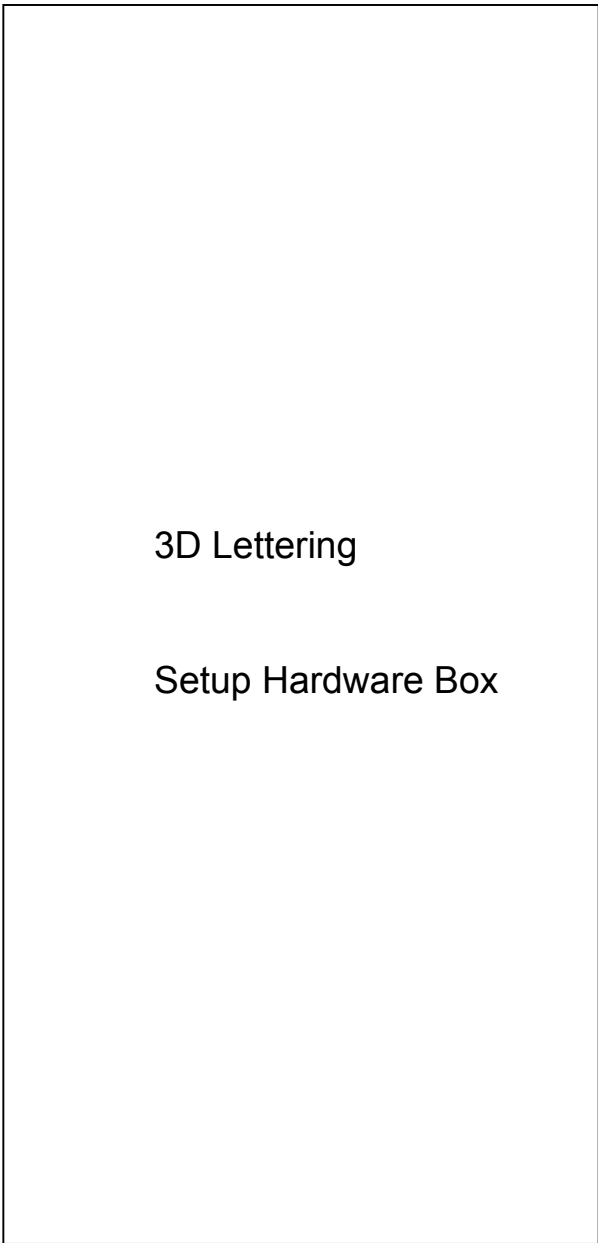

3D Lettering

Setup Hardware Box

WHEN DISASSEMBLING ALUMINUM EXTRUSION, TIGHTEN ALL SETSCREWS AND LOCKS TO PREVENT LOSS DURING SHIPPING