

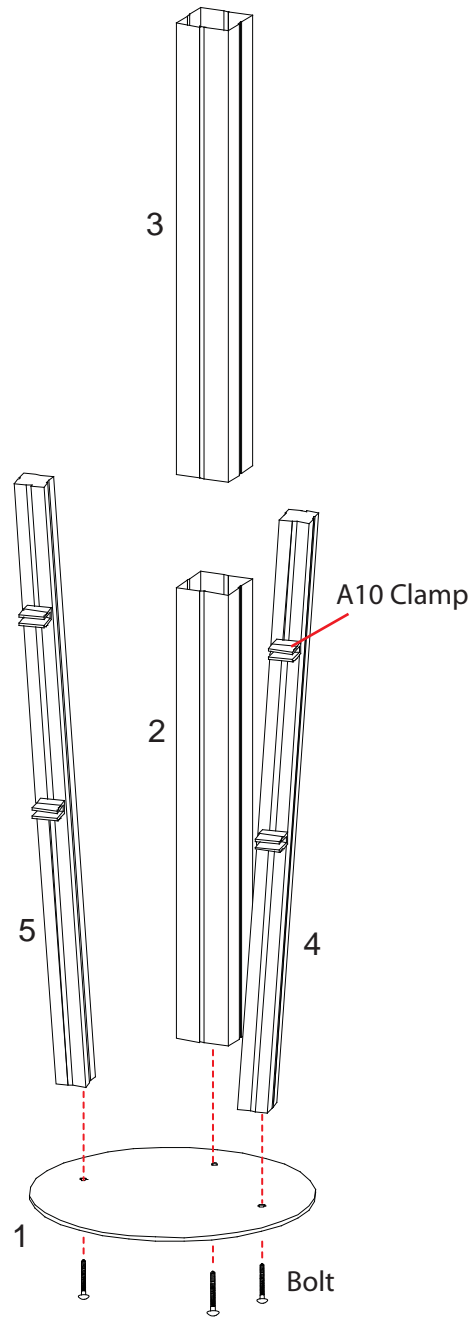

Item	Qty.	Description
1	1	Base Plate
2	1	30" h Lower Vertical Extrusion
3	1	30" h Upper Vertical Extrusion
4	1	37.461" h Right Vertical Extrusion
5	1	37.461" h Left Vertical Extrusion
6	1	15.674" w Horizontal Extrusion

Steps:

- 1) Attach vertical extrusions [2, 4 and 5] to base plate [1], see detail D on General Info page for base plate attachment.
- 2) Connect upper vertical extrusion to lower vertical extrusion [3 to 2].
- 3) Slide insert between vertical extrusions [4 and 5], then attach horizontal extrusion [6] between vertical extrusions [4 and 5] atop insert.
- 4) Attach shelves in place.
- 5) Set counter atop assembled base and secure to vertical extrusion [3] using thumbscrews.
- 6) Attach literature racks to assembled kiosk, see Literature Rack Attachment detail.
- 7) Attach monitor mount to vertical extrusion [3], see Monitor Mount Attachment detail.



**Note:** A10 Clamps should remain attached to verticals as shown.

**A10 Clamp Attachment**

Rotate Clamp to Desired Angle

Slide connector on back of A10 clamp into groove of extrusion.

When desired location is found, tighten set screw to secure.

Tighten black plastic set screw to secure shelf in place.

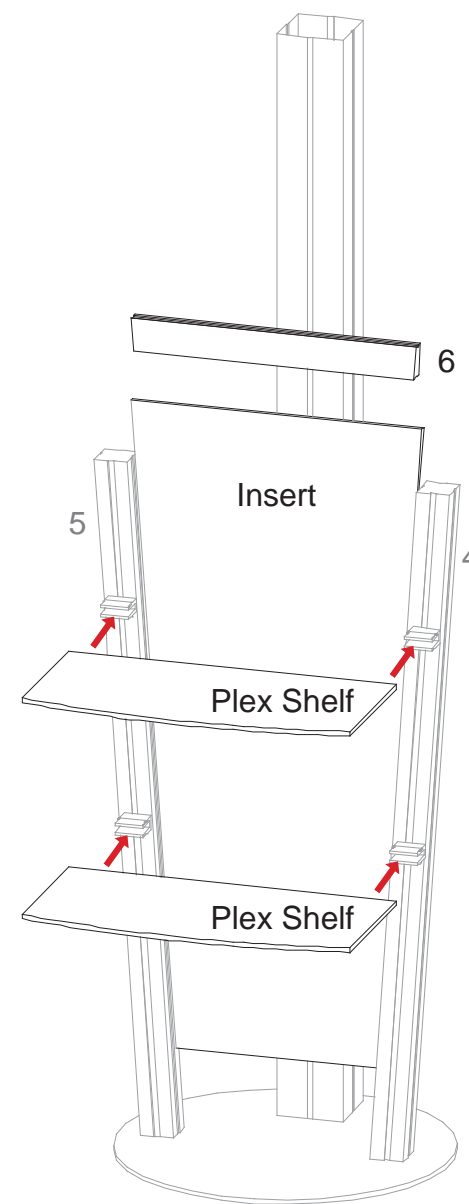

**Monitor Mount Attachment**

Attach monitor mount to vertical extrusions after assembly.

Slide Mount into Groove of Vertical Extrusion. Tighten Setscrew. Attach top Plate and tighten screws.

**Literature Rack Attachment**

Tighten Lock to Secure

Attach connector piece to rack as shown. Then connect assembled literature rack to vertical extrusion.

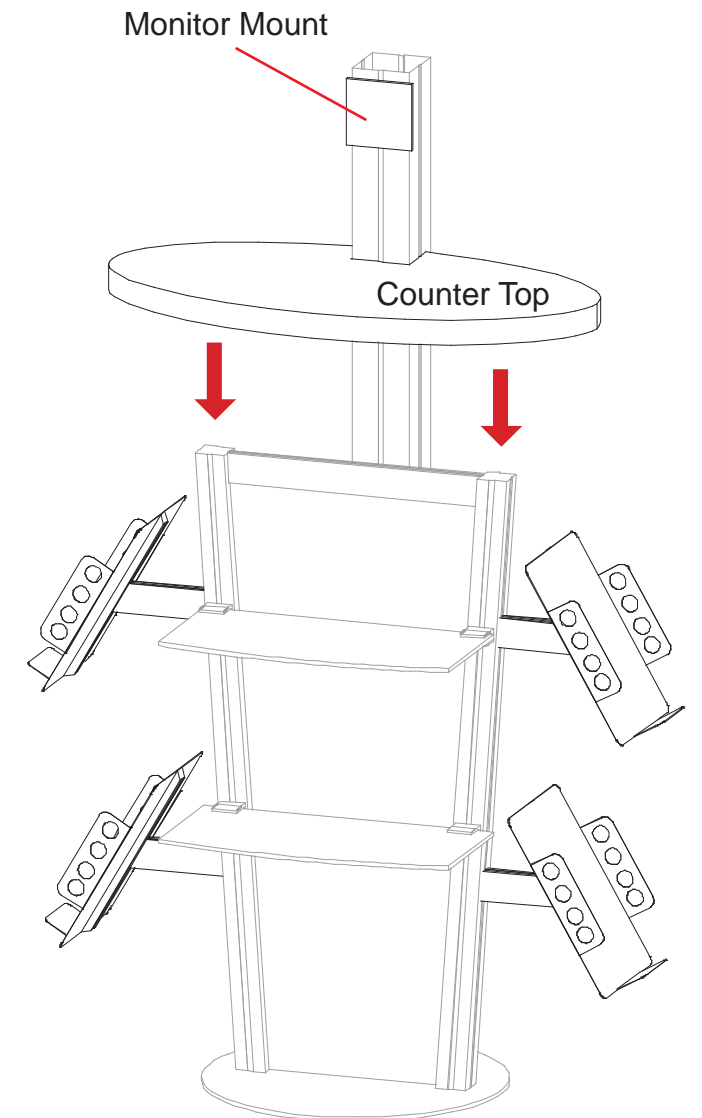

**WHEN DISASSEMBLING ALUMINUM EXTRUSION, TIGHTEN ALL SETSCREWS AND LOCKS TO PREVENT LOSS DURING SHIPPING**

# visionary™ IDESIGNS

## Using Your Setup Instructions

The Visionary Designs Setup Instructions are created specifically for your configuration. They are laid out sequentially, including an exploded view of the entire display, and then a logical series of detailed steps to assemble the main structure and components. We encourage you to study the instructions **before** attempting to assemble your exhibit.

Each page reminds you to tighten the setscrews after disassembling your exhibit to prevent loss of the locks and setscrews (see below in RED). This is VERY IMPORTANT.

## Cleaning and Packing Your Display

- 1) Use care when cleaning aluminum extrusion or acrylic inserts. Use only non-abrasive cleaners.
- 2) When cleaning laminate inserts or countertops, use mild cleansers and a soft material such as cotton.
- 3) Keep all display components away from extreme heat and long exposure to sunlight to avoid warping and fading.
- 4) Retain all packing material. It will make re-packing much easier and will reduce the likelihood of shipping damage.



The Tool

Most Visionary Designs exhibits can be assembled with the supplied Hex Key Tool. Occasionally, a flat head screwdriver may be required.



Typical Connection

Most horizontal extrusion connections have a patented expandable lock. This lock inserts into the groove of an opposing extrusion. Tightening the lock with the Hex Key Tool expands the lock and creates a strong positive connection.



Typical Connection (cont'd)

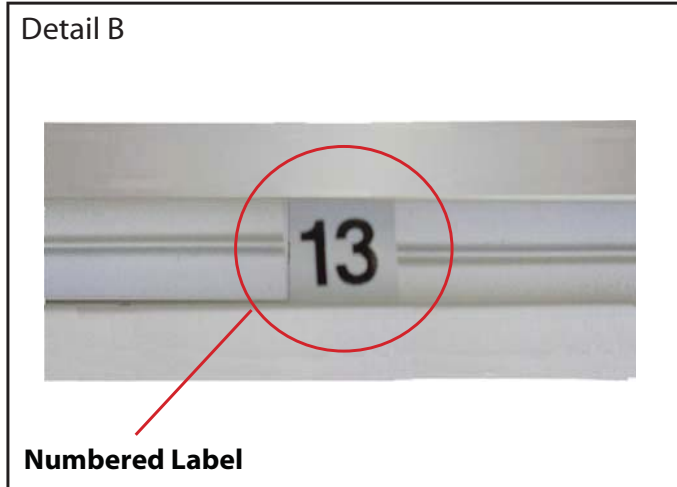

Numbered Label

Each extrusion contains a numbered label which corresponds with setup instructions. The label is located within a groove of the extrusion (when possible). With Visionary Designs the labels contain Black numbers unless otherwise specified.



Horizontal Inline Connection (remove only one setscrew)

Remove only (1) setscrew when disassembling. Replace setscrew in extrusion after assembling it. Before packing, replace setscrew in extrusion to avoid losing it.

**NOTE :**

PDF copies of your Setup Instructions are available @ [www.classicexhibits.com](http://www.classicexhibits.com)  
Use the Search Tool located on the lower left-hand corner of the Classic Home page.

Enter your 5-7 digit Order #.  Search for Setup Instructions

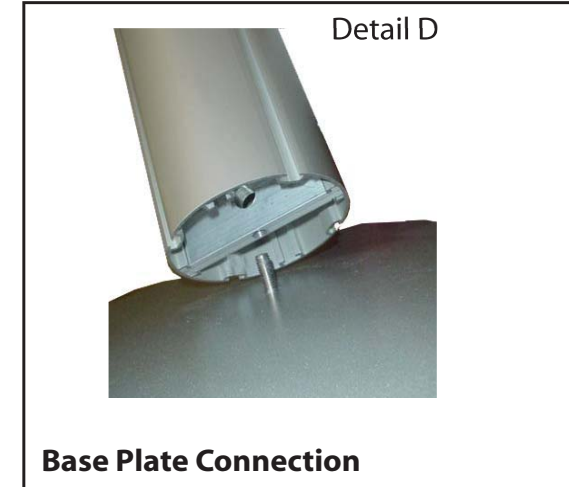

Base Plate Connection

Attach base plate to round or square vertical extrusion using the bolt provided. Be careful not to strip the threads.

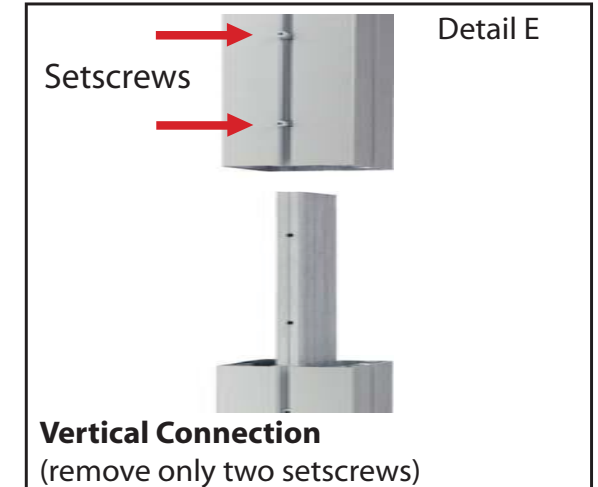

Vertical Connection (remove only two setscrews)

When vertical extrusions are packed in portable cases rather than crates or tubs, they must be broken down into smaller sections which then require assembly.

Remove only (2) setscrews when disassembling. Replace setscrews in extrusion after assembling it. Before packing, replace setscrews in extrusion to avoid losing them.

**WHEN DISASSEMBLING ALUMINUM EXTRUSION, TIGHTEN ALL SETSCREWS AND LOCKS TO PREVENT LOSS DURING SHIPPING**